

Domal Slide C160 ST
Scorrevoli



CONSIGLI PRATICI PER:

- LAVORAZIONE
- PROTEZIONE
- PULIZIA
- MANUTENZIONE

DELL' ALLUMINIO VERNICIATO ED OSSIDATO

1. **IMBALLAGGIO.** Impiegare la giusta protezione, evitando di esporre il profilo protetto direttamente ai raggi solari. In ogni caso il prodotto impiegato per eventuali reimpballi deve essere compatibile con la verniciatura o con l'ossidazione ed occorre seguire le istruzioni del fornitore.
2. **LAVORAZIONE.** Durante tutte le fasi di lavorazione manovrare i profilati con estrema delicatezza ed accertarsi che l'ambiente di lavoro sia pulito. Usare la massima cura nella movimentazione dei pezzi. Evitare il contatto con scorie o residui di limature delle lavorazioni precedenti.
3. **ATTREZZATURE.** Accertarsi che i macchinari e gli utensili siano sempre efficienti ed adatti al compito da svolgere, in particolare le lame e le troncatrici. Per il raffreddamento degli utensili evitare prodotti che possono intaccare la colorazione dei profilati e pregiudicarne la qualità.
4. **SIGILLATURA.** Sigillare accuratamente con prodotti idonei tutti i tagli e/o fori di lavorazione del serramento, bloccando ogni zona soggetta ad infiltrazione. Accertarsi sempre che ci sia un corretto drenaggio all'interno dello scatolato del serramento.
5. **ACCESSORI.** Utilizzare esclusivamente accessoristica di ottima qualità. La viteria deve sempre essere in materiale adatto e, possibilmente, isolato. Ricordare sempre che tutto ciò che non è alluminio, ma è in contatto con quest'ultimo, può creare problemi di corrosione. Evitare l'uso delle squadrette in ferro non opportunamente trattate.
6. **LUBRIFICANTI.** Eseguire con particolare attenzione ed appositi olii la lubrificazione dell'accessoristica.
7. **POSA IN OPERA.** La buona norma richiede sempre di installare per ultimo il serramento in alluminio, evitando in questo modo possibili inconvenienti dovuti al contatto con sostanze presenti in cantiere che possono danneggiare le superfici verniciate o anodizzate.
8. **MANUTENZIONE E PULIZIA.** Per mantenere il più possibile inalterate nel tempo le superfici anodizzate o verniciate, è necessario che le stesse vengano opportunamente pulite con prodotti appositi.

In ogni caso si raccomanda vivamente di:

- Pulire le superfici quando non sono esposte a fonti di calore diretto, ad esempio i raggi solari.
- Usare per la pulizia una spugna o un panno bagnato con l'apposito detergente.
- Il detergente deve essere: neutro, non abrasivo, non a base di ammoniaca, non a base di cloro (ad esempio candeggina).
- Le parti meccaniche debbono essere: pulite ed oliate tramite spray al silicone oppure al teflon e controllate anche a livello di usura.

La Sapa Building Systems S.P.A. fornisce prodotti con finiture garantite dai marchi QUALANOD e QUALICOAT

CONTENUTO

Prima pagina.....	0	Accessori - Varie.....	E.4.3
Contenuto.....	1	Accessori - Accessori di sistema.....	E.4.4
Indice.....	5	Viti.....	E.5.1

A INFORMAZIONI SISTEMA

1-binario o.....	A.1.1
1-binario - Soglia ribassata.....	A.2.1
2-binari.....	A.3.1
3-binari.....	A.4.1
Tagli 90°.....	A.5.1
Opzioni termiche.....	A.6.1
Direttive generali.....	A.7.1
Risultati dei test.....	A.8.1

B PROFILATI SISTEMA

Lista dei simboli.....	B.0.1
Lista profilati.....	B.1.1
Telaio.....	B.2.1
Anta.....	B.3.1
Rinforzo.....	B.4.1
Profilati cartelline.....	B.5.1
Profilati gocciolatoi.....	B.6.1
Profilati guida.....	B.7.1
Profilati complementari.....	B.8.1
Binari addizionali.....	B.9.1
Momento di inerzia.....	B.10.1

C PROFILATI VARI

Finestre - Profilati di finitura.....	C.2.1
---------------------------------------	-------

D VETRATURA

Tabella vetratura.....	D.1.1
Vetratura con RU0004.....	D.1.1
Vetratura con RU0002.....	D.1.2
Fermavetro.....	D.2.1
Accessori.....	D.2.2

E ACCESSORI

squadrette - Squadrette con spine coniche.....	E.1.1
Squadrette - Squadrette a cianfrinare.....	E.1.2
Squadrette - Squadrette con eccentrico.....	E.1.3
Squadrette - Cavallotti.....	E.1.4
Squadrette - Accessori per squadrette.....	E.2.1
Squadrette - Squadrette di allineamento.....	E.2.2
Guarnizioni - Finestre.....	E.3.1
Guarnizioni - Varie.....	E.3.3
Guarnizioni - Guarnizioni di sistema.....	E.3.4
Accessori - Finestre.....	E.4.1

F SELEZIONE FERRAMENTA

Panoramica.....	F.1.1
Alzante-scorrevole.....	F.1.2
Maniglie standard.....	F.1.2
Maniglie S-Line (Harmony).....	F.1.3
Hv = 1303 - 1903.....	F.1.4
Hv = 1904 - 2803.....	F.1.5
Hv = 2804 - 3403.....	F.1.6
Alzante-scorrevole - Schema 4 ante.....	F.1.7
Pezzi supplementari.....	F.1.7
Lista articoli ferramenta.....	F.2.1

G ATTREZZATURE

Lavorazione - D5110000.....	G.1.1
Dime lavorazioni - Panoramica.....	G.2.1
Dime lavorazioni - TG4116.....	G.2.2
Dime lavorazioni - TG4119.....	G.2.6

H NODI

Nodi - Panoramica.....	H.0.1
Nodi.....	H.1.1
1-binario (C9K010) - Alzante-scorrevole - Superiore sinistro.....	H.1.1
1-binario (C9K010) - Alzante-scorrevole - Inferiore sinistro.....	H.1.1
1-binario (C9K010) - Alzante-scorrevole - Superiore destro.....	H.1.2
1-binario (C9K010) - Alzante-scorrevole - Inferiore destro.....	H.1.2
1-binario (C9K010) - Alzante-scorrevole - Sinistro.....	H.1.3
1-binario (C9K010) - Alzante-scorrevole - Destro.....	H.1.4
1-binario (C9K010) - Alzante-scorrevole - Centrale.....	H.1.5
1-binario soglia ribassata tagli 90° - Alzante-scorrevole - Superiore sinistro.....	H.1.6
1-binario soglia ribassata tagli 90° - Alzante-scorrevole - Inferiore sinistro.....	H.1.6
1-binario soglia ribassata tagli 90° - Alzante-scorrevole - Superiore destro.....	H.1.7
1-binario soglia ribassata tagli 90° - Alzante-scorrevole - Inferiore destro.....	H.1.7
1-binario soglia ribassata tagli 90° - Alzante-scorrevole - Sinistro.....	H.1.8
1-binario soglia ribassata tagli 90° - Alzante-scorrevole - Destro.....	H.1.8
1-binario soglia ribassata tagli 90° - Alzante-scorrevole - Centrale.....	H.1.9
1-binario soglia ribassata tagli 90° - Alzante-scorrevole - Centrale.....	H.1.10
1-binario soglia ribassata tagli 90° - Alzante-scorrevole - Centrale.....	H.1.11
Rinforzo interno - 1 anta.....	H.1.13
Rinforzo interno - 2 ante.....	H.1.14

I DISTINTE DI TAGLIO

J FERRAMENTA & DISEGNI

ASSEMBLAGGIO

Direttive generali.....	J.1.1
Assemblaggio generale - e specifiche di montaggio in officina ...	J.1.1
Drenaggio "lato bagnato".....	J.1.4
1-binario (C9K010) telaio.....	J.2.1
Contenuto.....	J.2.3
Taglio del C9K010 e installazione BT6000.....	J.2.4
Lavorazione del C9K010 per inserimento squadrette.....	J.2.5
C9K010 panoramica drenaggi.....	J.2.6
C9K010 lavorazione drenaggio - J.....	J.2.7
C9K010 lavorazione drenaggio - H.....	J.2.8
C9K010 lavorazione drenaggio - B.....	J.2.9
C9K010 lavorazione drenaggio - A.....	J.2.10
C9K010 lavorazione drenaggio - G.....	J.2.11
C9K010 lavorazione drenaggio - F.....	J.2.12
Installazione VS0107.....	J.2.14
Tappo tenuta centrale CO1116 sul profilato inferiore, alzante-scorrevole.....	J.2.15
Sigillatura profilato inferiore con tappi VS9951, VS9958 e VS9959.....	J.2.16
Lavorazione del C9K010 per cavallotti su montante.....	J.2.17
Lavorazione del C9K010 per cavallotti su montante - schema 4 ante.....	J.2.18
Tappo tenuta centrale CO1114 sul profilato superiore, alzante-scorrevole.....	J.2.19
Installazione punti di chiusura -alzante-scorrevole (ZB0034/ZB0035/ZB0036).....	J.2.20
Installazione cavallotti TS3M03 e TS3M04.....	J.2.21
Installazione e sigillatura montante interno.....	J.2.22
Installazione e sigillatura montante interno - TS9Z05.....	J.2.24
Assemblaggio profilato telaio con squadrette.....	J.2.25
Assemblaggio profilato telaio con squadrette.....	J.2.26
Assemblaggio profilato telaio con squadrette.....	J.2.27
Installazione binario CO1103.....	J.2.28
Installazione binario CO1103 e ZB0038 per schema 4 ante.....	J.2.29
Installazione punti di chiusura -alzante-scorrevole.....	J.2.30
Preparazione labirinto KU2029 + RU9095 + KU6004 + RU9703 + CO2181 + VS9148.....	J.2.32
Lavorazione addizionale labirinto su montante interno.....	J.2.33
Installazione labirinto su montante interno.....	J.2.34
Installazione RU9094 e BT6013.....	J.2.35
Preparazione e installazione cartellina C9A002.....	J.2.36
1-binario telaio soglia ribassata taglio 90°.....	J.3.1
Contenuto.....	J.3.3
Taglio C9K121.....	J.3.4
Taglio C9K121 per connessione telai.....	J.3.5
Taglio del C9K120 + KU2028 e installazione BT6006.....	J.3.8
Taglio del C9K100 + KU2035 e installazione BT6017.....	J.3.9
Panoramica drenaggi.....	J.3.10
C9K100 lavorazione drenaggio - H.....	J.3.11
C9K100 lavorazione drenaggio - B2.....	J.3.12
C9K100 lavorazione drenaggio - A.....	J.3.13
C9K100 lavorazione drenaggio - A1.....	J.3.14
C9K100 lavorazione drenaggio - A2.....	J.3.15
C9K100 lavorazione drenaggio - G.....	J.3.16
KU2035 lavorazione drenaggio - B.....	J.3.17
Installazione VS0107.....	J.3.18
Sigillatura KU2035.....	J.3.19
Sigillatura centrale del C9K100 per assemblaggio con KU2035.....	J.3.20
Installazione KU2035 su C9K100.....	J.3.21
Installazione sigillatura centrale inferiore.....	J.3.22
C9A101 lavorazione drenaggio - K2.....	J.3.23
Installazione C9A101.....	J.3.24
Installazione e sigillatura.....	J.3.25
Installazione RU9131 + RU9704 + VS0107 + CO1137.....	J.3.26

Anta fissa soglia ribassata - lavorazione profilato cartellina speciale.....	J.3.27
Installazione CO1111 tappo sigillatura centrale superiore.....	J.3.28
Installazione connessioni inferiori CO0132 e VS9957 su C9K121.....	J.3.29
Installazione connessioni superiori CO0132 e VS9957 su C9K121.....	J.3.30
Installazione VS9956 e VS9970 su anta fissa laterale.....	J.3.31
Installazione VS9956 e VS9970 su anta mobile laterale.....	J.3.32
Montaggio su telaio.....	J.3.33
Blocchetti chiusura alzante-scorrevole su C9A100 (ZB0034/ZB0035/ZB0036).....	J.3.34
Sigillatura angoli con RU9704.....	J.3.35
Installazione C9A100 e 213-006 su anta mobile laterale.....	J.3.36
Installazione C9A100 e 213-006 su anta fissa laterale.....	J.3.37
Installazione KU2035 sui lati.....	J.3.38
Installazione binario CO1103.....	J.3.39
Installazione binario CO1103 e ZB0038 per schema 4 ante.....	J.3.40
Posizionamento punti di chiusura.....	J.3.41
Preparazione ante.....	J.4.1
Panoramica assemblaggio.....	J.4.1
Contenuto.....	J.4.2
Taglio profilati anta e installazione BT6000.....	J.4.3
Lavorazione profilato anta per squadrette.....	J.4.4
Lavorazione del C9V051 profilato anta effetto "bi-metal".....	J.4.6
Lavorazione drenaggio profilata anta.....	J.4.7
Panoramica lavorazione paracolpi su profilato anta.....	J.4.8
Lavorazione paracolpi su profilato anta.....	J.4.9
Lavorazione profilato anta per tappo 1/2.....	J.4.10
Lavorazione profilato anta per ferramenta alzante-scorrevole - panoramica.....	J.4.11
Lavorazione profilato anta per ferramenta alzante-scorrevole - panoramica.....	J.4.14
Lavorazione profilato anta per ferramenta alzante-scorrevole - panoramica.....	J.4.15
Lavorazione profilato anta per ferramenta alzante-scorrevole.....	J.4.17
Installazione garanizione RU0099 per alzante-scorrevole.....	J.4.21
Assemblaggio profilato anta con squadrette.....	J.4.23
Assemblaggio ferramenta anta.....	J.6.1
Ferramenta alzante-scorrevole - panoramica.....	J.6.1
Contenuto.....	J.6.2
Preparazione carrelli alzante-scorrevole.....	J.6.3
Preparazione carrelli alzante-scorrevole (300 - 400 kg) - optional.....	J.6.5
Preparazione ZB0033/ZB0034/ZB0035/ZB0036.....	J.6.12
Preparazione ZB0033/ZB0034/ZB0035/ZB0036 - maniglia interna.....	J.6.13
Assemblaggio ZB0053/ZB0054 - sollevamento servo assistito.....	J.6.14
Preparazione ZB0046.....	J.6.15
Assemblaggio ZB0035/ZB0036 con ZB0046.....	J.6.16
Installazione chiusura meccanismo alzante-scorrevole.....	J.6.17
Installazione maniglia interna standard alzante-scorrevole.....	J.6.19
Installazione maniglia interna standard e vaschetta esterna alzante-scorrevole.....	J.6.20
Installazione maniglia interna standard con mezzo cilindro alzante-scorrevole.....	J.6.21
Maniglia interna standard con mezzo cilindro e vaschetta alzante-scorrevole.....	J.6.22
Installazione maniglia interna S-line Harmony alzante-scorrevole.....	J.6.24
Maniglia interna S-line Harmony e vaschetta esterna alzante-scorrevole.....	J.6.25
Installazione maniglia interna S-line Harmony con mezzo cilindro alzante-scorrevole.....	J.6.26
Maniglia interna S-line Harmony con mezzo cilindro e vaschetta alzante-scorrevole.....	J.6.27
Installazione maniglia S-Line Harmony su due lati con cilindro al-	

zante-scorrevole.....	J.6.28	1-binario anta fissa soglia ribassata - installazione VS5129 e BT6026/BT6027.....	J.10.17
Assemblaggio ferramenta anta - RC2.....	J.7.1	1-binario anta fissa soglia ribassata - posizionamento anta fissa sul telaio.....	J.10.18
Ferramenta alzante-scorrevole panoramica.....	J.7.1	1-binario anta fissa soglia ribassata - BT6026/BT6027 e VS5129 superiore.....	J.10.19
Contenuto.....	J.7.2	1-binario anta fissa soglia ribassata - fissaggio con SCZ617/SCZ834.....	J.10.20
Installazione ZB0033/ZB0034/ZB0035/ZB0036.....	J.7.4	1-binario anta fissa soglia ribassata - tappo di tenuta addizionale superiore dell'anta.....	J.10.22
Preparazione chiusura meccanismo alzante-scorrevole.....	J.7.5	1-binario anta fissa soglia ribassata - tappo di tenuta superiore e cartellina anta.....	J.10.23
Installazione ZB0033/ZB0034/ZB0035/ZB0036 - no maniglia esterna opzioni.....	J.7.6	1-binario anta fissa soglia ribassata - posizionamento anta apribile sul telaio.....	J.10.24
Installazione chiusura meccanismo alzante-scorrevole.....	J.7.14	1-binario anta fissa soglia ribassata - assemblaggio tappo di tenuta superiore.....	J.10.25
Rinforzo anta - optional.....	J.8.1	Assemblaggio fine corsa.....	J.10.26
Contenuto.....	J.8.1	Operazioni finitura ante.....	J.11.1
Installazione blocco supporto VS5132 e RU9094.....	J.8.2	Contenuto.....	J.11.1
Installazione C9C001.....	J.8.3	Anta passiva schema 4 ante - tappo di tenuta.....	J.11.2
Lato ferramenta alzante-scorrevole - installazione RU9094.....	J.8.4	Anta passiva schema 4 ante - fissaggio tappo di tenuta.....	J.11.3
Lato ferramenta alzante-scorrevole - preparazione C9C001.....	J.8.5	Anta passiva schema 4 ante - posizionamento incontri di chiusura J.11.4	J.11.4
Lato ferramenta alzante-scorrevole - installazione C9C001.....	J.8.6	Anta passiva schema 4 ante - installazione guarnizione di finitura RU9704.....	J.11.5
Assemblaggio accessori anta.....	J.9.1	Inserimento finale tappo di tenuta ante alzante-scorrevole.....	J.11.6
Contenuto.....	J.9.1	Vetratura anta.....	J.12.1
Installazione distanziatore VS5131.....	J.9.2	Assemblaggio supporti vetro VS5130.....	J.12.1
Lavorazione profilato anta inserimento tappo terminali.....	J.9.3	Montaggio fermavetro per uso con VS5130.....	J.12.2
Anta standard - installazione VS9149 e RU9094.....	J.9.4	Vetratura SHI con RU0002.....	J.12.3
Anta standard - preparazione labirinto.....	J.9.5	Vetratura telaio 1-binario.....	J.13.1
Anta standard - assemblaggio labirinto.....	J.9.6	1-binario - Lavorazione fermavetri.....	J.13.3
Anta standard - installazione BT6013 e C9A001.....	J.9.7	1-binario - Vetratura SHI con RU0002.....	J.13.4
Anta fissa soglia ribassata - installazione VS9149 e RU9094.....	J.9.8	1-binario - Vetratura base con 210-055.....	J.13.5
J.9.8		1-binario - Vetratura base con 210-003.....	J.13.6
Anta fissa soglia ribassata - preparazione labirinto.....	J.9.9	Pagine di riferimento rapido.....	J.15.1
Anta fissa soglia ribassata - assemblaggio labirinto.....	J.9.10	Ferramenta alzante-scorrevole.....	J.15.1
Anta fissa soglia ribassata - installazione BT6013 e C9A001.....	J.9.11	Ferramenta alzante-scorrevole.....	J.15.3
J.9.11		2-binari drenaggio.....	J.15.5
Connessione ante alzante-scorrevole schema 4 ante - taglio verticale RU0099.....	J.9.12	3-binari drenaggio.....	J.15.6
Anta passiva schema 4 ante - preparazione del C9C002.....	J.9.13		
Anta passiva schema 4 ante - installazione tappo sigillatura inferiore.....	J.9.16		
Anta passiva schema 4 ante - installazione tappo sigillatura superiore.....	J.9.18		
Installazione ante su telai.....	J.10.1		
Contenuto.....	J.10.1		
1-binario - assemblaggio anta.....	J.10.2		
1-binario - assemblaggio cartellina copertura telaio C9A012 - inferiore.....	J.10.3		
1-binario - assemblaggio cartellina copertura telaio C9A012 - superiore.....	J.10.4		
1-binario - assemblaggio cartellina copertura telaio C9A012 - laterale.....	J.10.5		
1-binario (C9K010) - assemblaggio anta.....	J.10.6		
1-binario (C9K010) - fissaggio tappo di tenuta centrale superiore.....	J.10.7		
1-binario (C9K010) - C9A010 assemblaggio cartellina copertura telaio - inferiore.....	J.10.8		
1-binario (C9K010) - C9A010 assemblaggio cartellina copertura telaio - superiore.....	J.10.9		
1-binario (C9K010) - C9A010 assemblaggio cartellina copertura telaio - laterale.....	J.10.10		
1-binario (C9K010) - C9A010 cartellina copertura telaio schema 4 ante - inferiore.....	J.10.11		
1-binario (C9K010) - C9A010 cartellina copertura telaio schema 4 ante - superiore.....	J.10.12		
Usò standard.....	J.10.13		
Aggiustamenti.....	J.10.13		
1-binario anta fissa soglia ribassata - utilizzo VS5128/VS5129.....	J.10.13		
J.10.13			
1-binario anta fissa soglia ribassata - rimozione profilato cartellina.....	J.10.14		
J.10.14			
1-binario anta fissa soglia ribassata - installazione VS5129 e BT6015/BT6014.....	J.10.15		
J.10.15			
1-binario anta fissa soglia ribassata - blocchi guida foratura.....	J.10.16		
J.10.16			

K ALLEGATI

Limiti di impiego - alzante-scorrevole.....	K.1.1
2 ante con C9V001.....	K.1.1
2 ante con C9V051.....	K.1.2
4 ante.....	K.1.3
Valore Uf di finestre e porte.....	K.2.1

INDICE

210-003	E.3.1	GC2707	D.2.1	ZB0033	F.2.4
213-006	E.3.2	HLH301	F.2.3	ZB0033	F.2.5
215-008	E.4.4	HLH302	F.2.3	ZB0034	F.2.4
39R506	E.3.1	HLH304	F.2.3	ZB0035	F.2.4
39R507	E.3.1	HV0G03	E.1.3	ZB0038	F.1.7
39R508	E.3.1	HV0H01	E.1.3	ZB0038	F.2.1
52A28	B.6.1	HV2H06	E.1.2	ZB0040	F.2.2
71C011	E.2.1	HV2W11	E.1.1	ZB0045	F.2.1
71P003	E.4.3	HV3H26	E.1.3	ZB0046	F.2.5
71R200	E.3.3	HV4K00	E.2.2		
778-500	E.2.1	HV4K01	E.2.2		
82L538	F.1.7	KU2027	E.4.5		
BT6000	E.4.1	KU2028	E.4.5		
BT6006	E.4.2	KU2029	E.4.5		
BT6013	E.4.6	KU2035	E.4.5		
BT6015	E.4.6	KU5001	E.4.1		
BT6017	E.4.2	KU5004	E.4.1		
BT6019	E.4.2	KU6004	E.3.4		
BT6026	E.4.6	RU0002	E.3.1		
BT6027	E.4.6	RU0004	E.3.1		
C9A001	B.5.1	RU0099	E.3.4		
C9A002	B.5.1	RU9022	E.3.3		
C9A003	B.6.2	RU9079	E.3.4		
C9A004	B.6.1	RU9094	E.3.5		
C9A010	B.5.2	RU9095	E.3.2		
C9A100	B.9.1	RU9131	E.3.5		
C9A101	B.9.1	RU9703	E.3.4		
C9C001	B.4.1	RU9704	E.3.4		
C9C002	B.7.1	SCG641	E.4.11		
C9K010	B.2.1	SCZ003	E.2.1		
C9K100	B.2.1	SF3925	F.2.1		
C9K120	B.2.2	SV0032	F.2.4		
C9K121	B.2.2	SV9002	F.2.2		
C9V001	B.3.1	TG4116	G.2.2		
C9V051	B.3.2	TS3M03	E.1.4		
CO0132	E.4.10	TS3M04	E.1.4		
CO1103	E.4.6	TS9Z05	E.2.2		
CO1107	E.4.7	VS0107	E.4.7		
CO1110	E.4.8	VS5130	E.4.1		
CO1111	E.4.7	VS5128	E.4.4		
CO1114	E.4.7	VS5129	E.4.4		
CO1116	E.4.7	VS5131	E.4.4		
CO1118	E.4.11	VS5132	E.4.4		
CO1125	E.4.11	VS5135	E.4.12		
CO1136	E.4.8	VS5142	E.4.1		
CO1137	E.4.8	VS8002	E.4.12		
CO1214	E.4.8	VS8004	E.4.12		
CO2181	B.8.1	VS8005	E.4.12		
CO2206	B.8.1	VS8006	E.4.12		
CO2211	E.4.11	VS9148	E.4.10		
CO2251	E.4.13	VS9149	E.4.10		
CO2252	E.4.13	VS9163	E.4.11		
CO2253	E.4.13	VS9950	E.4.8		
CO2254	E.4.13	VS9951	E.4.9		
CO2279	E.4.3	VS9956	E.4.9		
CYL102	F.2.1	VS9957	E.4.9		
CYL318	F.2.1	VS9958	E.4.9		
D4074009	E.4.5	VS9959	E.4.9		
DHA020	F.2.3	VS9970	E.4.10		
GC0303	D.2.1	VS9971	E.4.10		
GC0307	D.2.1	Z9A016	C.2.1		
GC2310	D.2.1	Z9C005	C.2.1		
GC2312	D.2.1	Z9C030	C.2.1		
GC2315	D.2.1	ZB0024	F.2.2		
GC2317	D.2.1	ZB0025	F.2.2		
GC2320	D.2.1	ZB0027	F.2.2		
GC2322	D.2.1	ZB0028	F.2.3		
GC2325	D.2.1	ZB0029	F.2.4		
GC2327	D.2.1	ZB0030	F.2.4		
GC2330	D.2.1	ZB0031	F.2.4		
GC2703	D.2.1	ZB0032	F.2.4		

Informazioni sistema



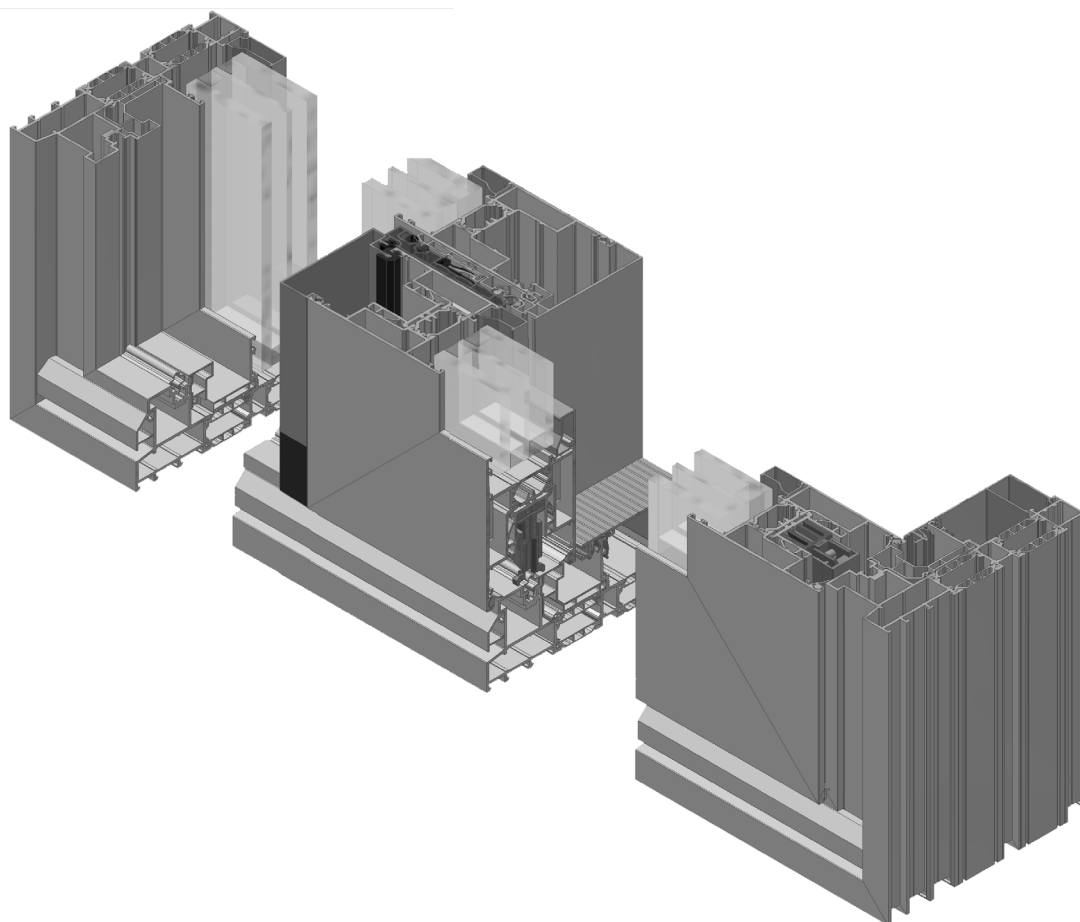

Prodotto:	Sistema termicamente isolato per finestre e porte
Applicazioni / uso:	Parti trasparenti e opache della facciata esterna per le esigenze più elevate.
Possibilità:	Adatto per ambienti riscaldati e per tutti i tipi di edifici. Secondo la norma di prodotto EN 14351-1-.
Funzioni:	Protezione dal calore, protezione climatica, protezione acustica, ventilazione.
Dimensione telaio:	160 mm
Dimensione anta:	70 mm
Altezza nodi:	Fisso: 53-60, telaio + anta: 143-159 mm, centrale: 126 mm.
Riempimenti:	Tutti i tipi di riempimenti trasparenti e opachi da 5 fino a 53 mm.
Tipi di apertura:	

Schema A

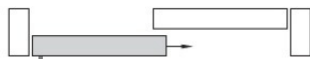

Schema C



Schema G



Schema K



Superfici:	Verniciate a polvere o anodizzate.
Drenaggio:	Cappetta di drenaggio sulla parte bassa del telaio o drenaggio nascosto.
Ulteriori possibilità:	Resistenza all'effrazione RC2
Opzioni costruttive:	Sistema modulare per miglioramento termico secondo necessità. Profiliati di finitura. Profiliati di rinforzo.
Opzioni ferramenta:	Scelta di diverse maniglie. Vedi capitolo ferramenta.

Varianti configurazioni:

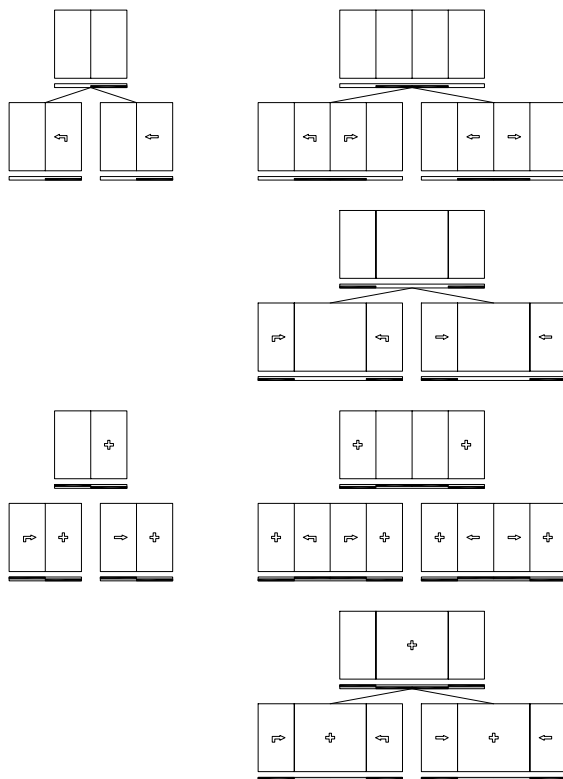

Performance:

Test	Risultati		Norme	
	sagoma omega PA 6.6 GF25 di 35 mm			
	ATG 11/H772 - ATG 11/H730			
	I: $U_f = 2.8 - 3.4 \text{ W/m}^2\text{K}$		EN ISO 10077-1	
	SI: $U_f = 2.6 - 3.2 \text{ W/m}^2\text{K}$		EN ISO 10077-1	
	SHI: $U_f = 2.09 - 3.1 \text{ W/m}^2\text{K}$		EN ISO 10077-1	
	Permeabilità aria	4	600 Pa	EN 12207
	Tenuta acqua	9A	600 Pa	EN 12208
	Resistenza vento	C4	1600 Pa	EN12210
	Test acustici	$R_w(C;Ctr) = 43(-1;-4) \text{ dB}$ con vetro $R_w(C;Ctr) = 50(-2;-5) \text{ dB}$		EN ISO 717/1
	Resistenza all'effrazione	Classe 2		ENV 1627 - 1630
	Sforzo apertura	Classe 1		EN 13115



1-BINARIO - SOGLIA RIBASSATA

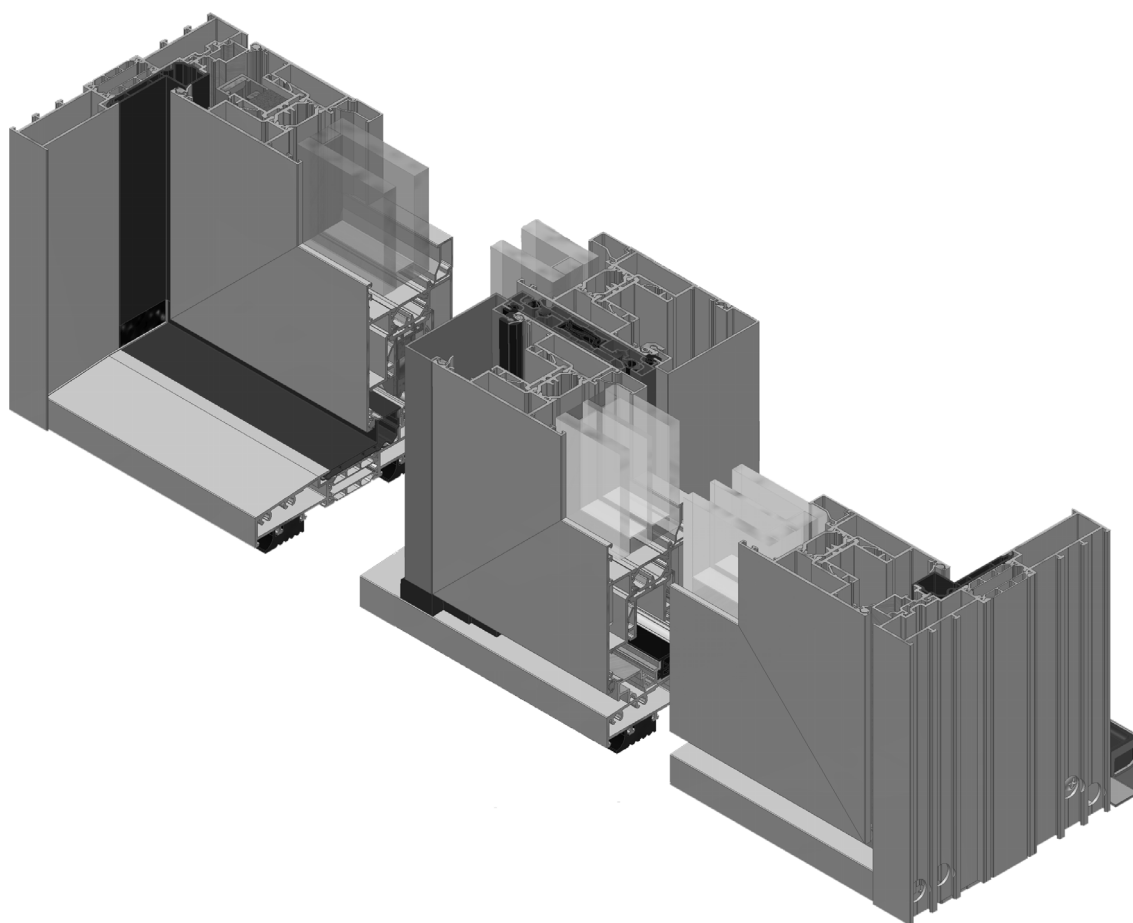

Prodotto:	Sistema termicamente isolato per finestre e porte
Applicazioni / uso:	Parti trasparenti e opache della facciata esterna per le esigenze più elevate.
Possibilità:	Adatto per ambienti riscaldati e per tutti i tipi di edifici. Secondo la norma di prodotto EN 14351-1-.
Funzioni:	Protezione dal calore, protezione climatica, protezione acustica, ventilazione.
Dimensione telaio:	160 mm
Dimensione anta:	70 mm
Altezza nodi:	Telaio + anta: 143-149 mm, centrale: 126 mm, soglia: 136-141 mm.
Riempimenti:	Tutti i tipi di riempimenti trasparenti e opachi da 5 fino a 53 mm.
Tipi apertura:	

Schema A

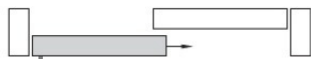

Schema C



Schema G



Schema K



Superfici:	Verniciate a polvere o anodizzate.
Drenaggio:	Cappetta di drenaggio sulla parte bassa del telaio o drenaggio nascosto.
Ulteriori possibilità:	Resistenza all'effrazione RC2
Opzioni costruttive:	Sistema modulare per miglioramento termico secondo necessità. Profiliati di finitura. Profiliati di rinforzo.
Opzioni ferramenta:	Scelta di diverse maniglie. Vedi capitolo ferramenta.

Varianti configurazioni:

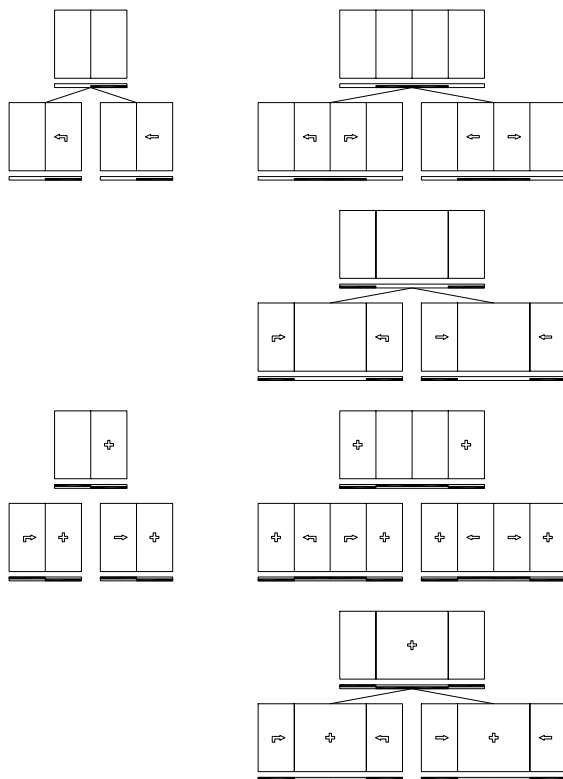

Performance:

Test	Resultati		Norme	
	Isolamento termico	sagoma omega PA 6.6 GF25 di 35 mm		
		ATG 11/H772 - ATG 11/H730		
		I: $U_f = 2.8 - 3.4 \text{ W/m}^2\text{K}$		EN ISO 10077-1
		SI: $U_f = 2.6 - 3.2 \text{ W/m}^2\text{K}$		EN ISO 10077-1
		SHI: $U_f = 2.09 - 3.1 \text{ W/m}^2\text{K}$		EN ISO 10077-1
	Permeabilità aria	600 Pa	600 Pa	EN 12207
	Tenuta acqua	250 Pa	250 Pa	EN 12208
	Resistenza vento	1600 Pa	1600 Pa	EN12210

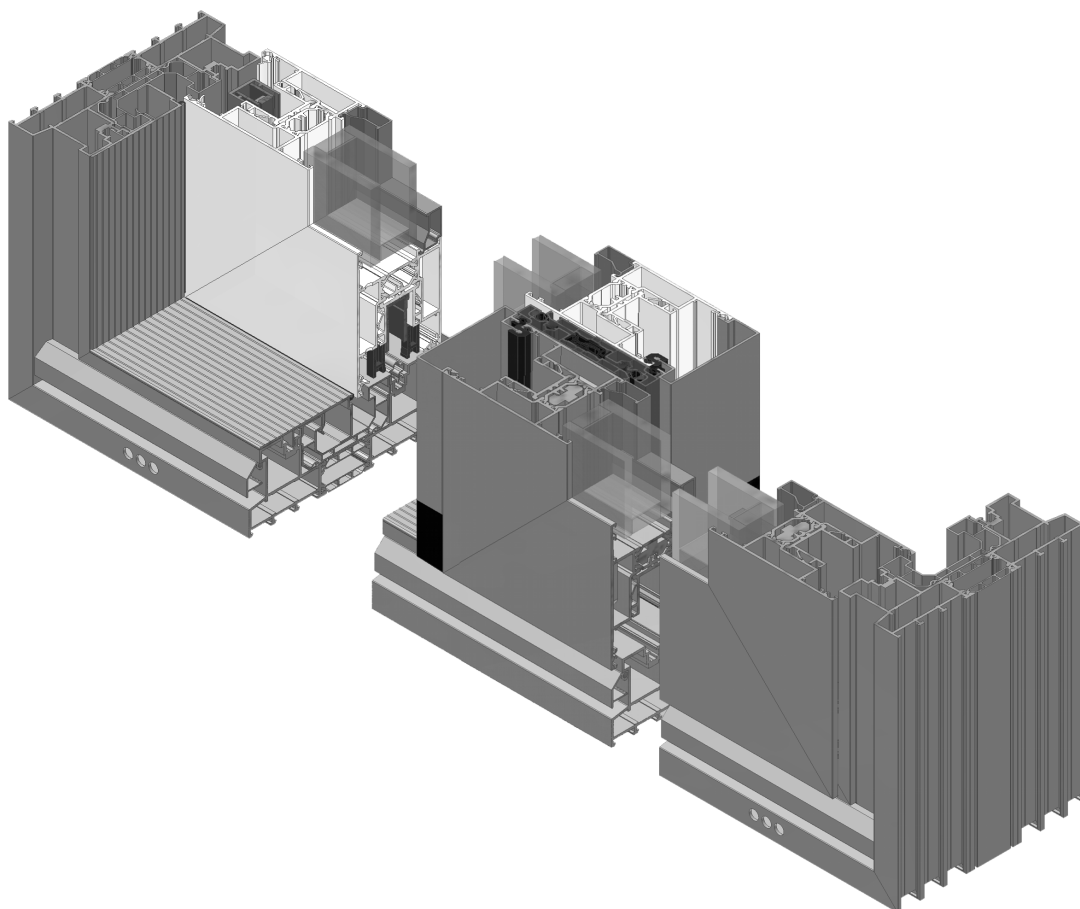

Prodotto:	Sistema termicamente isolato per finestre e porte
Applicazioni / uso:	Parti trasparenti e opache della facciata esterna per le esigenze più elevate.
Possibilità:	Adatto per ambienti riscaldati e per tutti i tipi di edifici. Secondo la norma di prodotto EN 14351-1-.
Funzioni:	Protezione dal calore, protezione climatica, protezione acustica, ventilazione.
Dimensioni telaio:	160 mm
Dimensioni ante:	70 mm
altezza nodi:	Telaio + anta: 149-159 mm, centrale: 126 mm.
Riempimenti:	Tutti i tipi di riempimenti trasparenti e opachi da 5 fino a 53 mm.
Tipi di apertura:	

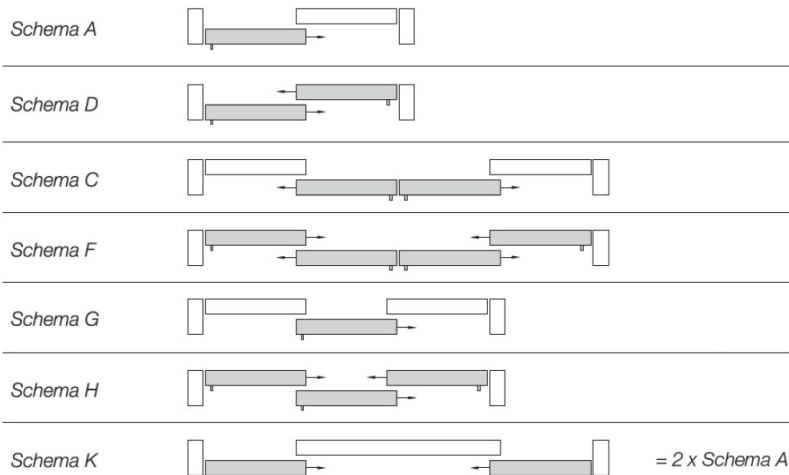

Superfici:	Verniciate a polvere o anodizzate.
Drenaggio:	Cappetta di drenaggio sulla parte bassa del telaio o drenaggio nascosto.
Ulteriori possibilità:	Resistenza all'effrazione RC2

Opzioni costruttive: Sistema modulare per miglioramento termico secondo necessità.
 Profilati di finitura.
 Profilati di rinforzo.

Opzioni ferramenta: Scelta di diverse maniglie. Vedi capitolo ferramenta.

Varianti configurazioni:

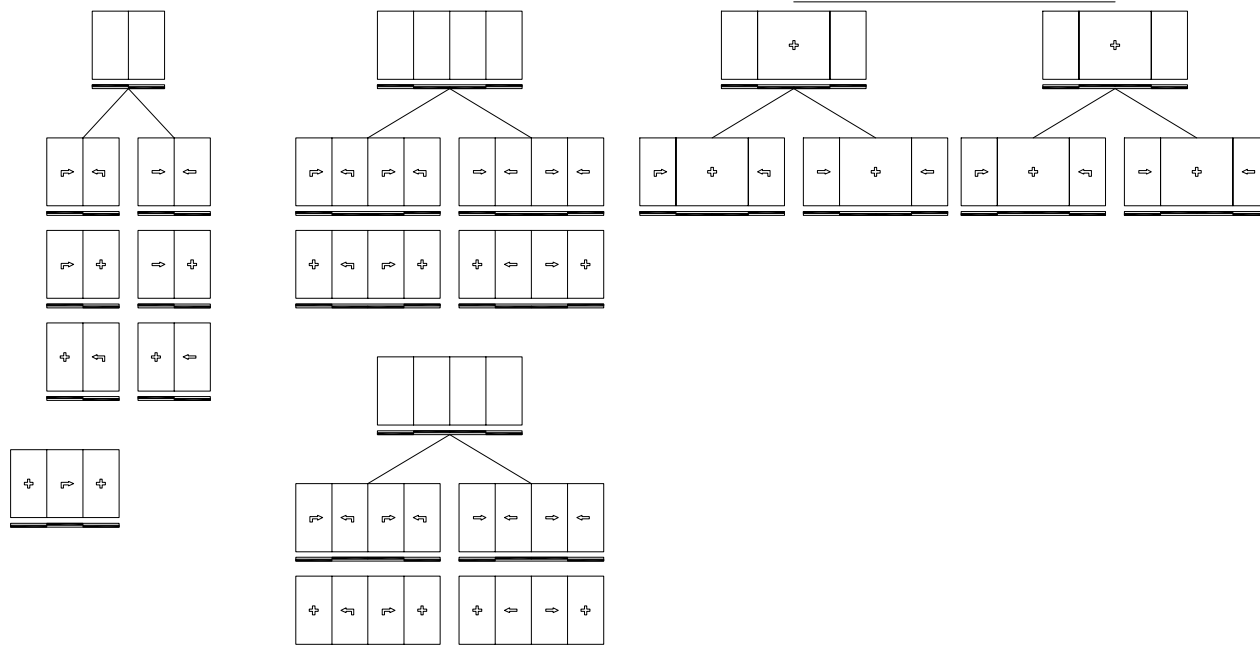

Performance:

Test	Resultati		Norme
Isolamento termico	sagoma omega PA 6.6 GF25 di 35 mm		
	ATG 11/H772 - ATG 11/H730		
	I: $U_f = 2.8 - 3.4 \text{ W/m}^2\text{K}$		EN ISO 10077-1
	SI: $U_f = 2.6 - 3.2 \text{ W/m}^2\text{K}$		EN ISO 10077-1
	SHI: $U_f = 2.09 - 3.1 \text{ W/m}^2\text{K}$		EN ISO 10077-1
Permeabilità aria	4	600 Pa	EN 12207
Tenuta acqua	E1200	1200 Pa	EN 12208
Resistenza vento	C4	1600 Pa	EN12210
Test acustici	$R_w(C;Ctr) = 42(-1;-4) \text{ dB}$ con vetro $R_w(C;Ctr) = 50(-2;-5) \text{ dB}$		EN ISO 717/1
Resistenza all'effrazione	Class 2		ENV 1627 - 1630
Sforzo apertura	Class 1		EN 13115

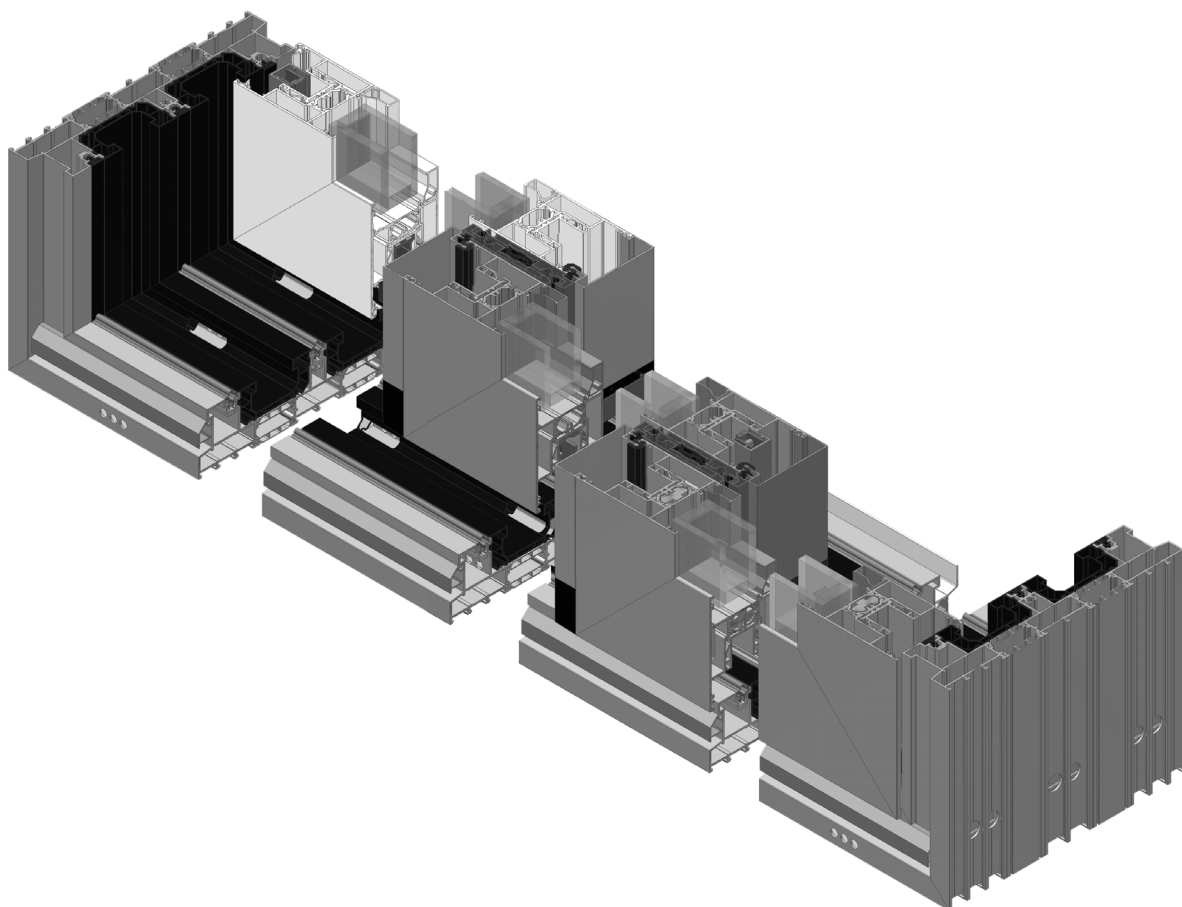

Prodotto:	Sistema termicamente isolato per finestre e porte
Applicazioni / uso:	Parti trasparenti e opache della facciata esterna per le esigenze più elevate.
Possibilità:	Adatto per ambienti riscaldati e per tutti i tipi di edifici. Secondo la norma di prodotto EN 14351-1-.
Funzioni:	Protezione dal calore, protezione climatica, protezione acustica, ventilazione.
Dimensioni telaio:	250 mm
Dimensioni ante:	70 mm
Altezza nodi:	Telaio + anta: 149-159 mm, centrale: 126 mm.
Riempimenti:	Tutti i tipi di riempimenti trasparenti e opachi da 5 fino a 53 mm.
Tipi apertura:	

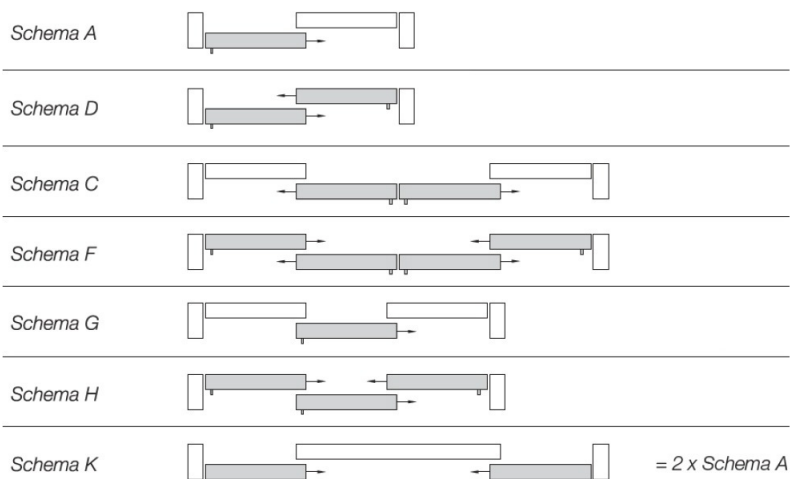

Superfici:	Verniciate a polvere o anodizzate.
Drenaggio:	Cappetta di drenaggio sulla parte bassa del telaio o drenaggio nascosto.
Ulteriori possibilità:	Resistenza all'effrazione RC2

3-BINARI



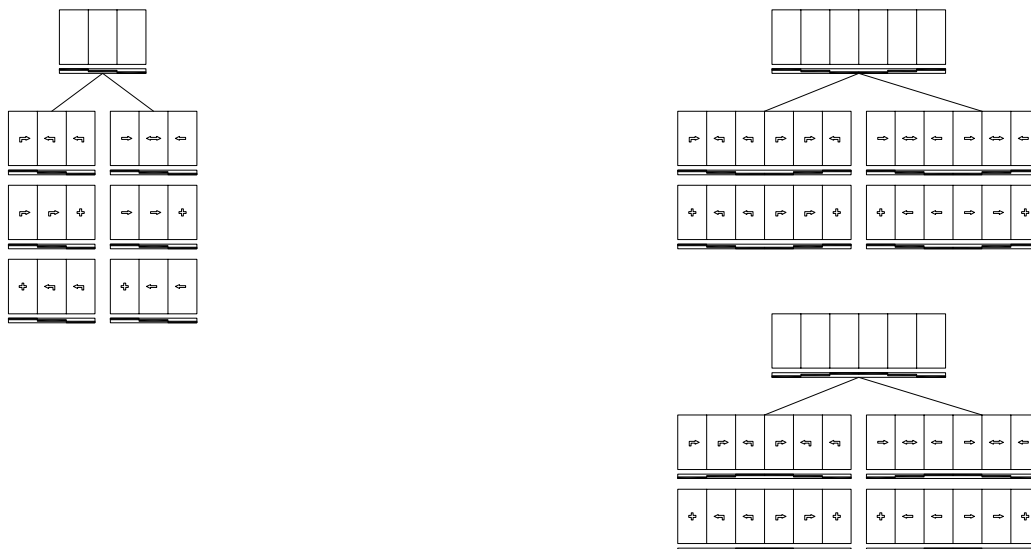

Opzioni: Sistema modulare per miglioramento termico secondo necessità.
 Profilati di finitura.
 Profilati di rinforzo.

Opzioni ferramenta: Scelta di diverse maniglie. Vedi capitolo ferramenta.

Varianti configurazioni



Performance:

Test	Resultati		Norme	
	sagoma omega PA 6.6 GF25 di 35 mm			
	ATG 11/H772 - ATG 11/H730			
	Isolamento termico	I: $U_f = 2.8 - 3.4 \text{ W/m}^2\text{K}$		EN ISO 10077-1
		SI: $U_f = 2.6 - 3.2 \text{ W/m}^2\text{K}$		EN ISO 10077-1
		SHI: $U_f = 2.09 - 3.1 \text{ W/m}^2\text{K}$		EN ISO 10077-1
	Permeabilità aria	4	600 Pa	EN 12207
	Tenuta acqua	E900	900 Pa	EN 12208
	Resistenza vento	C4	1600 Pa	EN12210

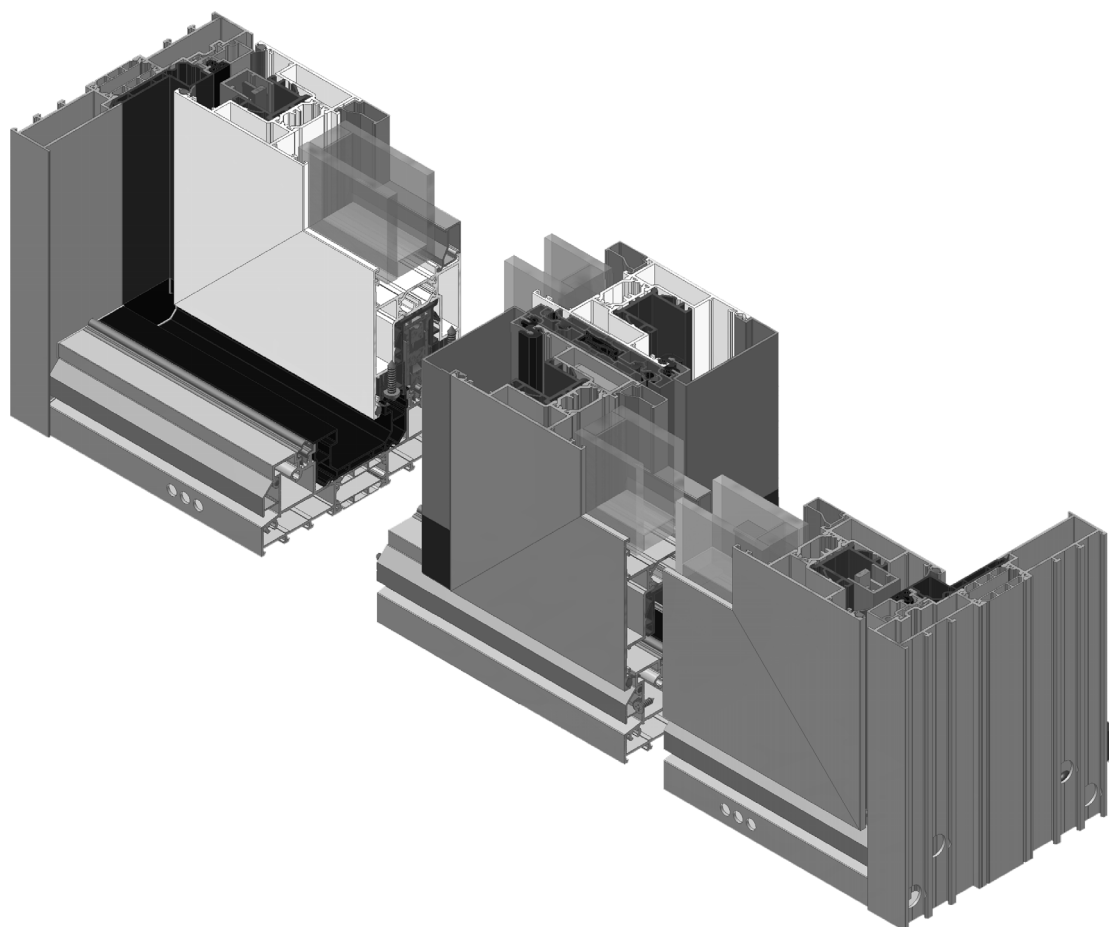

Prodotto:	Sistema termicamente isolato per finestre e porte
Applicazioni / uso:	Parti trasparenti e opache della facciata esterna per le esigenze più elevate.
Possibilità:	Adatto per ambienti riscaldati e per tutti i tipi di edifici. Secondo la norma di prodotto EN 14351-1-.
Funzioni:	Protezione dal calore, protezione climatica, protezione acustica, ventilazione.
Dimensioni telaio:	160 mm
Dimensioni ante:	70 mm
Altezza nodi:	Telaio + ante: 138-143 mm, centrale: 126 mm.
Riempimenti:	Tutti i tipi di riempimenti trasparenti e opachi da 5 fino a 53 mm.
Tipi di apertura:	

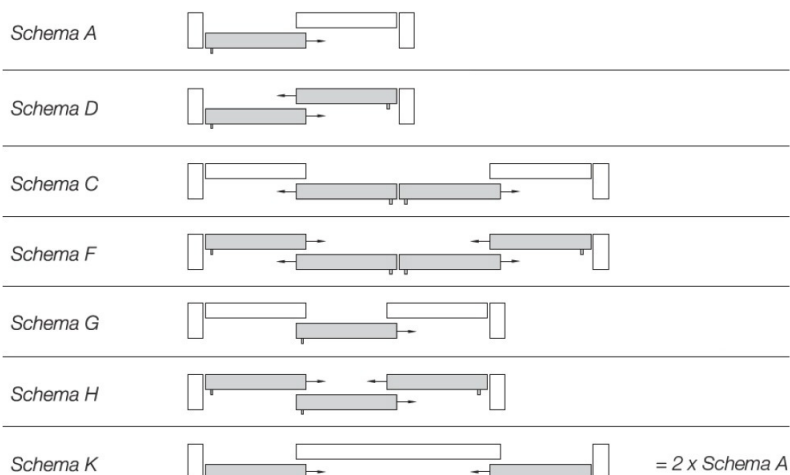

Superfici:	Verniciate a polvere o anodizzate.
Drenaggio:	Cappetta di drenaggio sulla parte bassa del telaio o drenaggio nascosto.
Ulteriori possibilità:	Resistenza all'effrazione RC2

Opzioni costruttive: Sistema modulare per miglioramento termico secondo necessità.
 Profilati di finitura.
 Profilati di rinforzo.

Opzioni ferramenta: Scelta di diverse maniglie. Vedi capitolo ferramenta.

Varianti configurazioni:

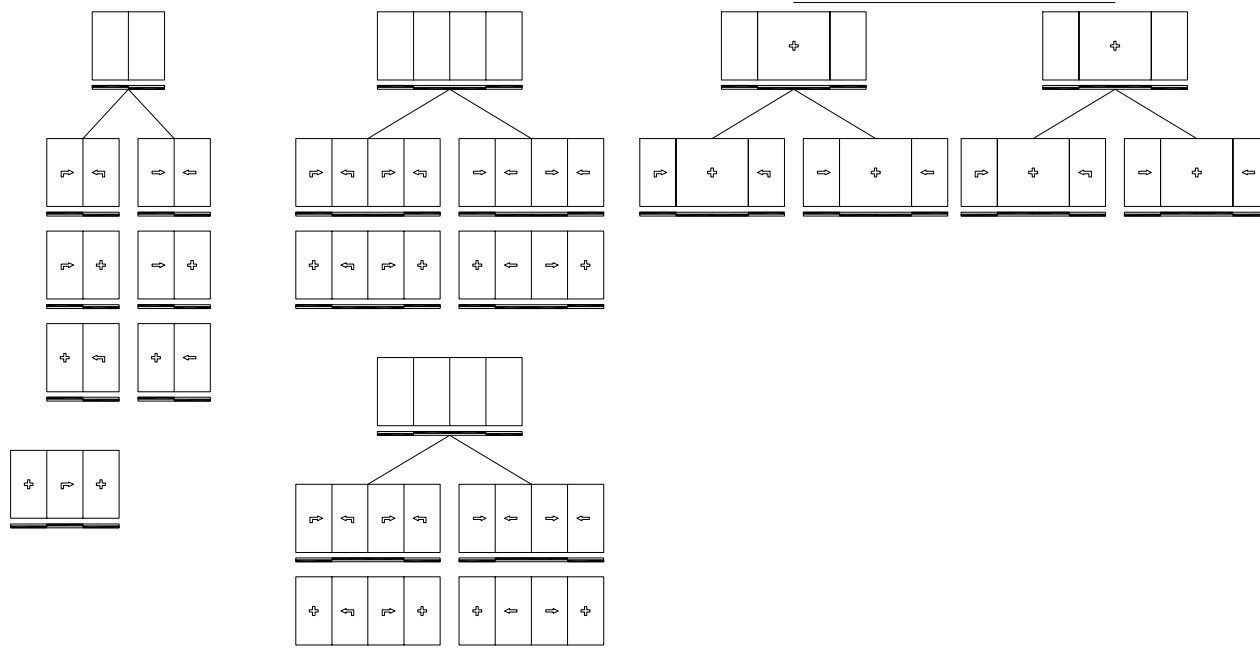

Performance:

Test	Risultati		Norme
Isolamento termico	sagoma omega PA 6.6 GF25 di 35 mm		
	ATG 11/H772 - ATG 11/H730		
	I: $U_f = 2.8 - 3.4 \text{ W/m}^2\text{K}$		EN ISO 10077-1
	SI: $U_f = 2.6 - 3.2 \text{ W/m}^2\text{K}$		EN ISO 10077-1
	SHI: $U_f = 2.09 - 3.1 \text{ W/m}^2\text{K}$		EN ISO 10077-1
Permeabilità aria	4	600 Pa	EN 12207
Tenuta acqua	E1350	1350 Pa	EN 12208
Resistenza vento	C4	1600 Pa	EN12210
Forza di apertura	Classe 1		EN 13115



OPZIONI TERMICHE

I

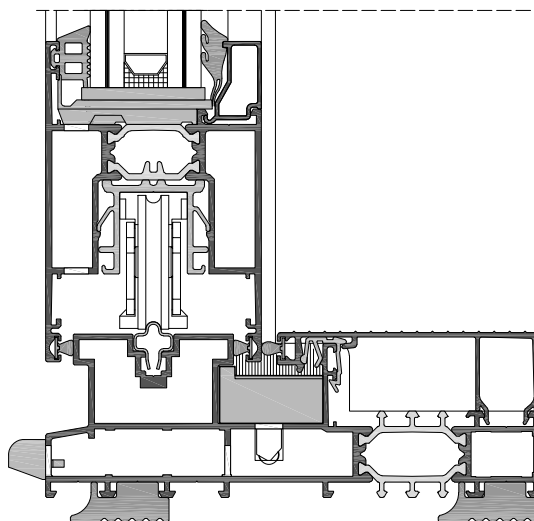

- Ferramenta montata su profilato di isolamento.
- Guarnizione per vetratura di miglioramento termico.

HI

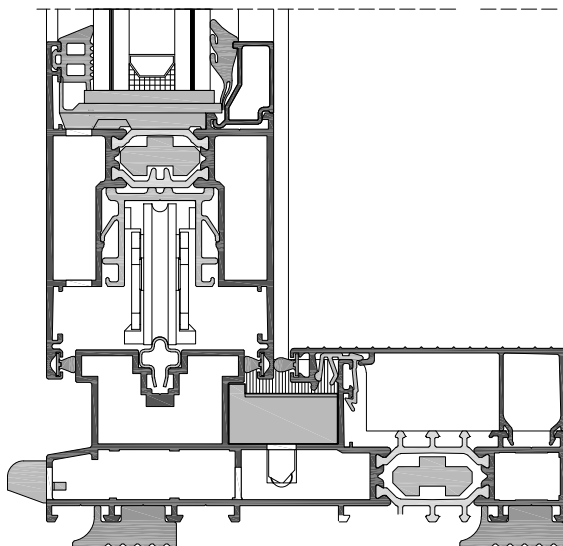

- Ferramenta montata su profilato di isolamento.
- Guarnizione per vetratura di miglioramento termico.
- PE-foam inserito nel telaio e nell'anta.

SHI

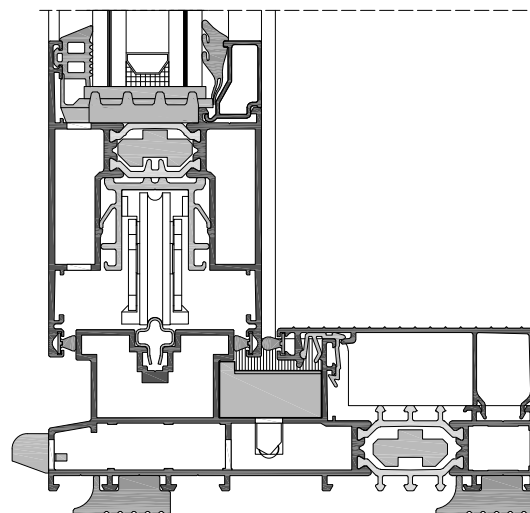

- Ferramenta montata su profilato di isolamento.
- Guarnizione per vetratura di miglioramento termico.
- PE-foam inserito nel telaio e nell'anta.
- PE-foam inserito sulla battuta del vetro.



INFORMAZIONI SISTEMA

OPZIONI TERMICHE

1. Esterno è sempre riferito alla sezione verticale orizzontale e sinistra

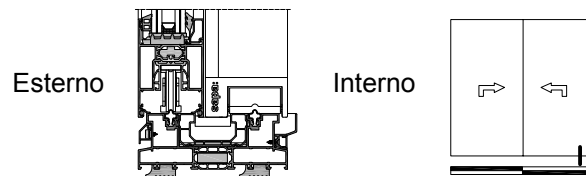
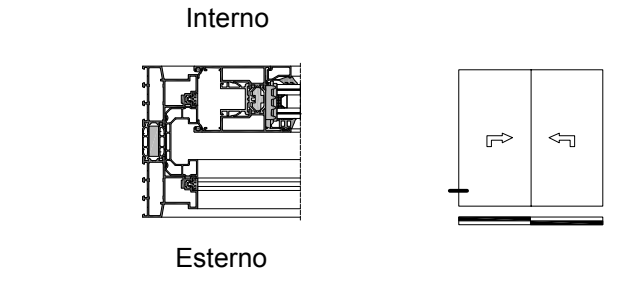

2. Tipica configurazione ante presente nel catalogo, rappresenta la 'Sinistra' secondo EN 12519:2004.

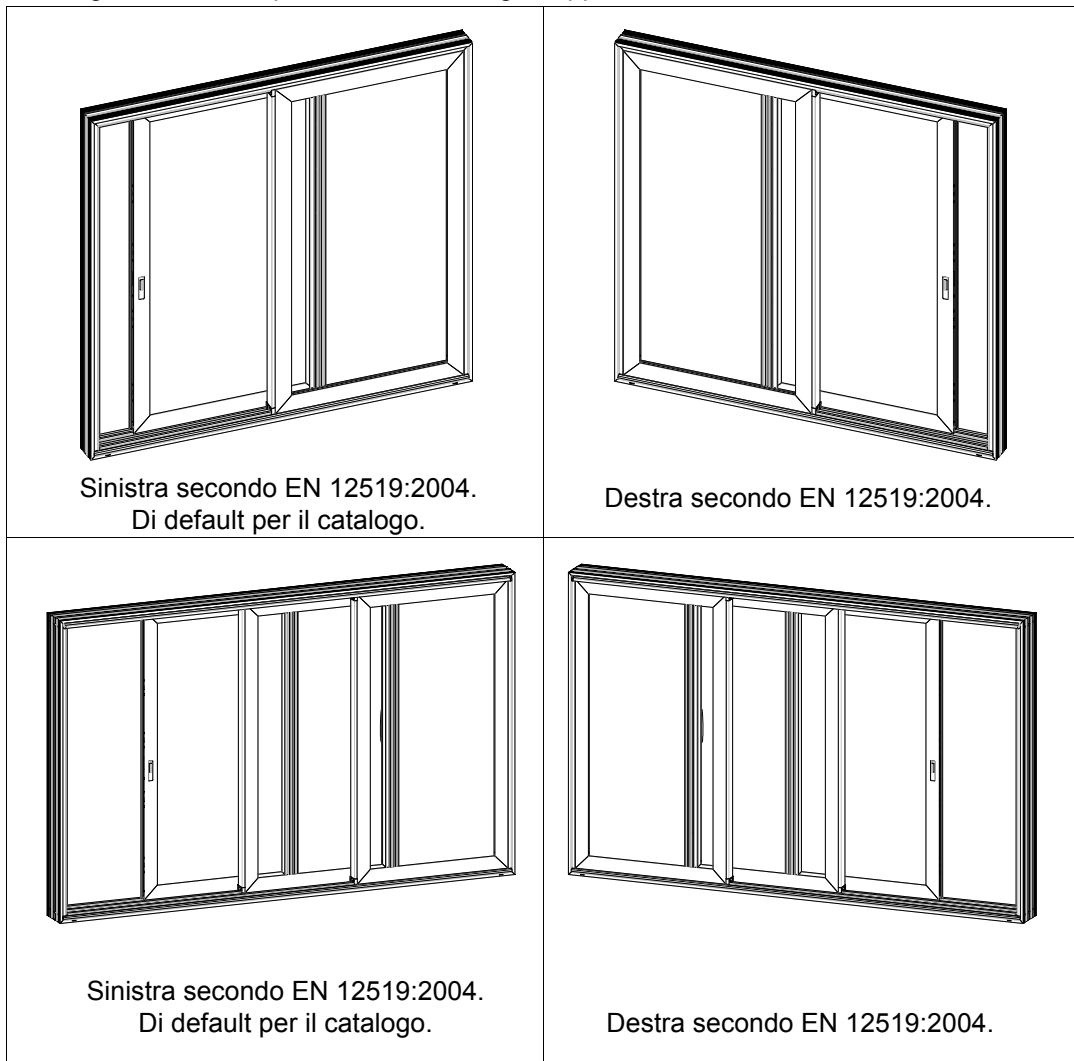

3. Applicazioni

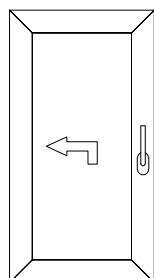

Anta alzante-scorrevole

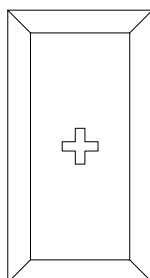

Anta fissa

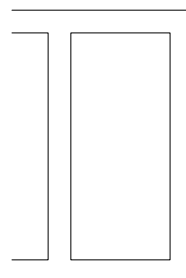









Vetro fisso



RISULTATI DEI TEST

DOCUMENTO	PAESE	NUMERO
Approvazione tecnica	Belgio	ATG 12/2872









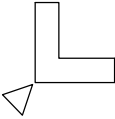
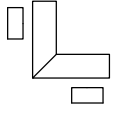

	TIPO DI FINESTRA	DIMENSIONI W x H (MM)	RISULTATI	TEST ISTITUTO NUMERO DOCUMENTO
TEST FUNZIONALI				
	2-binari alzante-scorrevole C9K020	2800 x 2400	4C, E1200A, 4 (EN12210, EN12208, EN12207)	WTCB NB 1136 CAR 10026
	2-binari 4 ante alzante- scorrevole C9K020	5150 x 2400	3C, 9A, 4 (EN12210, EN12208, EN12207)	WTCB NB 1136 CAR 10202
	1-binario alzante-scorrevole C9K010	2766 x 2388	4C, 8A, 4 (EN12210, EN12208, EN12207)	WTCB NB 1136 CAR 10178
	2-binari alzante-scorrevole finestra tagli 90 C9K120	2778 x 2400	4C, E1350A, 4 (EN12210, EN12208, EN12207)	WTCB NB 1136 CAR 11033
	3-binari alzante-scorrevole C9K030	4104 x 2400	4C, E900A, 4 (EN12210, EN12208, EN12207)	WTCB NB 1136 CAR 11032
	2-binari fisso-alzante-scorrevole- fisso	4200 x 2700	4C, 8A, 3 (EN12210, EN12208, EN12207)	LK24-1844-12-R12NK
	2-binari soglia ribassata fisso-alzante-scorrevole C9K100	2768 x 2382	4C, 6A, 4 (EN12210, EN12208, EN12207)	WTCB NB 1136 CAR 13368
	1-binario fisso-alzante-scorrevole C9K012	2800 x 2400	4C, 9A, 4 (EN12210, EN12208, EN12207)	WTCB NB 1136 CAR 14057
TEST MECCANICI				
	1-binario alzante-scorrevole finestra	2766 x 2388	Forza di funzionamento: 1 (EN 13115) Resistenza meccanica: 4 (EN 13115)	WTCB NB 1136 CAR 10178
	2-binari alzante-scorrevole finestra	2788x 2400	Forza di funzionamento: 1 (EN 13115) Resistenza meccanica: 4 (EN 13115)	WTCB NB 1136 CAR 11033
	2-binari doppia finestra alzante-scorrevole	2800x 2400	Forza di funzionamento: 1 (EN 13115) Resistenza meccanica: 4 (EN 13115)	WTCB NB 1136 CAR 10026
	2-binari fisso-alzante-scorrevole- fisso	4200 x 2700	Forza di funzionamento: 1 (EN 13115)	LK24-1844-12-R12NK

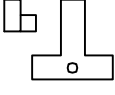
TEST ACUSTICI				
	C160 SHI - alzante-scorrevole	4100 x 2416	Rw(C;Ctr) = 37(-1;-2)dB con vetro 66.2/20/44.2 (Rw(C;Ctr)=43(-1;-5)dB)	CSTB NB 0679 AC11-26034308
	C160 SI - alzante-scorrevole	4100 x 2416	Rw(C;Ctr) = 36(-1;-2)dB con vetro 66.2/20/44.2 (Rw(C;Ctr)=43(-1;-5)dB)	CSTB NB 0679 AC11-26034308
	C160 SHI - alzante-scorrevole doppia fisso alzante-scorrevole	3950 x 2400	Rw(C;Ctr) = 42(-1;-4)dB con vetro 66.2A/20/44.2A (Rw(C;Ctr)=50(-2;-5)dB)	WTCB NB 1136 AC5581 Bis
	C160 SHI - alzante-scorrevole Doppia 2-ante	3950 x 2400	Rw(C;Ctr) = 39(-1;-3)dB con vetro 66.2A/20/44.2A (Rw(C;Ctr)=50(-2;-5)dB)	WTCB NB 1136 AC5580 Bis
	C160 SHI - alzante-scorrevole Mono	3950 x 2400	Rw(C;Ctr) = 43(-1;-4)dB con vetro 66.2A/20/44.2A (Rw(C;Ctr)=50(-2;-5)dB)	WTCB NB 1136 AC5579 Bis
	C160 SHI - alzante-scorrevole Mono	3950 x 2400	Rw(C;Ctr) = 40(-1;-3)dB con vetro 10/12/44.2A (Rw(C;Ctr)=43(-2;-5)dB)	WTCB NB 1136 AC5578 Bis
	TEST ANTIEFFRAZIONE			
	2 ante fisso-alzante-scorrevole due C9K020	2800 x 2400	Resistenza classe 2	SKG NB 0960 10.1036
	4 ante fisso-alzante-scorrevole- alzante-scorrevole-fisso due C9K020	5150 x 2400	Resistenza classe 2	SKG NB 0960 10.1110
			Dichiarazione di conformità Resistenza classe 2	SKG NB 0960 10.0925
TEST TERMICI				
			Vedi valori Uw di finestre nel capitolo K	
TEST ADDIZIONALI				
Screw connection hardware				WTCB NB 1136 CAR 10145
KOMO certificato			Resistenza classe 2	SKG NB 0960 SKG.0876.0313.04.NL

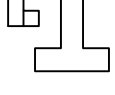



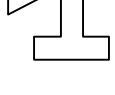
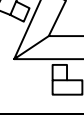

Profilati sistema



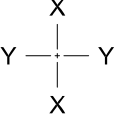

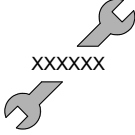
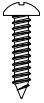

LISTA DEI SIMBOLI

A	Canali squadrette allineamento		Squadrette meccaniche
B	Tubolarità esterna per squadrette		Squadrette meccaniche fissaggio con viti
C	Tubolarità interna per squadrette		Supporti per alette
	Squadrette allineamento		Cavallotto con eccentrico tipo 1
	Squadrette a cianfrinare		Cavallotto con eccentrico tipo 2
	Squadrette a spinare		Cavallotto angolo variabile con eccentrico
	Squadrette con eccentrico		Cavallotto a spinare
	Squadretta angolo variabile con eccentrico		Cavallotto angolo variabile a spinare
			Piatto blindatura

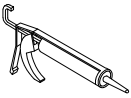

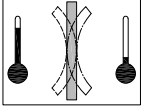

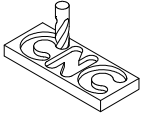
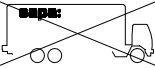
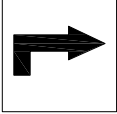









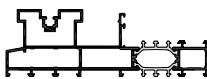







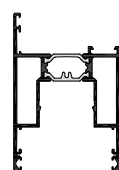

LISTA DEI SIMBOLI

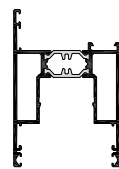

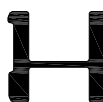

	Numero pagina
	Posizione del profilato
	Lunghezza del profilato (m)
Ixx Iyy	Momento di inerzia secondo assi XX/YY (cm ⁴)
	Superficie anodizzata o verniciata (dm ² /m)
	Superficie di pulizia (dm ² /m)
 xxxxxx	Codice attrezzo
	Collegamento a vite
 X.X.X	Vedi disegno
 xxxxxx	Numero confezione
 xxxxxx	Pezzi nella confezione



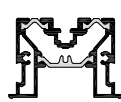

	Silicone, colla
	Rompere o tagliare
	Unità di misura confezione
	Effetto bi-metallo
	Resistenza all'effrazione, classe Europea 2
	CNC centro di lavoro
	Non fornito da Domal
	Soluzione alzante-scorrevole









LISTA PROFILATI











TELAIO			PROFILATI CARTELLINE		
	CODICE			CODICE	
	C9K010	B.2.1		C9A001	B.5.1
	C9K100	B.2.1		C9A002	B.5.1
	C9K120	B.2.2		C9A010	B.5.2
	C9K121	B.2.2	PROFILATI GOCCIOLATOI		
	CODICE			CODICE	
	C9V001	B.3.1		52A28	B.6.1
	C9V051	B.3.2		C9A004	B.6.1
	C9C001	B.4.1		C9A003	B.6.2
	CODICE			CODICE	
	C9C002	B.7.1	PROFILATI GUIDA		

PROFILATI COMPLEMENTARI		
	CODICE	
	CO2206	B.8.1
	CO2181	B.8.1

BINARI ADDIZIONALI		
	CODICE	
	C9A100	B.9.1
	C9A101	B.9.1





FERMAVETRO - STANDARD - 22 MM		
	CODICE	
	GC0303	D.2.1
	GC0307	D.2.1

FERMAVETRO - TUBOLARI - 22 MM		
	CODICE	
	GC2310	D.2.1

FERMAVETRO - TUBOLARI - 22 MM		
	CODICE	
	GC2312	D.2.1
	GC2315	D.2.1
	GC2317	D.2.1
	GC2320	D.2.1
	GC2322	D.2.1
	GC2325	D.2.1
	GC2327	D.2.1
	GC2330	D.2.1



LISTA PROFILATI

FINESTRE - PROFILATI DI FINITURA		
	CODICE	
	Z9A016	C.2.1
	Z9C005	C.2.1
	Z9C030	C.2.1



PROFILATI SISTEMA

LISTA PROFILATI



C9K010

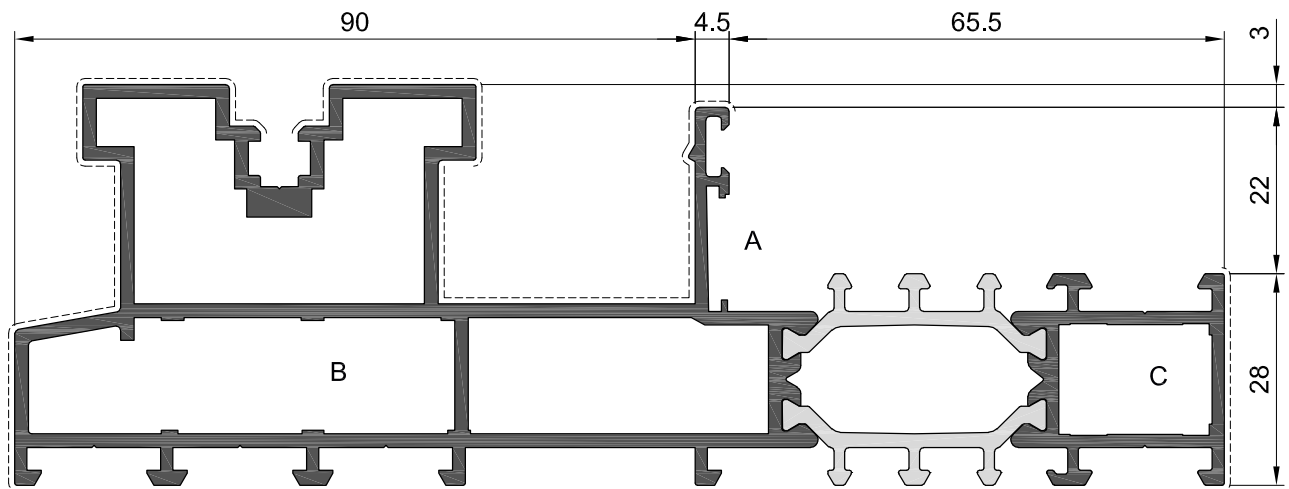

	dm ² /m	64.27	A		HV4K01	C		HV1H03	-	-		J.2.1	
	dm ² /m	24.98	B		HV0G03	-	-	-	-	-		H.1.2	
	lyy cm ⁴	25.41	C		HV0H01	-	-	-	-	-		7.0	
	mm	800	1000	1200	1400	1600	1800	2000	2200	2400	2600	2800	3000
	lxx cm ⁴	116.59	129.53	142.11	153.74	164.17	173.34	181.30	188.17	194.08	199.17	203.55	207.34

100%

C9K100

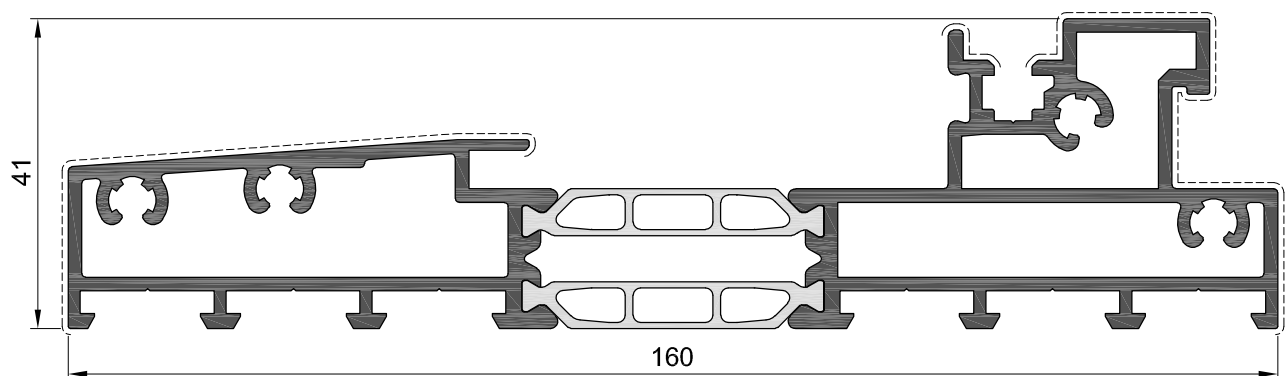

	dm ² /m	52.90	-	-	-	-	-	-	-	-		J.3.9	
	dm ² /m	18.19	-	-	-	-	-	-	-	-		H.1.6	
	lyy cm ⁴	10.84	-	-	-	-	-	-	-	-		7.0	
	mm	800	1000	1200	1400	1600	1800	2000	2200	2400	2600	2800	3000
	lxx cm ⁴	73.10	89.00	105.34	121.32	136.40	150.29	162.87	174.14	184.15	193.02	200.86	207.78

C9K120

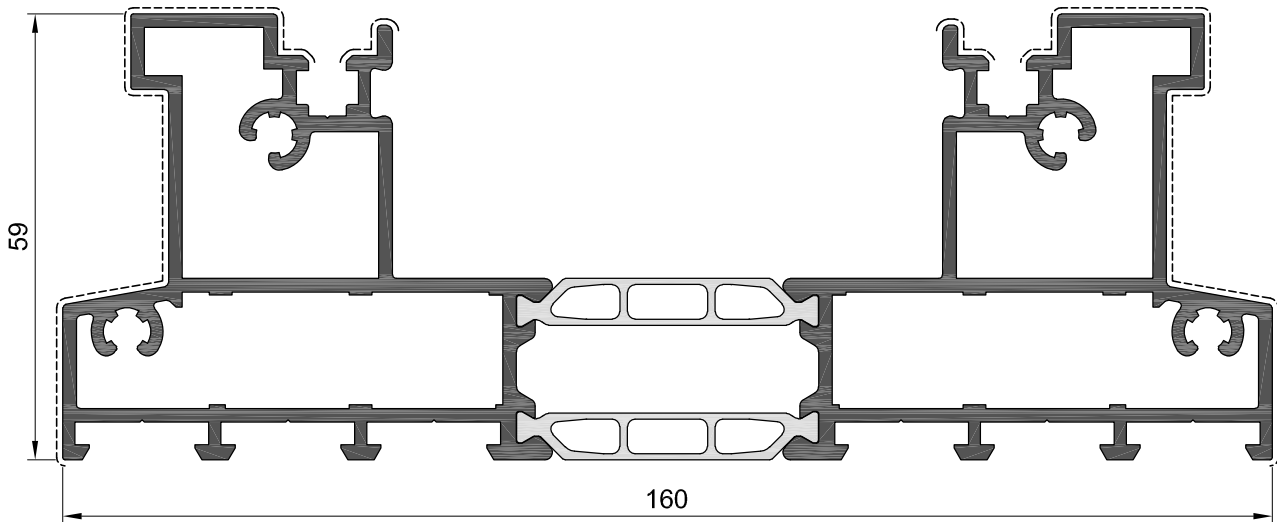

dm ² /m	64.49	B		HV0G03	C		HV2W11	-	-		J.3.8	
dm ² /m	23.01	B		HV2W11	-	-	-	-	-		-	
lyy cm ⁴	43.08	C		HV0G03	-	-	-	-	-	m	7.0	
mm	800	1000	1200	1400	1600	1800	2000	2200	2400	2600	2800	3000
lxx cm ⁴	61.85	72.00	83.52	96.00	109.09	122.46	135.83	148.97	161.73	173.97	185.62	196.64

C9K121

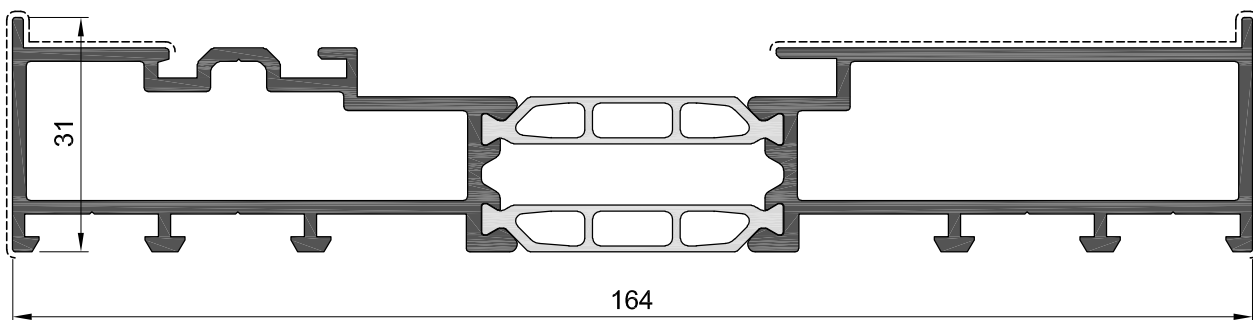

dm ² /m	49.79	-	-	-	-	-	-	-	-		J.3.4	
dm ² /m	15.40	-	-	-	-	-	-	-	-		H.1.8	
lyy cm ⁴	6.97	-	-	-	-	-	-	-	-	m	7.0	
mm	800	1000	1200	1400	1600	1800	2000	2200	2400	2600	2800	3000
lxx cm ⁴	55.89	64.77	74.45	84.49	94.55	104.35	113.72	122.54	130.74	138.30	145.23	151.56

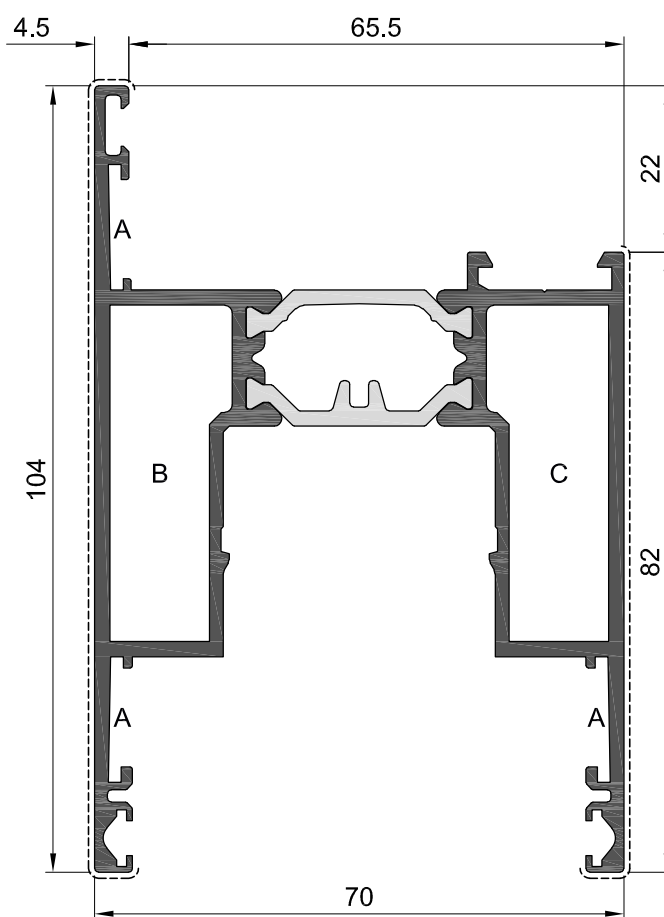

C9V001

	dm ² /m	55.07	A		HV4K01	C		HV2W10	-	-		J.4.1	
	dm ² /m	20.09	B		HV2W10	C		HV3H26	-	-		-	
	l _{yy} cm ⁴	48.12	B		HV3H26	-	-	-	-	-		7.0	
	mm	800	1000	1200	1400	1600	1800	2000	2200	2400	2600	2800	3000
	l _{xx} cm ⁴	15.23	19.51	23.77	27.79	31.48	34.78	37.7	40.25	42.48	44.42	46.1	47.57





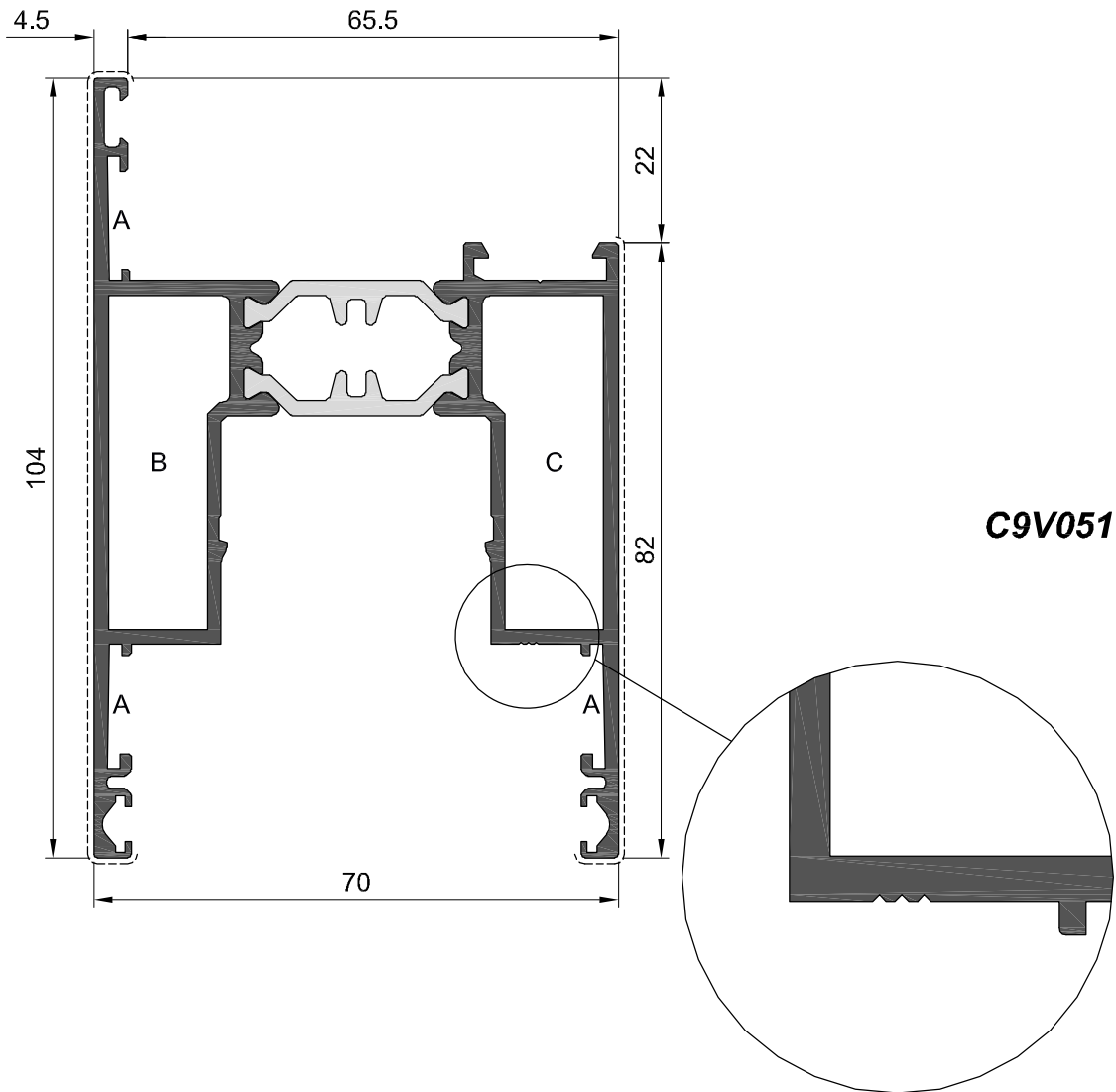



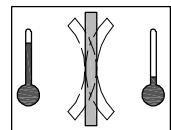





Profilato effetto bi-metal



C9V051



 dm ² /m	55.07	A 	HV4K01	C 	HV2W10	-	-		J.4.1			
 dm ² /m	20.09	B 	HV2W10	C 	HV3H26	-	-		-			
 lyy cm ⁴	4.97	B 	HV3H26	-	-	-	-	 m	7.0			
mm	800	1000	1200	1400	1600	1800	2000	2200	2400	2600	2800	3000
 lxx cm ⁴	4.97	4.97	4.97	4.97	4.97	4.97	4.97	4.97	4.97	4.97	4.97	4.97

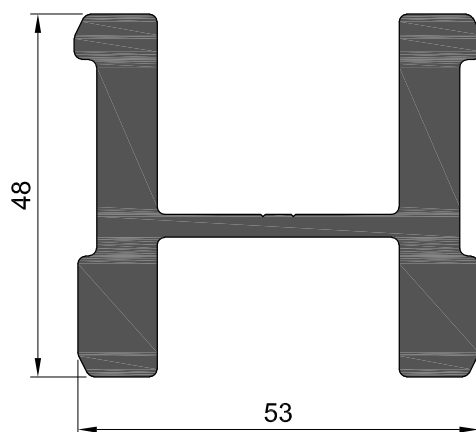

C9C001

	dm ² /m	29.25	-	-	-	-	-	-	-	-		J.8.3	
	dm ² /m	0.00	-	-	-	-	-	-	-	-		H.1.13	
	lyy cm ⁴	18.10	-	-	-	-	-	-	-	-		m	7
	mm	800	1000	1200	1400	1600	1800	2000	2200	2400	2600	2800	3000
	lxx cm ⁴	-	38.75	-	-	-	-	-	-	-	-	-	-



PROFILATI SISTEMA

RINFORZO

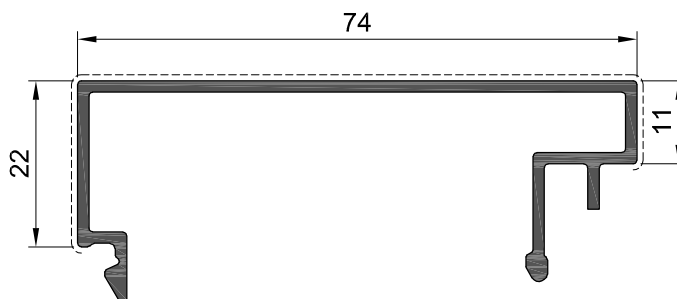

C9A001

	dm ² /m	30.22	-	-	-	-	-	-	-	-		J.9.7	
	dm ² /m	10.71	-	-	-	-	-	-	-	-		H.1.2	
	lyy cm ⁴	1.78	-	-	-	-	-	-	-	-		m 6.0	
	mm	800	1000	1200	1400	1600	1800	2000	2200	2400	2600	2800	3000
	lxx cm ⁴	-	17.28	-	-	-	-	-	-	-	-	-	-

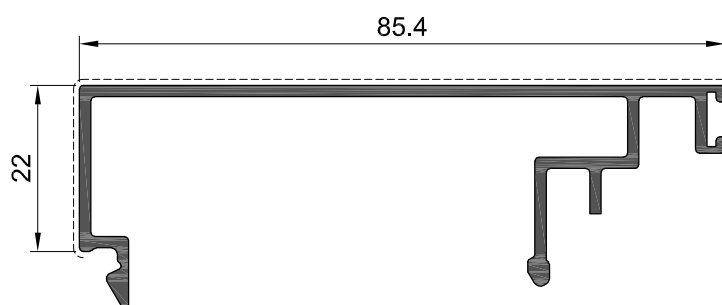

C9A002



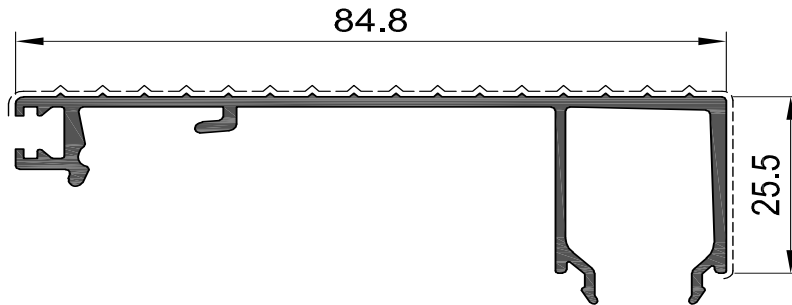



	dm ² /m	34.99	-	-	-	-	-	-	-	-		J.2.38	
	dm ² /m	11.01	-	-	-	-	-	-	-	-		-	
	lyy cm ⁴	1.88	-	-	-	-	-	-	-	-		m 6.0	
	mm	800	1000	1200	1400	1600	1800	2000	2200	2400	2600	2800	3000
	lxx cm ⁴	-	22.92	-	-	-	-	-	-	-	-	-	-



C9A010







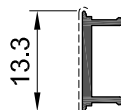



75%

 dm ² /m	35.83	-	-	-	-	-	-	-	-	-		-
 dm ² /m	11.99	-	-	-	-	-	-	-	-	-		H.1.2
 lyy cm ⁴	1.90	-	-	-	-	-	-	-	-	-	 m	7.0
mm	800	1000	1200	1400	1600	1800	2000	2200	2400	2600	2800	3000
 lxx cm ⁴	-	23.41	-	-	-	-	-	-	-	-	-	-







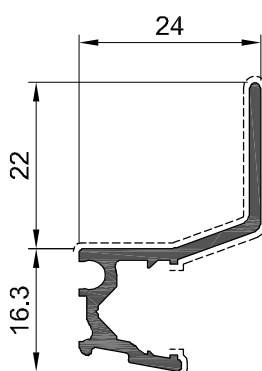



52A28

 dm ² /m	4.52	-	-	-	-	-	-	-	-	-		-
 dm ² /m	1.38	-	-	-	-	-	-	-	-	-		-
 l _{yy} cm ⁴	0.04	-	-	-	-	-	-	-	-	-	 m	7
 mm	800	1000	1200	1400	1600	1800	2000	2200	2400	2600	2800	3000
 l _{xx} cm ⁴	-	0.00	-	-	-	-	-	-	-	-	-	-



C9A004

 dm ² /m	14.64	-	-	-	-	-	-	-	-	-		-
 dm ² /m	7.87	-	-	-	-	-	-	-	-	-		-
 l _{yy} cm ⁴	1.08	-	-	-	-	-	-	-	-	-	 m	7.0
 mm	800	1000	1200	1400	1600	1800	2000	2200	2400	2600	2800	3000
 l _{xx} cm ⁴	-	0.80	-	-	-	-	-	-	-	-	-	-

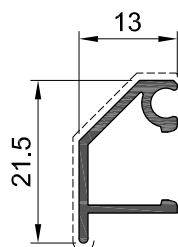

C9A003

dm ² /m	9.83	-	-	-	-	-	-	-	-	-	J.2.29	
dm ² /m	4.58	-	-	-	-	-	-	-	-	-	-	
lyy cm ⁴	0.25	-	-	-	-	-	-	-	-	-	m 7.0	
mm	800	1000	1200	1400	1600	1800	2000	2200	2400	2600	2800	3000
lxx cm ⁴	-	0.11	-	-	-	-	-	-	-	-	-	-

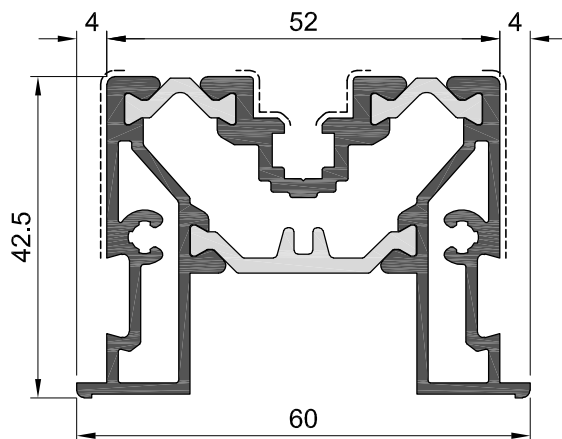

C9C002

	dm ² /m	15.02	-	-	-	-	-	-	-	-		J.9.13	
	dm ² /m	6.26	-	-	-	-	-	-	-	-		H.1.11	
	lyy cm ⁴	6.07	-	-	-	-	-	-	-	-		m	7.0
	mm	800	1000	1200	1400	1600	1800	2000	2200	2400	2600	2800	3000
	lxx cm ⁴	3.75	5.03	6.23	7.54	8.66	9.68	10.58	11.37	12.06	12.66	13.19	13.65



PROFILATI SISTEMA

PROFILATI GUIDA



PROFILATI COMPLEMENTARI

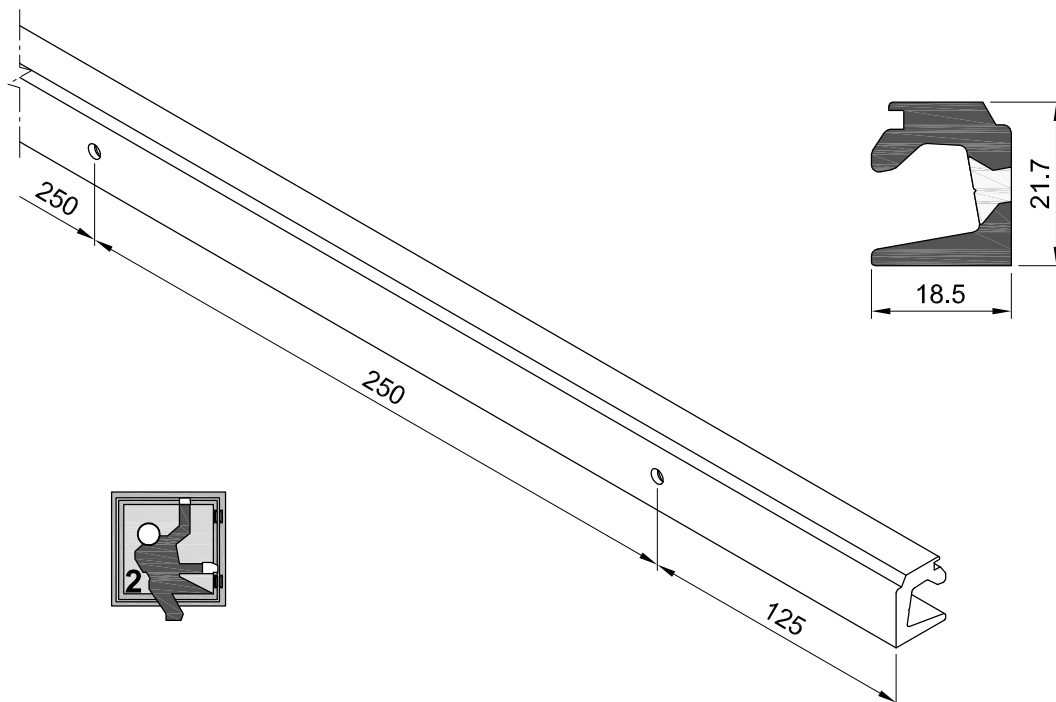

CO2206

	dm ² /m	10.92	-	-	-	-	-	-	-	-		-	
	dm ² /m	6.49	-	-	-	-	-	-	-	-		-	
	lyy cm ⁴	0.60	-	-	-	-	-	-	-	-		m 7	
	mm	800	1000	1200	1400	1600	1800	2000	2200	2400	2600	2800	3000
	lxx cm ⁴	-	1.12	-	-	-	-	-	-	-	-	-	-

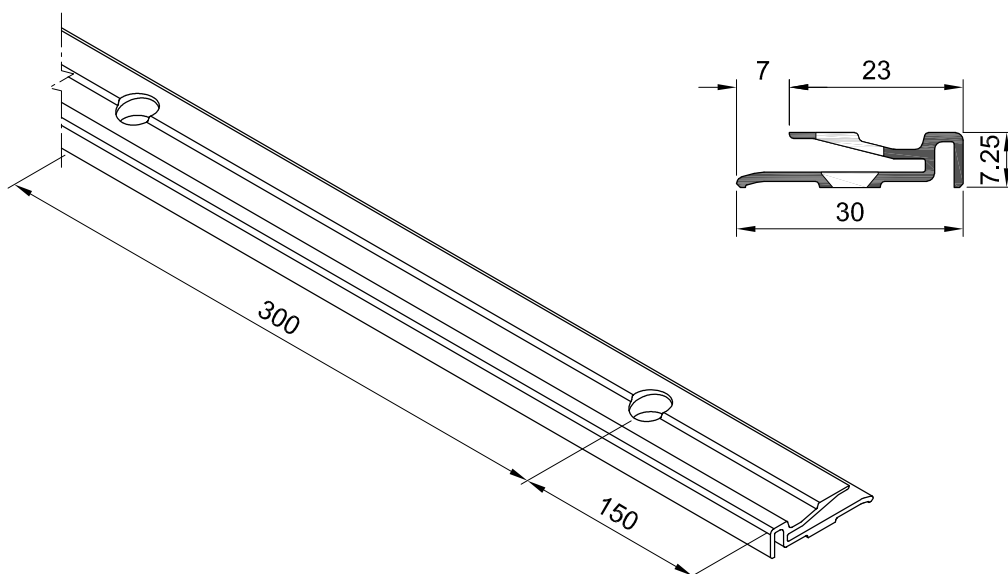

CO2181

	dm ² /m	11.95	-	-	-	-	-	-	-	-		-	
	dm ² /m	3.86	-	-	-	-	-	-	-	-		-	
	lyy cm ⁴	0.04	-	-	-	-	-	-	-	-		m 3	
	mm	800	1000	1200	1400	1600	1800	2000	2200	2400	2600	2800	3000
	lxx cm ⁴	-	0.50	-	-	-	-	-	-	-	-	-	-



PROFILATI SISTEMA

PROFILATI COMPLEMENTARI

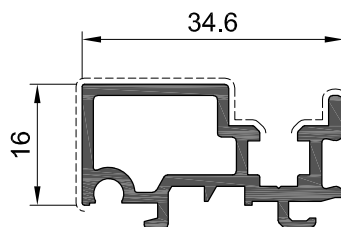

C9A100

	dm ² /m	17.11	-	-	-	-	-	-	-	-		J.3.34	
	dm ² /m	5.59	-	-	-	-	-	-	-	-		H.1.8	
	lyy cm ⁴	0.59	-	-	-	-	-	-	-	-		7.0	
	mm	800	1000	1200	1400	1600	1800	2000	2200	2400	2600	2800	3000
	lxx cm ⁴	-	2.25	-	-	-	-	-	-	-	-	-	-

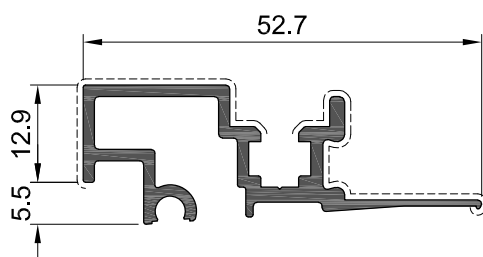

C9A101

	dm ² /m	24.33	-	-	-	-	-	-	-	-		J.3.23	
	dm ² /m	4.21	-	-	-	-	-	-	-	-		H.1.7	
	lyy cm ⁴	0.58	-	-	-	-	-	-	-	-		7.0	
	mm	800	1000	1200	1400	1600	1800	2000	2200	2400	2600	2800	3000
	lxx cm ⁴	-	3.56	-	-	-	-	-	-	-	-	-	-



PROFILATI SISTEMA

BINARI ADDIZIONALI



MOMENTO DI INERZIA

	I _{xx} (CM ⁴)											
	LUNGHEZZA [MM]											
	800	1000	1200	1400	1600	1800	2000	2200	2400	2600	2800	3000
C9C002	3.75	5.03	6.23	7.54	8.66	9.68	10.58	11.37	12.06	12.66	13.19	13.65
C9C003	6.91	8.91	11.05	13.21	15.31	17.32	19.19	20.91	22.47	23.89	25.17	26.32
C9K010	116.59	129.53	142.11	153.74	164.17	173.34	181.30	188.17	194.08	199.17	203.55	207.34
C9K100	73.10	89.00	105.34	121.32	136.40	150.29	162.87	174.14	184.15	193.02	200.86	207.78
C9K120	61.85	72.00	83.52	96.00	109.09	122.46	135.83	148.97	161.73	173.97	185.62	196.64
C9K121	55.89	64.77	74.45	84.49	94.55	104.35	113.72	122.54	130.74	138.30	145.23	151.56
C9V001	15.23	19.51	23.77	27.79	31.48	34.78	37.7	40.25	42.48	44.42	46.1	47.57
C9V051	4.97	4.97	4.97	4.97	4.97	4.97	4.97	4.97	4.97	4.97	4.97	4.97



PROFILATI SISTEMA

MOMENTO DI INERZIA

Profilati vari



PROFILATI VARI



FINESTRE - PROFILATI DI FINITURA

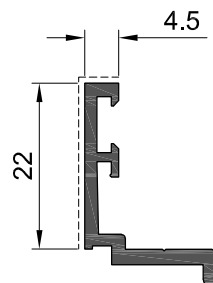
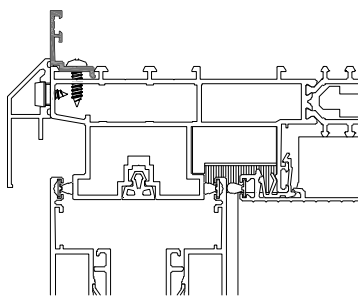

Z9A016

(dm ² /m)	10.9
(dm ² /m)	2.65
$\gamma \frac{x}{x} \gamma$ Ixx (cm ⁴)	0.27
$\gamma \frac{x}{x} \gamma$ Iyy (cm ⁴)	0.59
-	m 6.0

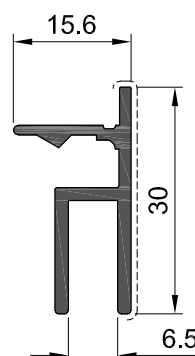
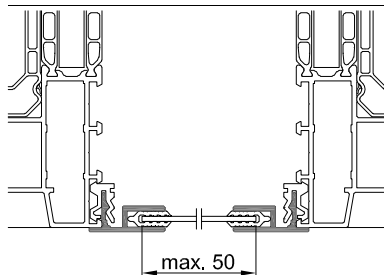

Z9C005

(dm ² /m)	13.86
(dm ² /m)	3.35
$\gamma \frac{x}{x} \gamma$ Ixx (cm ⁴)	0.21
$\gamma \frac{x}{x} \gamma$ Iyy (cm ⁴)	0.78
-	m 6.0

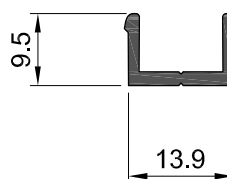
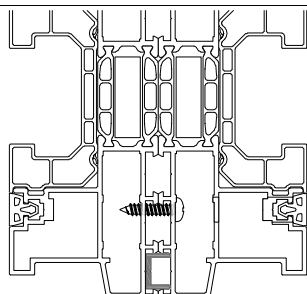

Z9C030

(dm ² /m)	6.24
(dm ² /m)	0
$\gamma \frac{x}{x} \gamma$ Ixx (cm ⁴)	0.13
$\gamma \frac{x}{x} \gamma$ Iyy (cm ⁴)	0.04
-	m 6.0



PROFILATI VARI

FINESTRE - PROFILATI DI FINITURA

Vetratura

SCELTA FERMAVETRI E GUARNIZIONI



- Lo spessore del vetro dipende da:
 - * pressione dinamica base del vento
 - * caratteristiche della vetratura, sue dimensioni e applicazioni
 - * applicazione
 - * posizione
- Il vetro e la sua installazione devono essere conformi alle direttive vigenti e le specifiche del produttore autorizzato (vetro isolante deve avere una licenza tecnica)
- Prima della installazione dell vetro verificarne lo spessore, le dimensioni e la geometria dei volumi con le direttive e specifiche.



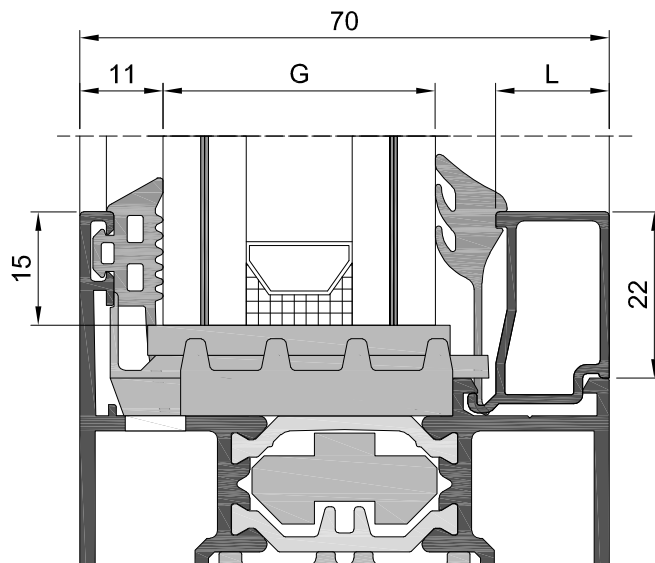

TABELLA VETRATURA

VETRATURA CON RU0004





G (MM)				L (MM)	
	39R506	39R507	39R508		
	4 - 6 MM	6 - 7.5 MM	7.5 - 9 MM		
23		•		30	GC2330
24			•	27.5	GC2327
25		•		27.5	GC2327
26	•			27.5	GC2327
27		•		25	GC2325
28		•		25	GC2325
29			•	22.5	GC2322
30		•		22.5	GC2322
31	•			22.5	GC2322
32		•		20	GC2320
33		•		20	GC2320
34			•	17.5	GC2317
35		•		17.5	GC2317
36	•			17.5	GC2317
37		•		15	GC2315
38		•		15	GC2315
39			•	12.5	GC2312
40		•		12.5	GC2312
41	•			12.5	GC2312
42		•		10	GC2310
43		•		10	GC2310

G (MM)				L (MM)	
	39R506	39R507	39R508		
	4 - 6 MM	6 - 7.5 MM	7.5 - 9 MM		
44			•	7.5	GC0307
45		•		7.5	GC0307
46	•			7.5	GC0307
49		•		3	GC0303
50		•		3	GC0303

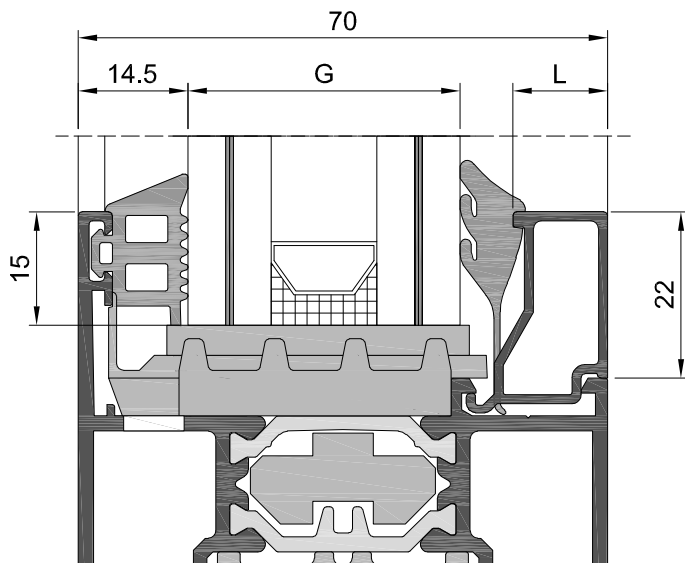
VETRATURA CON RU0002



G (MM)	☞			L (MM)	 TUBOLARE CLASSIC
	39R506	39R507	39R508		
	4 - 6 MM	6 - 7.5 MM	7.5 - 9 MM		
23			•	25	GC2325
24		•		25	GC2325
25	•			25	GC2325
26		•		22.5	GC2322
27		•		22.5	GC2322
28			•	20	GC2320
29		•		20	GC2320
30	•			20	GC2320
31		•		17.5	GC2317
32		•		17.5	GC2317
33			•	15	GC2315
34		•		15	GC2315
35	•			15	GC2315
36		•		12.5	GC2312
37		•		12.5	GC2312
38			•	10	GC2310
39		•		10	GC2310
40	•			10	GC2310

G (MM)	☞			L (MM)	 STANDARD
	39R506	39R507	39R508		
	4 - 6 MM	6 - 7.5 MM	7.5 - 9 MM		
41		•		7.5	GC0307
42		•		7.5	GC0307
45			•	3	GC0303
46		•		3	GC0303
47	•			3	GC0303

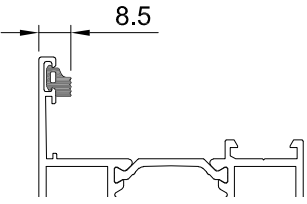
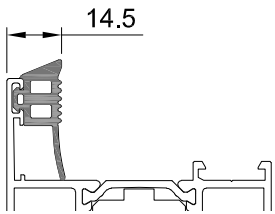
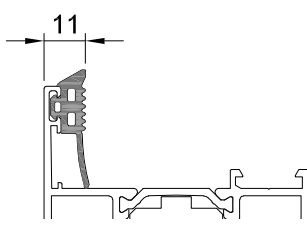
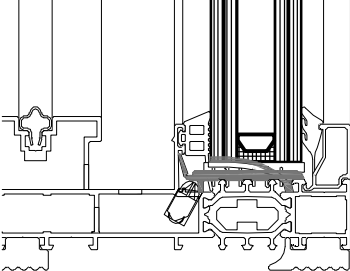

TUBOLARE						
L [mm]	CLASSICO	[dm ² / m]	[dm ² / m]			
3	GC0303	9.11	2.51			
7.5	GC0307	11.40	2.96			
10	GC2310	8.99	3.21			
12.5	GC2312	9.13	3.47			
15	GC2315	9.29	3.72			
17.5	GC2317	9.53	3.97			
20	GC2320	9.86	4.22			
22.5	GC2322	10.26	4.46			
25	GC2325	10.68	4.72			
27.5	GC2327	11.16	4.96			
30	GC2330	11.53	5.21			

	<p>210-003</p>		
	<p>RU0002</p>		
	<p>RU0004</p>		<p>210-003 RU0002 RU0004</p>
<p>🔑 E.3.1</p>		<p>🔑 E.3.1</p>	

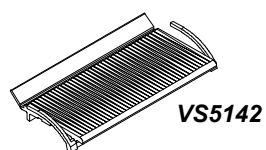
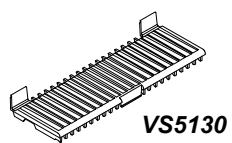

Accessori

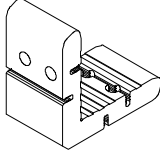

SQUADRETTE - SQUADRETTE CON SPINE CONICHE

DISEGNO	CODICE	 H x B (MM)	PROFILATO	Da ordinare a parte
	HV2W11	14 x 42.1	C9K120 -	2 x 71C011

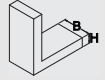
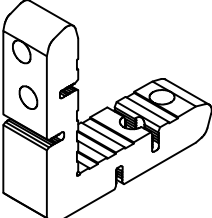
DISEGNO	CODICE	 H x B (MM)	PROFILATO	Da ordinare a parte
	HV2H06	14 x 19.6	C9K010 -	2 x 71C011

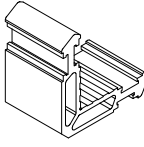
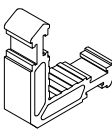
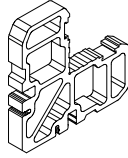

SQUADRETTE - SQUADRETTE CON ECCENTRICO

DISEGNO	CODICE	 H x B (MM)	PROFILATO	Da ordinare a parte
	HV0G03	14.5 x 42	C9K010 - - - - C9K120 -	4 x 778-500
	HV0H01	14.2 x 19.6	C9K010 -	2 x 778-500
	HV3H26	44.5 x 13.2	C9V001 - - - - C9V051 -	2 x 778-500 2 x 71C011

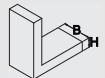
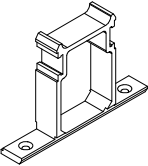
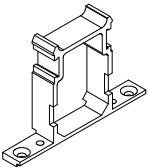



DISEGNO	CODICE	 H x B (MM)	PROFILATO	Da ordinare a parte
	TS3M03	44.1 x 15.8	C9K010 -	-
	TS3M04	44.1 x 15.8	C9K010 -	-

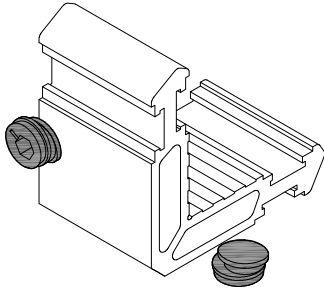
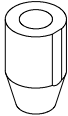
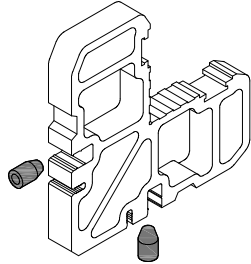

SQUADRETTE - CON SPINE

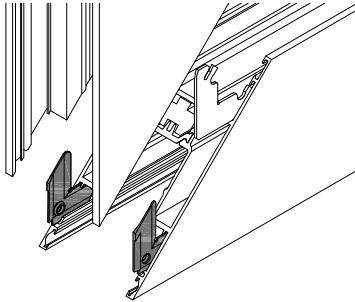

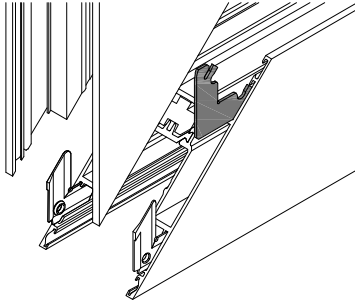

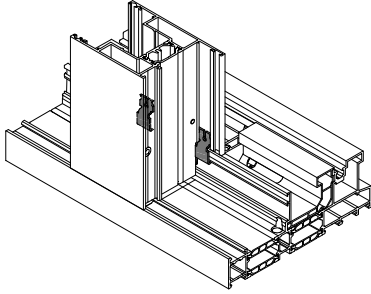

DISEGNO	CODICE	(MM)	DESCRIZIONE	APPLICAZIONE
	778-500		Eccentrico in zama	
	71C011		Spina conica in zama Ø8 x 13.5 mm	

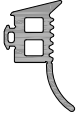
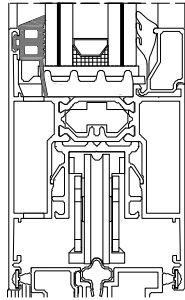

SQUADRETTE - SQUADRETTE DI ALLINEAMENTO

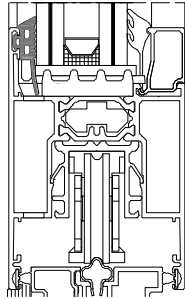
DISEGNO	CODICE	(MM)	DESCRIZIONE	APPLICAZIONE
	HV4K00		Squadretta allineamento in acciaio inossidabile	
	HV4K01		Squadretta allineamento in acciaio inossidabile	
	TS9Z05		Cavallotti allineamento trasversi in acciaio inossidabile	

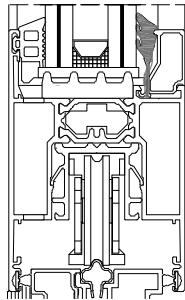

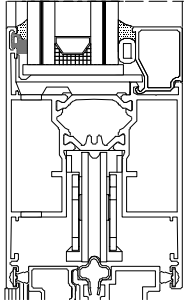
GUARNIZIONI - FINESTRE

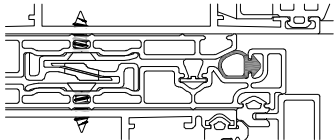

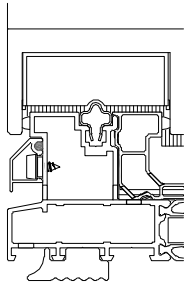

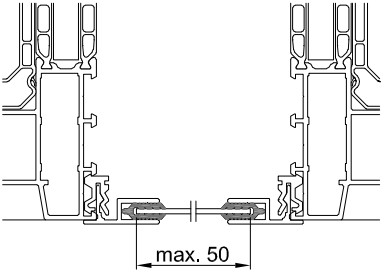
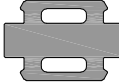
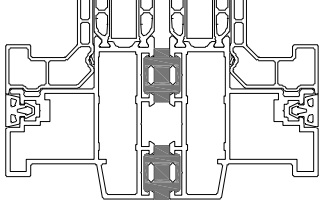

DISEGNO	CODICE	(MM)	DESCRIZIONE	APPLICAZIONE
	RU0002		Guarnizione esterna per vetratura in EPDM nero, spessore 10 mm	
	RU0004		Guarnizione esterna per vetratura in EPDM nero, spessore 6.5 mm	
	39R506	4 - 6 Marcatura blu	Guarnizione interna per vetratura in EPDM nero	
	39R507	6 - 7.5 Marcatura verde		
	39R508	7.5 - 9 Marcatura bianca		
	210-003		Guarnizione esterna per vetratura in EPDM nero	

DISEGNO	CODICE	(MM)	DESCRIZIONE	APPLICAZIONE
	RU9095		EPDM sealing gasket corner post, in black	
	213-006		Guarnizione di sigillatura in EPDM nero, Ø4 mm	

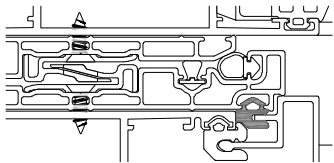

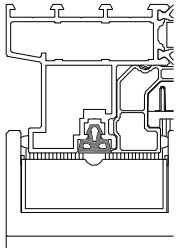
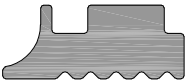
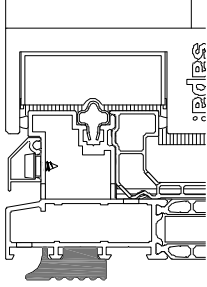

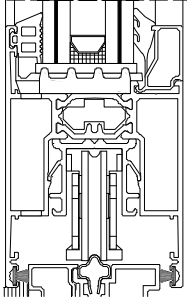
GUARNIZIONI - VARIE

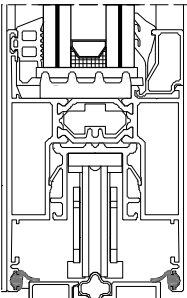
DISEGNO	CODICE	(MM)	DESCRIZIONE	APPLICAZIONE
	71R200		Guarnizione in EPDM giunti dilatazione disponibile in nero	
	RU9022		Guarnizione in EPDM accoppiamento telai disponibile in nero	

DISEGNO	CODICE	(MM)	DESCRIZIONE	APPLICAZIONE
	RU9703		Guarnizione di posizionamento su labirinto in EPDM nero	
	RU9704		Guarnizione copri-canale in EPDM nero	
	RU9079		Guarnizione soglia in EPDM nero	
	KU6004		Guarnizione tenuta ante in Q-lon nero	
	RU0099		Guarnizione di battuta in EPDM nero	

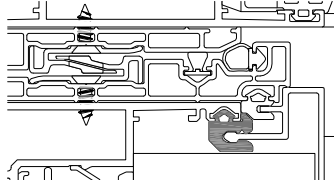

GUARNIZIONI - GUARNIZIONI DI SISTEMA

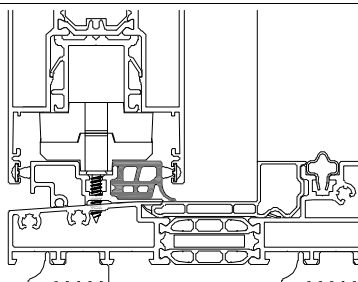
DISEGNO	CODICE	(MM)	DESCRIZIONE	APPLICAZIONE
	RU9094		Guarnizione tenuta ante in EPDM nero	
	RU9131		Guarnizione tenuta ante soglia ribassata	







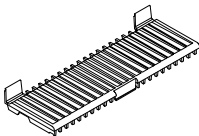
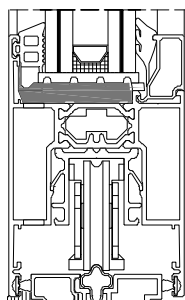
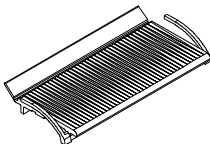
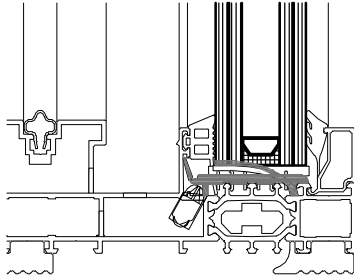

ACCESSORI

GUARNIZIONI - GUARNIZIONI DI SISTEMA

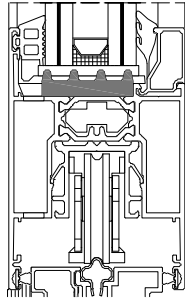

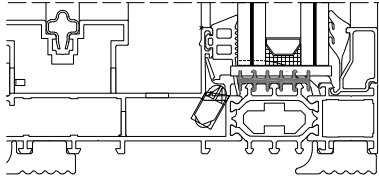

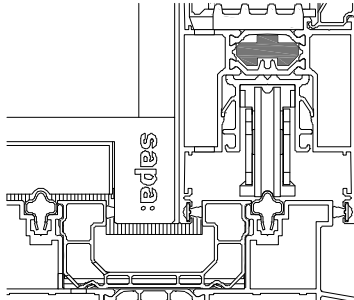

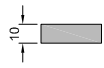
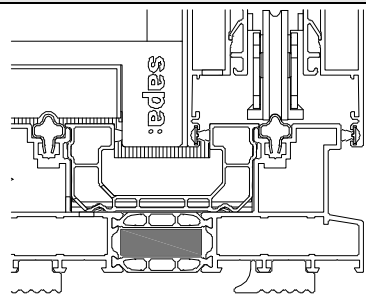
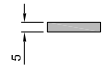
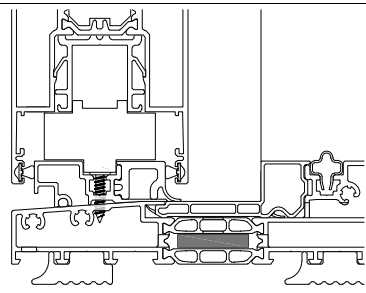
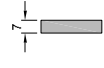
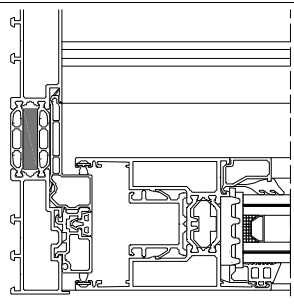
ACCESSORI - FINESTRE

DISEGNO	CODICE	(MM)	DESCRIZIONE	APPLICAZIONE
	VS51' \$		Supporto vetratura, nero	
	VS5142		Supporto vetro per vetratura fissa, rosso	
	KU5001		Profilo PE foam con striscia adesiva per profilato anta	
	KU5004		Profilo di isolamento in TPE foam per telai	
	BT6000		Isolatore termico in PE foam, in nero	

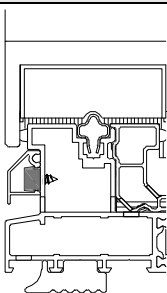
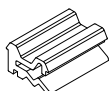
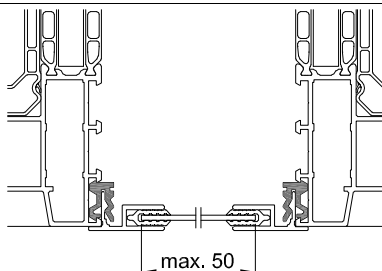
DISEGNO	CODICE	(MM)	DESCRIZIONE	APPLICAZIONE
	BT6006		Isolatore termico in PE foam, in nero	
	BT6017		Isolatore termico in PE foam, in nero	
	BT6019		Isolatore termico in PE foam, in nero	

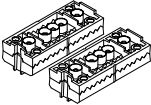
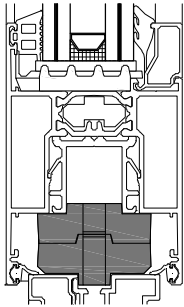
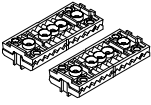
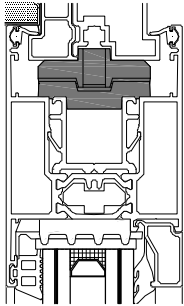
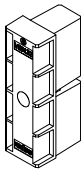
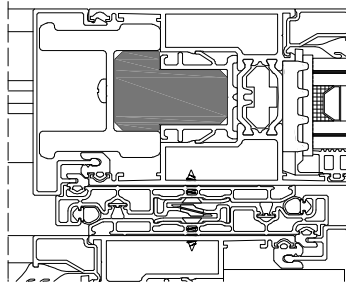

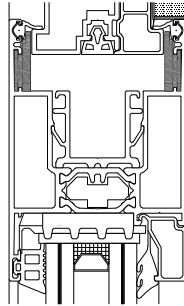

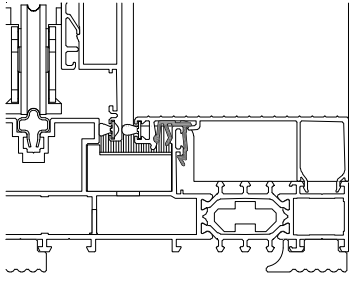



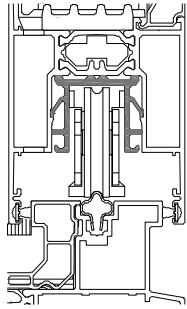
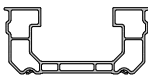
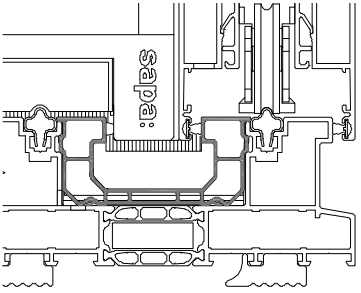

DISEGNO	CODICE	(MM)	DESCRIZIONE	APPLICAZIONE
	CO2279		Clips in alluminio per profilati di finitura	
	71P003		Clips in nylon per profilati di finitura disponibile in nero	

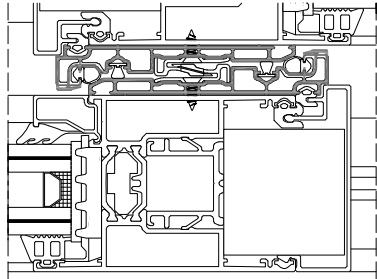
DISEGNO	CODICE	(MM)	DESCRIZIONE	APPLICAZIONE
	VS5128		Supporto inferiore per rendere fissa l'anta alzante-scorrevole	
	VS5129		Supporto superiore per rendere fissa l'anta alzante-scorrevole	
	VS5132		Supporto rinforzo	
	VS5131		Guida anti scarrucolamento	
	215-008		Profilo di isolamento	

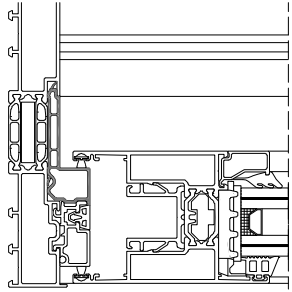

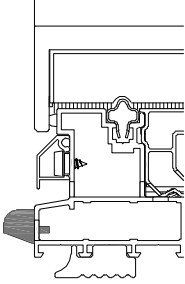
ACCESSORI - ACCESSORI DI SISTEMA

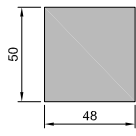
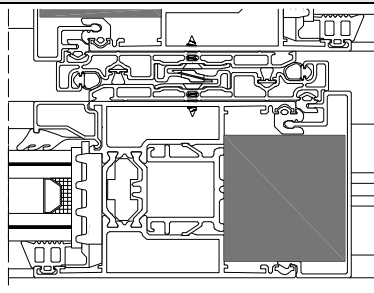
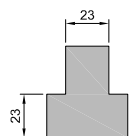
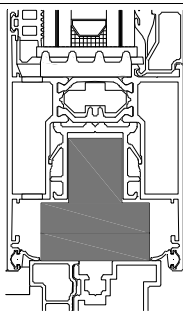
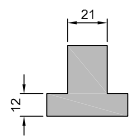
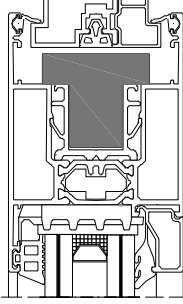

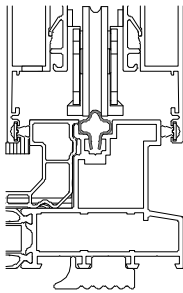

DISEGNO	CODICE	(MM)	DESCRIZIONE	APPLICAZIONE
	KU2027		Profilo di isolamento ferramenta	
	KU2028		Profilo di isolamento	
	KU2029		Labirinto centrale isolato	
	KU2035		Profilo di isolamento	
	D4074009		Cappetta di drenaggio	

DISEGNO	CODICE	(MM)	DESCRIZIONE	APPLICAZIONE
	BT6013		Isolante termico in PE foam	
	BT6015		Isolante termico in PE foam	
	BT6026		Isolante termico in PE foam	
	CO1103		Guida in acciaio	

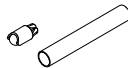
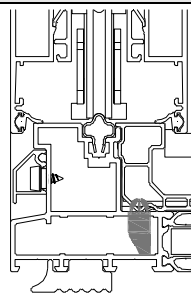
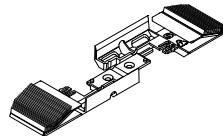
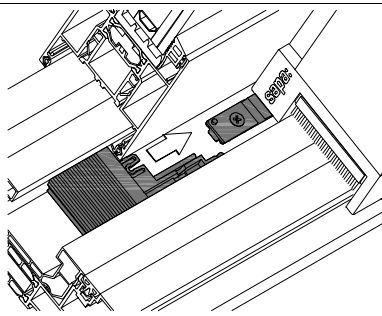
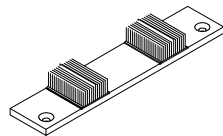
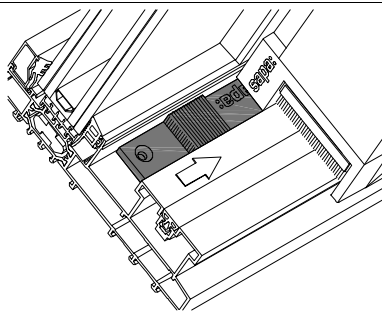
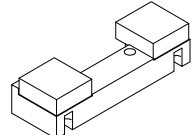
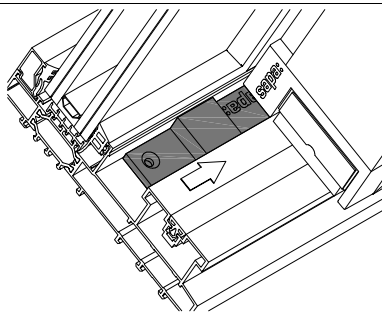
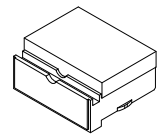
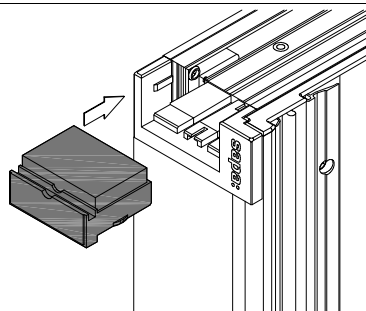

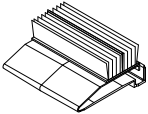
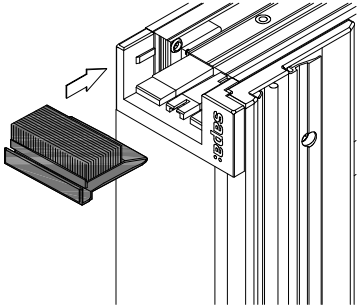
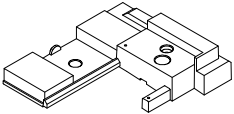
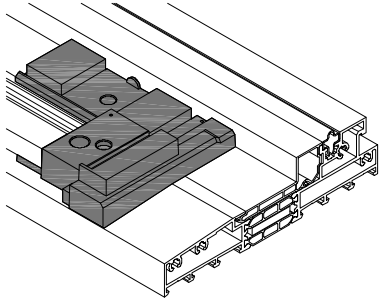
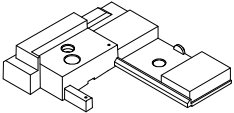
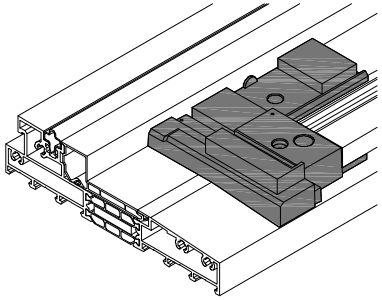

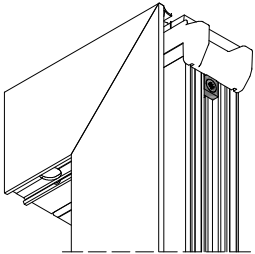

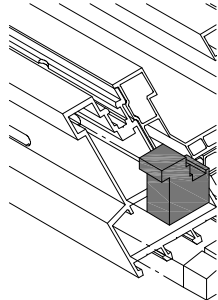
ACCESSORI - ACCESSORI DI SISTEMA

DISEGNO	CODICE	(MM)	DESCRIZIONE	APPLICAZIONE
	VS0107		Cappetta di drenaggio con pallina	
	CO1111		Tappo di tenuta centrale superiore telaio esterno - alzante-scorrevole	
	CO1114		Tappo riempimento centrale 1-binario	
	CO1116		Tappo riempimento centrale 1-binario	
	CO1107		Tappo tenuta centrale inferiore	

DISEGNO	CODICE	(MM)	DESCRIZIONE	APPLICAZIONE
	CO1110		Tappo tenuta centrale profilo labirinto centrale alzante-scorrevole	
	CO1136		Tappo tenuta soglia ribassata alzante-scorrevole - sinistro	
	CO1137		Tappo tenuta soglia ribassata alzante-scorrevole - destro	
	CO1214		Clip per tappo di tenuta	
	VS9950		Tappo di tenuta	

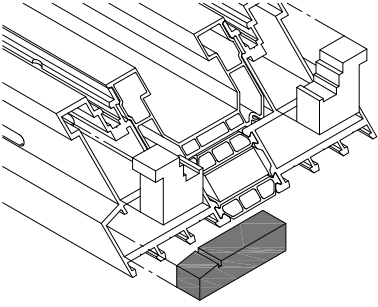
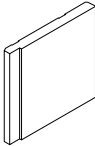
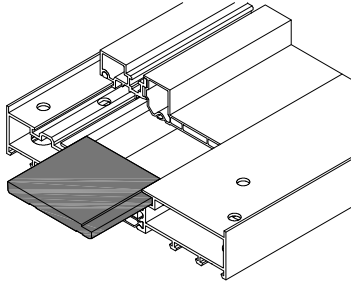

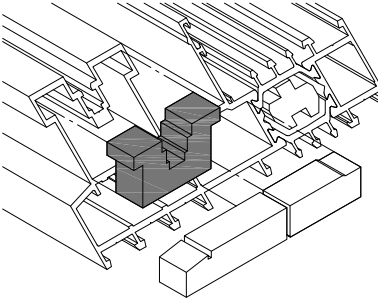

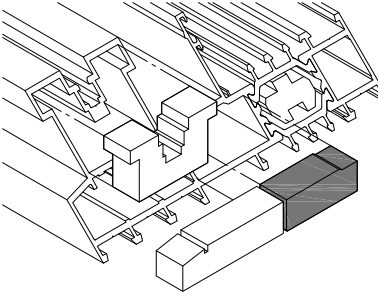
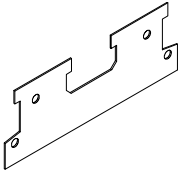
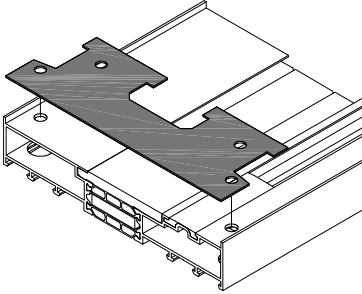

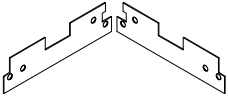
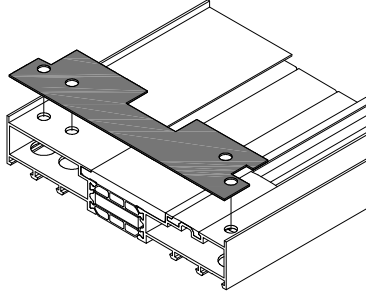
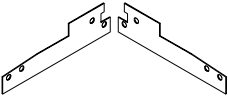
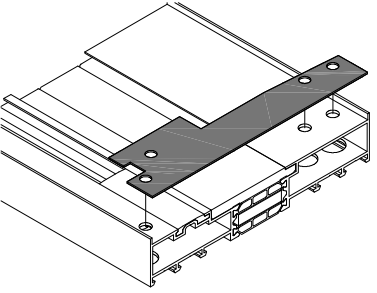
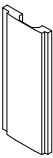
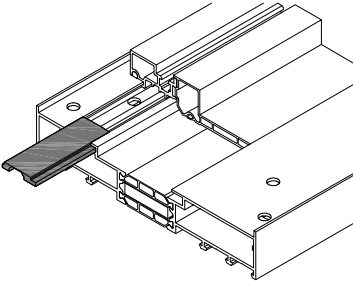
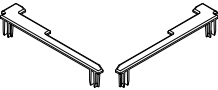
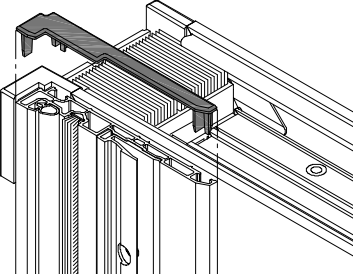
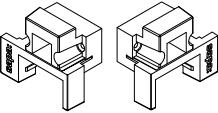
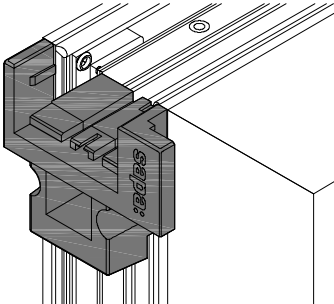
ACCESSORI - ACCESSORI DI SISTEMA

DISEGNO	CODICE	(MM)	DESCRIZIONE	APPLICAZIONE
	VS9951		Tappo di tenuta	
	VS9957		Tappo di tenuta per tagli a 90°	
	VS9958		Tappo di tenuta e drenaggio	
	VS9959		Tappo di tenuta e drenaggio	
	VS9956		Tappo di sigillatura sagomato tagli a 90° soglia	

DISEGNO	CODICE	(MM)	DESCRIZIONE	APPLICAZIONE
	VS9970		Tappo di tenuta basso tagli a 90°	
	VS9971		Tappo di tenuta basso tagli a 90°	
	CO0132		Tappo riempimento tagli a 90°	
	VS9148		Tappo terminale	
	VS9149		Tappo terminale	

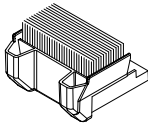
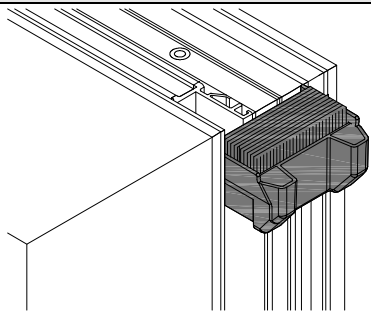
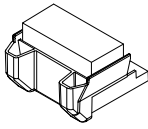
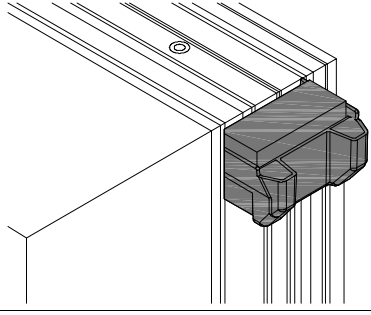

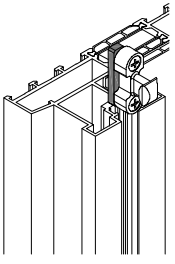
ACCESSORI - ACCESSORI DI SISTEMA

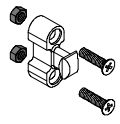
DISEGNO	CODICE	(MM)	DESCRIZIONE	APPLICAZIONE
	CO1118		Tappo di tenuta per C9C002 - Alzante-scorrevole - superiore	
	CO1125		Tappo di tenuta per C9C002 - Alzante-scorrevole - inferiore	
	CO2211		Spessore	
	SCG641		Dado - M5 DIN 934	

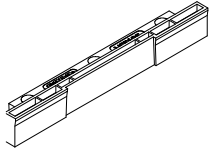
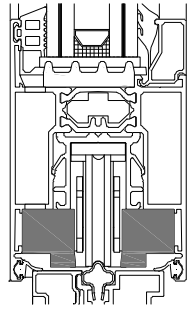
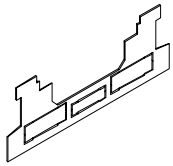
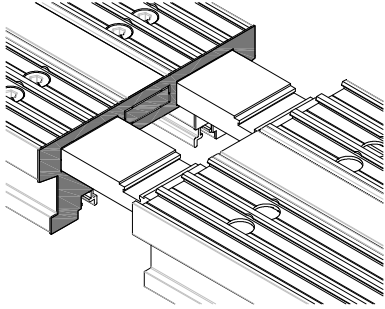
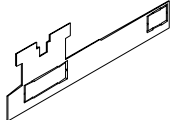
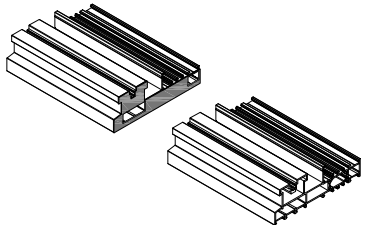
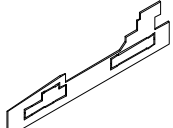
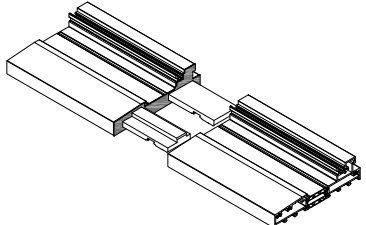
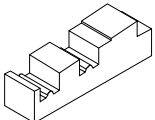
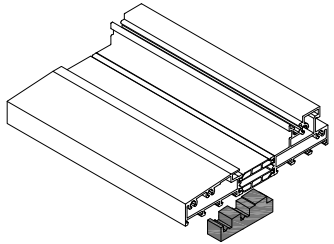
DISEGNO	CODICE	(MM)	DESCRIZIONE	APPLICAZIONE
	VS5135		Blocco centrale alzante-scorrevole	
	VS8002		Tappo di tenuta per C9K120	
	VS8004		Tappo di tenuta per C9K010	
	VS8005		Tappo di tenuta per C9K100	
	VS8006		Tappo di tenuta per C9K100	

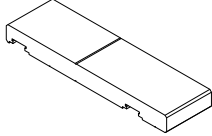
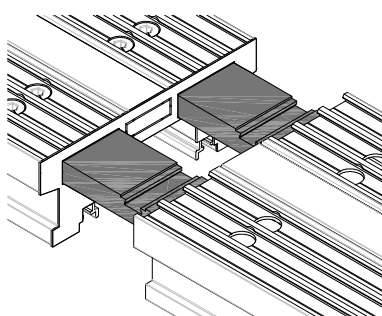
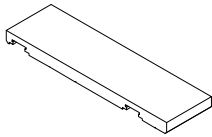
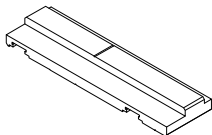
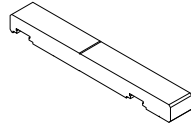

ACCESSORI - ACCESSORI DI SISTEMA

DISEGNO	CODICE	(MM)	DESCRIZIONE	APPLICAZIONE
	CO2251		connessione per C9K120/ C9K010	
	CO2252		connessione per C9K100	
	CO2253		connessione per C9K100	
	CO2254		connessione per C9K010	



ACCESSORI

ACCESSORI - ACCESSORI DI SISTEMA



	
DIN 916 - ST.ST. - A2	
702-939	M5x5

	
DIN 7981C - ST.ST. - A2	
787-570	Ø6,3x32

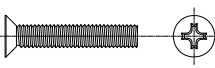
	
DIN 965 - ST.ST. - A2	
80H520	M5x20

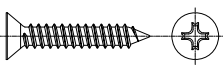
	
DIN 7982C - ST.ST. - A2	
82L416	Ø4,2x16









ACCESSORI

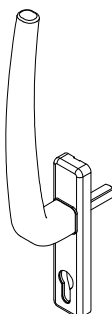

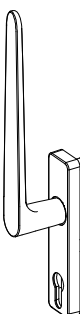
VITI

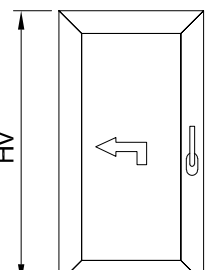
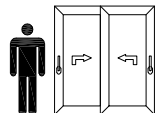
Selezione ferramenta

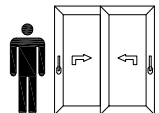
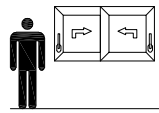
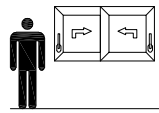
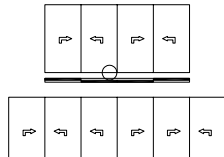

  F.1.2		  F.1.3	
 Hv		Hv	
		1904 - 2803	F.1.5
		2804 - 3403	F.1.6
		1303 - 1903	F.1.4
 +		F.1.7	

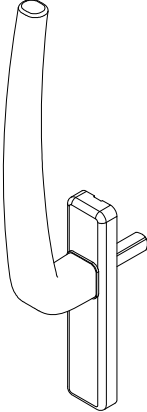
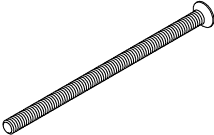

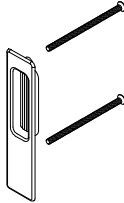
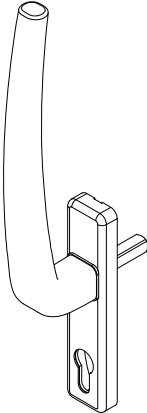
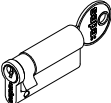
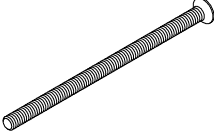
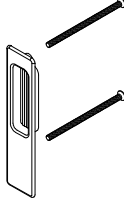
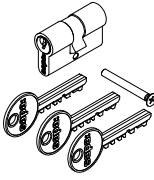
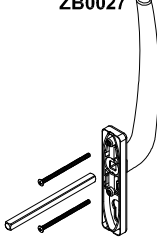
MANIGLIE STANDARD

MANIGLIA INTERNA	CILINDRO	MANIGLIA ESTERNA	CHIUSURA SUPPL.
<p>ZB0024</p> 	<p>-</p>	<p>SCE565 x2 (M5x65 DIN 965)</p> 	<p>(Ø5x60)</p> 
		<p>or</p> <p>ZB0028</p> 	
or			
<p>ZB0025</p> 	<p>CYL102</p> 	<p>SCE565 x2 (M5x65 DIN 965)</p> 	<p>-</p>
		<p>or</p> <p>ZB0028</p> 	
	<p>CYL318</p> 	<p>ZB0027</p> 	

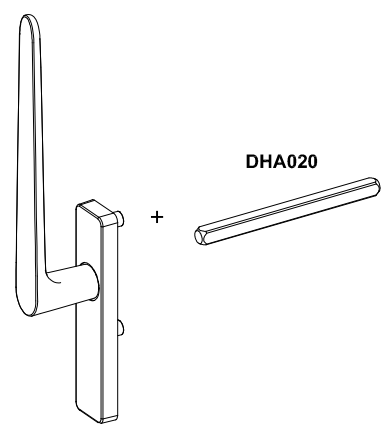
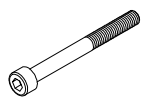
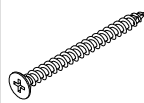
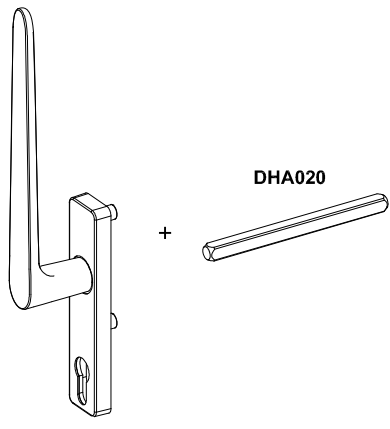
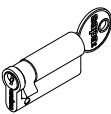
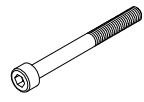
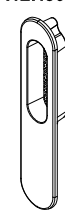
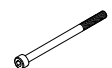
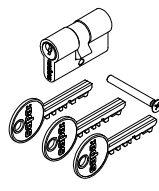
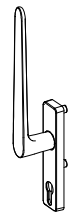

ALZANTE-SCORREVOLE

MANIGLIE S-LINE (HARMONY)

MANIGLIA INTERNA	CILINDRO	MANIGLIA ESTERNA	CHIUSURA SUPPL.
HLH301 	-	SCL550 x2 (M5x50 DIN 912) 	(Ø5x60) 
		or	
or			
HLH302 	CYL102 	SCL550 x2 (M5x50 DIN 912) 	-
		or	
		HLH304  + SCL575 x2 (M5x75 DIN 912) 	
	CYL318 	HLH302  + SCL575 x2 (M5x75 DIN 912)  + SCG641 x2 (M5 DIN934) 	

 C160-DIAG-062

Hv = 1303 - 1903

	<p>ZB0048</p> <div style="border: 1px solid black; padding: 5px; width: fit-content;"> Hv + Lv ≤ 5258 ZB0049 </div> <div style="border: 1px solid black; padding: 5px; width: fit-content;"> Hv + Lv > 5258 ZB0050 </div>																				
+																					
<p>ZB0033</p>	<div style="border: 1px solid black; padding: 5px; width: fit-content;"> = 101 - 200 kg ZB0053 </div> <div style="border: 1px solid black; padding: 5px; width: fit-content;"> = 201 - 400 kg ZB0054 </div>	<table border="1"> <tr> <td data-bbox="853 694 1125 616"> <p>(Ø5x40)</p> </td> <td data-bbox="1125 694 1252 616"></td> <td data-bbox="1252 694 1396 616" style="text-align: center;">x5</td> </tr> <tr> <td data-bbox="853 616 1125 817"> <p>(Ø5x60)</p> </td> <td data-bbox="1125 616 1252 817" style="text-align: center;">x5</td> <td data-bbox="1252 616 1396 817" style="text-align: center;">x6</td> </tr> <tr> <td data-bbox="853 817 1125 952"> <p>80H520 (M5x20 DIN965)</p> </td> <td data-bbox="1125 817 1252 952" style="text-align: center;">x4</td> <td data-bbox="1252 817 1396 952" style="text-align: center;">x6</td> </tr> <tr> <td data-bbox="853 952 1125 1041"> <p>SCG641 (M5 DIN934)</p> </td> <td data-bbox="1125 952 1252 1041" style="text-align: center;">x4</td> <td data-bbox="1252 952 1396 1041"></td> </tr> <tr> <td data-bbox="853 1041 1125 1232"> <p>CO2211</p> </td> <td data-bbox="1125 1041 1252 1232"></td> <td data-bbox="1252 1041 1396 1232" style="text-align: center;">x3</td> </tr> <tr> <td data-bbox="853 1232 1125 1433"> <p>SF3925</p> </td> <td data-bbox="1125 1232 1252 1433"></td> <td data-bbox="1252 1232 1396 1433" style="text-align: center;">x1</td> </tr> </table>		<p>(Ø5x40)</p>		x5	<p>(Ø5x60)</p>	x5	x6	<p>80H520 (M5x20 DIN965)</p>	x4	x6	<p>SCG641 (M5 DIN934)</p>	x4		<p>CO2211</p>		x3	<p>SF3925</p>		x1
<p>(Ø5x40)</p>		x5																			
<p>(Ø5x60)</p>	x5	x6																			
<p>80H520 (M5x20 DIN965)</p>	x4	x6																			
<p>SCG641 (M5 DIN934)</p>	x4																				
<p>CO2211</p>		x3																			
<p>SF3925</p>		x1																			
+																					
+																					
<p>ZB0040</p> <p>(Ø4.2x45) x2 (DIN7982C-H)</p> <p>VS5135 x4 (Ø4.8x22) x12 (DIN7504N-Z) (Ø5x40) x5</p>																					
+																					
<div style="border: 1px solid black; padding: 5px;"> <p>SV0032 = 301 - 400 kg</p> </div> <div style="border: 1px solid black; padding: 5px; width: fit-content; margin-top: 10px;"> <p>VS5135 x4 (Ø4.8x22) x12 (DIN7504N-Z) (Ø5x40) x4</p> </div> <div style="border: 1px solid black; padding: 5px; margin-top: 10px;"> <p>Lv = 720 - 1500 ZB0029 ≤ 300 kg</p> <p>Lv = 1501 - 2000 ZB0030</p> <p>Lv = 2001 - 2500 ZB0031</p> <p>Lv = 2501 - 3250 ZB0032</p> </div> <div style="border: 1px solid black; padding: 5px; margin-top: 10px; width: fit-content;"> <p> = 301 - 400 kg</p> <p>Lv = 1316 - 2096 ZB0029</p> <p>Lv = 2097 - 2596 ZB0030</p> <p>Lv = 2597 - 3096 ZB0031</p> <p>Lv = 3097 - 3846 ZB0032</p> </div>																					



ALZANTE-SCORREVOLE

Hv = 1904 - 2803

	<p>ZB0048</p> <div style="border: 1px solid black; padding: 2px; width: fit-content;"> Hv + Lv ≤ 5258 ZB0049 </div> <div style="border: 1px solid black; padding: 2px; width: fit-content;"> Hv + Lv > 5258 ZB0050 </div>		
+		<p>(Ø5x40)</p> <p style="text-align: right;">x5</p>	
<div style="border: 1px solid black; padding: 2px; width: fit-content;"> Hv = 1904 - 2203 ZB0034 </div> <div style="border: 1px solid black; padding: 2px; width: fit-content;"> Hv = 2204 - 2503 ZB0035 </div> <div style="border: 1px solid black; padding: 2px; width: fit-content;"> Hv = 2504 - 2803 ZB0036 </div>	<div style="border: 1px solid black; padding: 2px; width: fit-content;"> = 101 - 200 kg ZB0053 </div> <div style="border: 1px solid black; padding: 2px; width: fit-content;"> = 201 - 400 kg ZB0054 </div>	<p>(Ø5x60)</p> <p style="text-align: center;">x8</p>	<p style="text-align: center;">x9</p>
+		<p>80H520 (M5x20 DIN965)</p> <p style="text-align: center;">x4</p>	<p style="text-align: center;">x8</p>
+		<p>SCG641 (M5 DIN934)</p> <p style="text-align: center;">x4</p>	/
+		<p>CO2211</p>	<p style="text-align: center;">x4</p>
+		+	
<p>ZB0040</p> <p>(Ø4.2x45) x2 (DIN7982C-H)</p> <p>VS5135 x4</p> <p>(Ø4.8x22) x12 (DIN7504N-Z)</p> <p>(Ø5x40) x5</p>		+	<div style="border: 1px solid black; padding: 2px;"> Lv = 720 - 1500 ZB0029 </div> <div style="border: 1px solid black; padding: 2px;"> Lv = 1501 - 2000 ZB0030 </div> <div style="border: 1px solid black; padding: 2px;"> Lv = 2001 - 2500 ZB0031 </div> <div style="border: 1px solid black; padding: 2px;"> Lv = 2501 - 3250 ZB0032 </div>
+		+	
<p>SV0032</p> <div style="border: 1px solid black; padding: 2px; width: fit-content;"> = 301 - 400 kg </div> <p>VS5135 x4</p> <p>(Ø4.8x22) x12 (DIN7504N-Z)</p> <p>(Ø5x40) x4</p>		<div style="border: 1px solid black; padding: 2px;"> = 301 - 400 kg </div> <div style="border: 1px solid black; padding: 2px;"> Lv = 1316 - 2096 ZB0029 </div> <div style="border: 1px solid black; padding: 2px;"> Lv = 2097 - 2596 ZB0030 </div> <div style="border: 1px solid black; padding: 2px;"> Lv = 2597 - 3096 ZB0031 </div> <div style="border: 1px solid black; padding: 2px;"> Lv = 3097 - 3846 ZB0032 </div>	

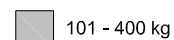
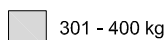



Hv = 2804 - 3403

	<p>ZB0048</p> <div style="border: 1px solid black; padding: 5px; width: fit-content;"> <p>Hv + Lv ≤ 5258 ZB0049</p> <p>Hv + Lv > 5258 ZB0050</p> </div>																			
+																				
<div style="border: 1px solid black; padding: 5px; width: fit-content;"> <p>Hv = 2804 - 3103 ZB0035</p> <p>Hv = 3104 - 3403 ZB0036</p> </div>	<p>ZB0046</p> <p>ZB0045</p>	<div style="border: 1px solid black; padding: 5px; width: fit-content;"> <p>= 101 - 200 kg ZB0053</p> <p>= 201 - 400 kg ZB0054</p> </div>																		
+																				
	<p>ZB0040</p> <p>(Ø4.2x45) x2 (DIN7982C-H)</p> <p>VS5135 x4</p> <p>(Ø4.8x22) x12 (DIN7504N-Z)</p> <p>(Ø5x40) x5</p>																			
+																				
<p>SV0032</p>	<div style="border: 1px solid black; padding: 5px; width: fit-content;"> <p>= 301 - 400 kg</p> </div> <p>VS5135 x4</p> <p>(Ø4.8x22) x12 (DIN7504N-Z)</p> <p>(Ø5x40) x4</p>																			
+																				
		<div style="display: flex; justify-content: space-around;"> </div> <table border="1" style="width: 100%; text-align: center;"> <tr> <td data-bbox="893 425 1125 616"> <p>(Ø5x40)</p> </td> <td data-bbox="1125 425 1252 616"></td> <td data-bbox="1252 425 1396 616"> <p>x5</p> </td> </tr> <tr> <td data-bbox="893 616 1125 817"> <p>(Ø5x60)</p> </td> <td data-bbox="1125 616 1252 817"> <p>x11</p> </td> <td data-bbox="1252 616 1396 817"> <p>x12</p> </td> </tr> <tr> <td data-bbox="893 817 1125 952"> <p>80H520 (M5x20 DIN965)</p> </td> <td data-bbox="1125 817 1252 952"> <p>x6</p> </td> <td data-bbox="1252 817 1396 952"> <p>x10</p> </td> </tr> <tr> <td data-bbox="893 952 1125 1041"> <p>SCG641 (M5 DIN934)</p> </td> <td data-bbox="1125 952 1252 1041"> <p>x6</p> </td> <td data-bbox="1252 952 1396 1041"></td> </tr> <tr> <td data-bbox="893 1041 1125 1232"> <p>CO2211</p> </td> <td data-bbox="1125 1041 1252 1232"></td> <td data-bbox="1252 1041 1396 1232"> <p>x5</p> </td> </tr> <tr> <td data-bbox="893 1232 1125 1433"> <p>SF3925</p> </td> <td data-bbox="1125 1232 1252 1433"> <p>x1</p> </td> <td data-bbox="1252 1232 1396 1433"> <p>x3</p> </td> </tr> </table>	<p>(Ø5x40)</p>		<p>x5</p>	<p>(Ø5x60)</p>	<p>x11</p>	<p>x12</p>	<p>80H520 (M5x20 DIN965)</p>	<p>x6</p>	<p>x10</p>	<p>SCG641 (M5 DIN934)</p>	<p>x6</p>		<p>CO2211</p>		<p>x5</p>	<p>SF3925</p>	<p>x1</p>	<p>x3</p>
<p>(Ø5x40)</p>		<p>x5</p>																		
<p>(Ø5x60)</p>	<p>x11</p>	<p>x12</p>																		
<p>80H520 (M5x20 DIN965)</p>	<p>x6</p>	<p>x10</p>																		
<p>SCG641 (M5 DIN934)</p>	<p>x6</p>																			
<p>CO2211</p>		<p>x5</p>																		
<p>SF3925</p>	<p>x1</p>	<p>x3</p>																		
		+																		
		<div style="border: 1px solid black; padding: 5px; width: fit-content;"> <p>Lv = 720 - 1500 ZB0029</p> <p>Lv = 1501 - 2000 ZB0030</p> <p>Lv = 2001 - 2500 ZB0031</p> <p>Lv = 2501 - 3250 ZB0032</p> </div> <div style="border: 1px solid black; padding: 5px; width: fit-content; margin-top: 10px;"> <p>≤ 300 kg</p> </div> <div style="border: 1px solid black; padding: 5px; width: fit-content; margin-top: 10px;"> <p>= 301 - 400 kg</p> </div> <div style="border: 1px solid black; padding: 5px; width: fit-content; margin-top: 10px;"> <p>Lv = 1316 - 2096 ZB0029</p> <p>Lv = 2097 - 2596 ZB0030</p> <p>Lv = 2597 - 3096 ZB0031</p> <p>Lv = 3097 - 3846 ZB0032</p> </div>																		



ALZANTE-SCORREVOLE - SCHEMA 4 ANTE

PEZZI SUPPLEMENTARI

DISEGNO	CODICE	DESCRIZIONE
	ZB0038	Punto di chiusura centrale nel caso di ante schema 4 ante, connessione a ZB0040
	82L538	Viti autofilettanti Ø4.8x38 mm DIN 7982CHI



SELEZIONE FERRAMENTA

ALZANTE-SCORREVOLE - SCHEMA 4 ANTE







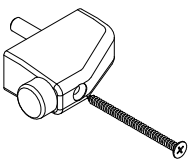
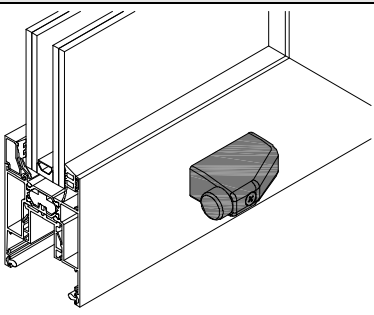
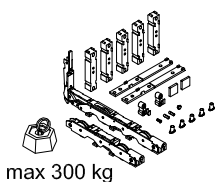
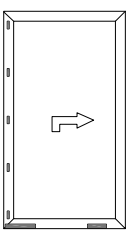
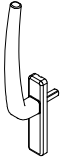
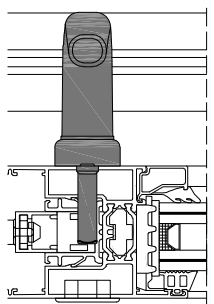
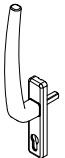
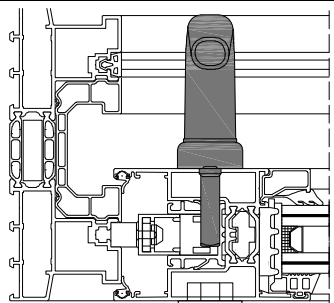
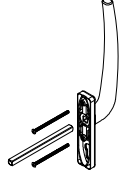
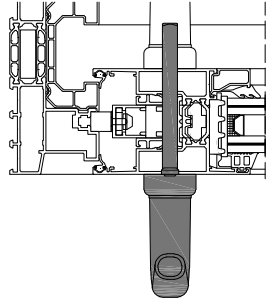

LISTA ARTICOLI FERRAMENTA



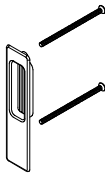
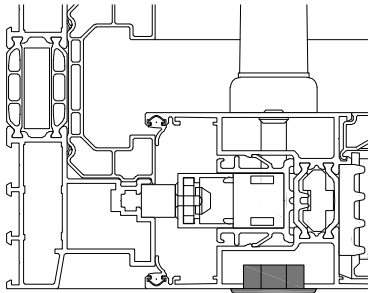

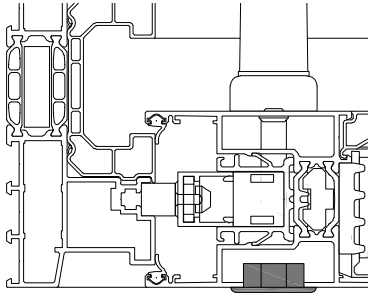
DISEGNO	CODICE	(MM)	DESCRIZIONE	APPLICAZIONE
	ZB0045		Blocchetto supporto ferramenta	
	CYL102		Mezzo cilindro alzante- scorrevole 60/50/10	
	CYL318		Cilindro alzante-scorrevole 100/50/50	
	SF3925		Parte di bloccaggio alzante- scorrevole	
	ZB0038		Set di bloccaggio	

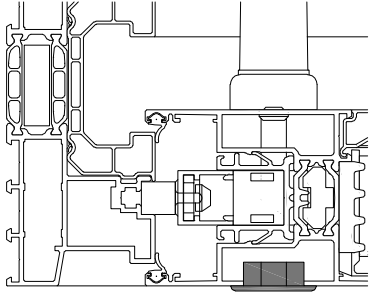
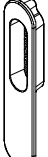
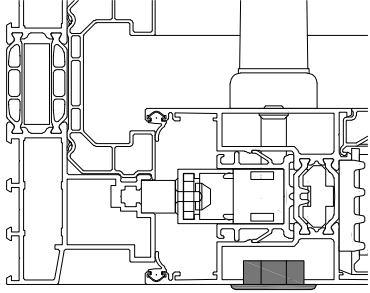
DISEGNO	CODICE	(MM)	DESCRIZIONE	APPLICAZIONE
	SV9002		Paracolpi	
 <p>max 300 kg</p>	ZB0040		Set base alzante-scorrevole	
	ZB0024		Maniglia interna alzante-scorrevole	
	ZB0025		Maniglia interna alzante-scorrevole per cilindro di chiusura	
	ZB0027		Maniglia esterna alzante-scorrevole per cilindro di chiusura	

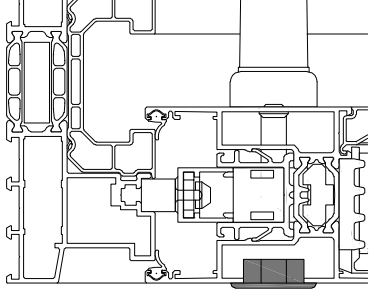

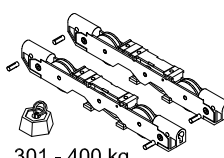
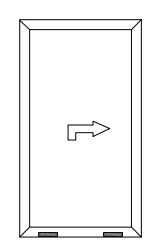
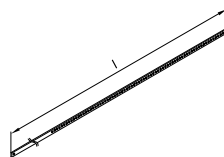
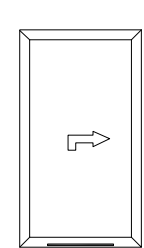
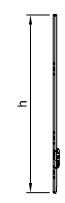
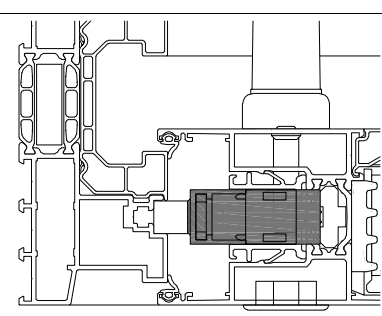
LISTA ARTICOLI FERRAMENTA

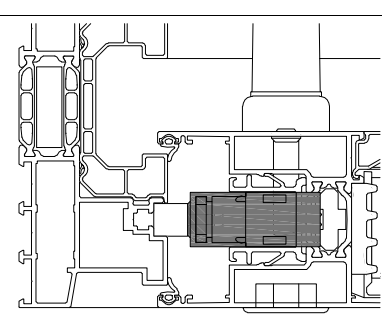
DISEGNO	CODICE	(MM)	DESCRIZIONE	APPLICAZIONE
	ZB0028		Maniglia integrata alzante-scorrevole	
	HLH301		Maniglia integrata alzante-scorrevole	
	HLH302		Maniglia interna S-Line alzante-scorrevole design: Harmony	
	HLH304		Maniglia interna/esterna S-Line alzante-scorrevole design: Harmony	
	DHA020		Maniglia S-Line alzante-scorrevole asta di connessione	

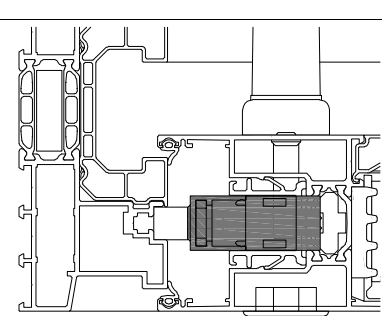
DISEGNO	CODICE	(MM)	DESCRIZIONE	APPLICAZIONE
 <p>301 - 400 kg</p>	SV0032		Carrello inferiore supplementare alzante-scorrevole 301-400 kg	
	ZB0029	860	Asta di connessione carrelli alzante-scorrevole	
	ZB0030	1360		
	ZB0031	1860		
	ZB0032	2600		
	ZB0033	1800	Serratura alzante-scorrevole	
	ZB0034	2100	Serratura alzante-scorrevole	
	ZB0035	2400	Serratura alzante-scorrevole	



LISTA ARTICOLI FERRAMENTA

DISEGNO	CODICE	(MM)	DESCRIZIONE	APPLICAZIONE
	ZB0036	2700	Serratura alzante-scorrevole	
	ZB0046	600	Estensione serratura alzante-scorrevole	



SELEZIONE FERRAMENTA

LISTA ARTICOLI FERRAMENTA

Attrezzature



LAVORAZIONE - D5110000

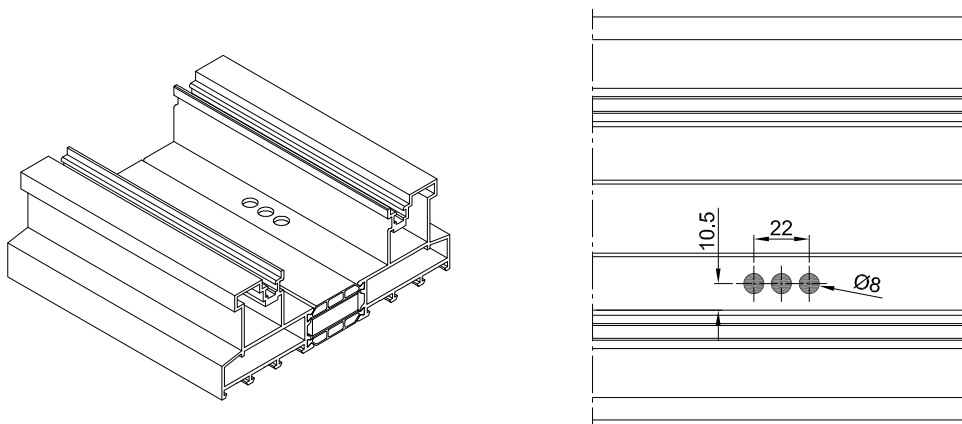
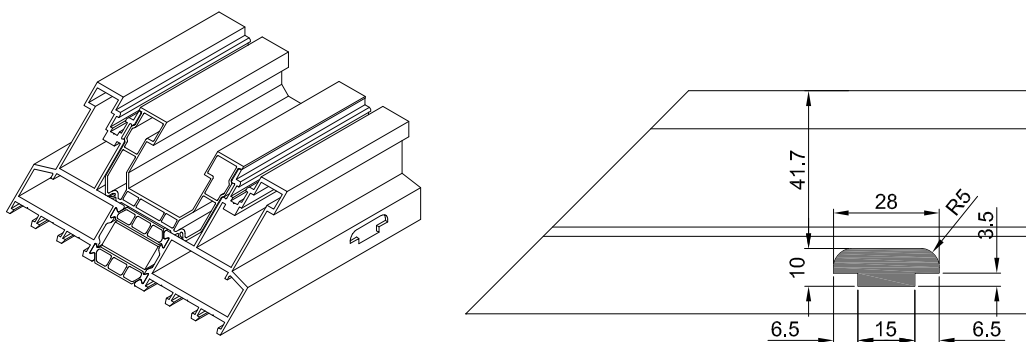
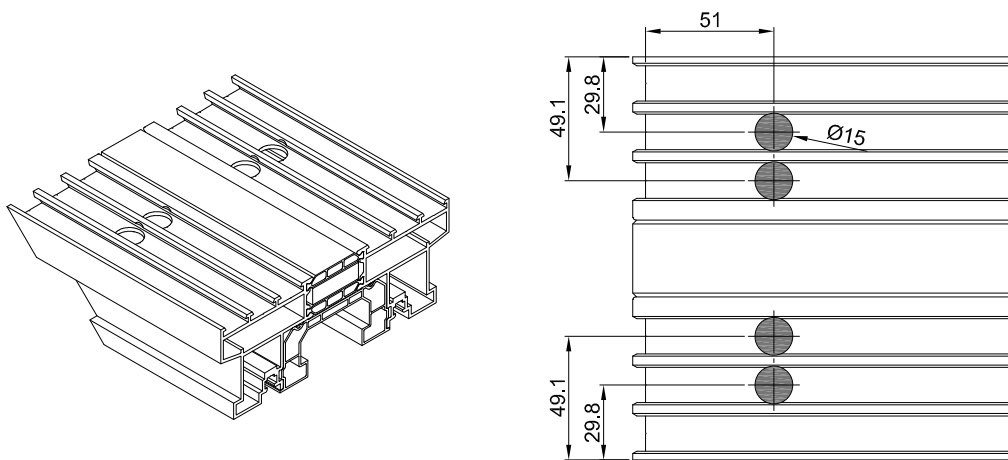

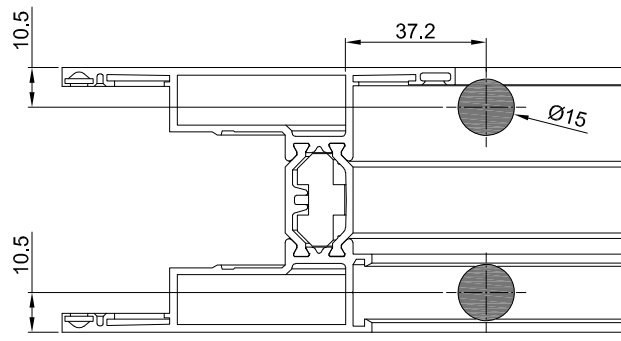
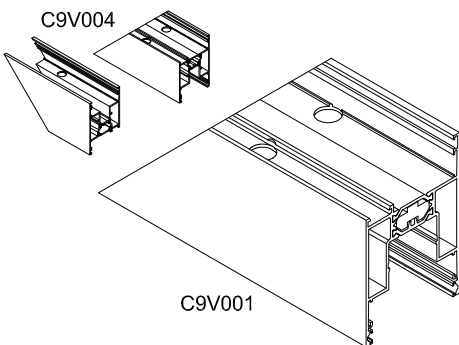
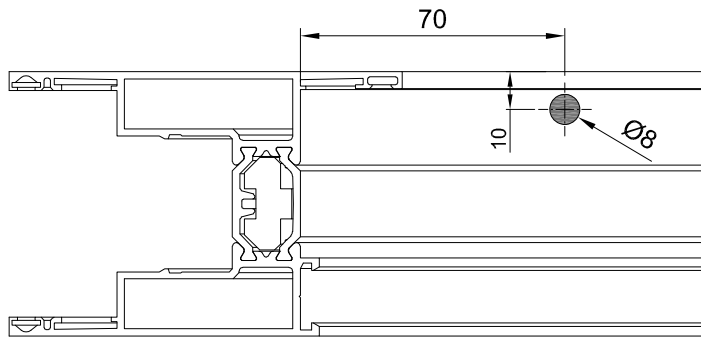
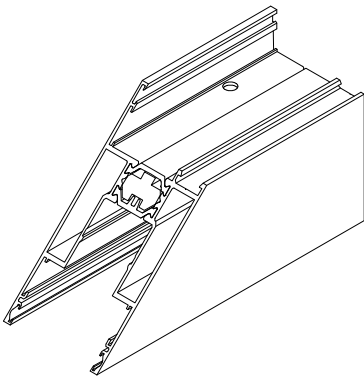
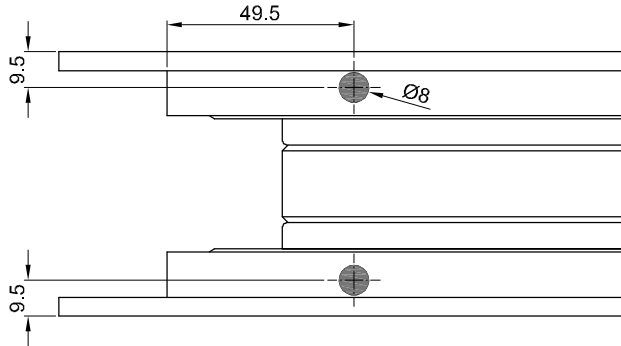
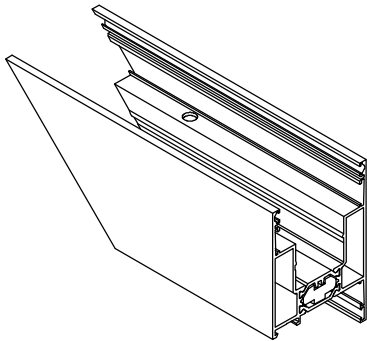



LAVORAZIONE - D5110000

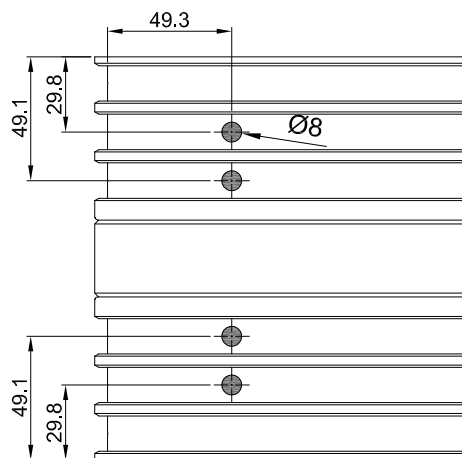
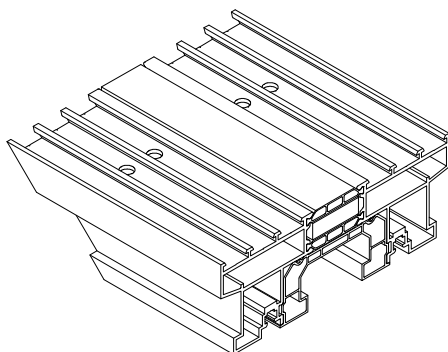



ATTREZZATURE

LAVORAZIONE - D5110000



DIME LAVORAZIONI - PANORAMICA

TG4116 G.2.2					
	G.2.3		G.2.4		G.2.4
	G.2.3		G.2.4		G.2.5
	G.2.3				

TG4119 G.2.6	
	G.2.6

Nota: tutte le lavorazioni indicate con le sottoelencate dime sono eseguibili con la punzonatrice D5110000.

TG4118 - TG4121 - TG4122

TG4116

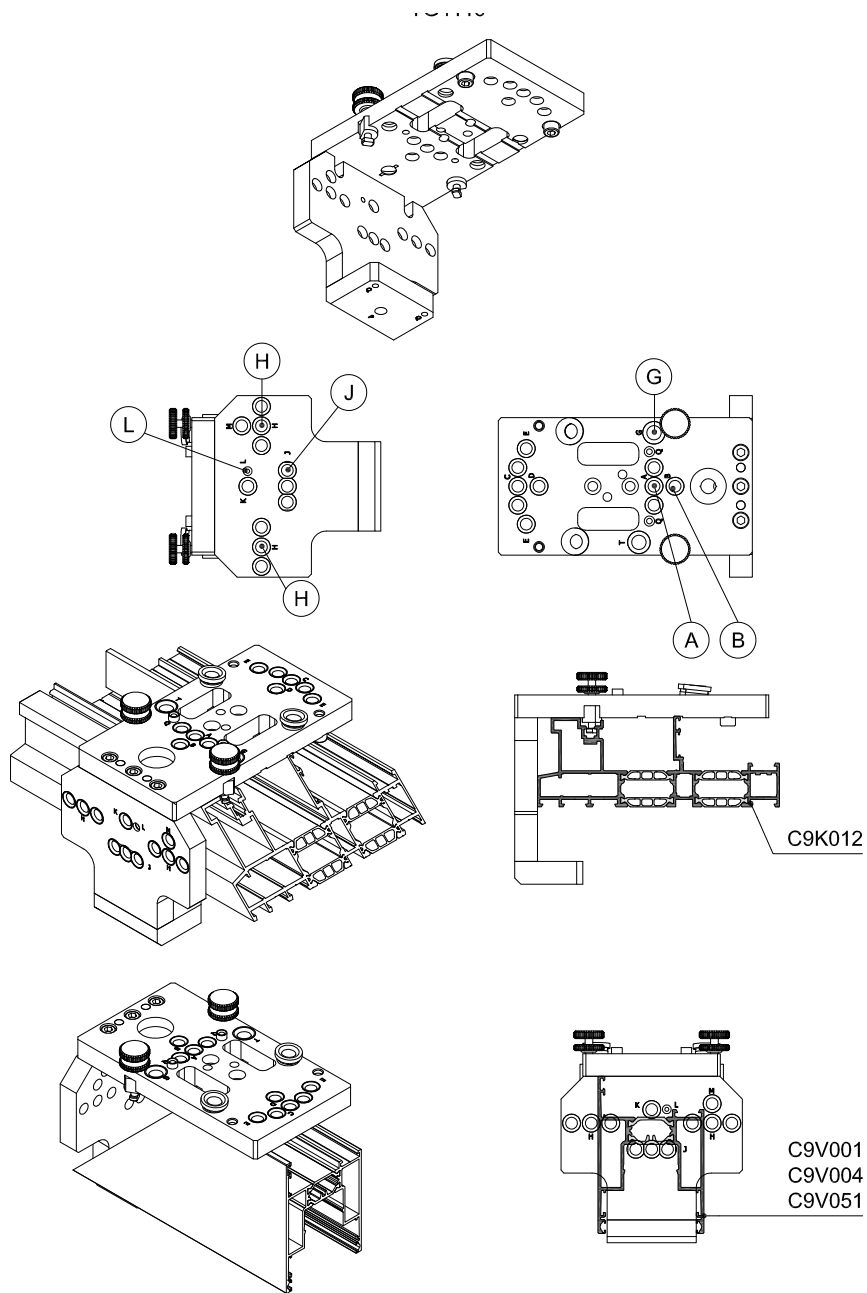

- A drenaggio scarico acqua centrale
- B drenaggio binario
- G drenaggio valvola 9 mm
- H drenaggio binario - Ø8 mm
- J drenaggio binario camera interna
- L clip-vite C9A003
- E drenaggio anta



DIME LAVORAZIONI - TG4116

C9K012
A

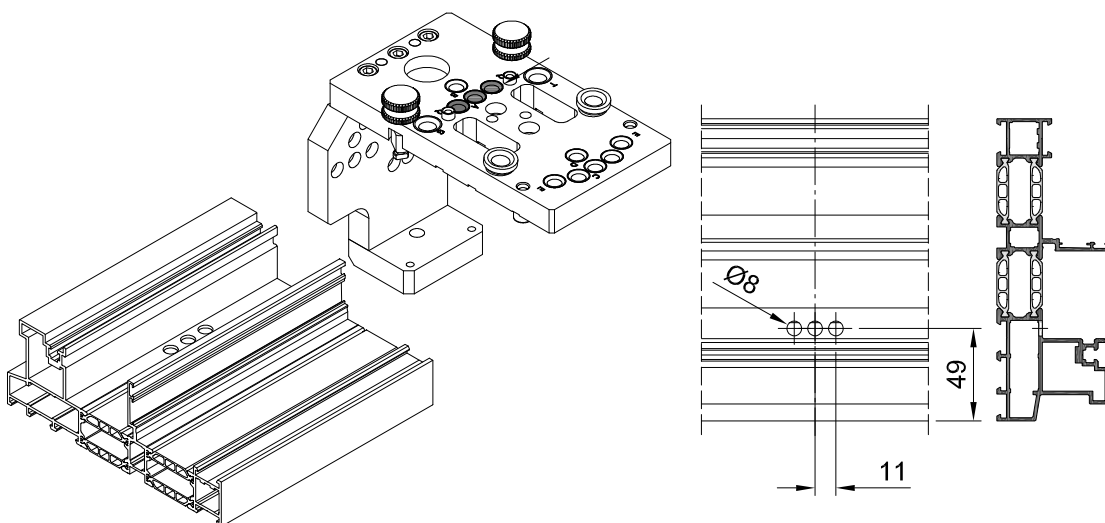

C9K012
B

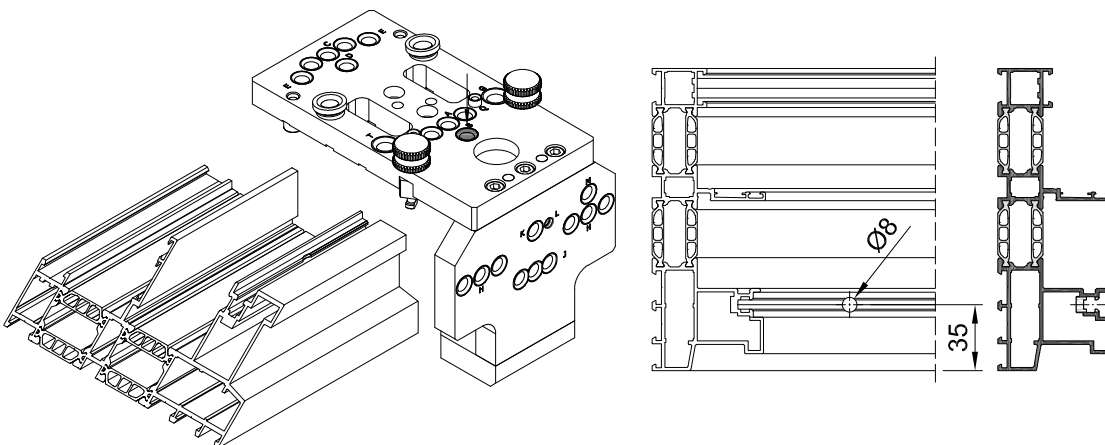

C9K012
G

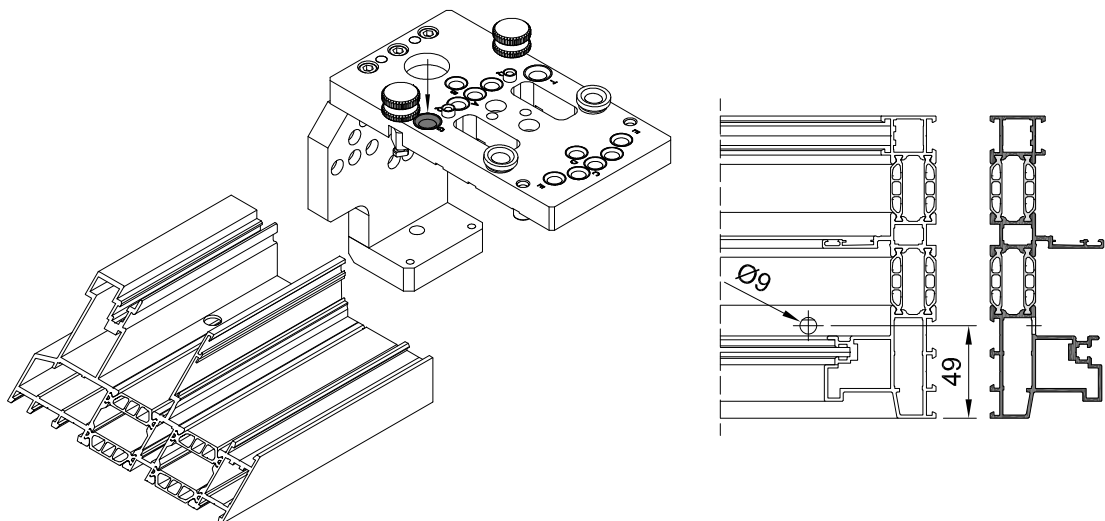

C9K012
H

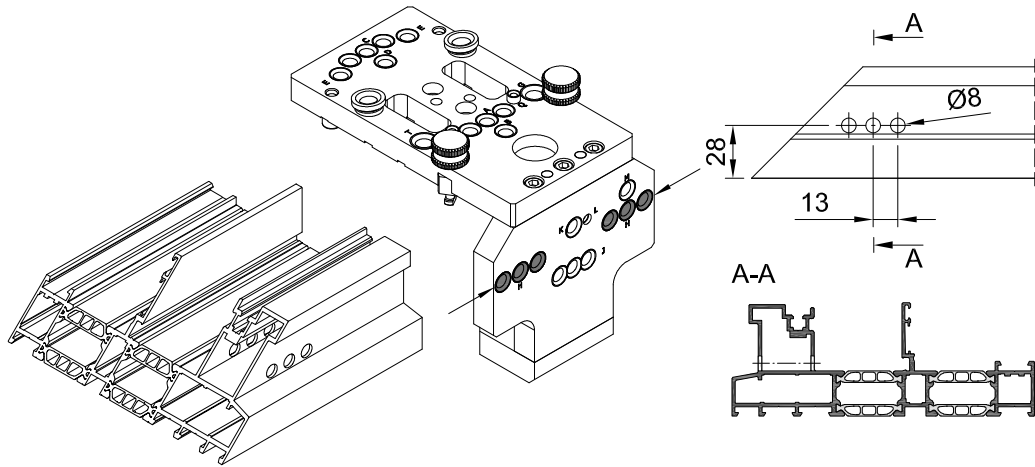

C9K012
J

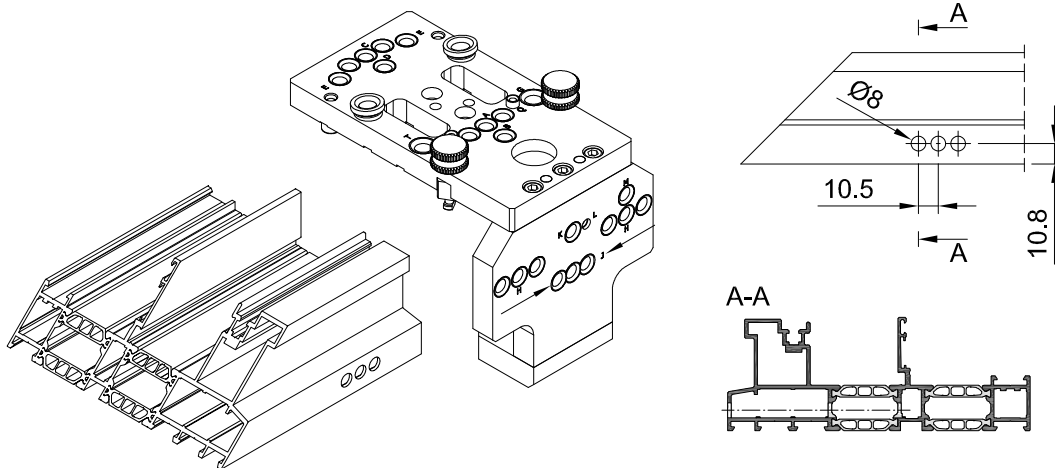

C9K012
L

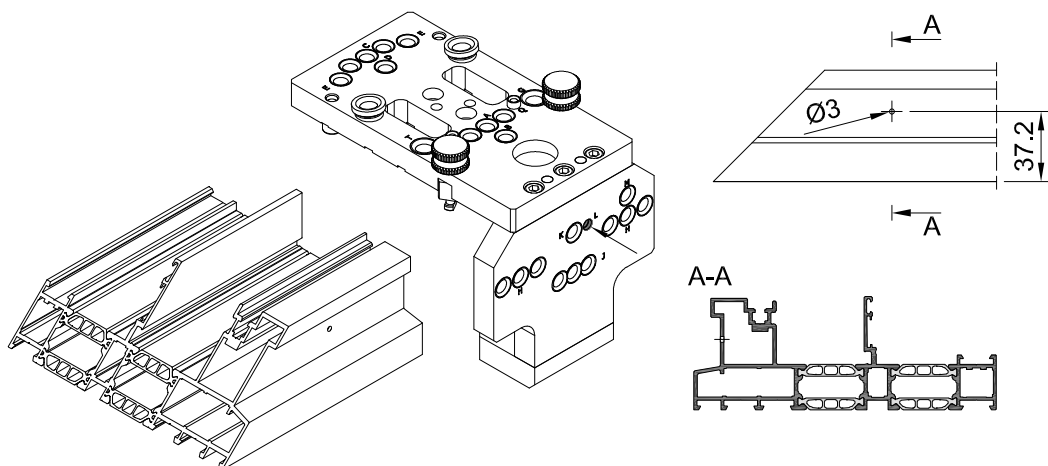



DIME LAVORAZIONI - TG4116

C9Vxxx
E

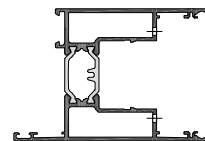
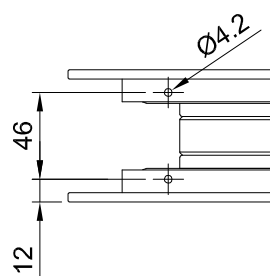
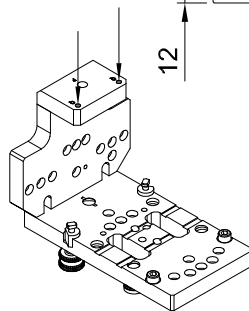
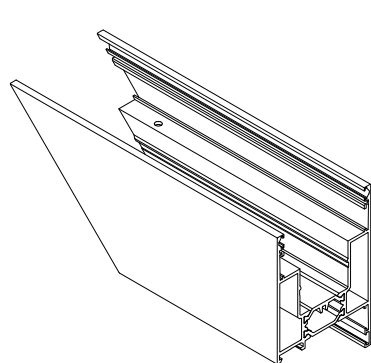

C9K120

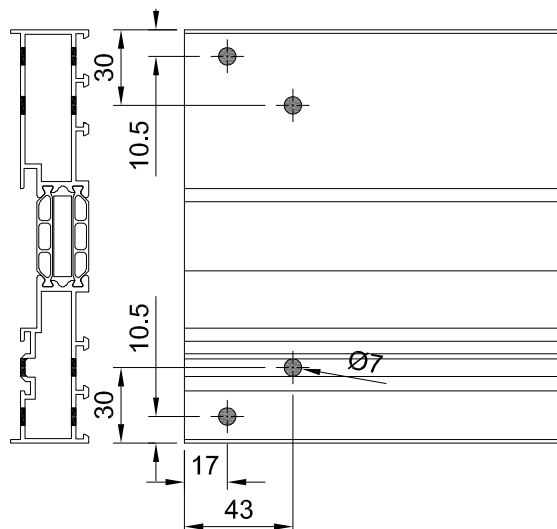
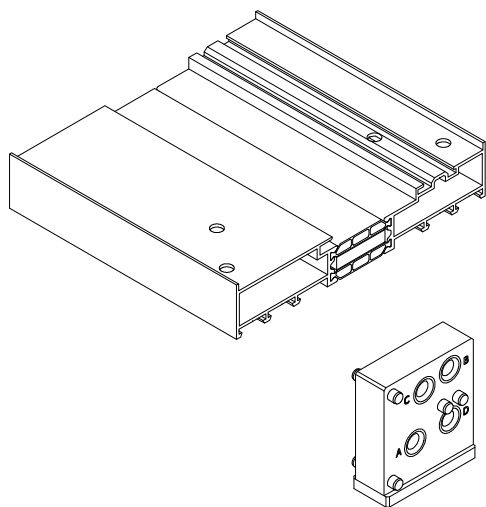

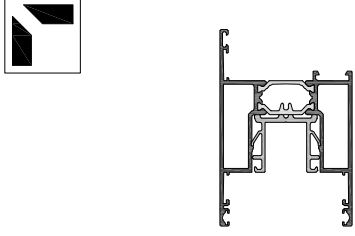
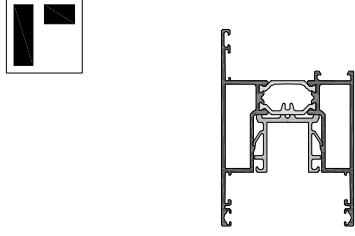
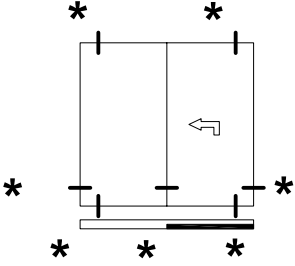
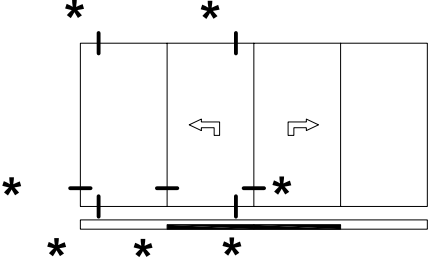
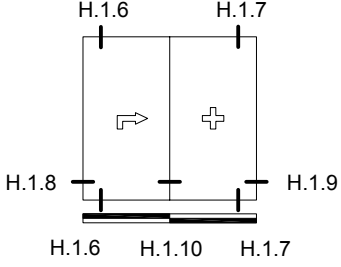
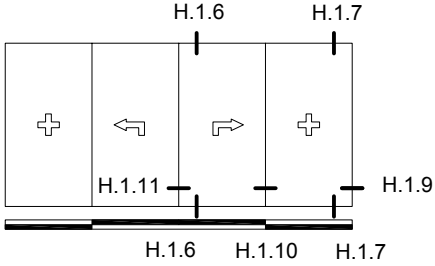
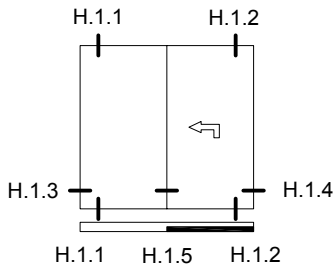
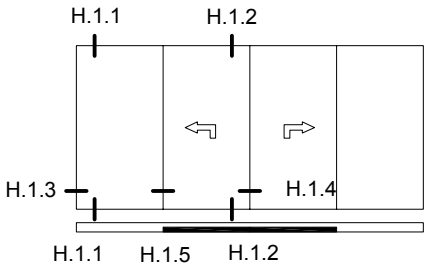

Nodi

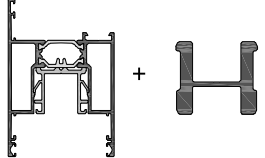
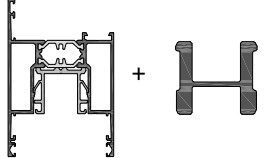
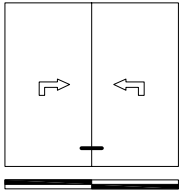
 <p>C9V001</p>	 <p>C9V001</p>
<p>C9K012</p>  	<p>C9K100 / C9K121 C9K120</p>  
<p>C9K010</p>  	

	 <p>C9V001 C9C001</p>		 <p>C9V051 C9C001</p>
	H.1.13		H.1.14

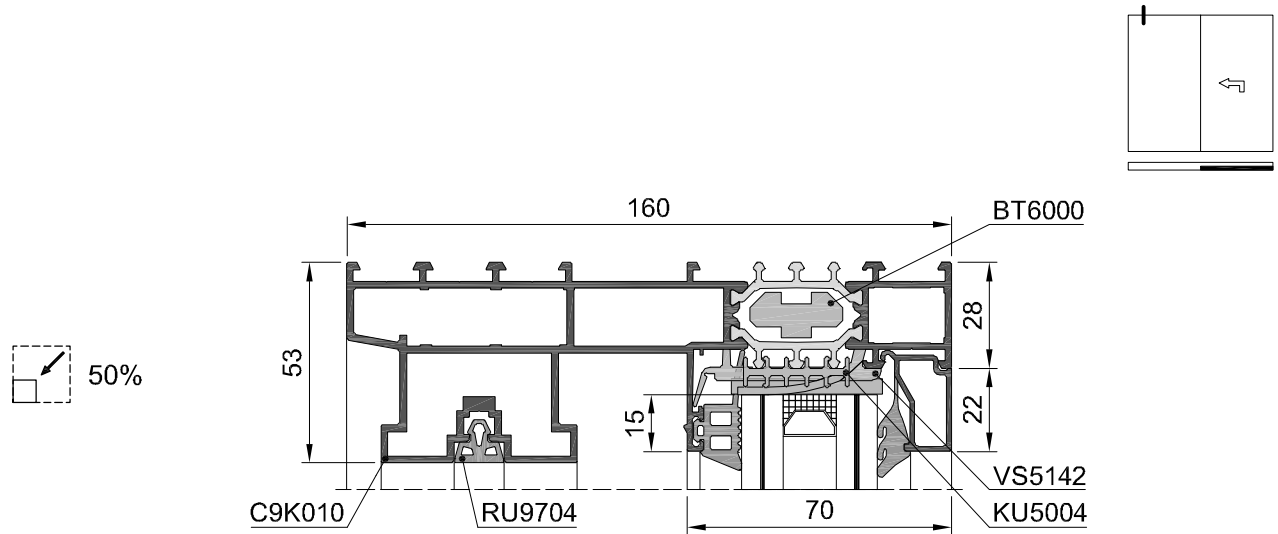
1-BINARIO (C9K010) - ALZANTE-SCORREVOLE - SUPERIORE SINISTRO



 **C160-SEC-045**

1-BINARIO (C9K010) - ALZANTE-SCORREVOLE - INFERIORE SINISTRO

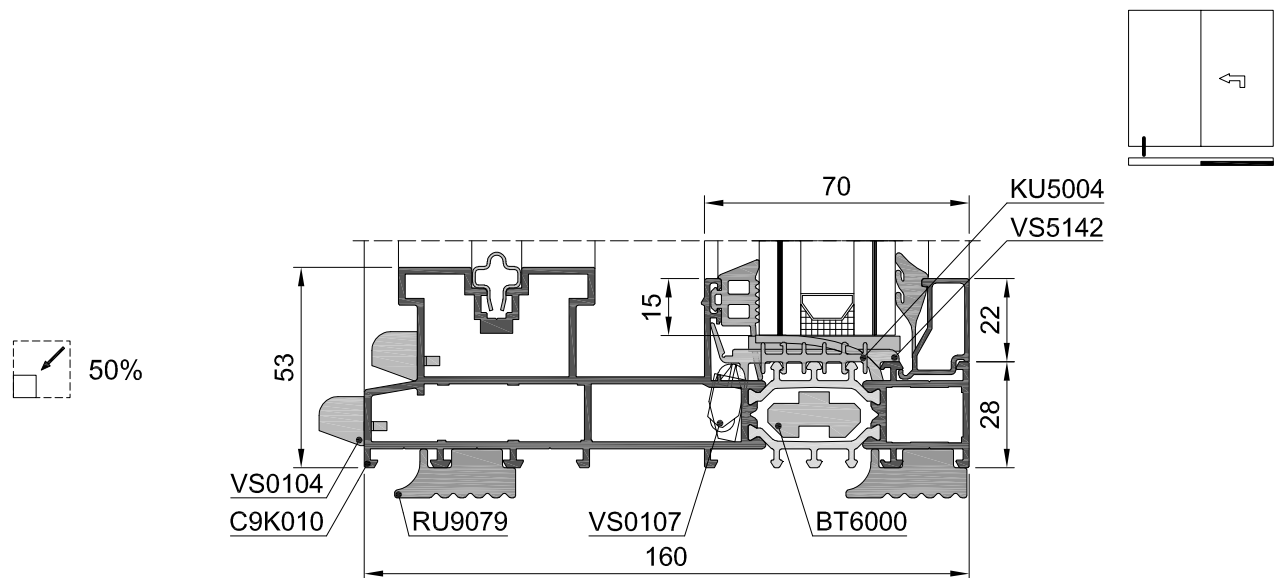

 **C160-SEC-043**

1-BINARIO (C9K010) - ALZANTE-SCORREVOLE - SUPERIORE DESTRO

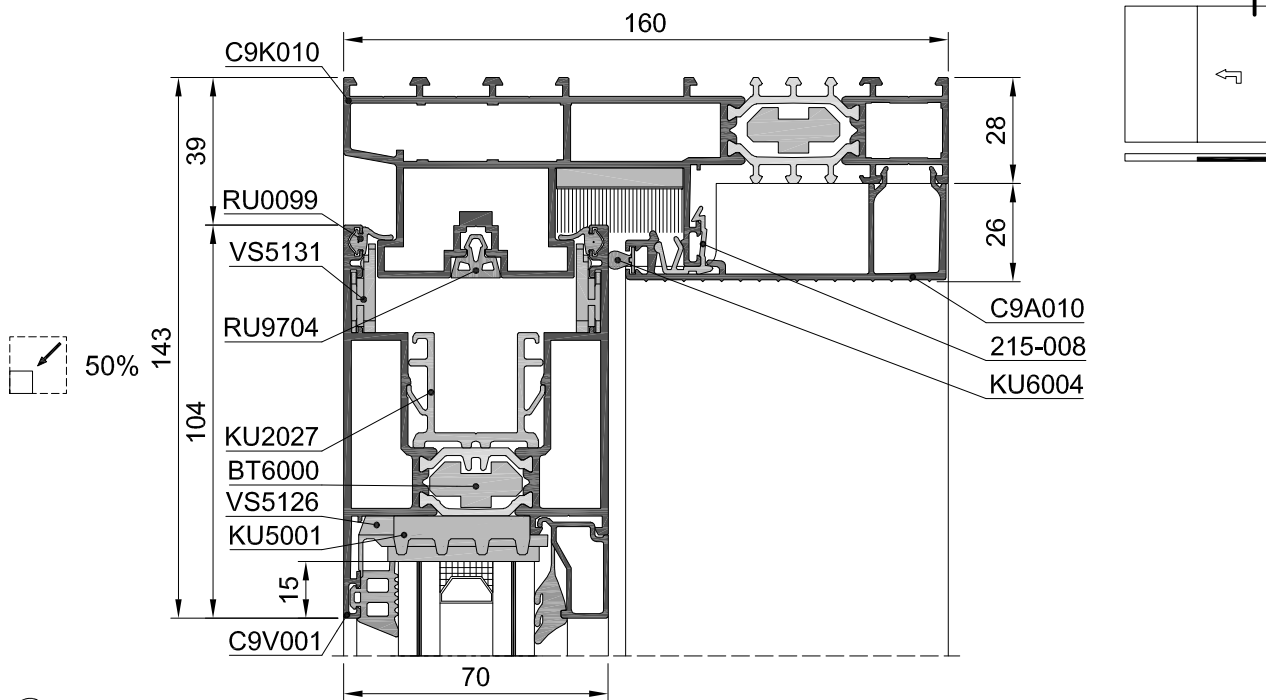

 **C160-SEC-044**

1-BINARIO (C9K010) - ALZANTE-SCORREVOLE - INFERIORE DESTRO

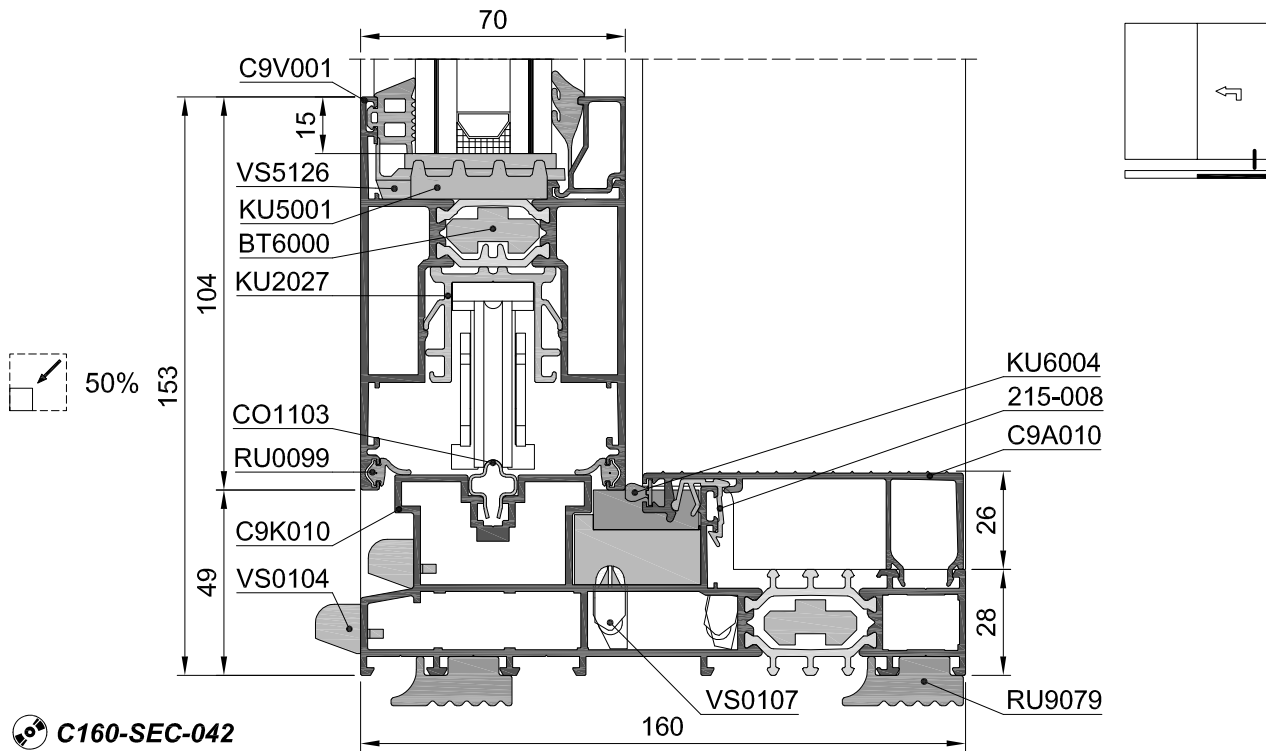

 **C160-SEC-042**

1-BINARIO (C9K010) - ALZANTE-SCORREVOLE - SINISTRO

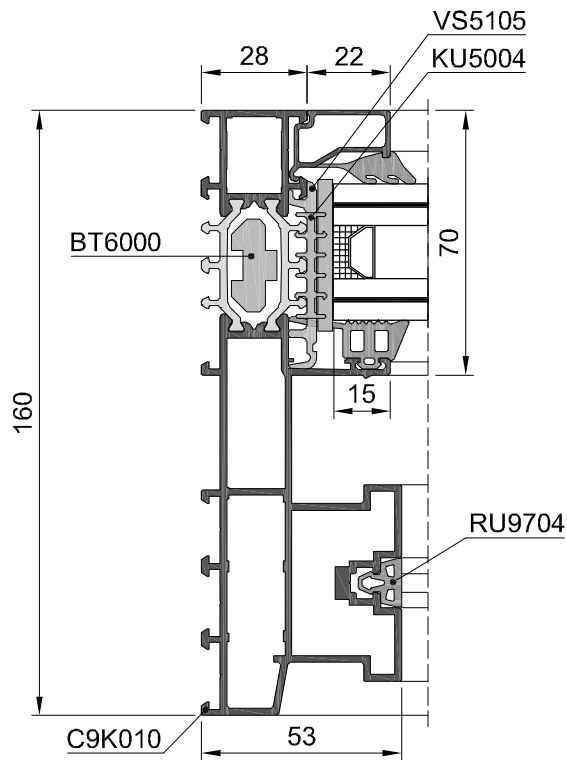
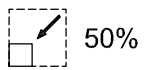
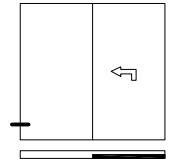

1-BINARIO (C9K010) - ALZANTE-SCORREVOLE - DESTRO

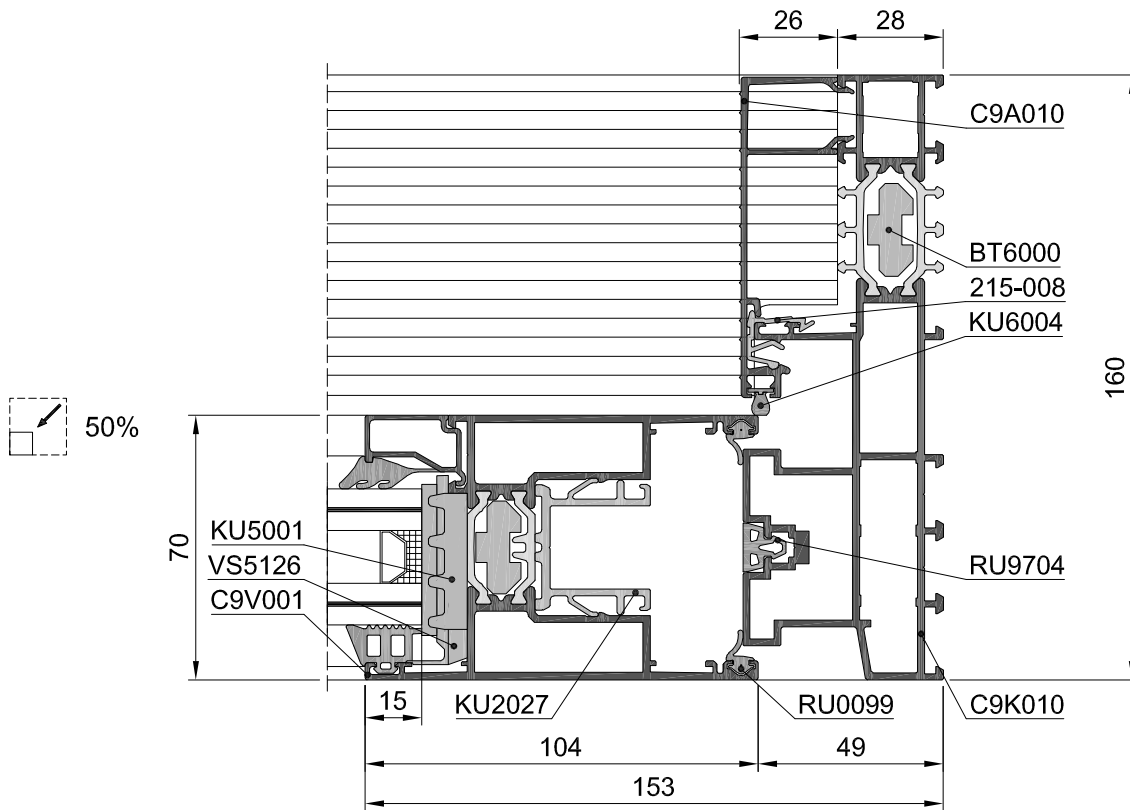
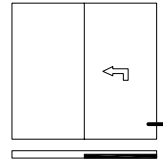

1-BINARIO (C9K010) - ALZANTE-SCORREVOLE - CENTRALE

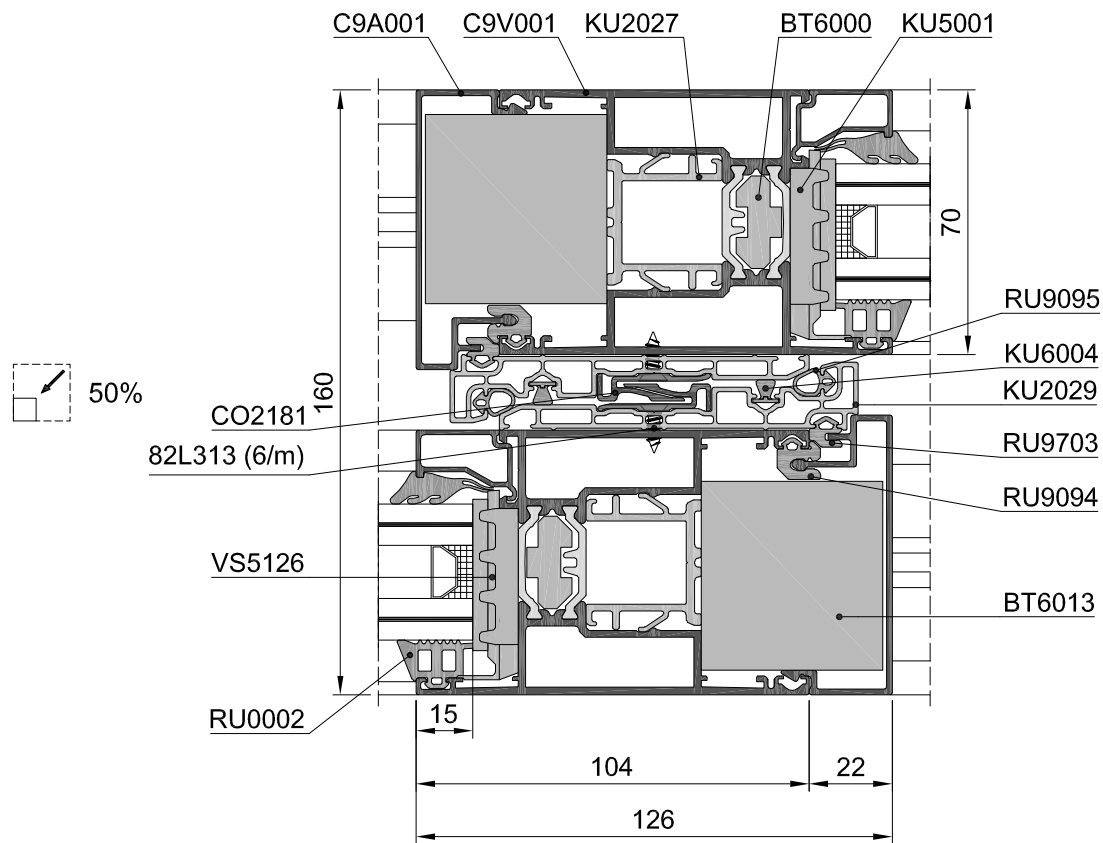
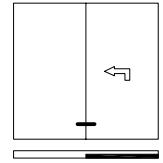

1-BINARIO SOGLIA RIBASSATA TAGLI 90° - ALZANTE-SCORREVOLE - SUPERIORE SINISTRO

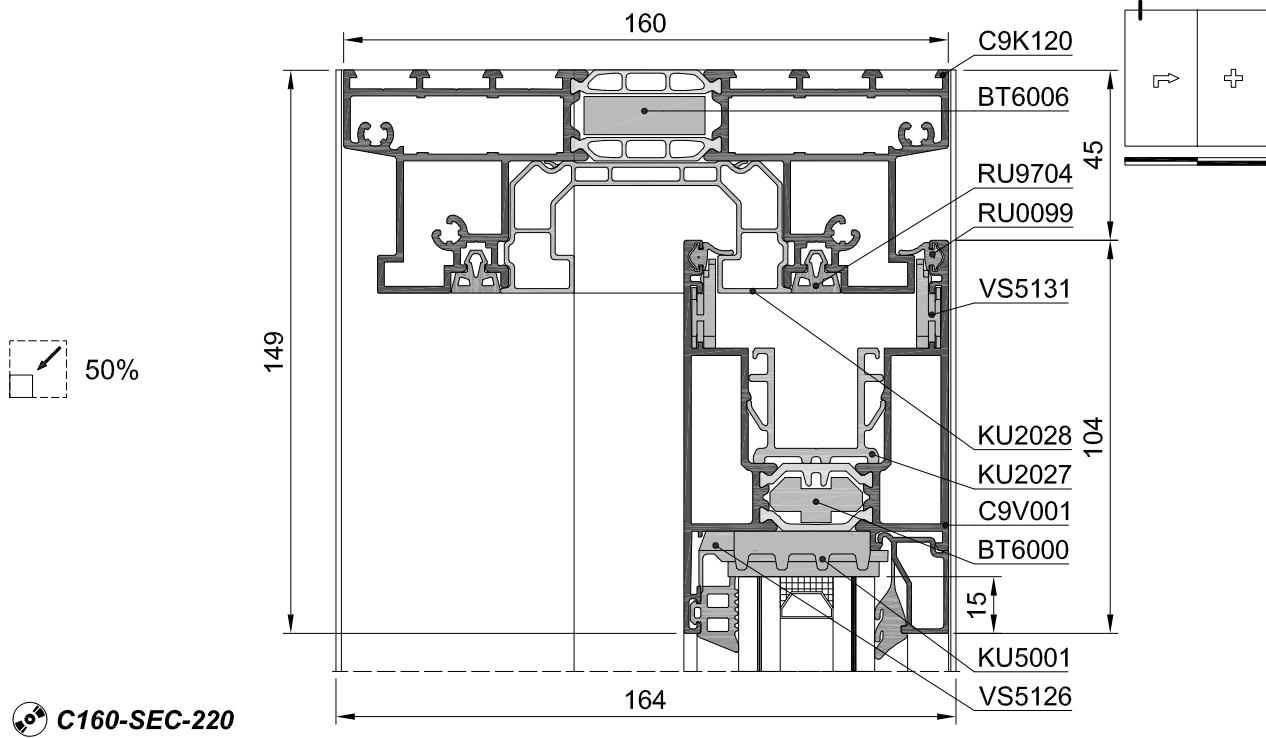

1-BINARIO SOGLIA RIBASSATA TAGLI 90° - ALZANTE-SCORREVOLE - INFERIORE SINISTRO

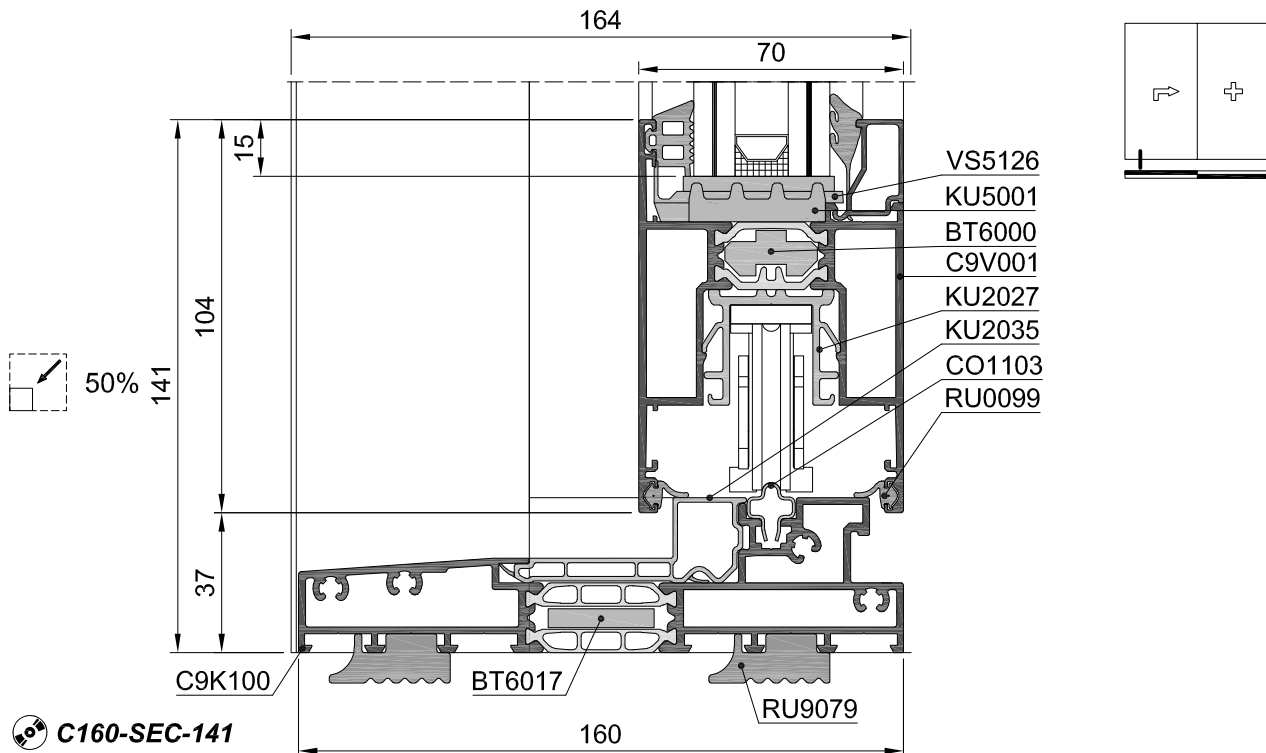

1-BINARIO SOGLIA RIBASSATA TAGLI 90° - ALZANTE-SCORREVOLE - SUPERIORE DESTRO

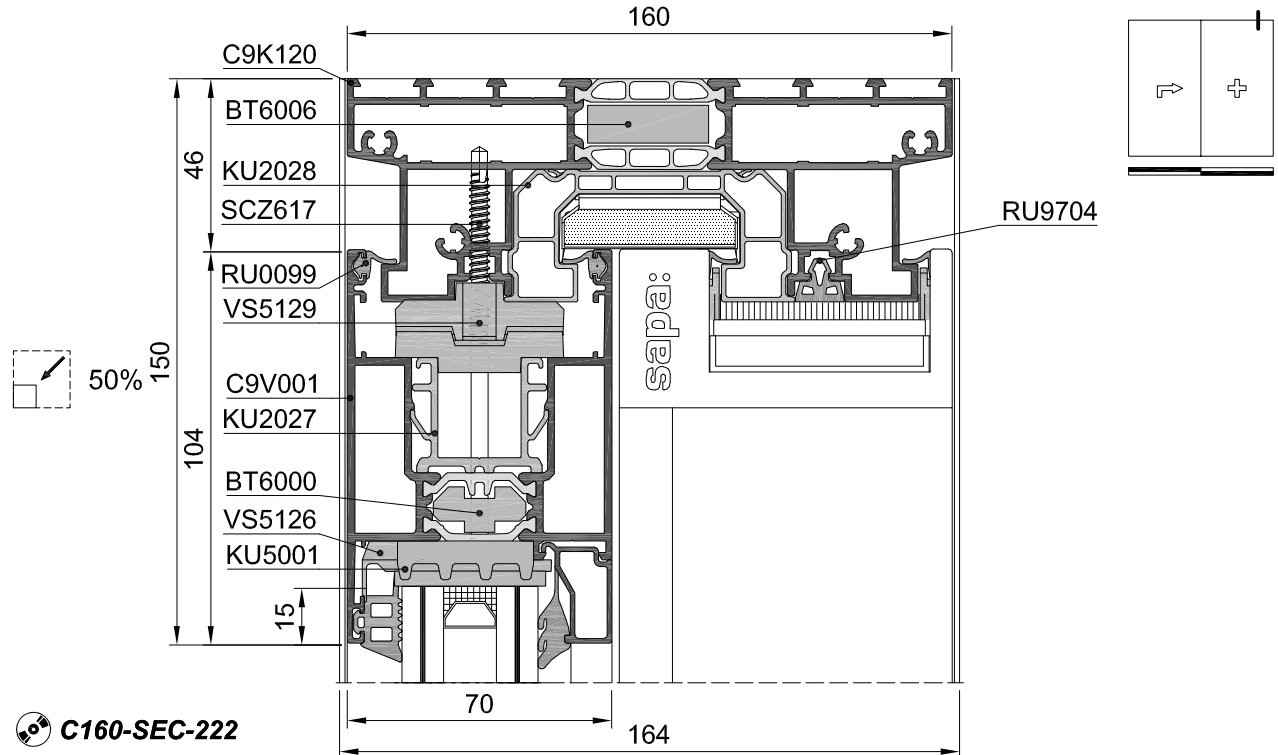

1-BINARIO SOGLIA RIBASSATA TAGLI 90° - ALZANTE-SCORREVOLE - INFERIORE DESTRO

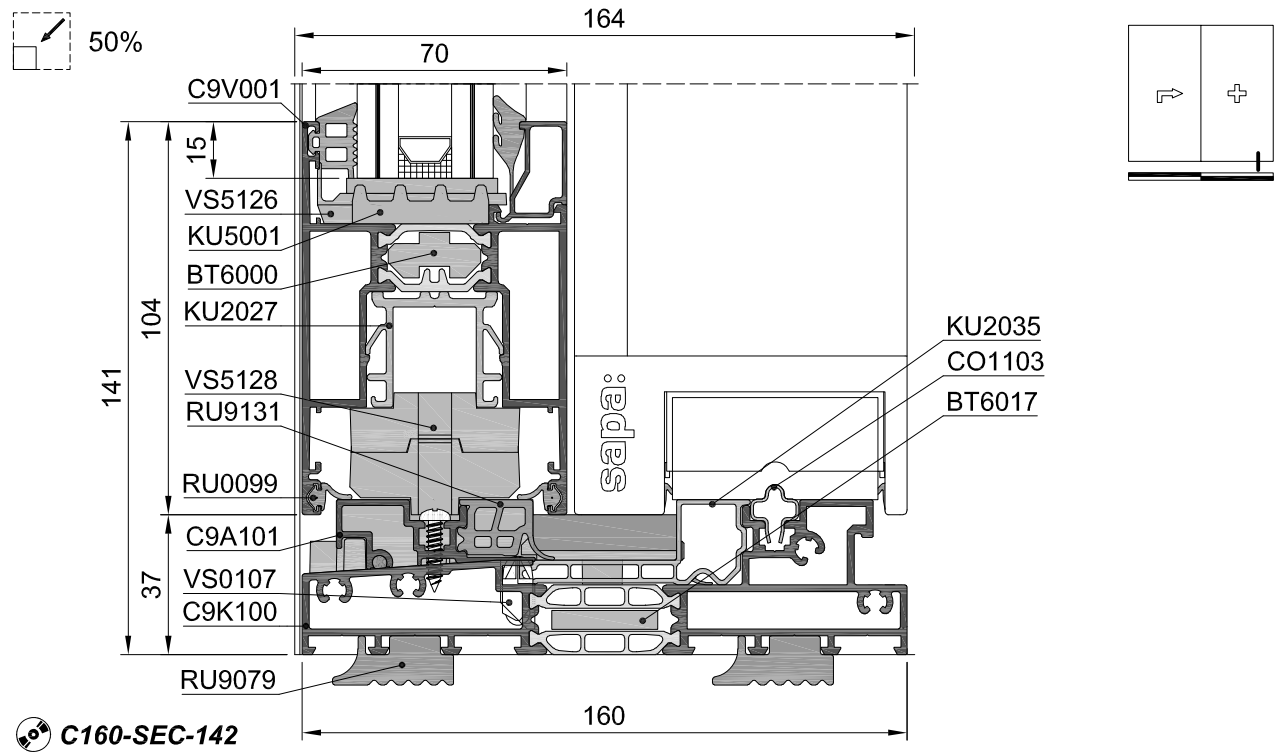

1-BINARIO SOGLIA RIBASSATA TAGLI 90° - ALZANTE-SCORREVOLE - SINISTRO

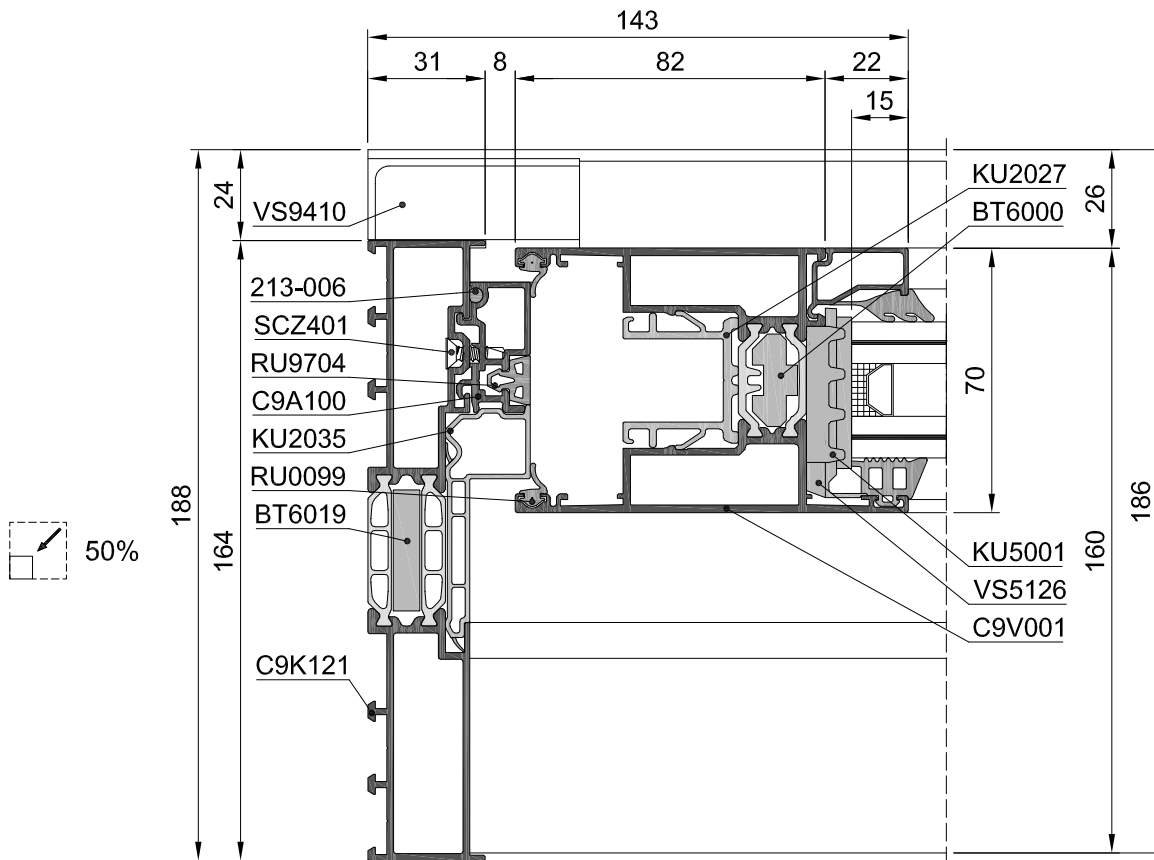
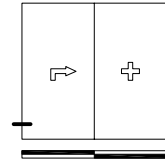

1-BINARIO SOGLIA RIBASSATA TAGLI 90° - ALZANTE-SCORREVOLE - DESTRO

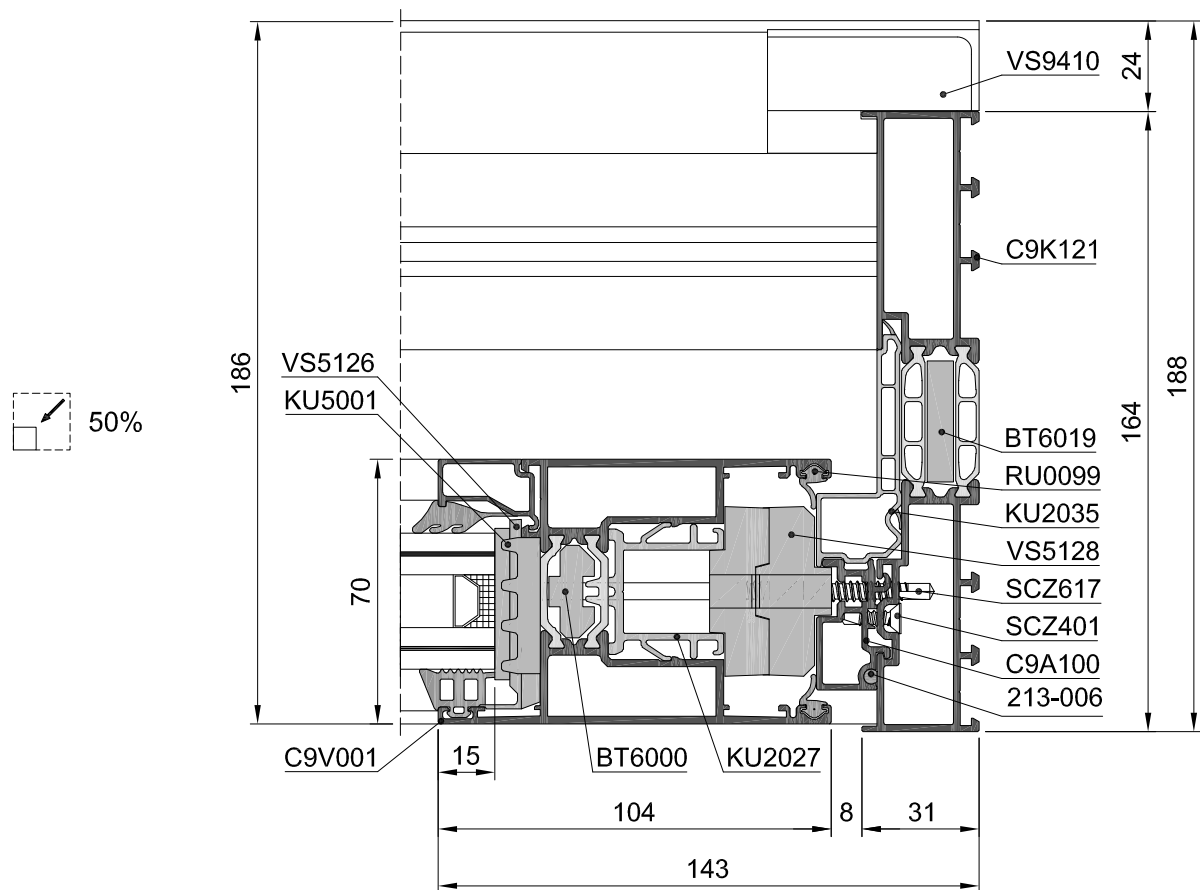
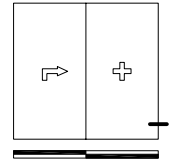

1-BINARIO SOGLIA RIBASSATA TAGLI 90° - ALZANTE-SCORREVOLE - CENTRALE

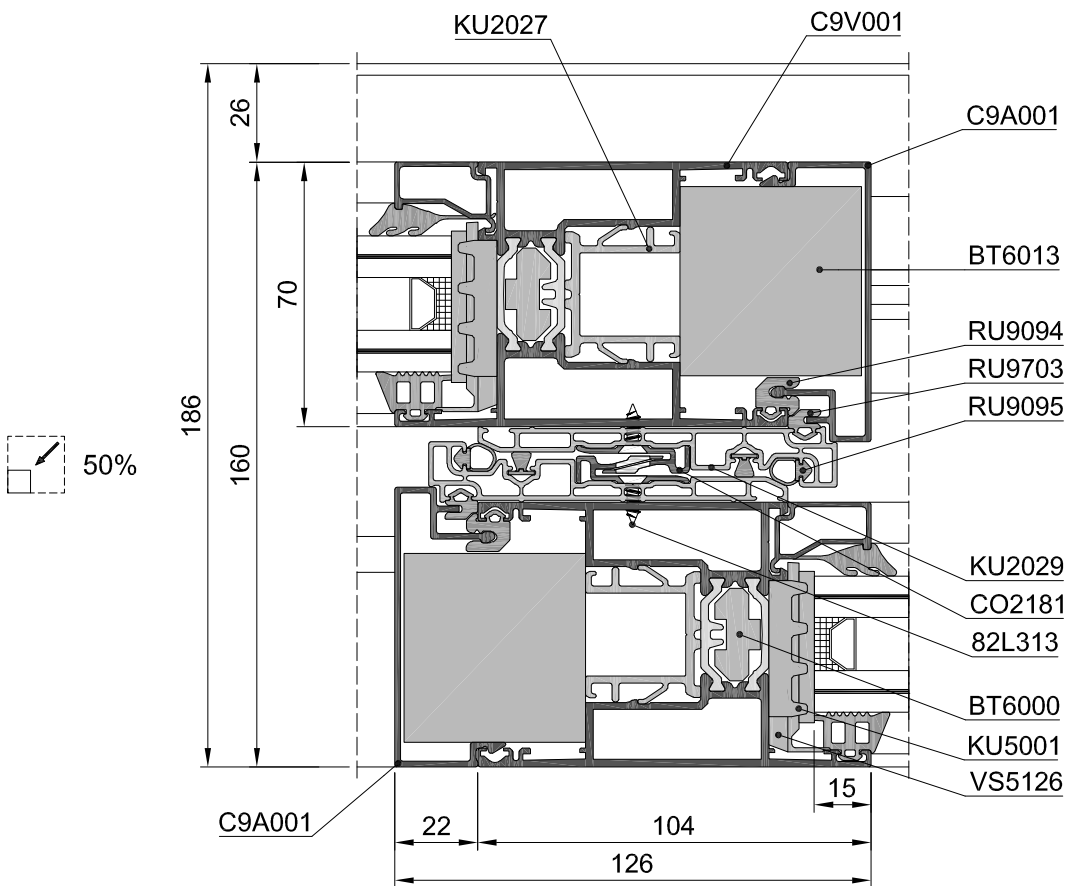
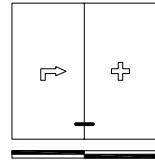

1-BINARIO SOGLIA RIBASSATA TAGLI 90° - ALZANTE-SCORREVOLE - CENTRALE

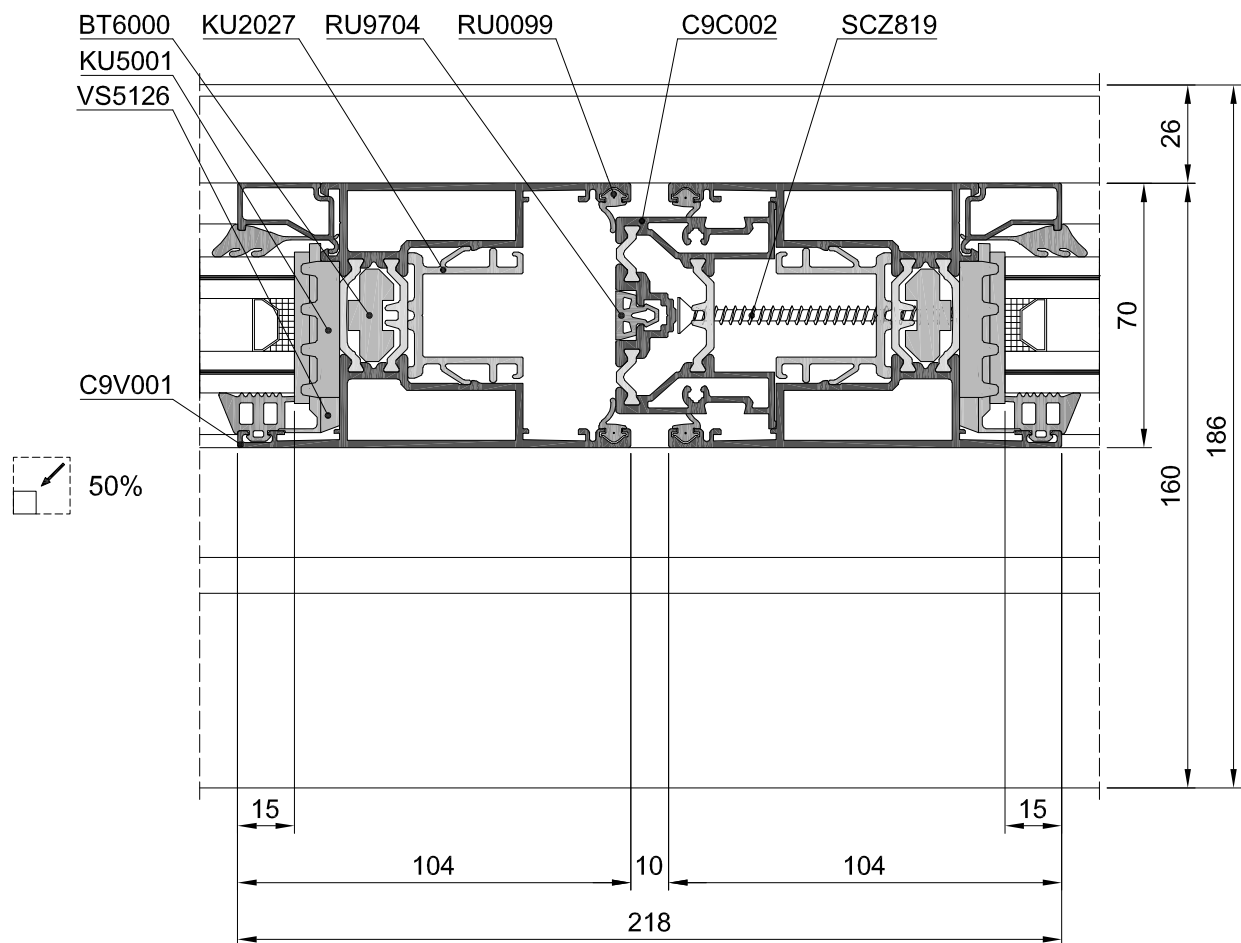
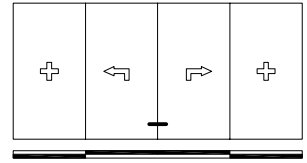

RINFORZO INTERNO - 1 ANTA

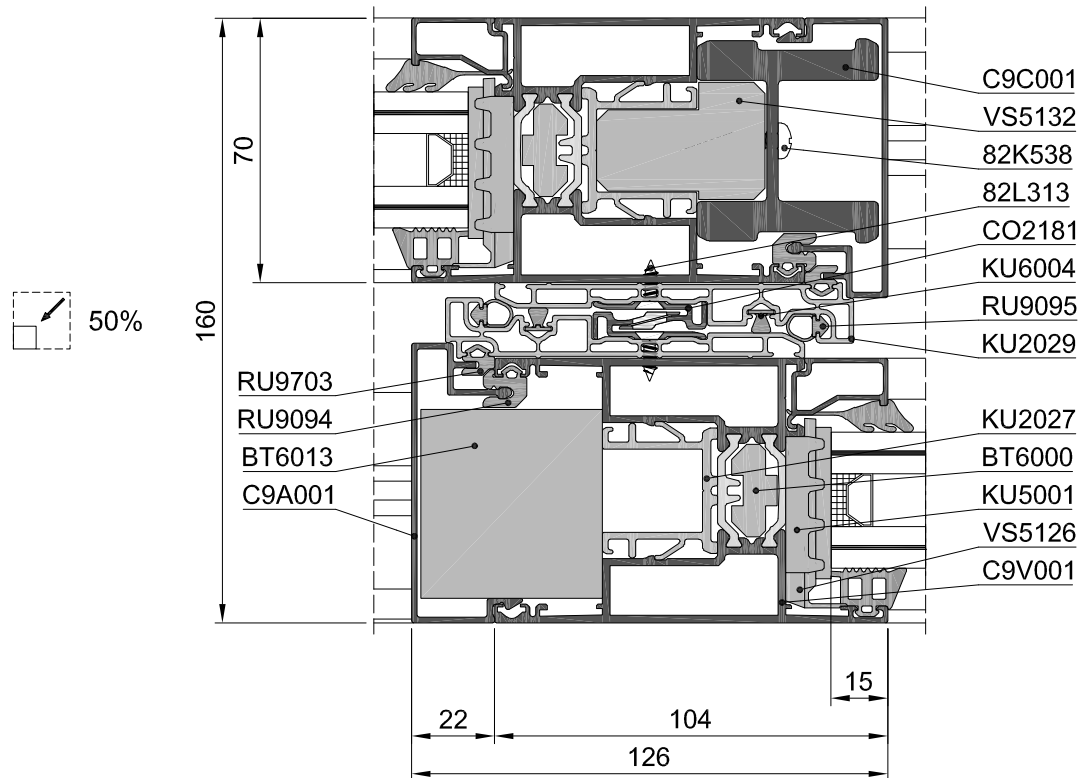
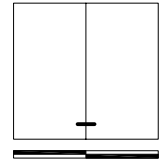

RINFORZO INTERNO - 2 ANTE

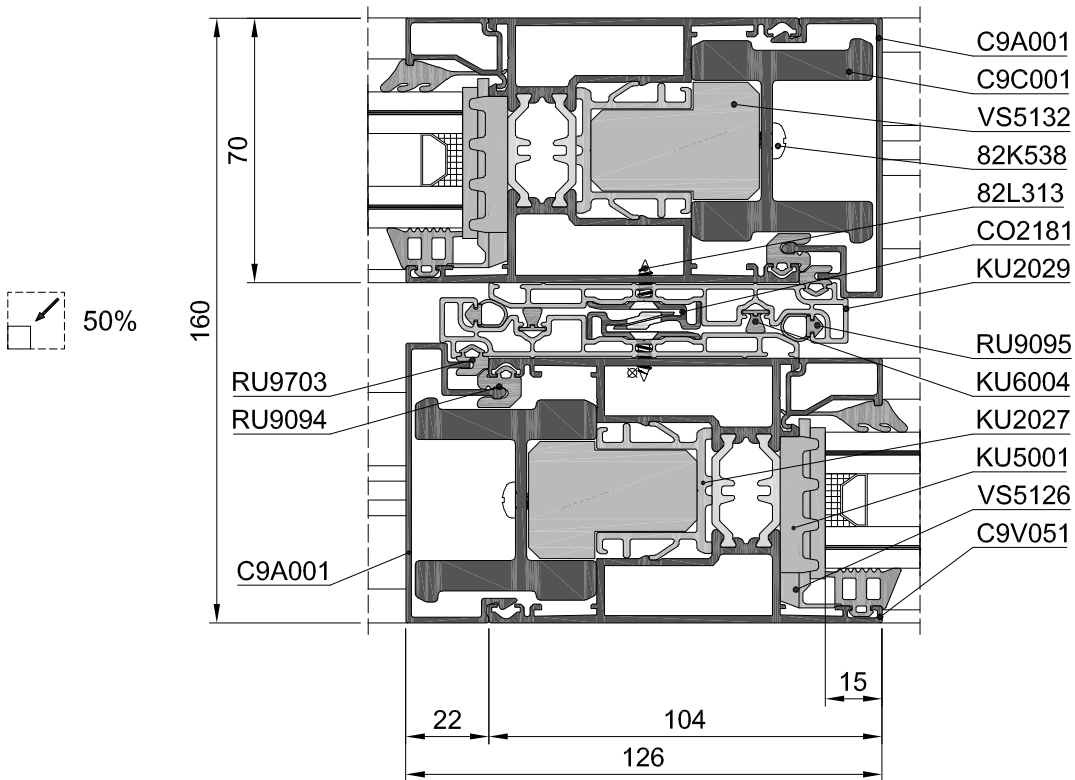
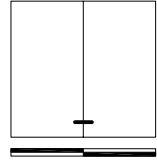

Distinte di taglio



DIRETTIVE GENERALI

1. Le pagine seguenti racchiudono le liste di taglio e la descrizione degli accessori per consentire il calcolo rapido dei materiali. Tuttavia, queste liste mostrano una selezione delle applicazioni più comuni del sistema. Misure di taglio piani di combinazioni di applicazioni o situazioni che non sono in questi elenchi saranno fornite su richiesta.
2. È possibile calcolare le dimensioni delle finestre in maniera semplice o più complessa.
3. Esempio di definizione di "esterno" e "interno" per nodo orizzontale e verticale.

Interno

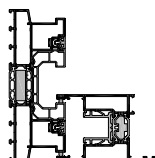

Esterno

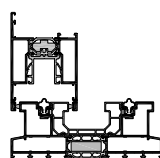

Interno

Esterno

4. Le misure L e H corrispondono alla rispettiva larghezza e altezza del telaio.

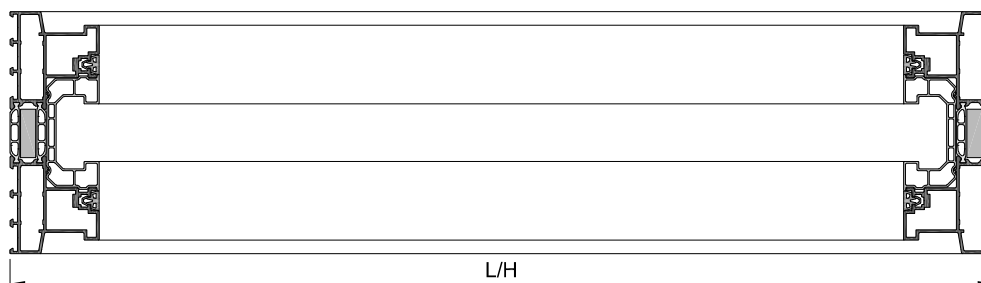



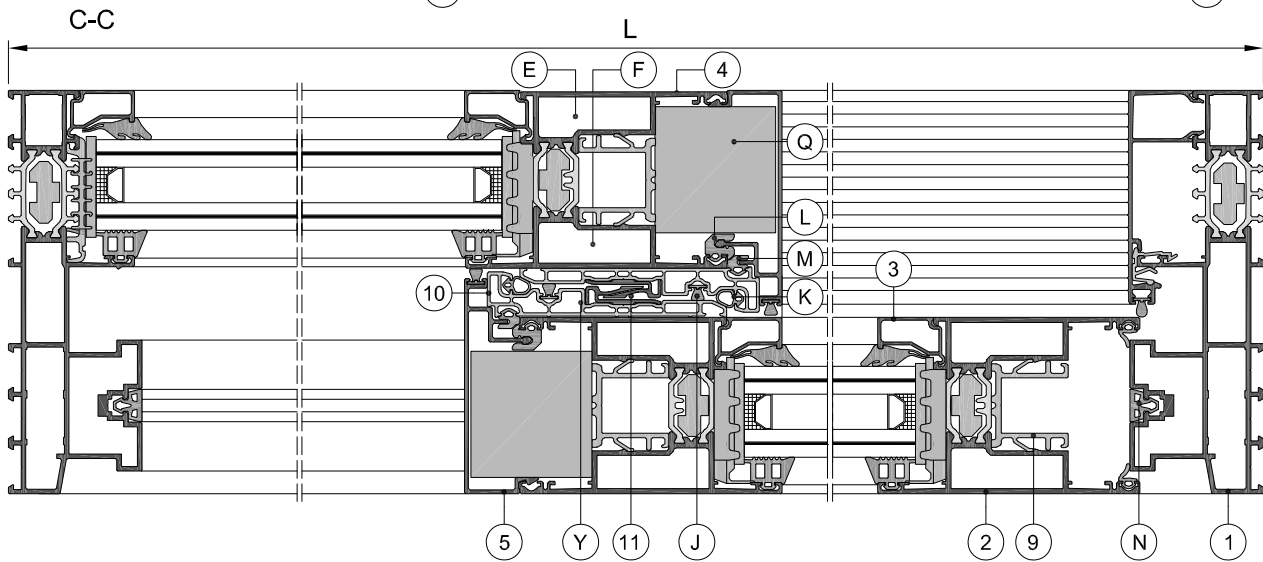
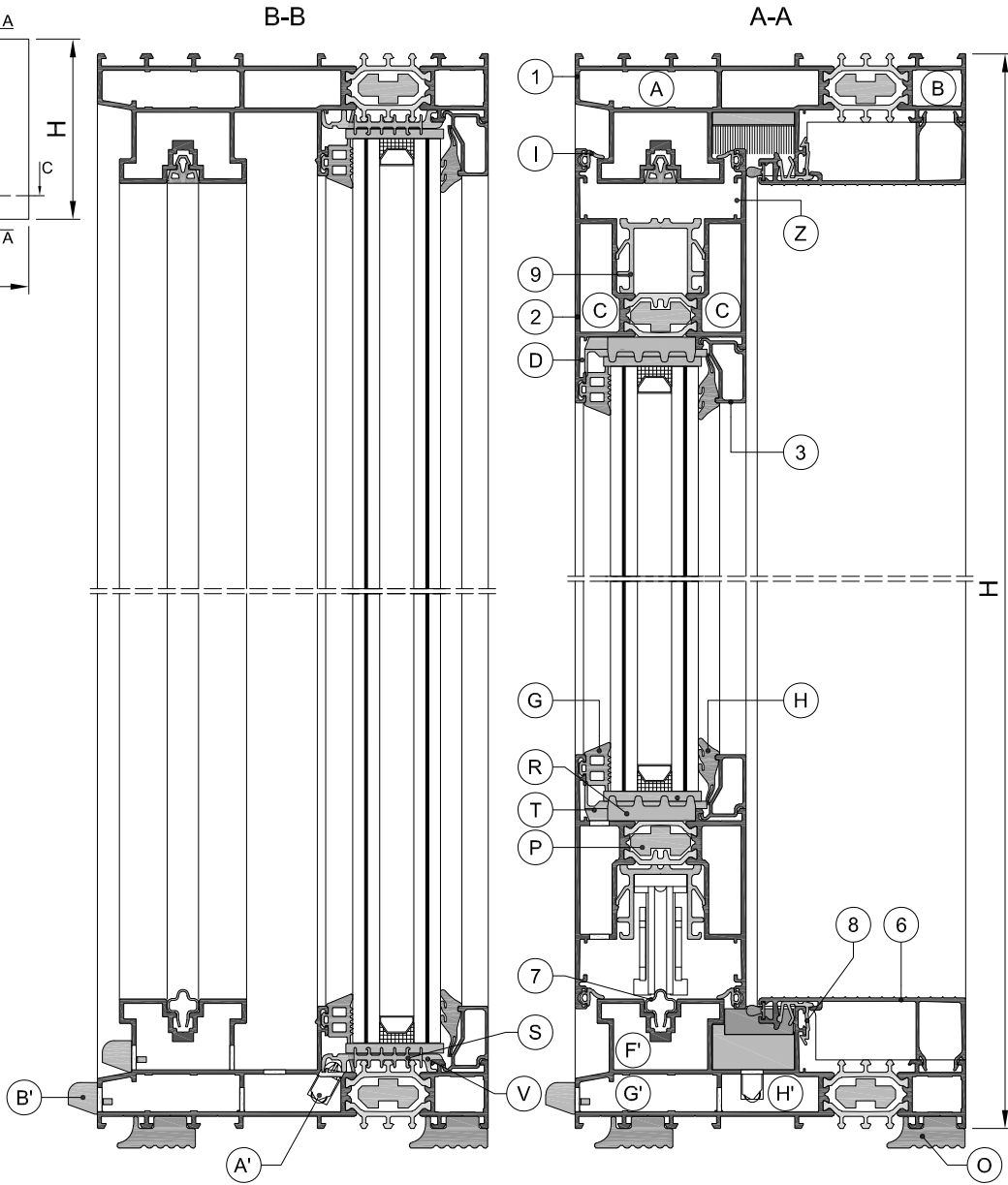
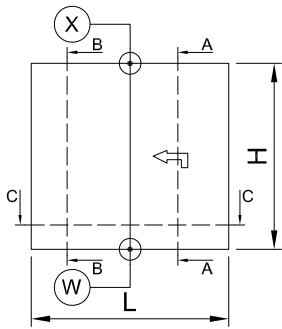





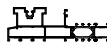













5. I parametri consentono di calcolare l'intera gamma di telai, ante e traverse.
6. Si prega di consultare la sezione E per una scelta alternativa di accessori e i capitoli F e J per la ferramenta
7. Fissaggi: per lato almeno due ancoraggi, max. distanza intermedia di 750 mm. Essi sono posti in prossimità di angoli e punti di chiusura punti e sono distanti da angoli e/o traverse alla misura di 200 mm. Essi non sono inclusi nelle distinte consultabili anche nel capitolo J assemblaggio.
8. Vetratura: per informazioni sull'installazione supporti vetri e piani di appoggio, vedere il capitolo J assemblaggio. I fermavetri hanno un'altezza uniforme di 22 mm. (vedi capitolo D vetri).





1-BINARIO 1-ANTA ALZANTE SCORREVOLE + FISSO TELAIO 45°

	PROFILATI		QUANTITA'	TAGLIO	LUNGHEZZA TAGLIO	
1		C9K01E	2 2		L H	
2		C9V001	2 2		L/2 + 43.5 H - 88	
3		GCxxxx	4 2 2		L/2 - 120.5 H - 100 H - 296	
4		C9V001	1		H - 56	
5		C9A002	1 1		H - 56 H - 172	
6		C9A010	2 1		L/2 - 39.5 H - 108	
7		CO1103	1		L - 106	
8		215-008	2 1		L/2 - 76 H - 120	
9		KU2027	2 2 1		L/2 - 13.5 H - 145 H - 56	
10		KU2029	2		H - 92	
11		CO2181	2		H - 92	
	DIMENSIONE VETRI				L/2 - 134.5	H - 266 H - 70

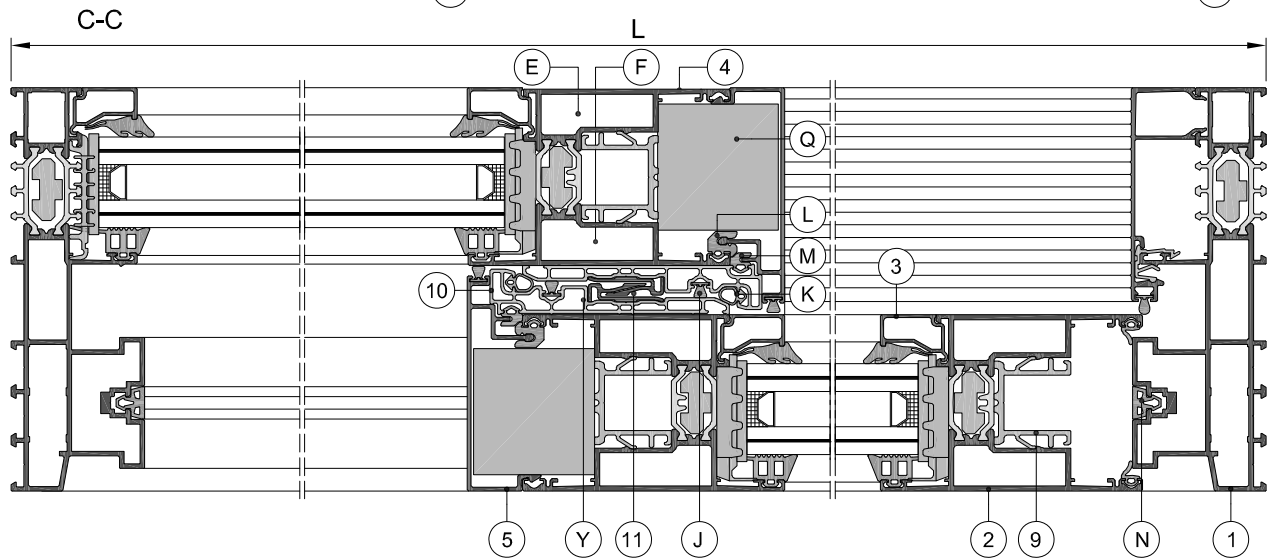
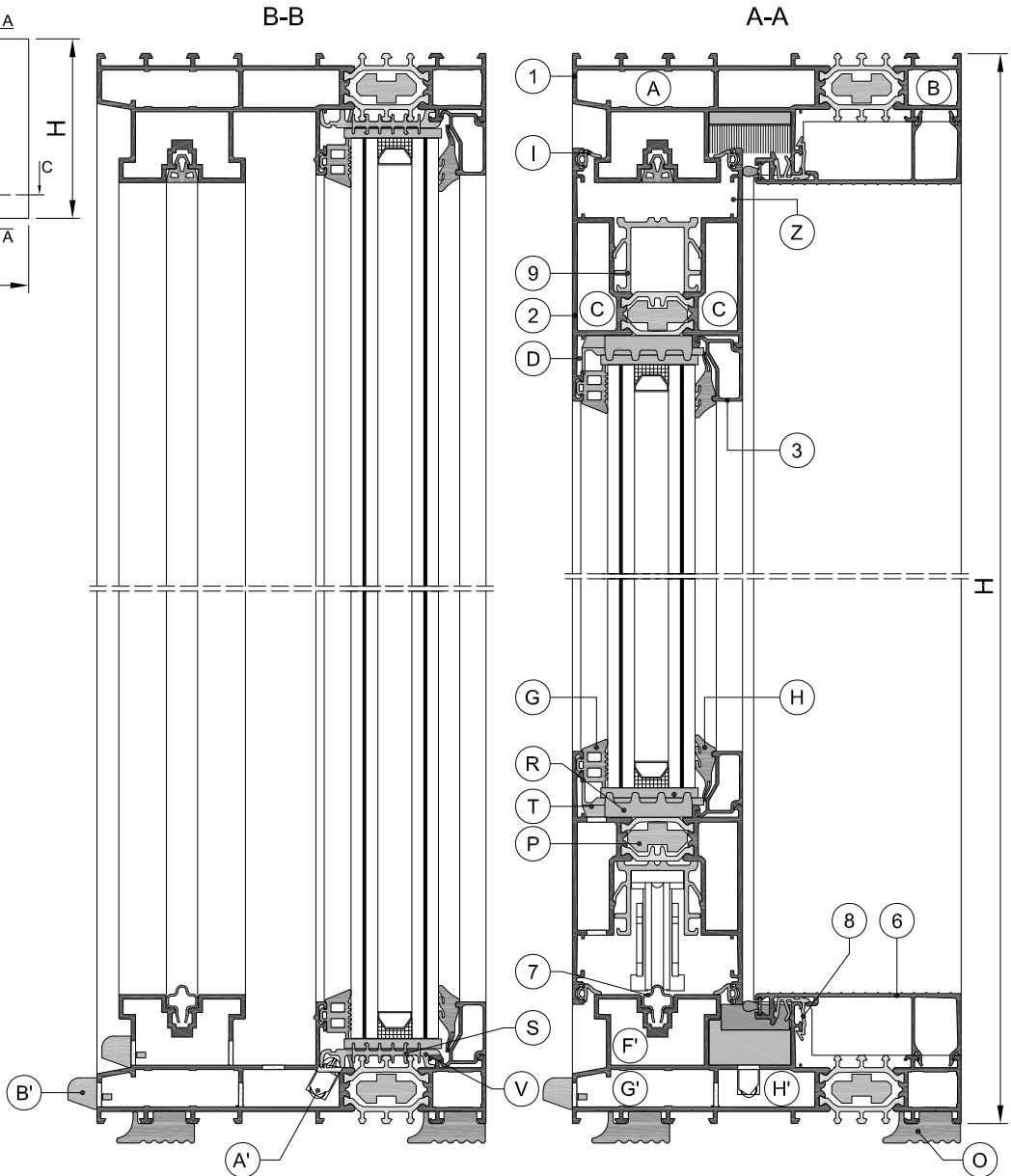
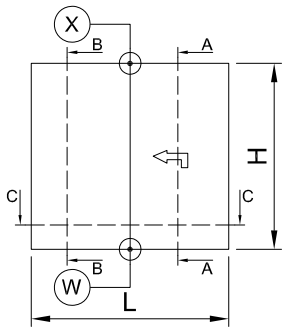



1-BINARIO 1-ANTA ALZANTE SCORREVOLE + FISSO TELAIO 45°

	ACCESSORI	QUANTITA'
A	HV0G03 / 778500	4 / 16
B	HV0H01 / 778500	4 / 8
C	HV3H26 / 778500 / 71C011	8 / 16 / 16
D	HV4K00 / HV4K01	8 / 4 + 4
E	TS3M03 / 778500 / 82L416	2 / 2 / 2
F	TS3M04 / 778500 / 82L416	2 / 2 / 2
G	RU0002	2 (L + 2H)
H	39R507	2 (L + 2H)
I	RU0099	2L + 2H
J	KU6004	L + 5H
K	RU9095	2H
L	RU9094	2H
M	RU9703	2H
N	RU9704	L + 2H
O	RU9079 - FACOLTATIVA	2L
P	BT6013-VERSIONE SI	2H
Q	BT6000-VERSIONE SI	2L + 5H

	ACCESSORI	QUANTITA'
R	KU5001-VERSIONE SHI	L + 3H
S	KU5004-VERSIONE SHI	L + H
T	VS5130	8
V	VS511 G	4
W	CO1116	1
X	CO1114	1
Y	VS9148 (set)	2
Z	VS5131	4
A'	VS0107	3
B'	D4074009	VEDI PAG. J.1.4
C'	VS9149 (set)	1
D'	CO1107	1
E'	CO1110	1
F'	VS9958	2
G'	VS9951	2
H'	VS9959	2
	TS9Z05	4
	SV9002	1

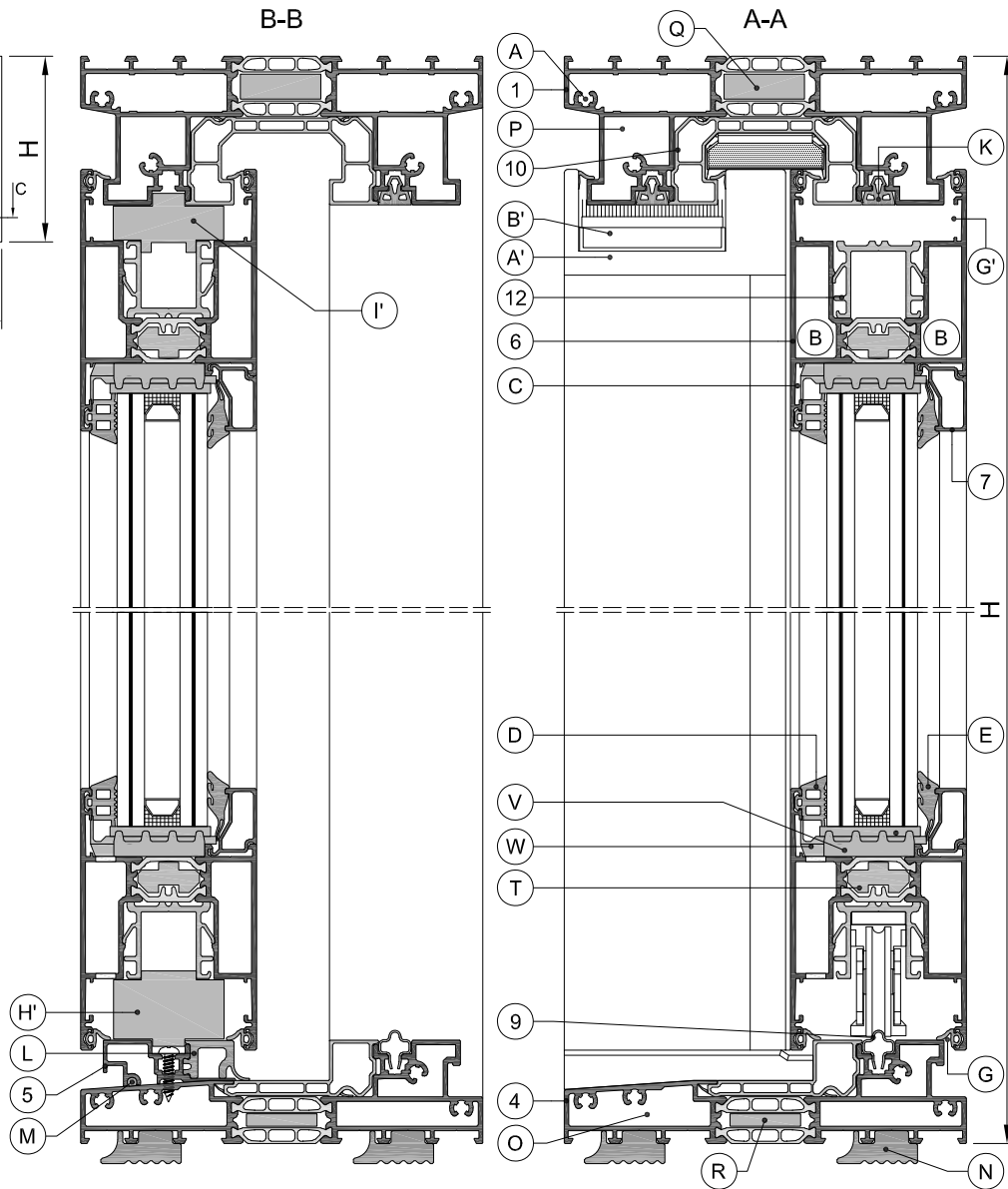
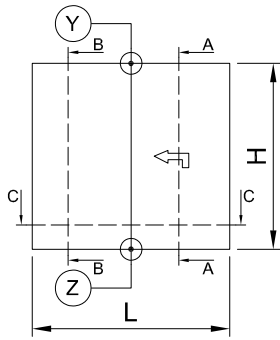

C-C

L

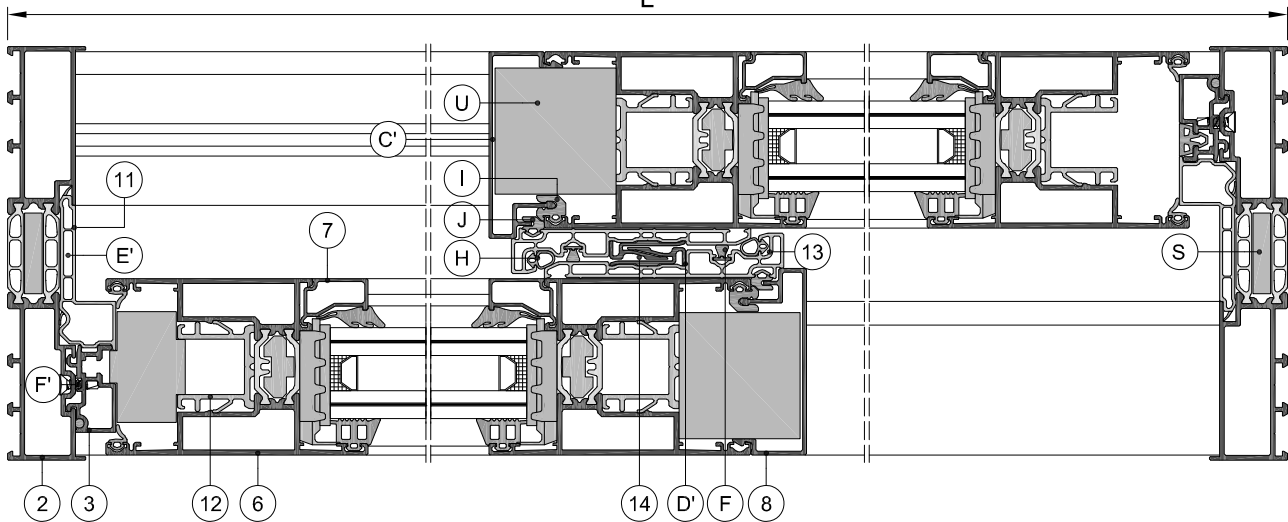



1-BINARIO 1-ANTA ALZANTE SCORREVOLE+ANTA FISSA TELAIO 90°

	PROFILATI		QUANTITA'	TAGLIO	LUNGHEZZA TAGLIO	
1		C9K120	1		L - 57	
2		C9K121	2		H	
3		C9A100	2		H - 100	
4		C9K100	1		L - 57	
5		C9A101	1		L/2 - 8.5	
6		C9V001	4 4		L/2 + 2 H - 82	
7		GCxxxx	4 4		L/2 - 162 H - 290	
8		C9A001	1 1		H - 166 H - 124	
9		CO1103	1		L - 71	
10		KU2028	1		L - 57	
11		KU2035	2 1		H - 100 L - 57	
12		KU2027	2 2		L/2 - 55 H - 139	
13		KU2029	2		H - 86	
14		CO2181	2		H - 86	
DIMENSIONE VETRI					L/2 - 176	H - 260

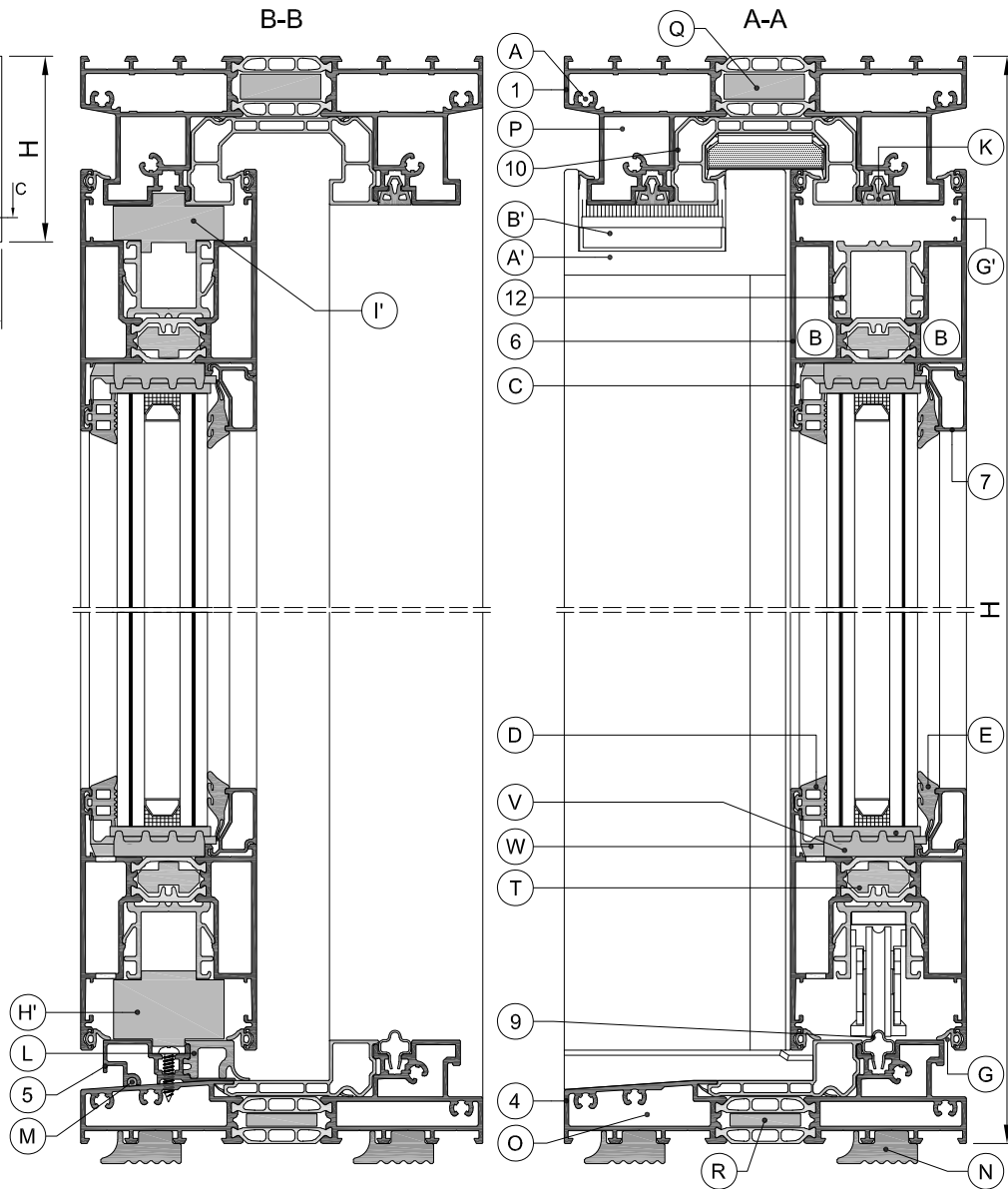
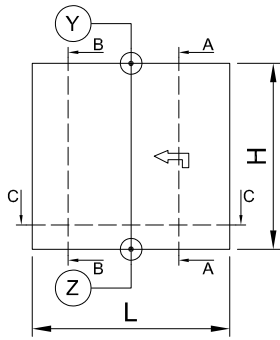

C-C

L

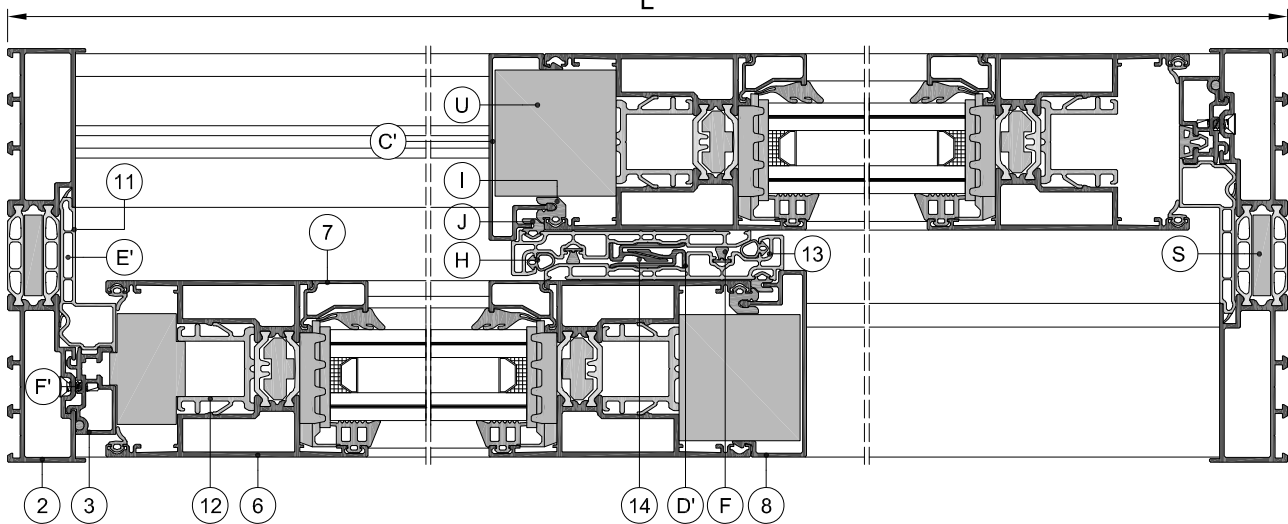



1-BINARIO 1-ANTA ALZANTE SCORREVOLE+ANTA FISSA TELAIO 90°

	ACCESSORI	QUANTITA'
A	787-570	16
B	HV3H26 / 778500 / 71C011	16 / 32 / 32
C	HV4K00 / HV4K01	16 / 8
D	RU0002	2L + 4H
E	39R507	2L + 4H
F	KU6004	2H
G	RU0099	4L + 4H
H	RU9095	2H
I	RU9094	2H
J	RU9703	2H
K	RU9704	2L + 2H
L	RU9131	0.5L
M	213-006	0.5L + 2H
N	RU9079 - FACOLTATIVA	2L
O	VS9970 + VS9971	1 + 1
P	VS9956	2
Q	BT6006-VERSIONE SI	L
R	BT6017-VERSIONE SI	L

	ACCESSORI	QUANTITA'
S	BT6019-VERSIONE SI	2H
T	BT6000-VERSIONE SHI	2L + 4H
U	BT6013-VERSIONE SI	2H
V	KU5001-VERSIONE SHI	2L + 4H
W	VS5130	16
Y	CO1111	1
Z	CO1136 / CO1137	1
A'	VS9149 (set)	2
B'	CO1110	2
C'	CO1107	2
D'	VS9148 (set)	2
E'	VS9957	4
F'	CO0132	4
G'	VS5131	4
H'	VS5128	5
I'	VS5129	2
	VS0107	2
	SV9002	1

**Ferramenta & disegni
assemblaggio**





ASSEMBLAGGIO GENERALE - E SPECIFICHE DI MONTAGGIO IN OFFICINA

Oltre alle tecniche e termini determinati dalle norme ufficiali (Nazionali ed Europee), alcune regole di base devono essere rispettate durante il montaggio e l'installazione di una finestra per produrre un prodotto di qualità.

Nel seguente, elenco, non limitato, le specifiche sono date per la costruzione, produzione e posa di finestre-, porte-, elementi di facciate.

1. Tagliare il profilato

Al fine di ottenere un buon taglio, è importante fissare bene e posizionare il profilato sulla troncatrice.

Il profilo deve sempre essere posizionato in modo tale che i lati del profilato vengano premuti accuratamente contro la troncatrice per mezzo di pistoni. Il profilato deve essere fissato in modo tale che non abbia la tendenza di spostarsi o stortarsi.

esempio: Tipico serraggio di un profilato con aletta:

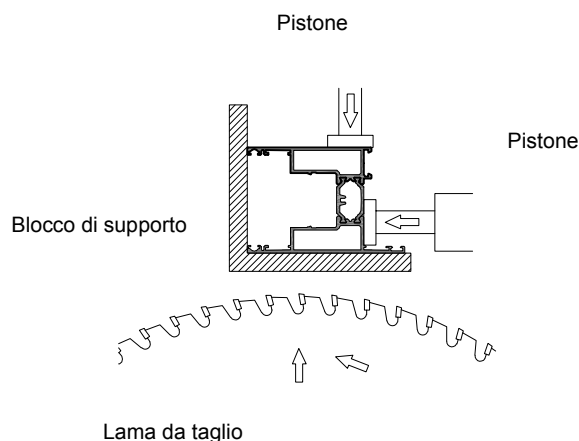

2. Punzonatura, fresatura o foratura

Dopo che i profilati sono statilavorati, le superfici devono essere sbavate, sgrassate e trattate con un prodotto anti-corrosione.

In aggiunta, l'attenzione deve essere prestata durante il trattamento, che nessun danno si verifichi sulla superficie. Questa è la causa della corrosione filiforme.

Tipici esempi di questi processi sono:

- Forature, fresature o forature per drenaggio e ventilazione
- Fresature o punzonature per assemblaggio profilati
- Forature per il fissaggio dei profilati
- ...

3. Accoppiamenti profilati

I tagli e i cavallotti devono essere sigillati a fondo con sigillante neutro approvato, in modo tale che i requisiti di tenuta all'aria e impermeabilità siano soddisfatti.

Imponendo i necessari requisiti per l'accoppiamento del profilato, viene fatta una distinzione tra:

- Profilati pre-assemblati finestre/porte/costruzioni in alluminio:

Le sigillature sui lati visibili non possono essere più grandi di 0,3 millimetri. La disuguaglianza di connessione profilati misurata sulle superficie di costruzione presso le giunzioni e connessioni a T, non può essere superiore alla tolleranza di estrusione come descritto nella norma EN 12020.

Come conseguenza della irregolarità (concavità e convessità) dei profilati, non è sempre possibile soddisfare i requisiti dovuti alla disuguaglianza della connessione profilati; perché questa differenza non può essere superiore a 0,5 mm.

Appartenenti a questo gruppo sono i profilati per la finitura delle finestre: profilati montanti, finitura stipite, adattatori, davanzali su telaio, ... Questi hanno bisogno di essere sempre sigillati per tenuta all'aria e all'acqua con un sigillante neutro ed elastico. Per alcuni dei sigillanti specifici, vedere i dettagli rilevanti nel catalogo.

- Connessioni profilati per parti collegate durante la costruzione.

Questi trattengono parti in vetro, parti pannellate e parti di costruzione collegate durante la costruzione. Con questi, gli interspazi e connessioni tra profilati dovranno essere scelti in modo tale che con differenze di temperatura il loro funzionamento sarà indisturbato.

I giunti tra travi orizzontali e verticali di facciate in vetro non possono essere più grande di 2mm, escluse le tolleranze profilati, giunti più grandi devono essere sigillati con un prodotti adeguati. Appartenenti a questo gruppo sono i profilati necessari al completamento dell'intera costruzione: montanti d'angolo, cornici collegate, profilati di rinforzo, come collegare i profili, Questi devono essere sempre sigillato per tenuta aria e per evitare infiltrazioni d'acqua.

4. Drenaggio

È importante evitare il più possibile infiltrazioni di acqua piovana nelle scanalature. L'acqua trasporta lo sporco, che andranno a formare depositi nelle cavità. Sporczia e acqua mettono a dura prova guarnizioni e trattamenti superficiali.

Misure per prevenire l'infiltrazione di acqua piovana:

- Tagli e connessioni di travi verticali su travi orizzontali, nonché la reciproca connessione con la vetratura - e le gomme di tenuta, necessitano avere un appropriato, dove necessario elastico, sigillante per evitare la penetrazione di acqua piovana.
- Per evitare che l'acqua piovana venga ritenuta nelle finestre, la pressione dell'aria nelle cavità deve essere uguale alla pressione atmosferica esterna, cosiddetta equalizzazione della pressione. Pertanto, le cavità devono avere aperture che vanno rifinite il più possibile ermeticamente verso l'interno. Per ulteriori dettagli, vedi più avanti nel catalogo.
- Utilizzare gli schemi per scarico acqua prescritti al fine di garantire un buon drenaggio.
- Rispettare la distanza regolare tra i fori di drenaggio. Per dettagli sul posizionamento, vedere più avanti nel catalogo.
- Lo scarico di drenaggio tra il telaio fisso e la parte apribile deve avere una distanza minima vicino agli angoli, con una superficie almeno di 50 mm² per apertura, sia se si tratta di fori tondi con un diametro minimo di 8 mm, o una asola da 5mm per 15mm. (la norma provvisoria prEN 12488 prevede 20 mm).
- Con finestre a ghigliottina, porte e facciate continue, il drenaggio può deviare dalla suddetta regola, seguendo, le regole imposte dal proprietario del sistema.

5. Guarnizioni

Le guarnizioni per vetratura, guarnizioni di tenuta all'acqua o all'aria e anche di tenuta acustica, sono normalmente prodotte in EPDM, TPE (gomme termoplastiche) o gomme siliconiche.

Le giunzioni di queste guarnizioni possono essere realizzate come segue:

- Incollaggio con adesivi compatibili.
- Telai vulcanizzati o angoli vulcanizzati.
- Guarnizioni continue.

Le guarnizioni dovranno essere installate prevedendo una lunghezza extra per ritiro: $\pm 1\%$.

6. Installazione della vetratura

Il buon funzionamento della finestra dipende dalla corretto inserimento della vetratura. Il posizionamento dipende dal tipo di finestra.

Vanno utilizzati i prescritti supporti vetro, che sono particolarmente adatti e su misura per le specifiche serie.



DIRETTIVE GENERALI

7. Fissaggio telai

Il fissaggio (staffe finestre, tappi, etc...) sono necessari in numero tale da resistere alla normale pressione dell'aria e qualsiasi altro carico possibile con un coefficiente di sicurezza 3, senza deformazioni permanenti.

Essi saranno posizionati ad una distanza massima di 750 mm tra di loro e circa a 200 mm di distanza da ogni angolo o trave del telaio fisso.

Con le presenza di parti apribili di finestre o porte, il fissaggio dovrà essere posizionato vicino al punto, raccomandato di apertura o chiusura..

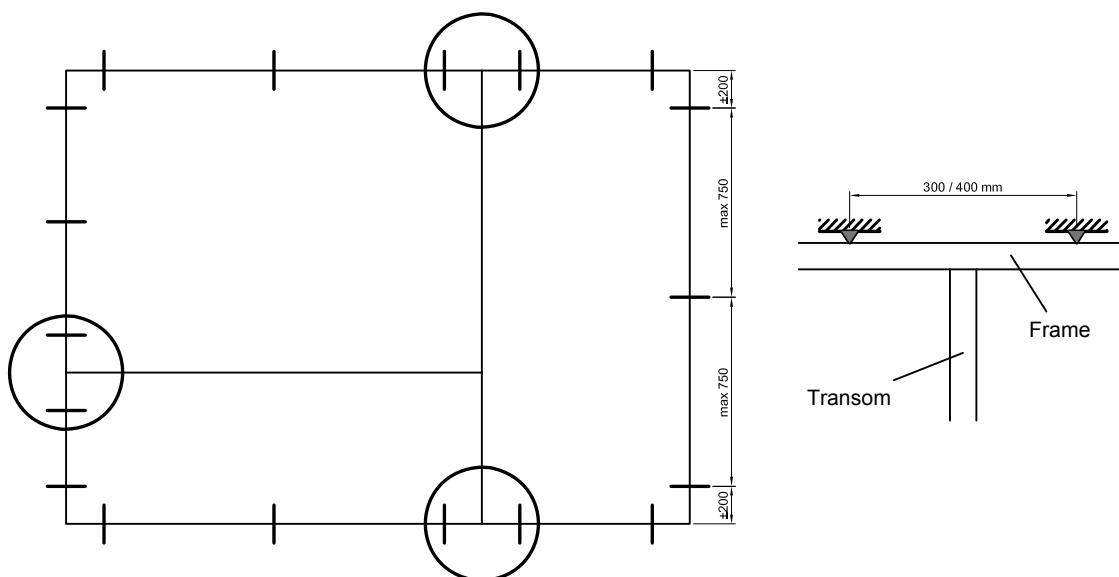

8. Contatti con altri materiali.

Se due metalli con un diverso potenziale elettrochimico sono in contatto tra loro in un ambiente umido, il metallo meno prezioso si corrode. Con i seguenti materiali, in particolare, saranno da prendere alcune misure preventive per evitare la corrosione: acciaio, rame, zinco e piombo.

Alcuni tipi di legni, come rovere e noce, rilasciano un tipo di acido che può danneggiare il metallo, in particolare in un ambiente umido o se il legno non è completamente essiccato. E' raccomandato in questo caso di isolare il metallo.

Gesso o cemento in aria umida o l'irrorazione di gesso o cemento hanno un impatto sulla superficie dell'alluminio, che potrà presentare segni bianchi dopo la pulizia, anche su superfici anodizzate. La protezione dell'alluminio durante la fase di costruzione sarà garantita applicando un foglio protettivo o un nastro con raccomandazione che l'adesivo non sia aggressivo. Per la finitura di intonaci interni ed esterni con la costruzione in alluminio, è consigliato l'uso di un profilato di limitazione della parte intonacata.

Altri materiali: si dovrebbe avere certezza che i materiali usati, che vengono a contatto con l'alluminio non producano reazioni chimiche con l'alluminio e con lo strato protettivo (trattamenti superficiali).

9. Profilati plastici

Tutti i profilati plastici deve essere conservati per almeno 24 ore a una temperatura ambiente di almeno + 15 ° C prima di essere utilizzati. Potrebbero esserci eventuali danni e rotture dovute alla fragilità del materiale se freddo.

DRENAGGIO "LATO BAGNATO"

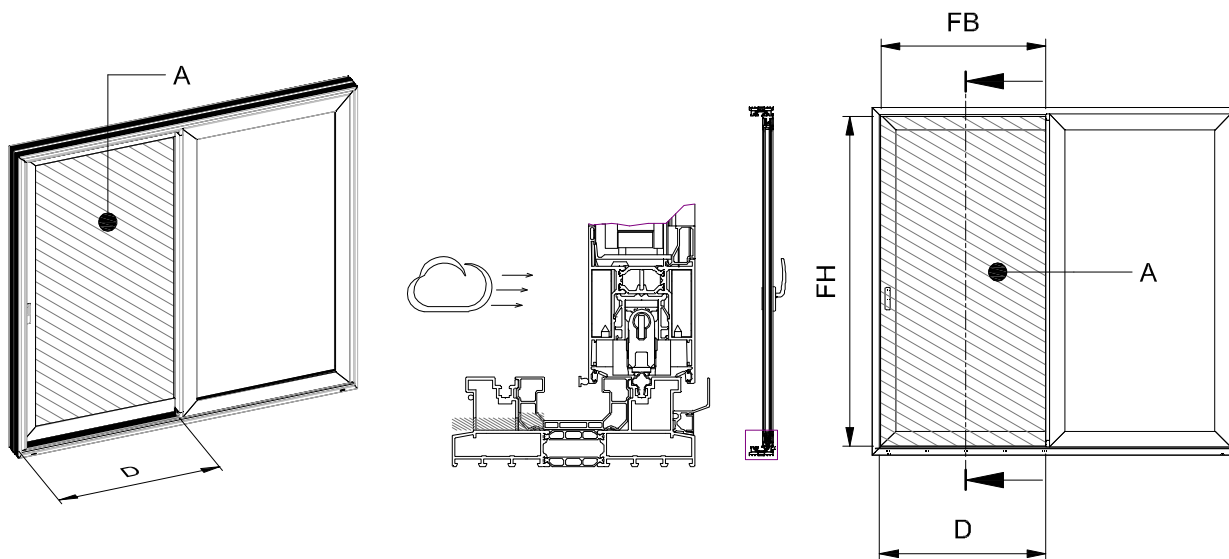

$$A \text{ (m}^2\text{)} = FB \times FH = N$$

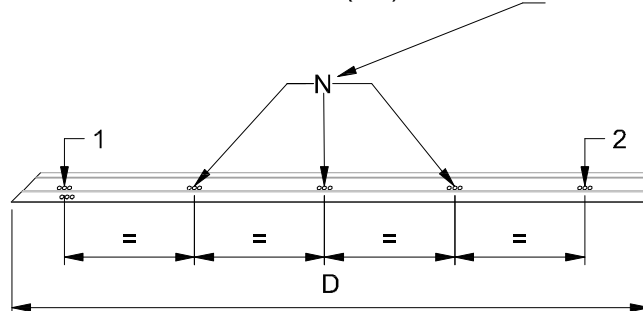
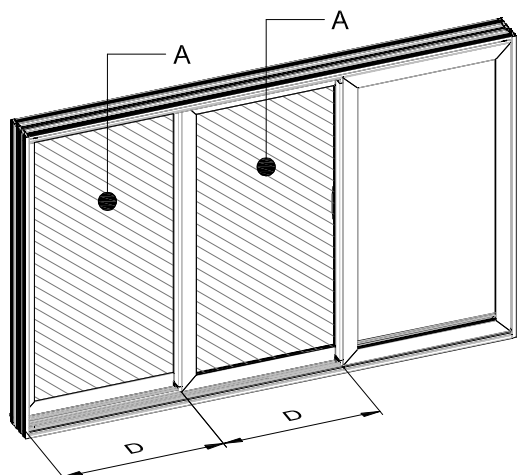

Glossario:

- D: lunghezza gocciolatoio esposto alle intemperie, necessità drenaggio
- A: superficie anta esposta alle intemperie in m²
- N: numero di scarichi aggiuntivi, ad intervallo equidistante tra scarichi 1 and 2. N = valore arrotondato di A

Esempio:

A = 2,4 m² → N = 2 → numero totale di scarichi per anta = 4

A = 2,6 m² → N = 3 → numero totale di scarichi per anta = 5

Vedi:

J.2.9 J.2.14

J.2.8

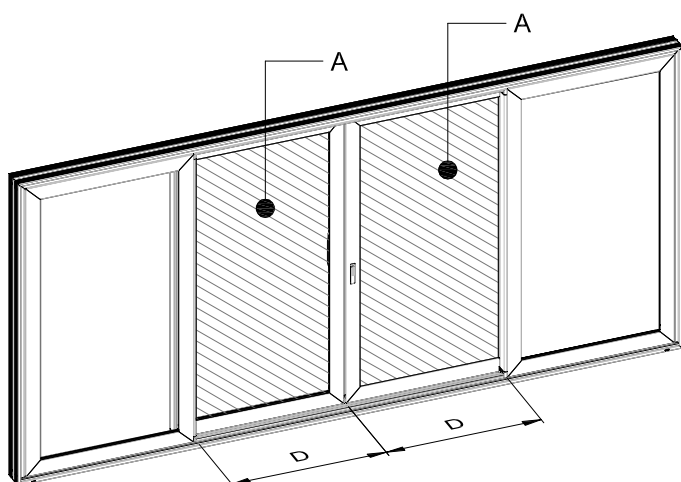



DIRETTIVE GENERALI

DIRETTIVE GENERALI PER VITI E CLIPS

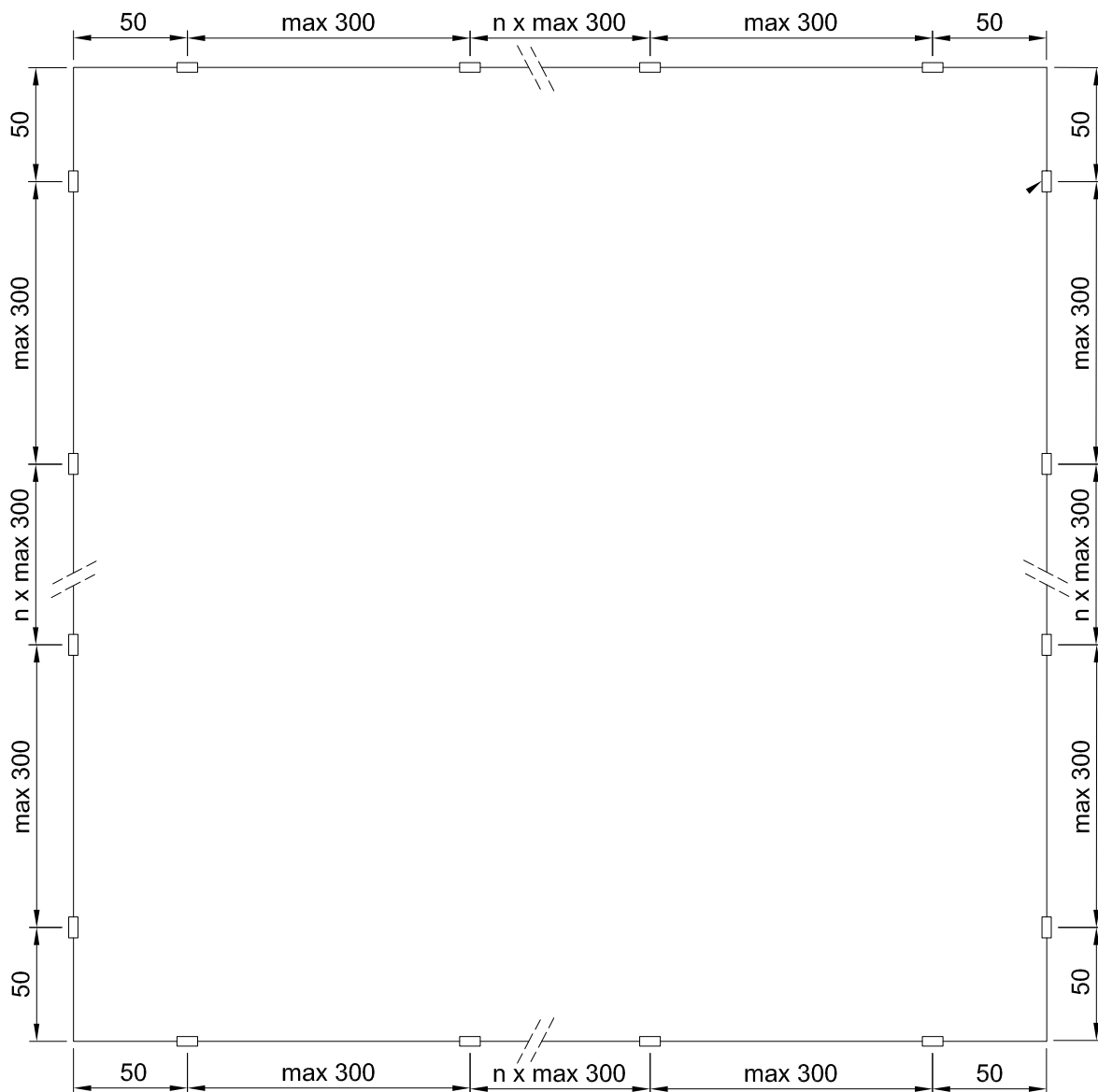

CO2279

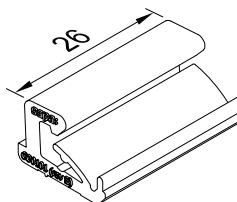

CO0101

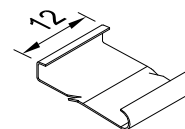

71C030



FERRAMENTA & DISEGNI ASSEMBLAGGIO

DIRETTIVE GENERALI



1-BINARIO (C9K010) TELAIO

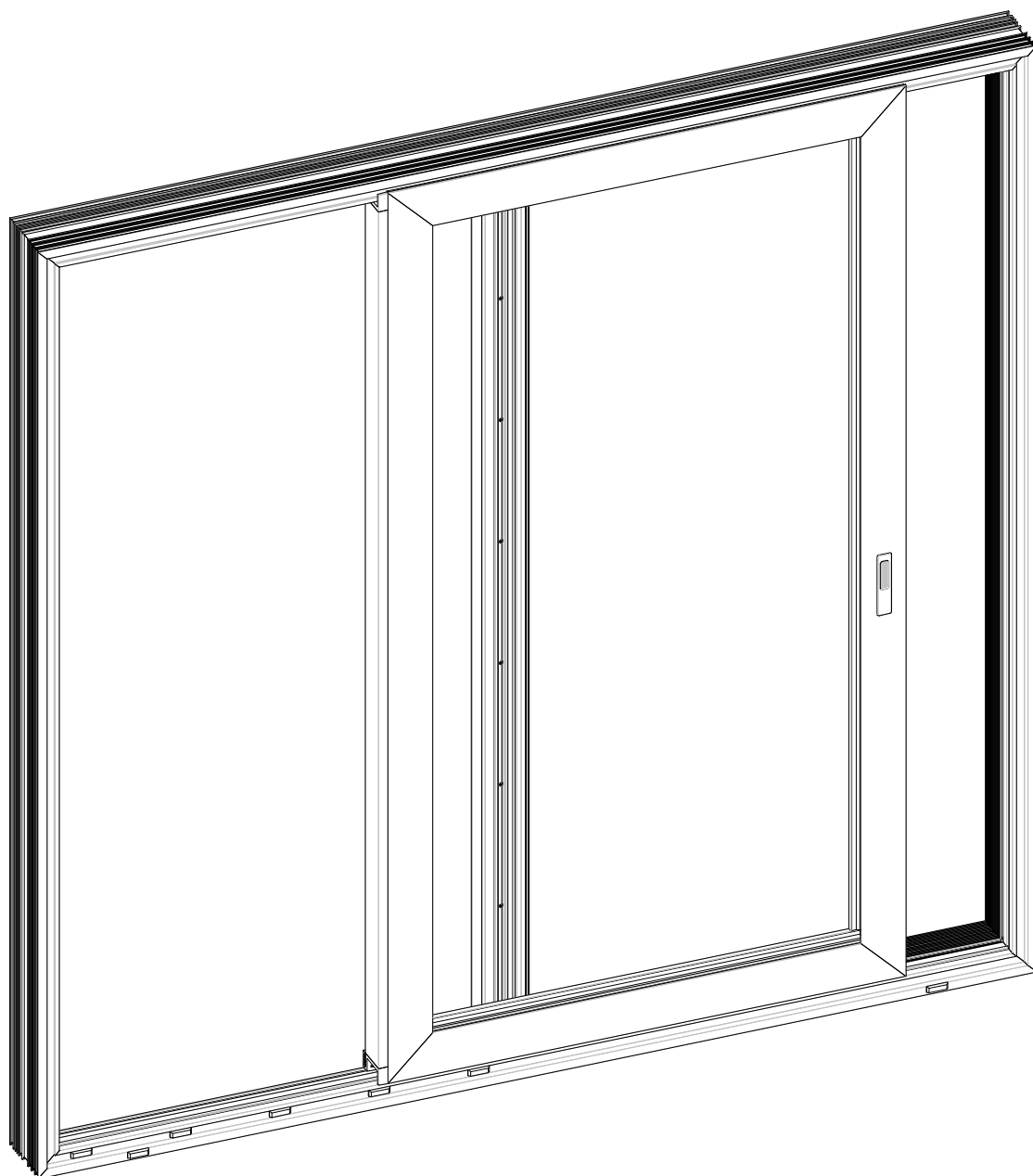
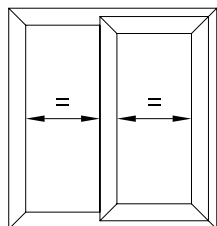

1-BINARIO (C9K010) TELAIO

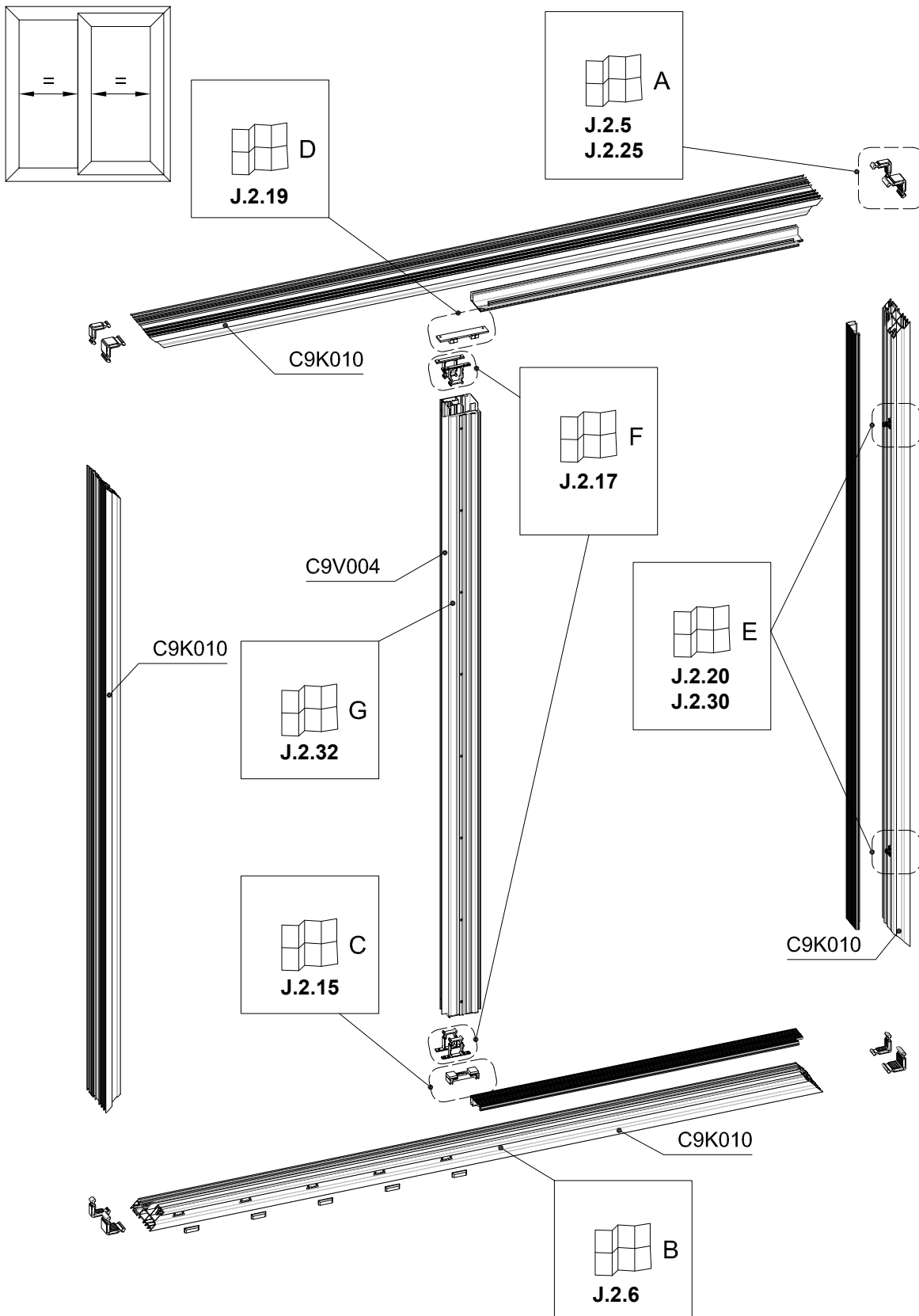



1-BINARIO (C9K010) TELAIO

CONTENUTO

1-binario (C9K010) telaio.....	J.3.1
Contenuto.....	J.3.3



Taglio del C9K010 e installazione BT6000.....	J.3.4
Lavorazione del C9K010 per inserimento squadrette.....	J.3.5



C9K010 panoramica drenaggi.....	J.3.6
C9K010 lavorazione drenaggio - J.....	J.3.7
C9K010 lavorazione drenaggio - H.....	J.3.8
C9K010 lavorazione drenaggio - B.....	J.3.9
C9K010 lavorazione drenaggio - A.....	J.3.10
C9K010 lavorazione drenaggio - G.....	J.3.11
C9K010 lavorazione drenaggio - F.....	J.3.12



Installazione VS0107.....	J.3.14
Tappo tenuta centrale CO1116 sul profilato inferiore, alzante-scorrevole.....	J.3.15
Sigillatura profilato inferiore con tappi VS9951, VS9958 e VS9959.....	J.3.16
Lavorazione del C9K010 per cavallotti su montante.....	J.3.17
Lavorazione del C9K010 per cavallotti su montante - schema 4 ante.....	J.3.18
Tappo tenuta centrale CO1114 sul profilato superiore, alzante-scorrevole.....	J.3.19
Installazione punti di chiusura -alzante-scorrevole (ZB0034/ZB0035/ZB0036).....	J.3.20
Installazione cavallotti TS3M03 e TS3M04.....	J.3.23
Installazione e sigillatura montante interno.....	J.3.24
Installazione e sigillatura montante interno - TS9Z05.....	J.3.26



Assemblaggio profilato telaio con squadrette.....	J.3.27
Assemblaggio profilato telaio con squadrette.....	J.3.28
Assemblaggio profilato telaio con squadrette.....	J.3.29
Installazione binario CO1103.....	J.3.30
Installazione binario CO1103 e ZB0038 per schema 4 ante.....	J.3.31
Installazione punti di chiusura -alzante-scorrevole.....	J.3.32
Preparazione labirinto KU2029 + RU9095 + KU6004 + RU9703 + CO2181 + VS9148.....	J.3.34
Lavorazione addizionale labirinto su montante interno.....	J.3.35
Installazione labirinto su montante interno.....	J.3.36
Installazione RU9094 e BT6013.....	J.3.37
Preparazione e installazione cartellina C9A002.....	J.3.38

TAGLIO DEL C9K010 E INSTALLAZIONE BT6000

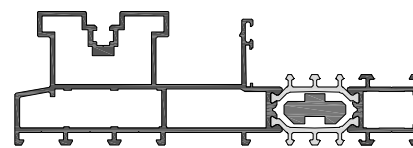
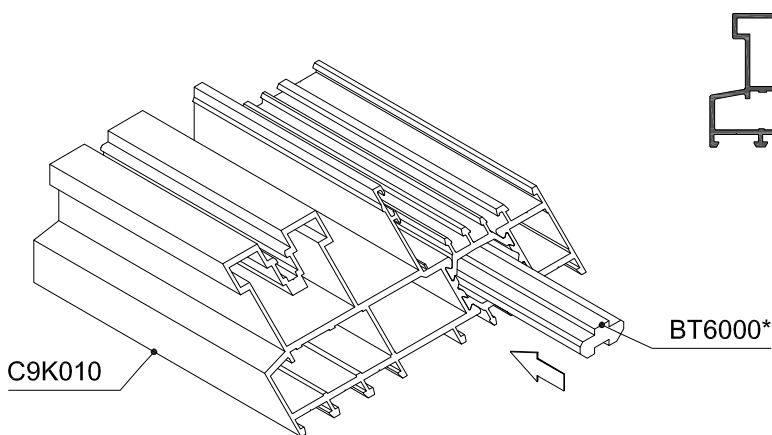
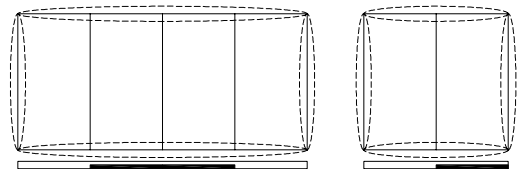
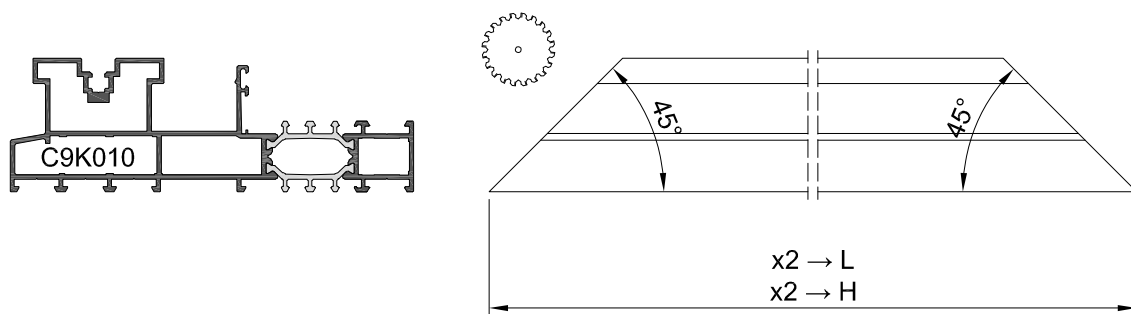
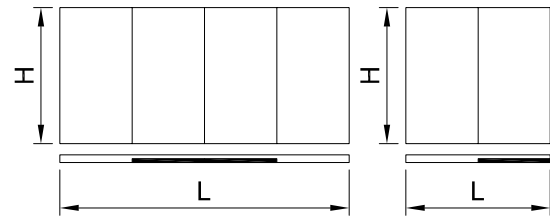

	BT6000
SHI	✓
SI	✓
I	x



1-BINARIO (C9K010) TELAIO

LAVORAZIONE DEL C9K010 PER INSERIMENTO SQUADRETTE

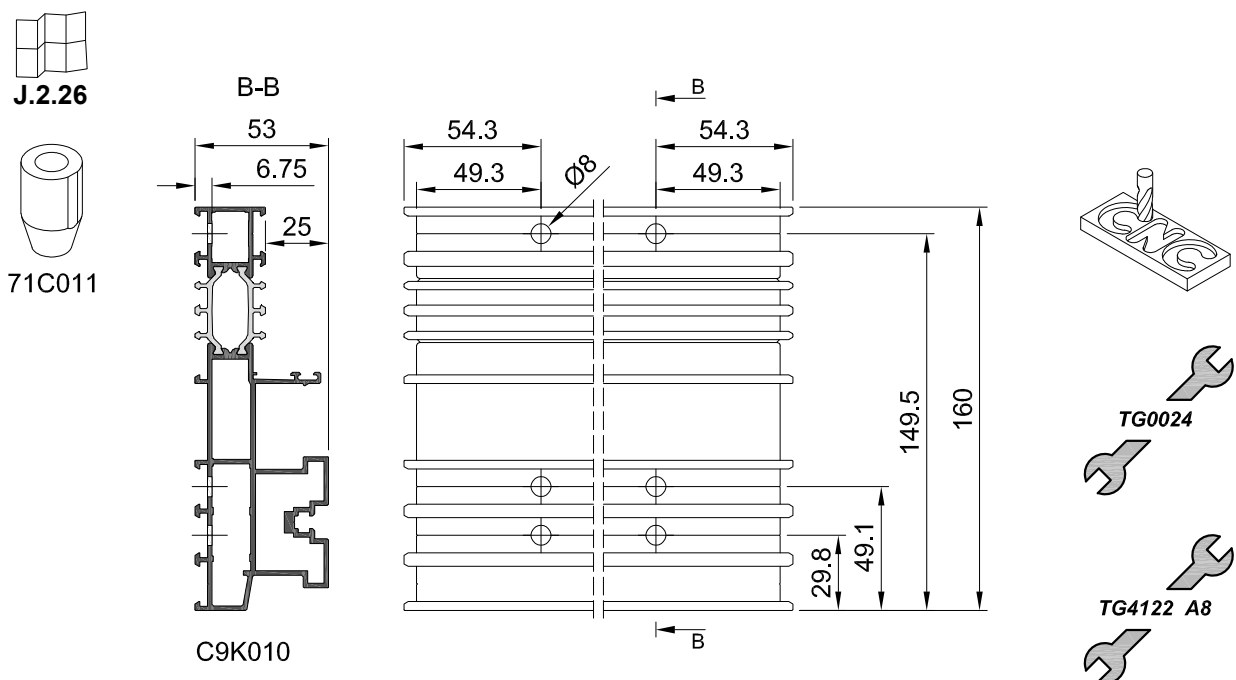
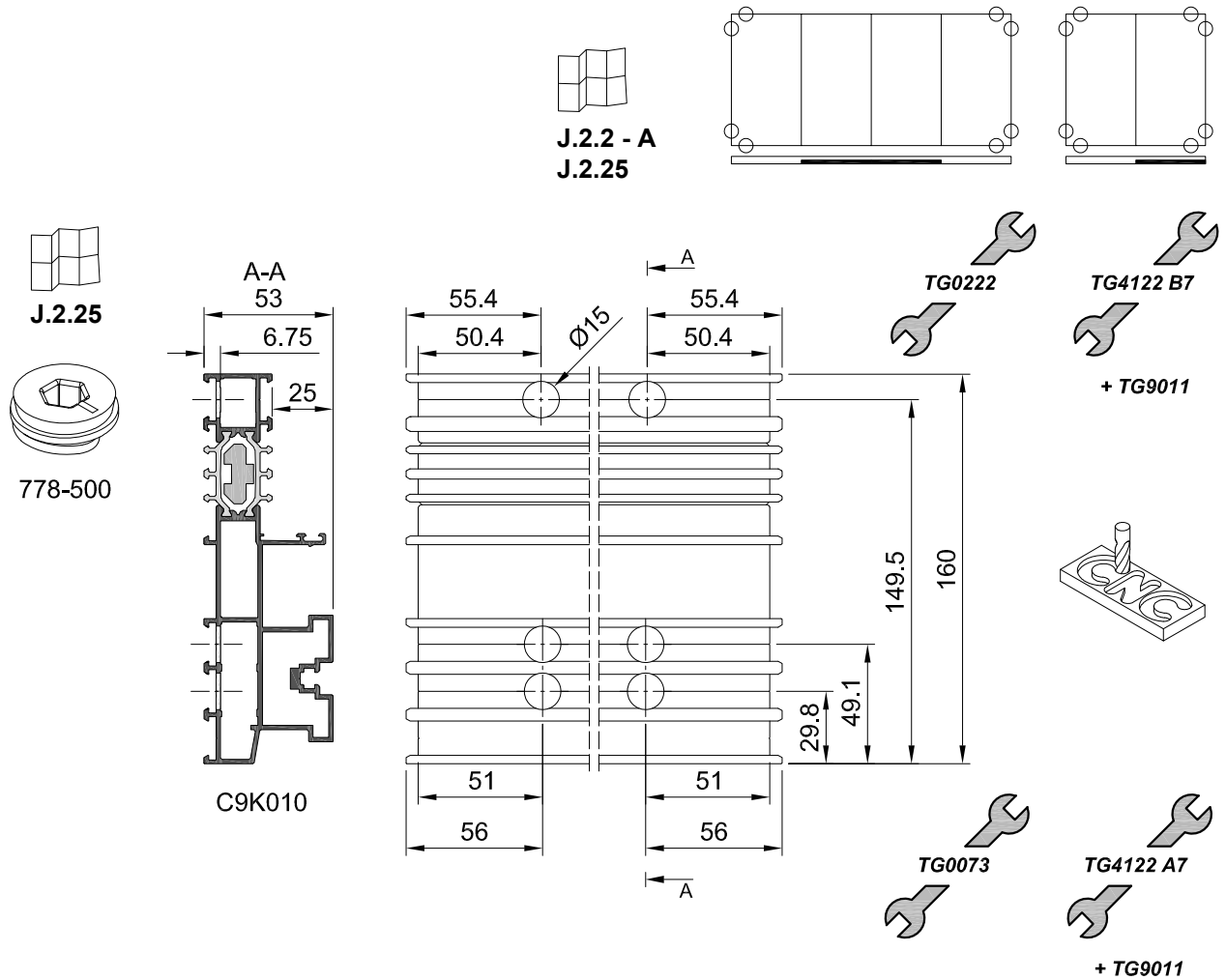

C9K010 PANORAMICA DRENAGGI

1 / 9

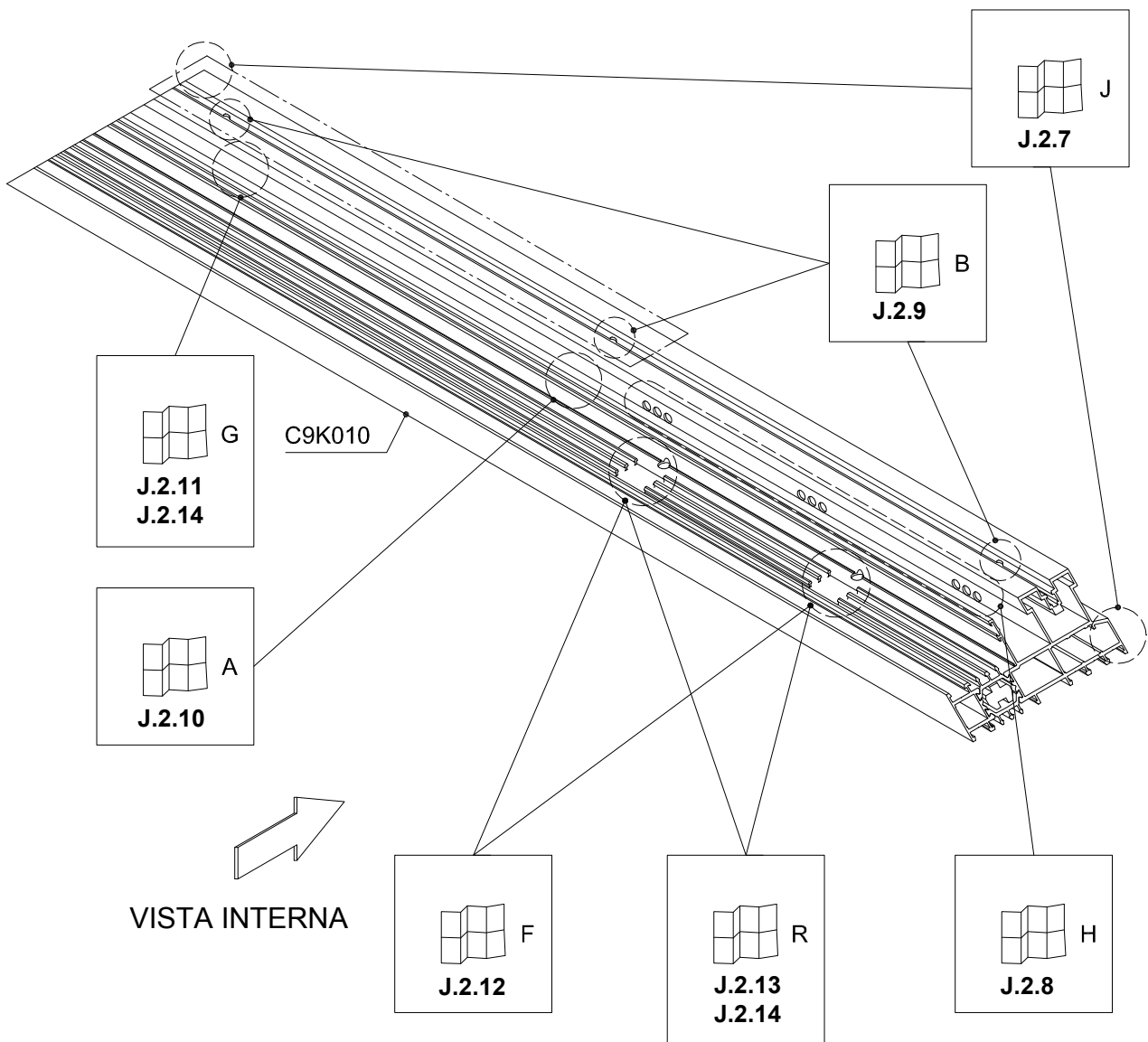
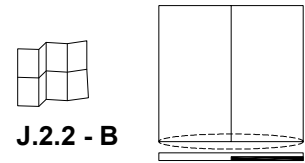



1-BINARIO (C9K010) TELAIO

C9K010 LAVORAZIONE DRENAGGIO - J

2 / 9



J.2.6 - J

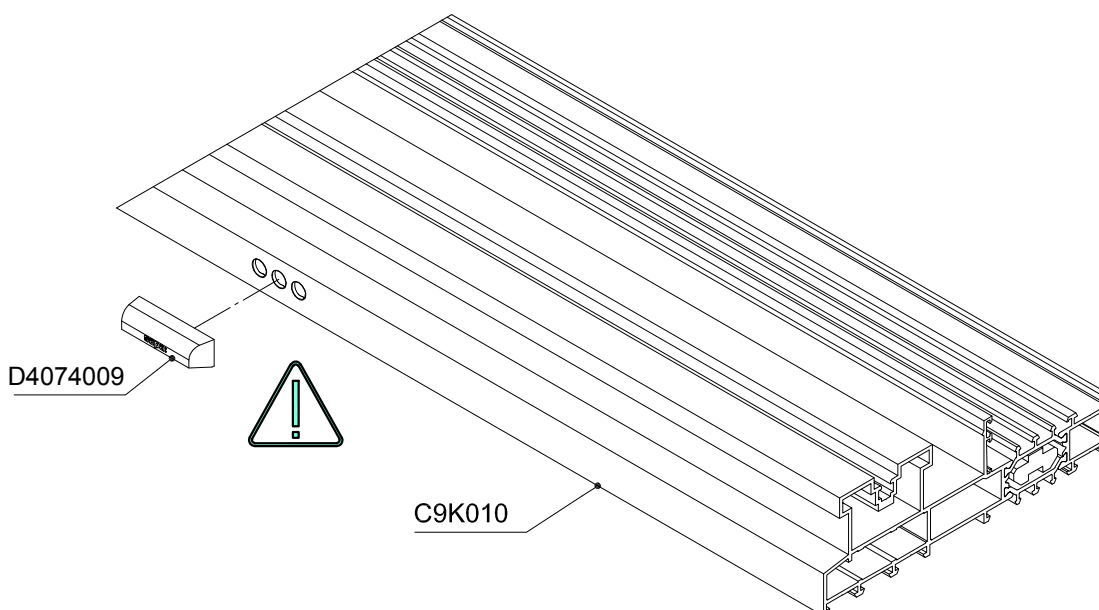
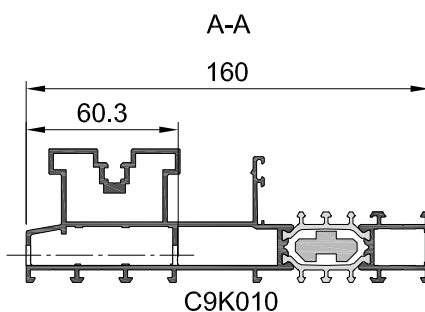
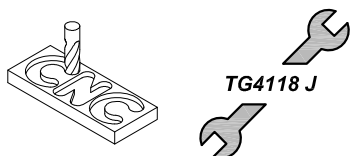
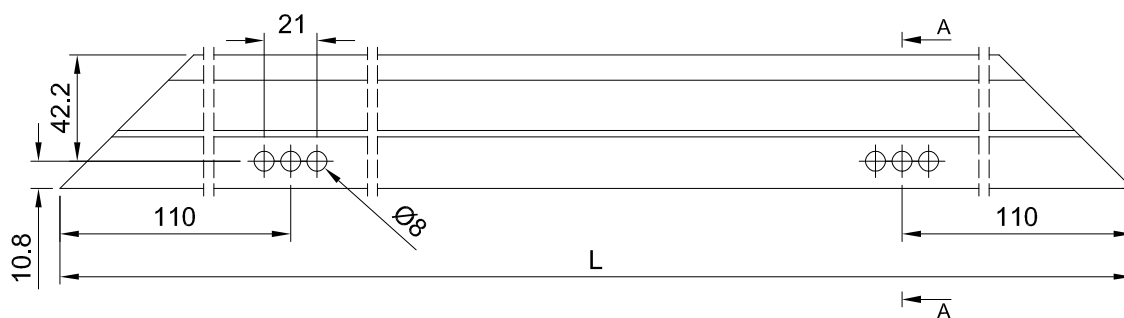
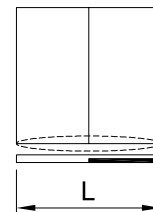

C9K010 LAVORAZIONE DRENAGGIO - H

3 / 9

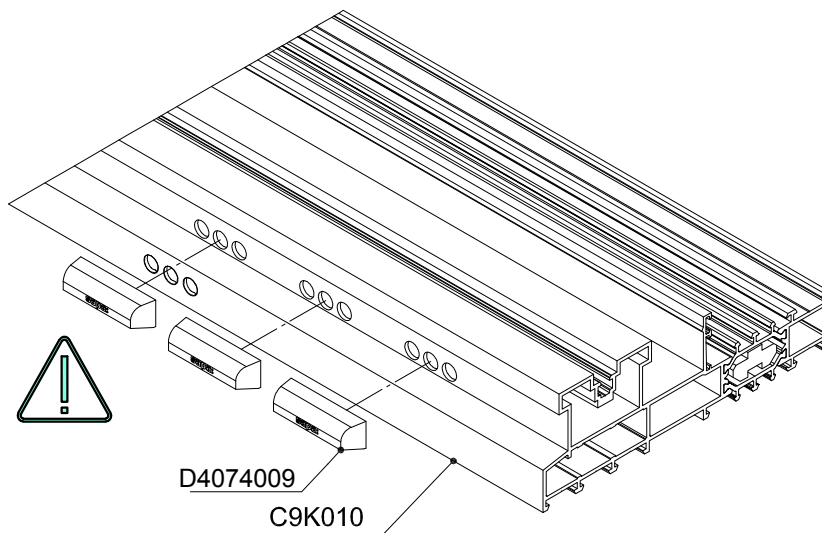
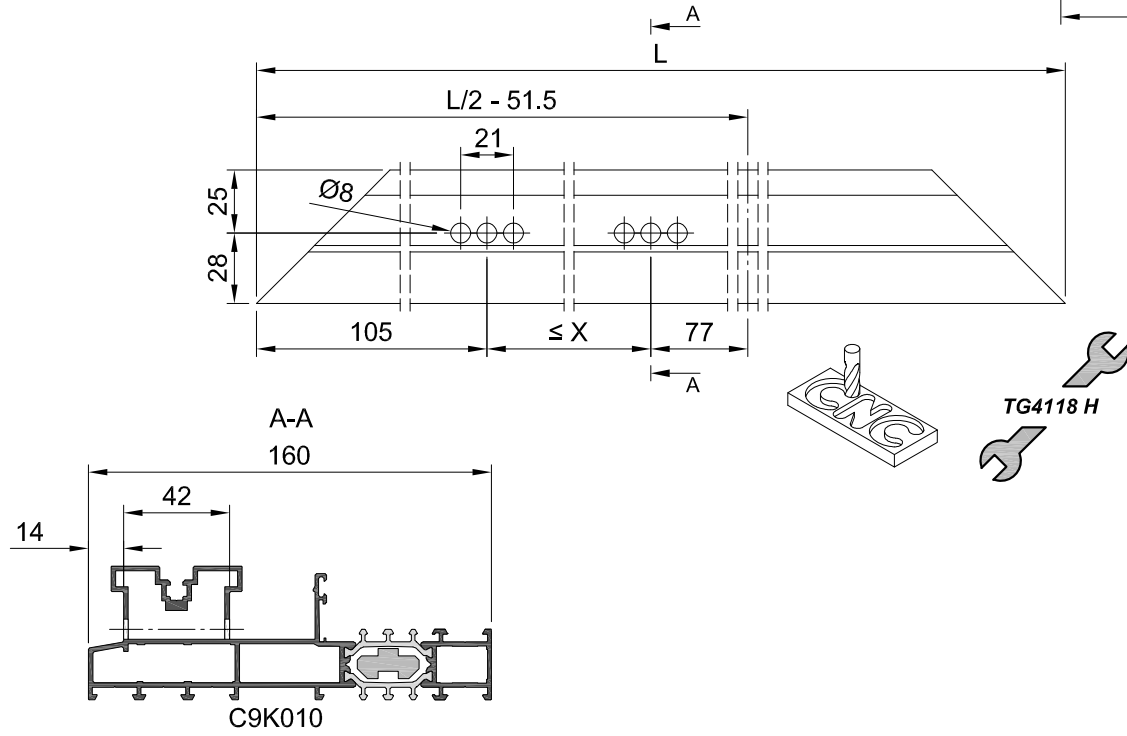
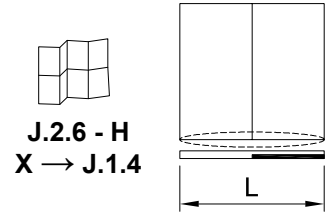



1-BINARIO (C9K010) TELAIO

C9K010 LAVORAZIONE DRENAGGIO - B

4 / 9



J.2.6 - B

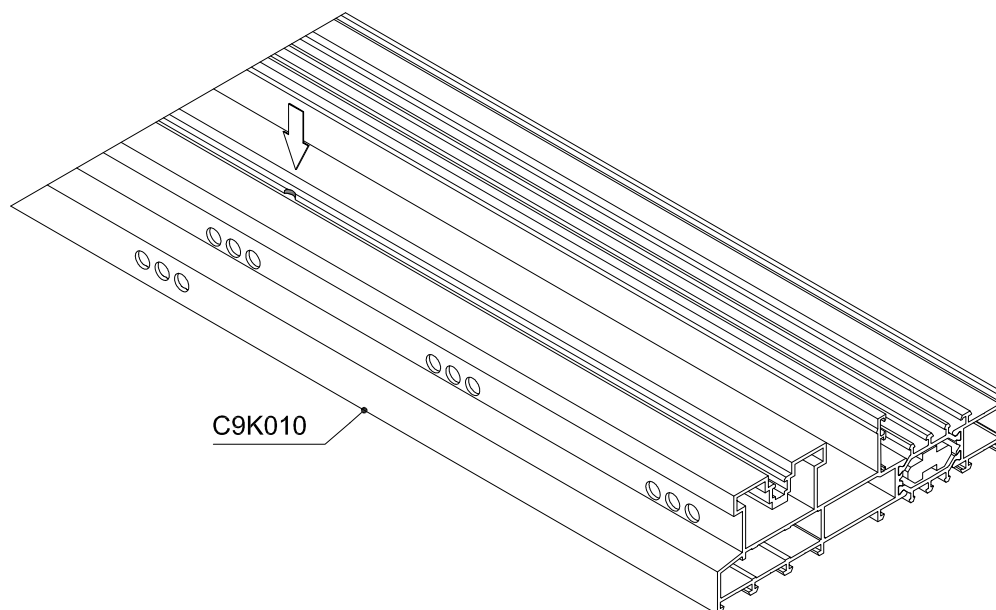
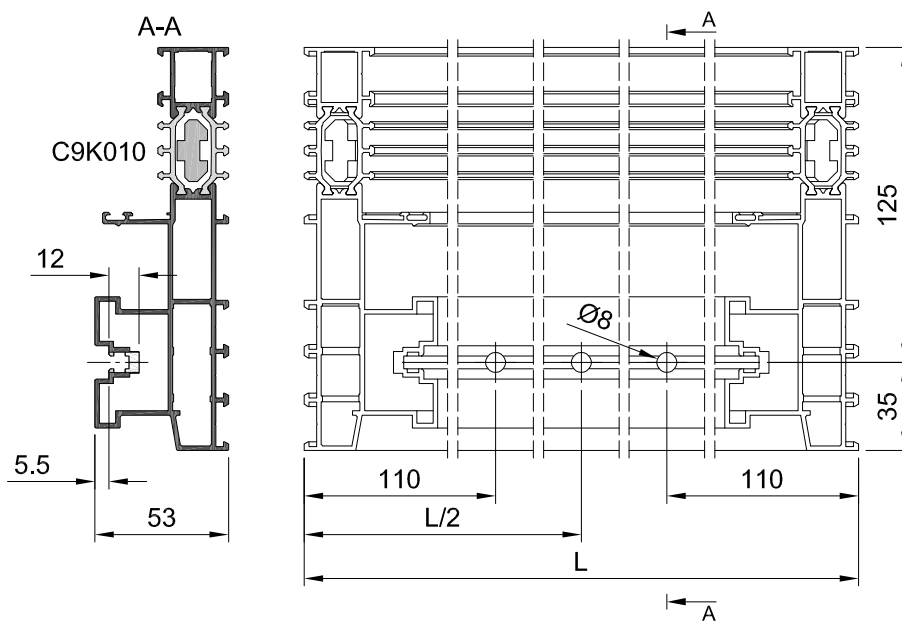
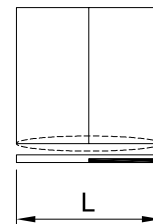

C9K010 LAVORAZIONE DRENAGGIO - A

5 / 9

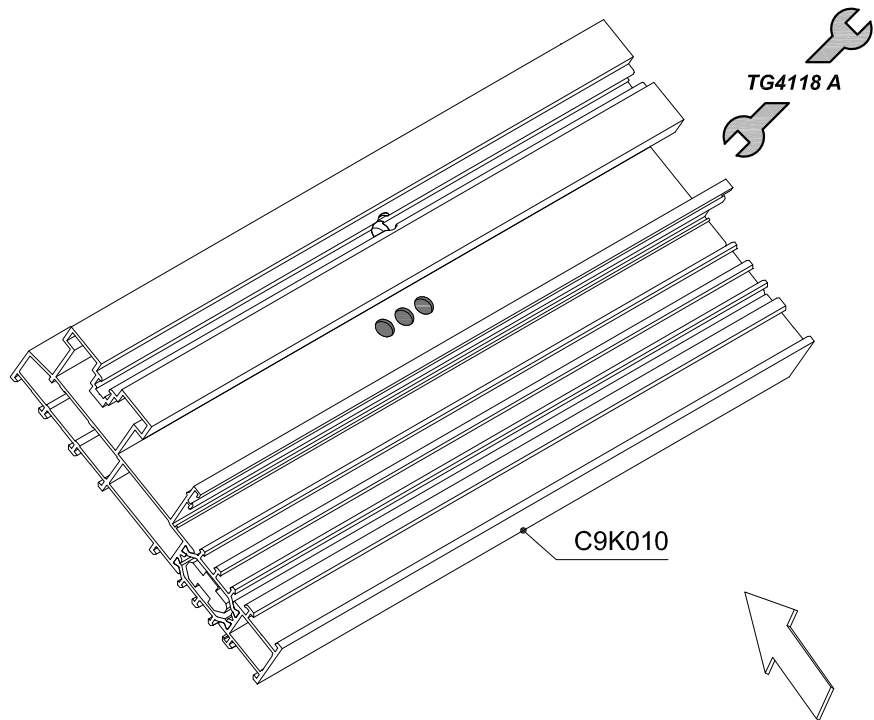
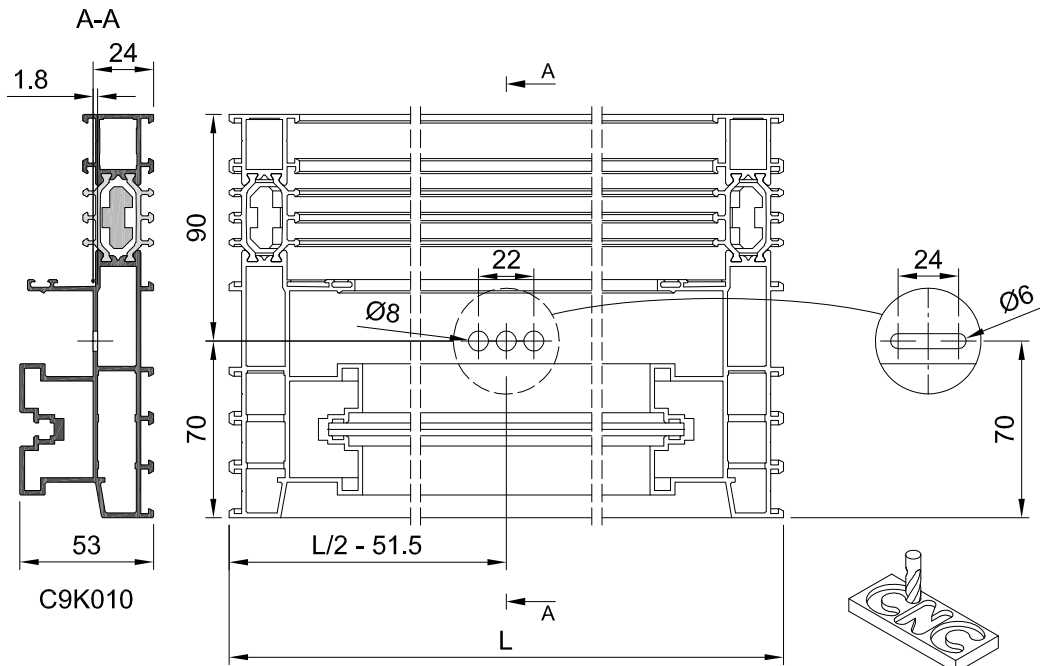
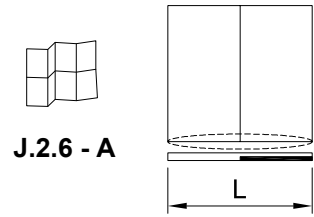

VISTA INTERNA



1-BINARIO (C9K010) TELAIO

C9K010 LAVORAZIONE DRENAGGIO - G

6 / 9



J.2.6 - G
J.2.14

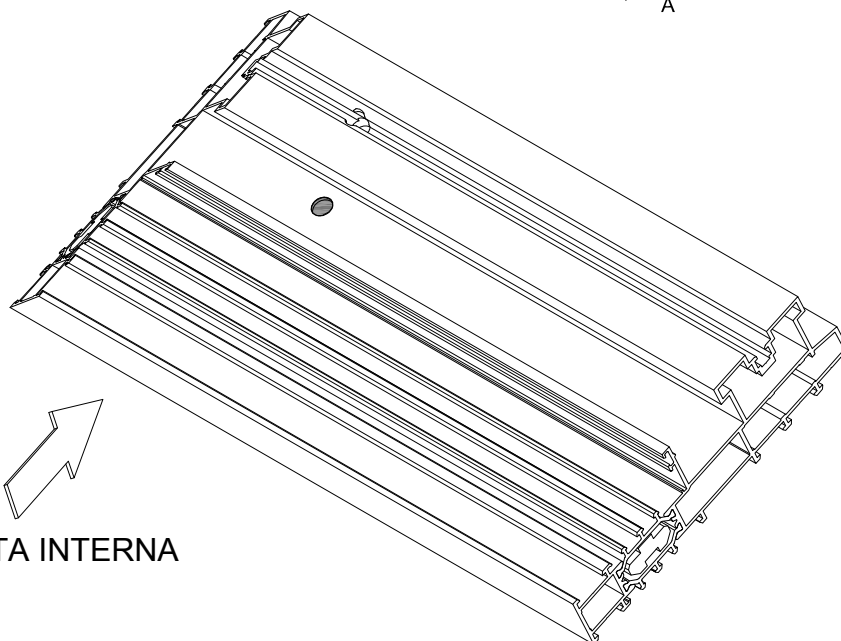
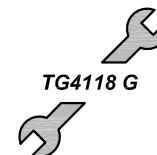
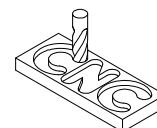
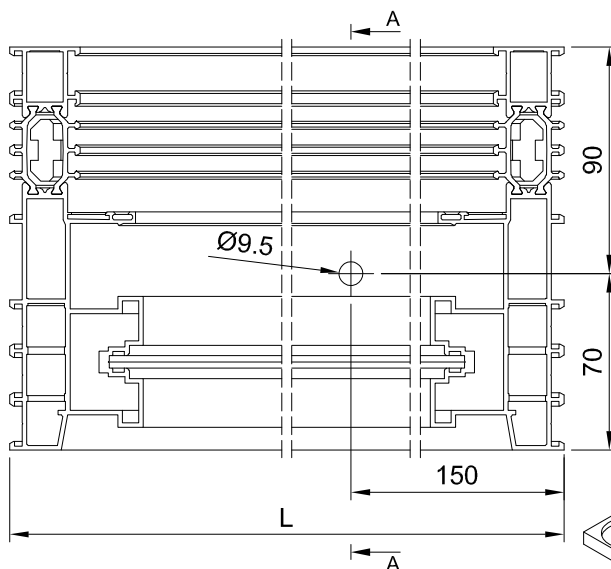
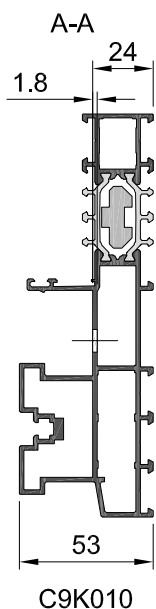
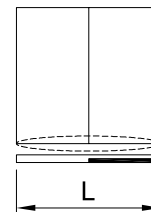

VISTA INTERNA

C160-ASS-1407

C9K010 LAVORAZIONE DRENAGGIO - F

7 / 9

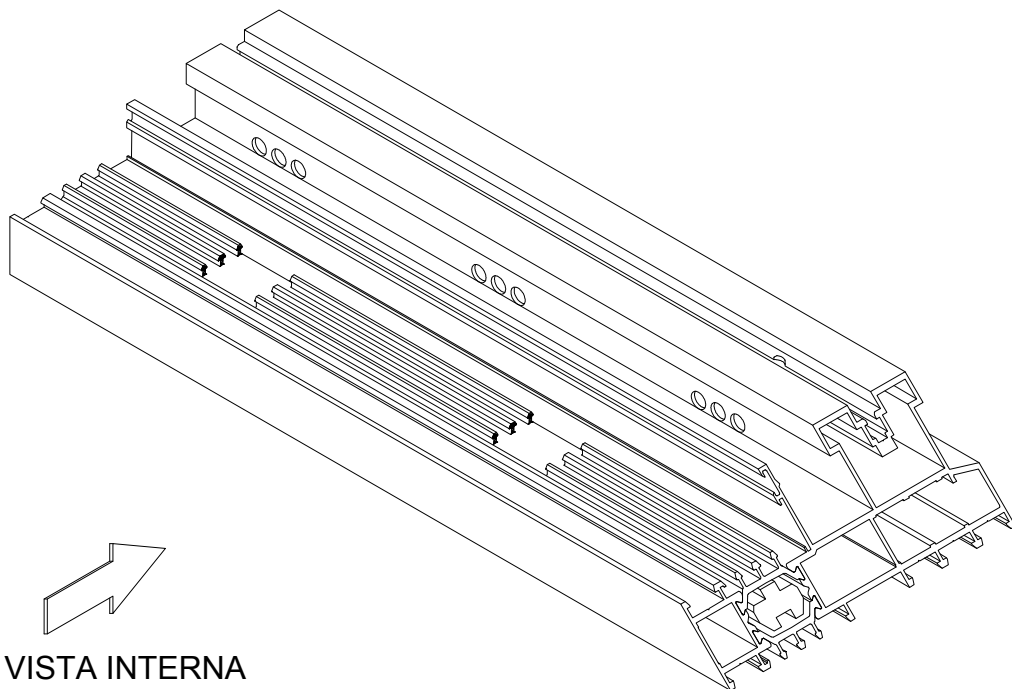
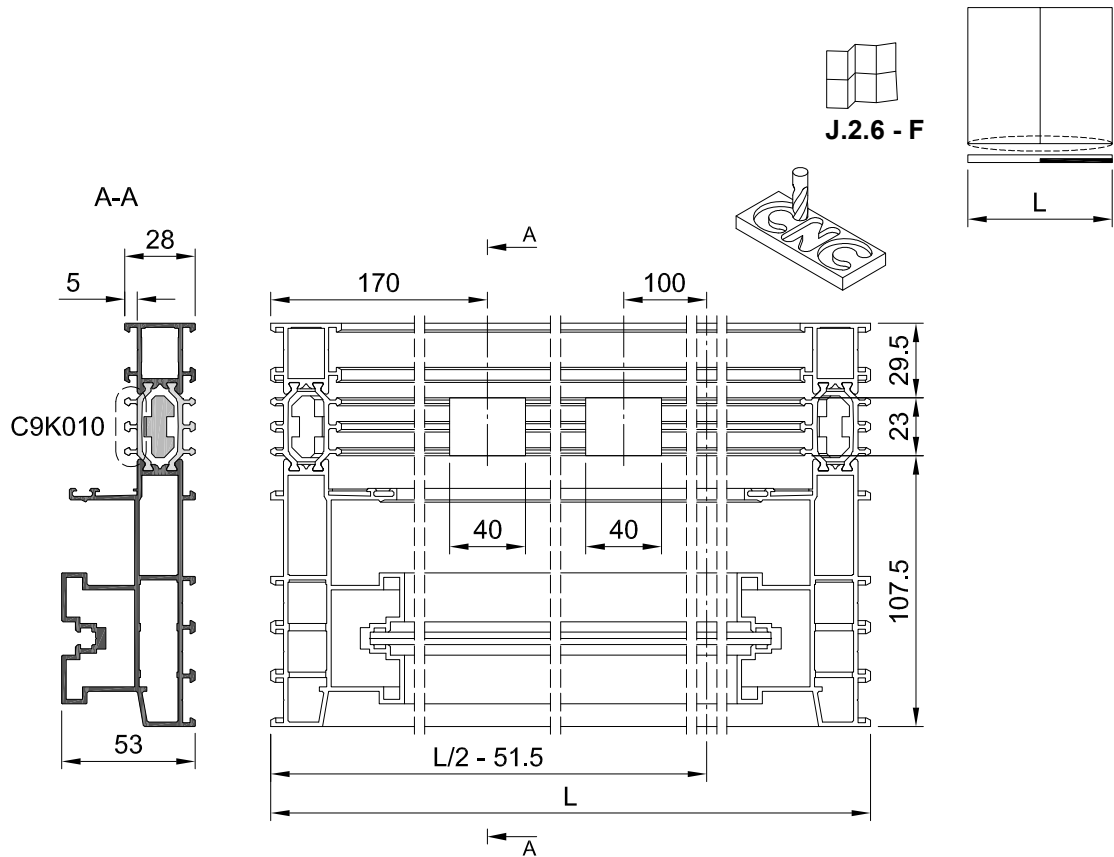



1-BINARIO (C9K010) TELAIO

C9K010 LAVORAZIONE DRENAGGIO - R

8 / 9



J.2.6 - R
J.2.14

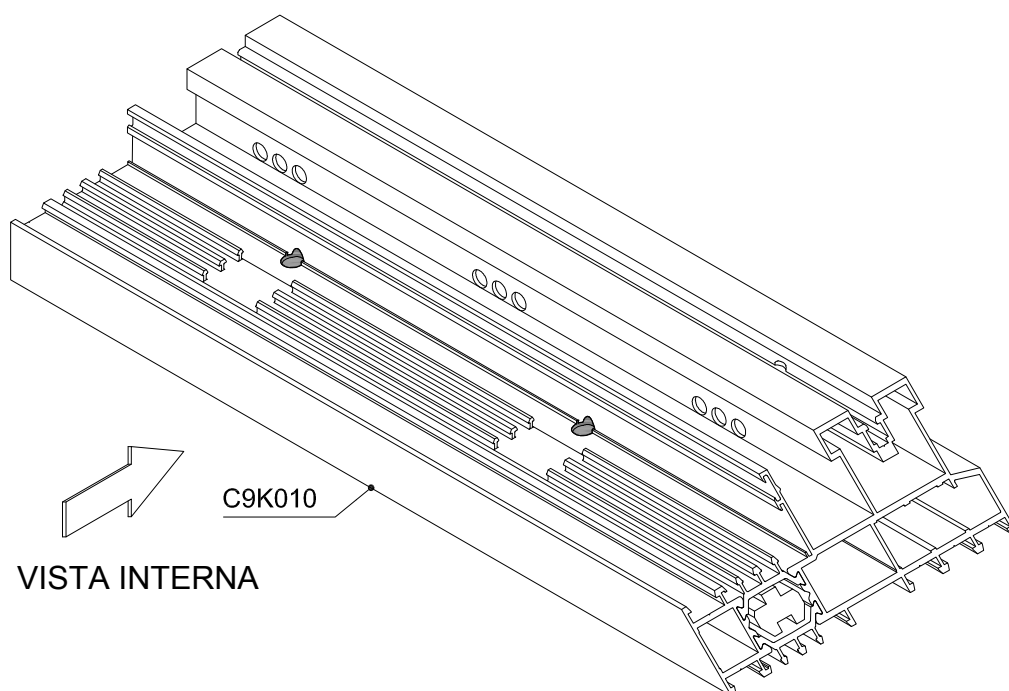
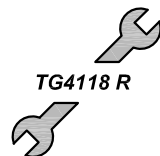
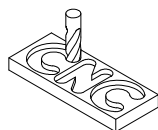
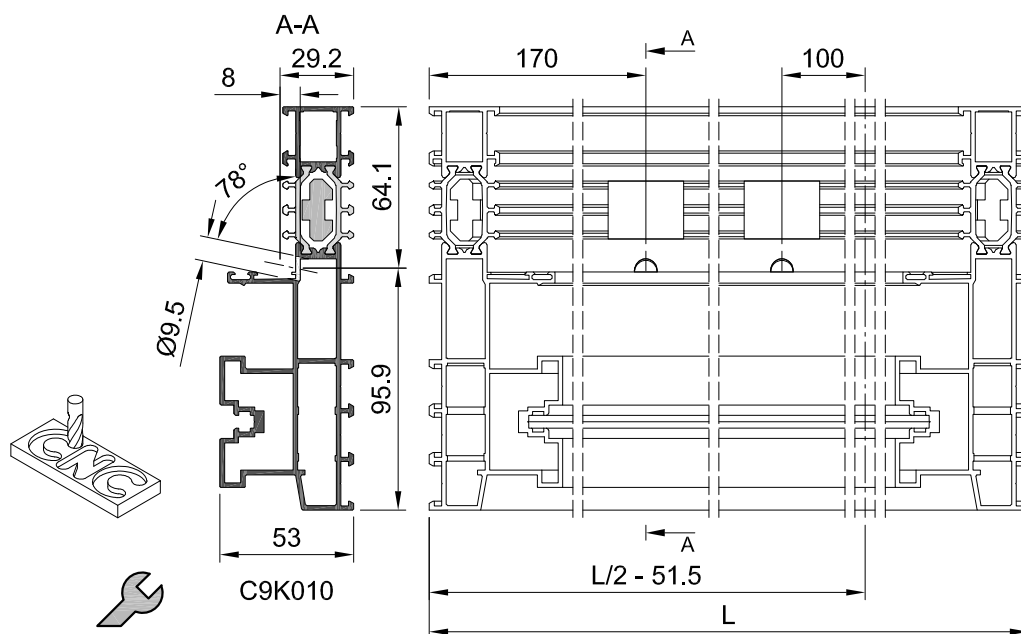
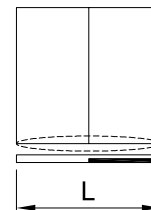

INSTALLAZIONE VS0107

9 / 9

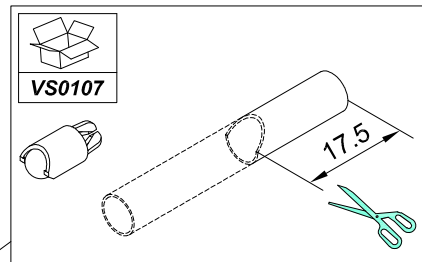
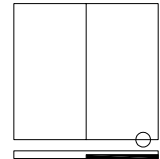

J.2.6 - E
J.2.11

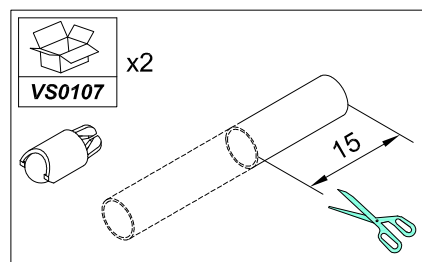
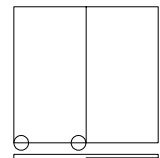
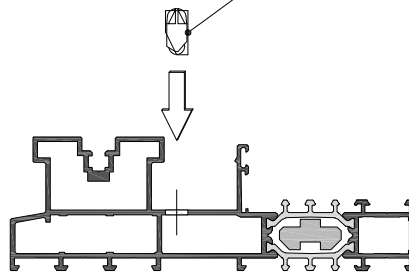

J.2.6 - F
J.2.13

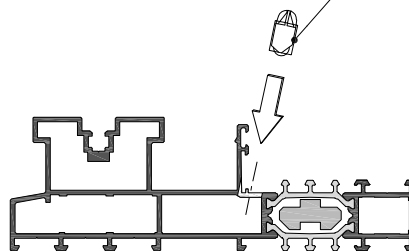



1-BINARIO (C9K010) TELAIO

TAPPO TENUTA CENTRALE CO1116 SUL PROFILATO INFERIORE, ALZANTE-SCORREVOLE



J.2.2 - C

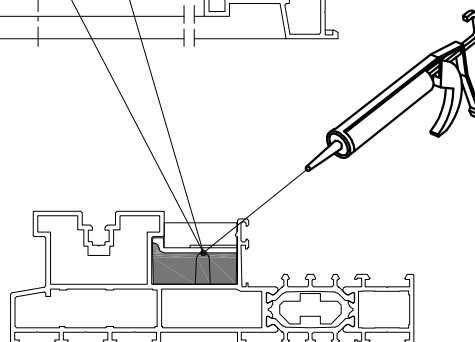
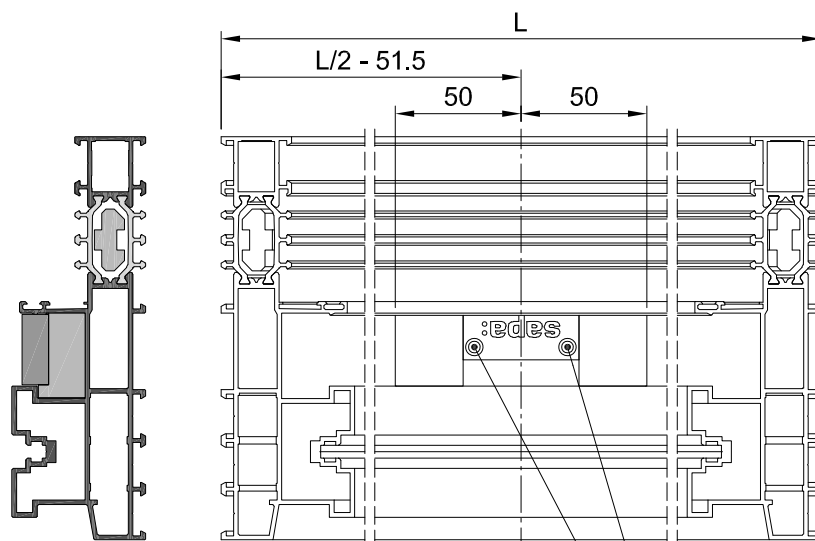
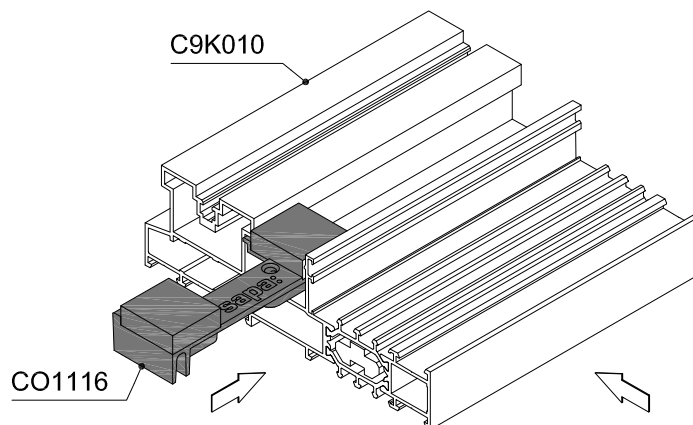
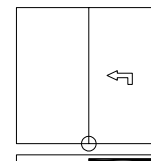

SIGILLATURA PROFILATO INFERIORE CON TAPPI VS9951, VS9958 E VS9959

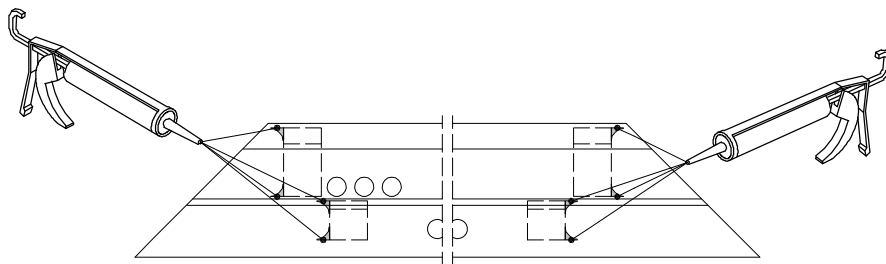
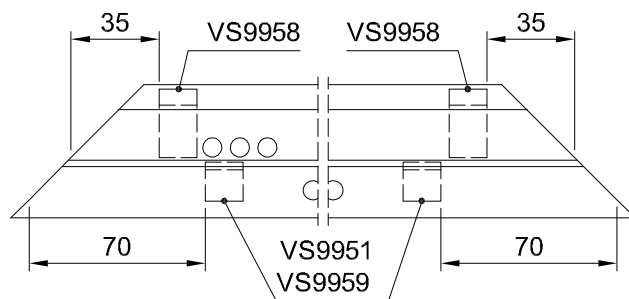
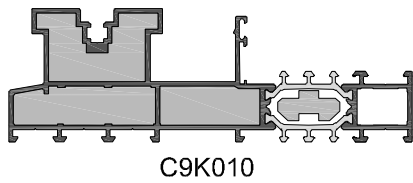
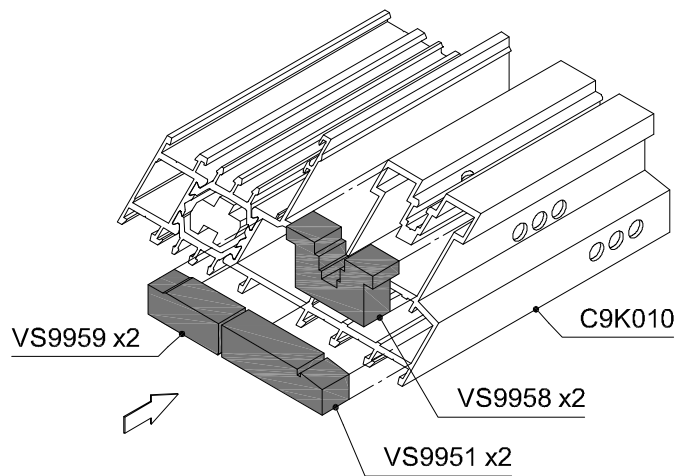
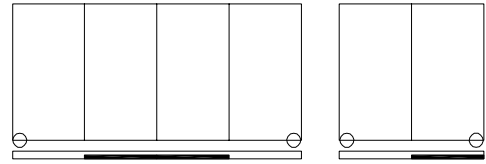



1-BINARIO (C9K010) TELAIO

LAVORAZIONE DEL C9K010 PER CAVALLOTTI SU MONTANTE

1 / 2

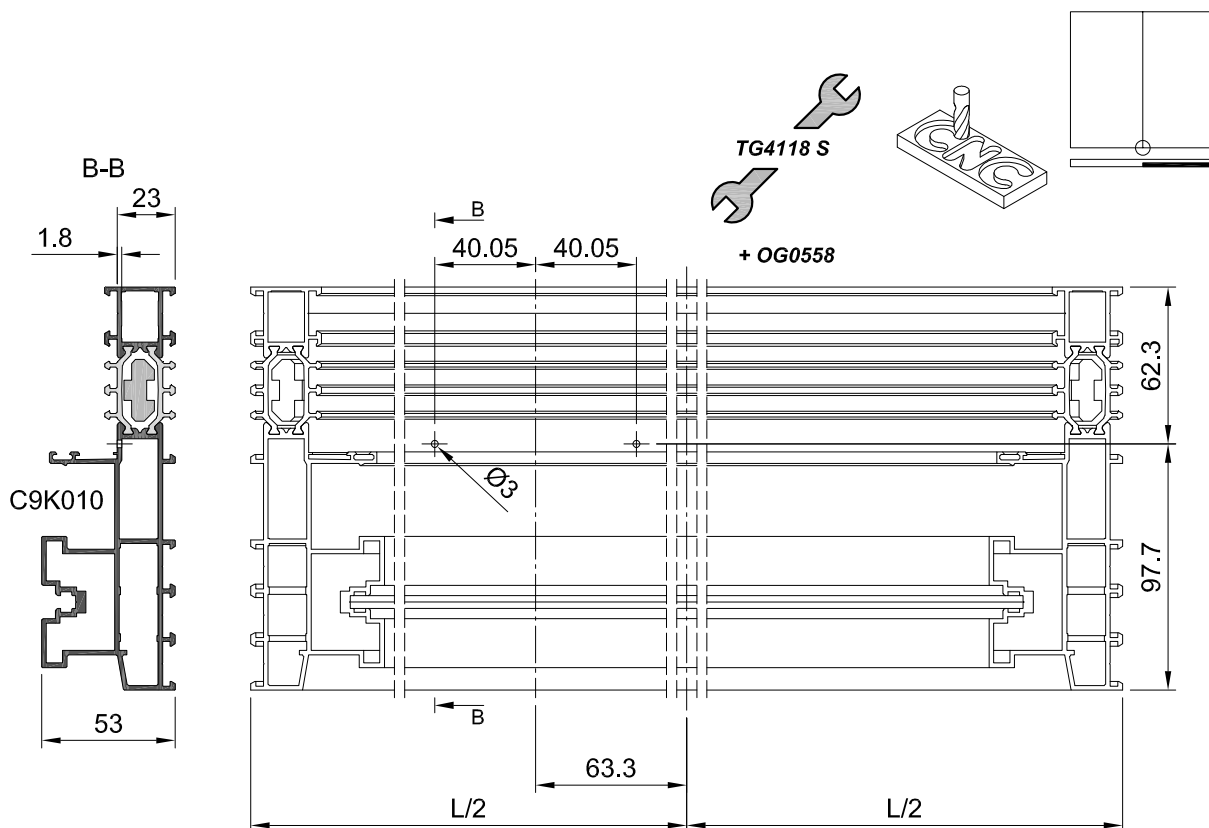
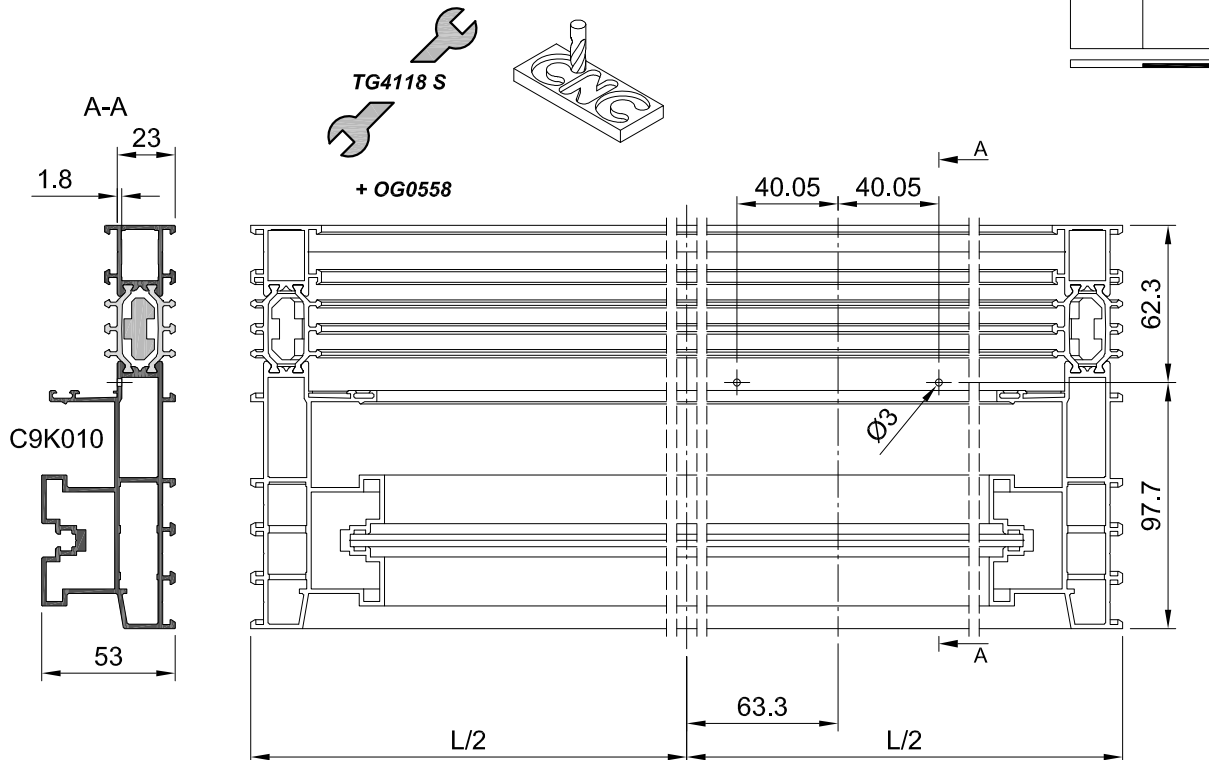

C160-ASS-1414L

LAVORAZIONE DEL C9K010 PER CAVALLOTTI SU MONTANTE - SCHEMA 4 ANTE

2 / 2

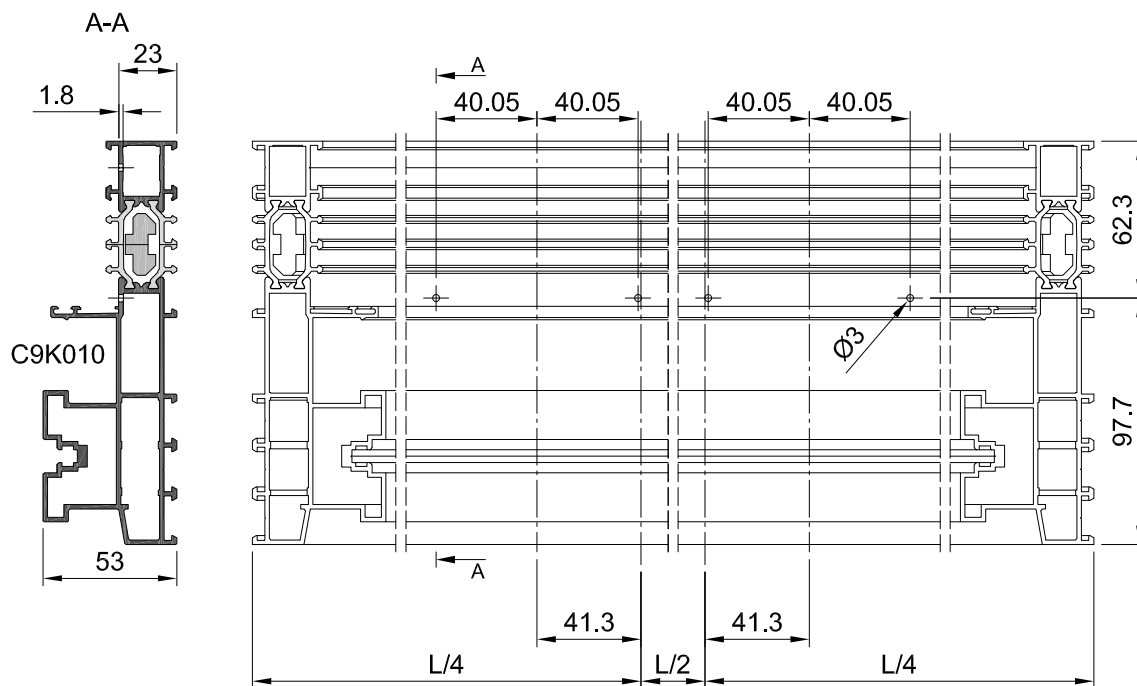
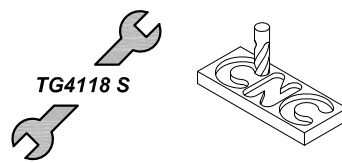
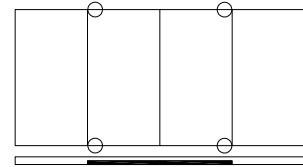



1-BINARIO (C9K010) TELAIO

TAPPO TENUTA CENTRALE CO1114 SUL PROFILATO SUPERIORE, ALZANTE-SCORREVOLE

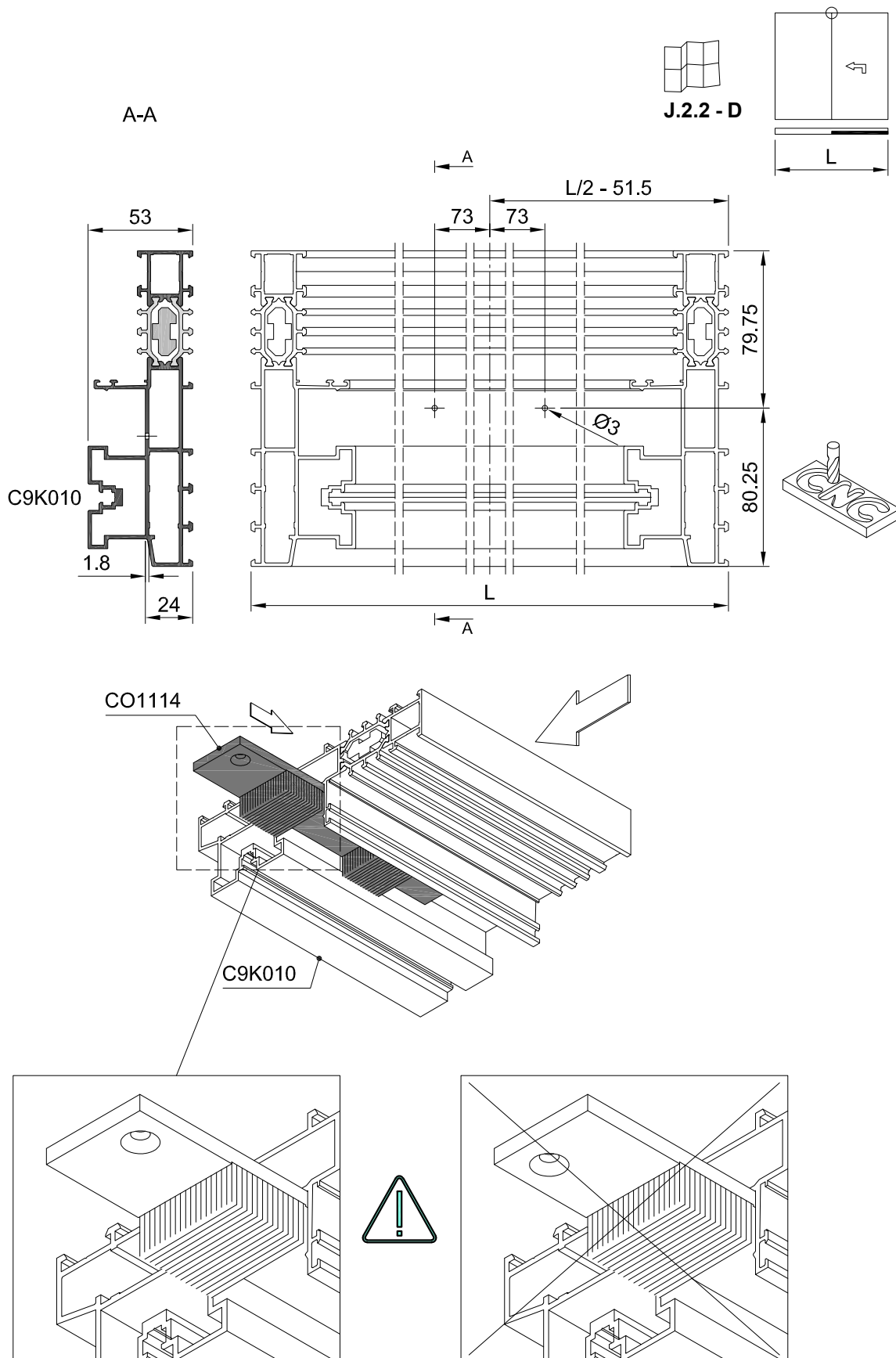

INSTALLAZIONE PUNTI DI CHIUSURA -ALZANTE-SCORREVOLE (ZB0034/ZB0035/ZB0036)

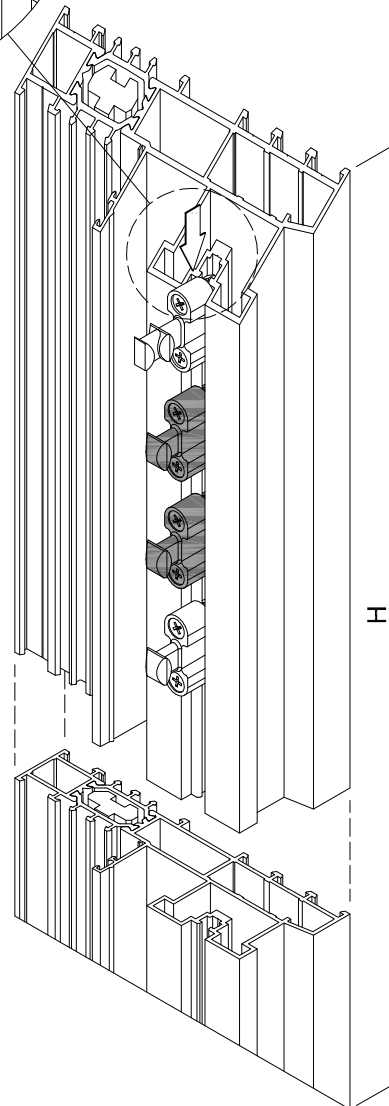
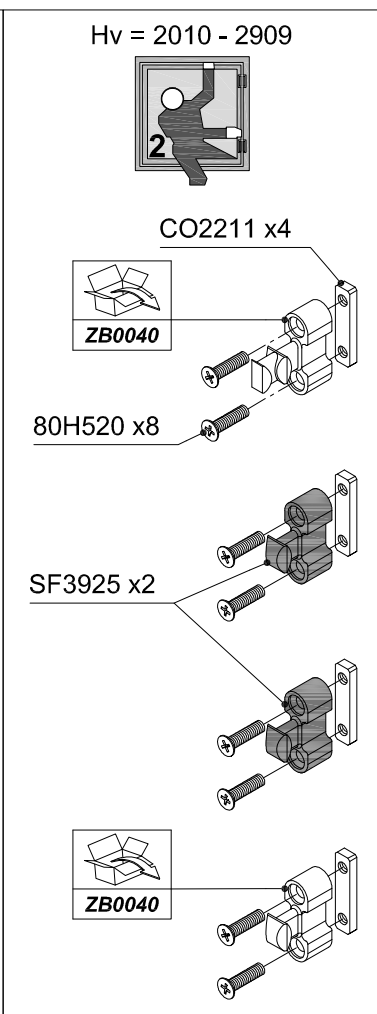
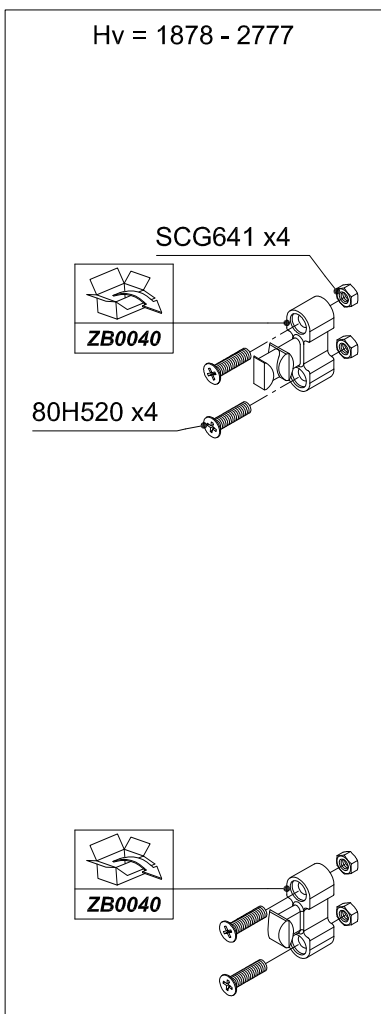
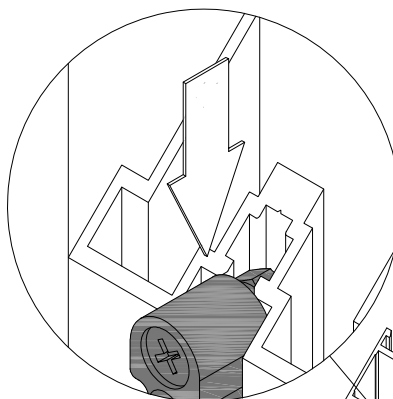
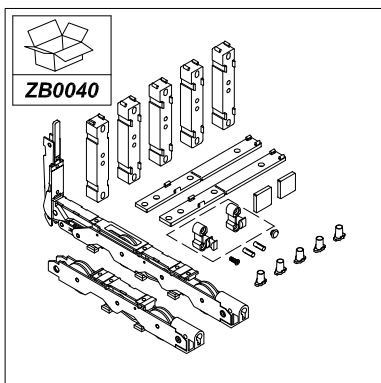
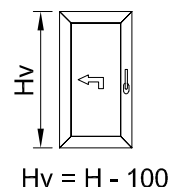
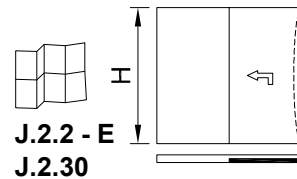



1-BINARIO (C9K010) TELAIO

INSTALLAZIONE CAVALLOTTI TS3M03 E TS3M04

3 / 6



J.2.2 - F
J.2.17

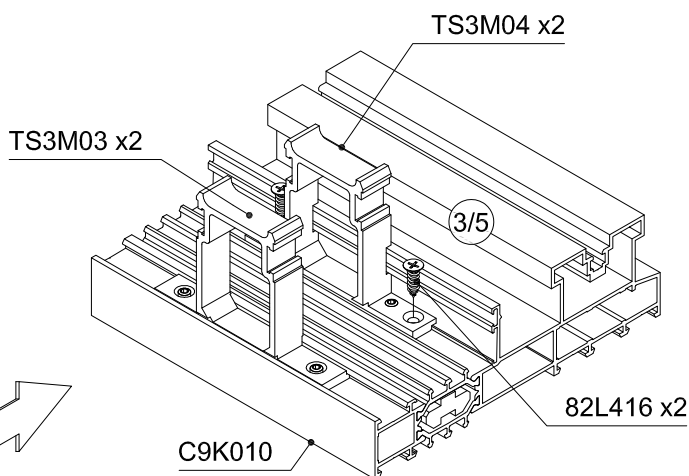
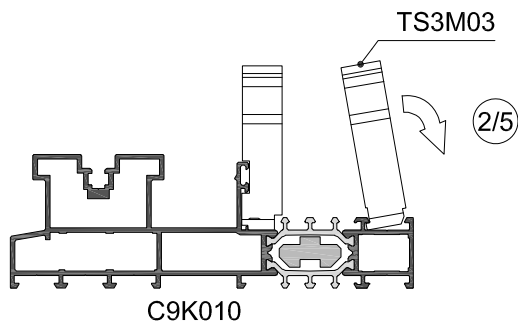
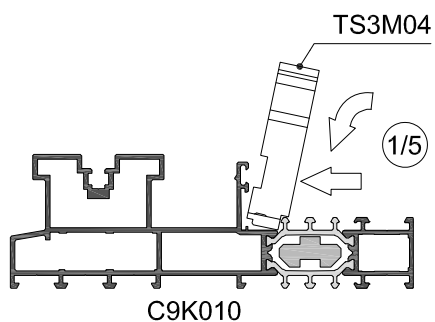
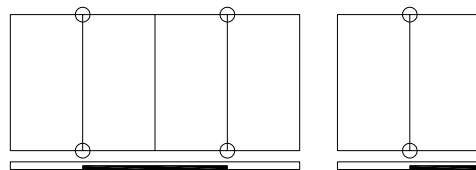

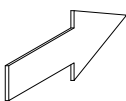
VISTA INTERNA

INSTALLAZIONE E SIGILLATURA MONTANTE INTERNO

4 / 6

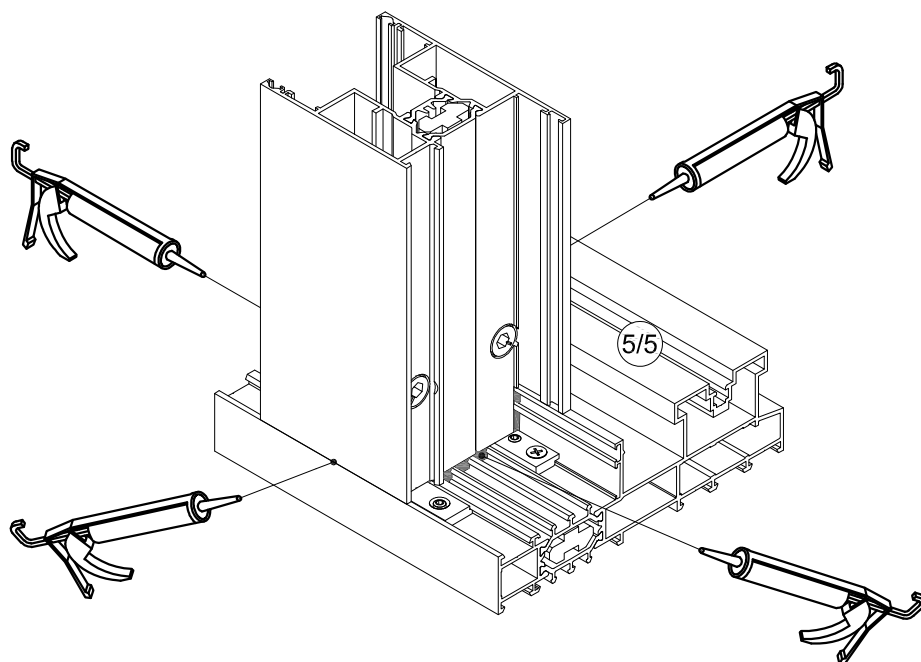
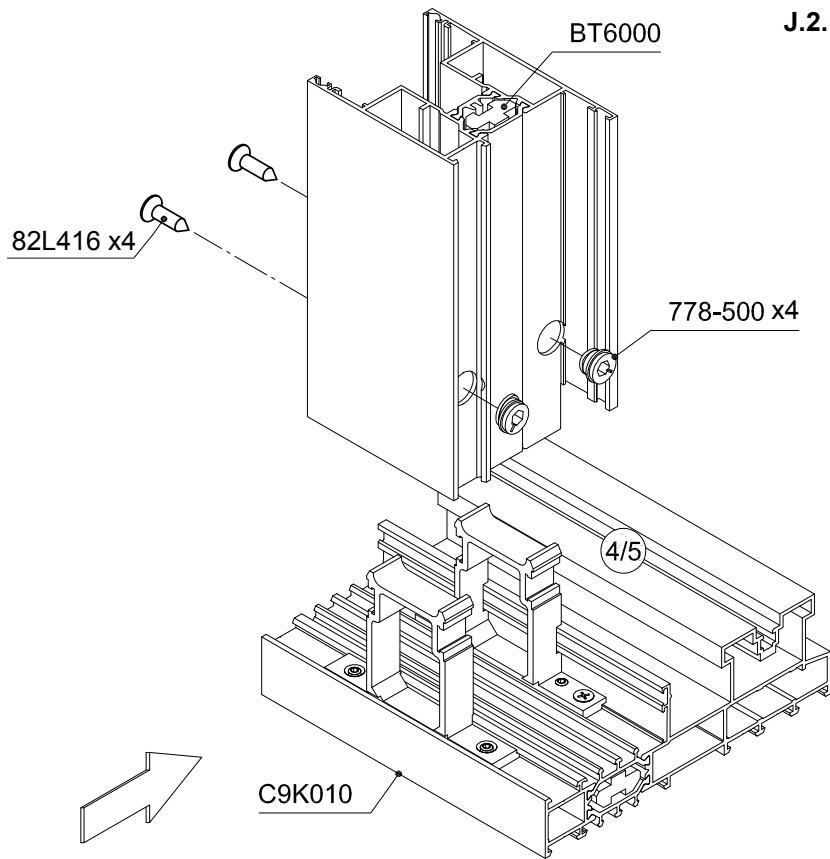
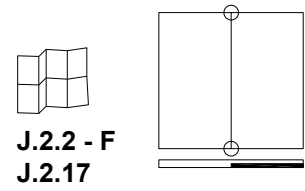



1-BINARIO (C9K010) TELAIO

INSTALLAZIONE E SIGILLATURA MONTANTE INTERNO - SCHEMA 4 ANTE

5 / 6



J.2.2 - F
J.2.17

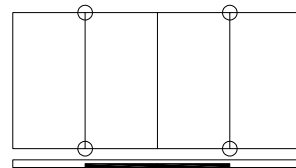

82L416 x8

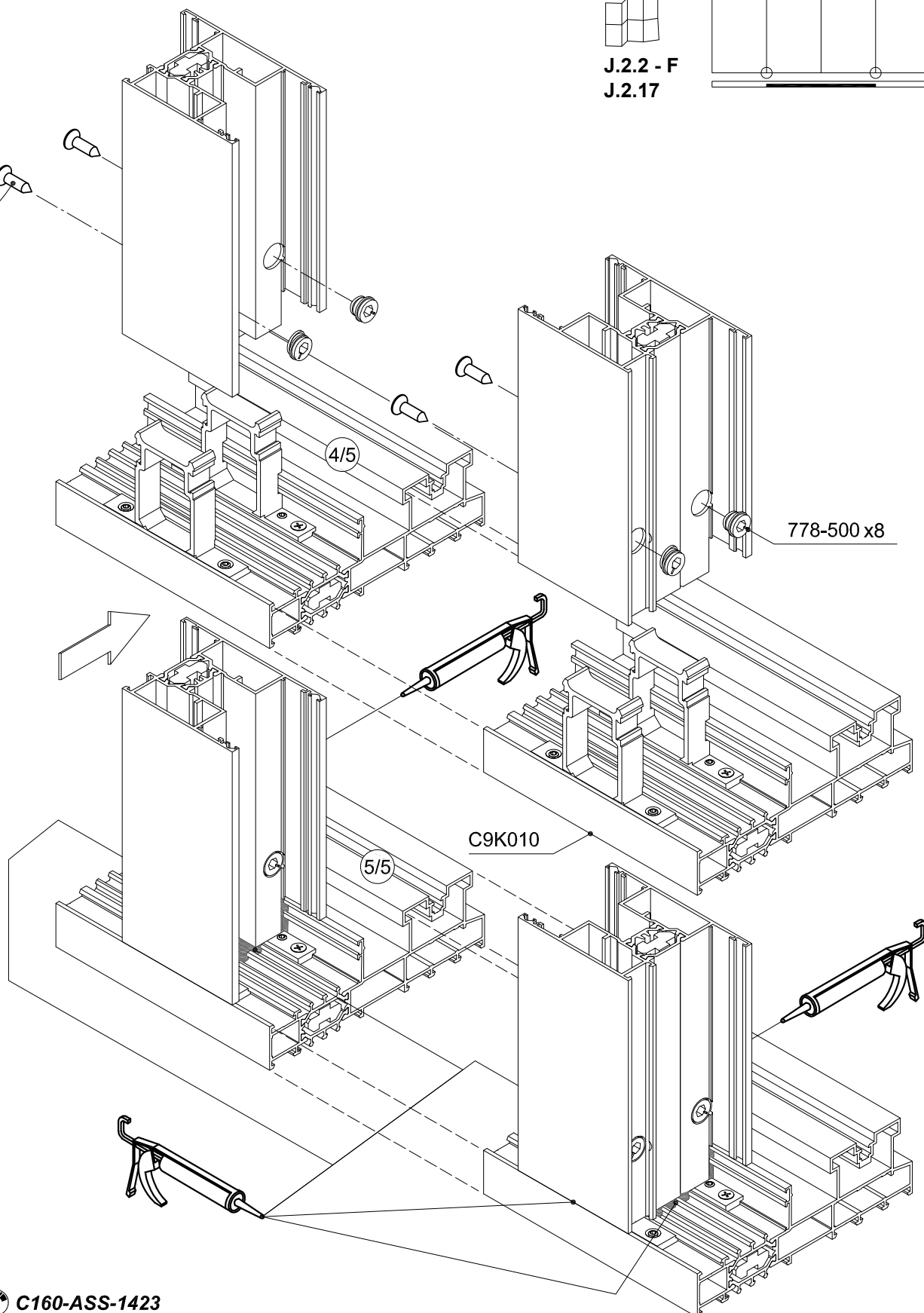

C160-ASS-1423

INSTALLAZIONE E SIGILLATURA MONTANTE INTERNO - TS9Z05

6 / 6

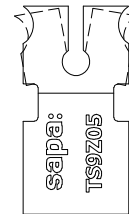
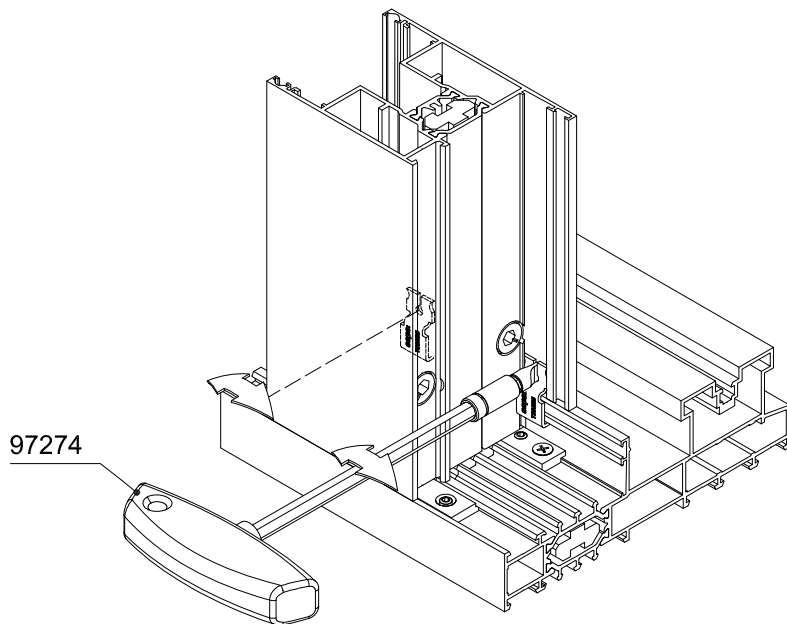
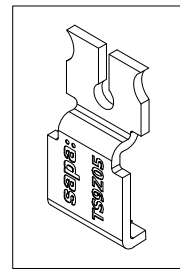
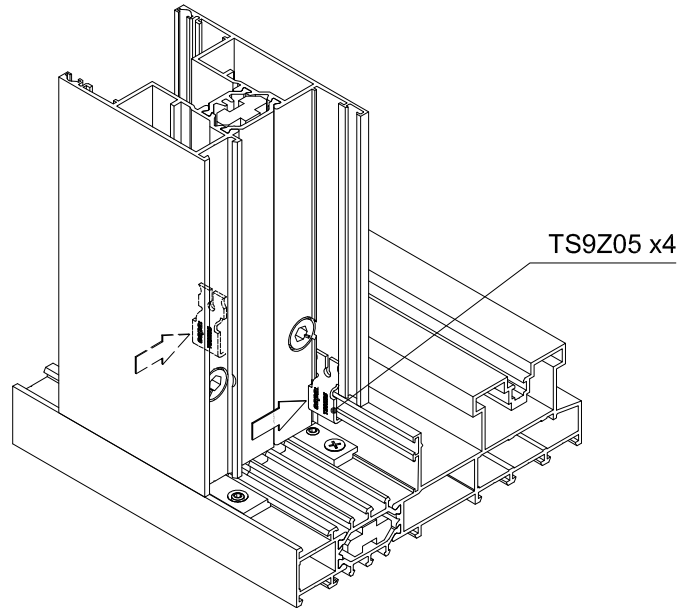
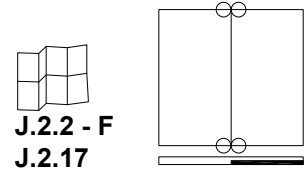



1-BINARIO (C9K010) TELAIO

ASSEMBLAGGIO PROFILATO TELAIO CON SQUADRETTE

1 / 3



J.2.2 - A
J.2.5

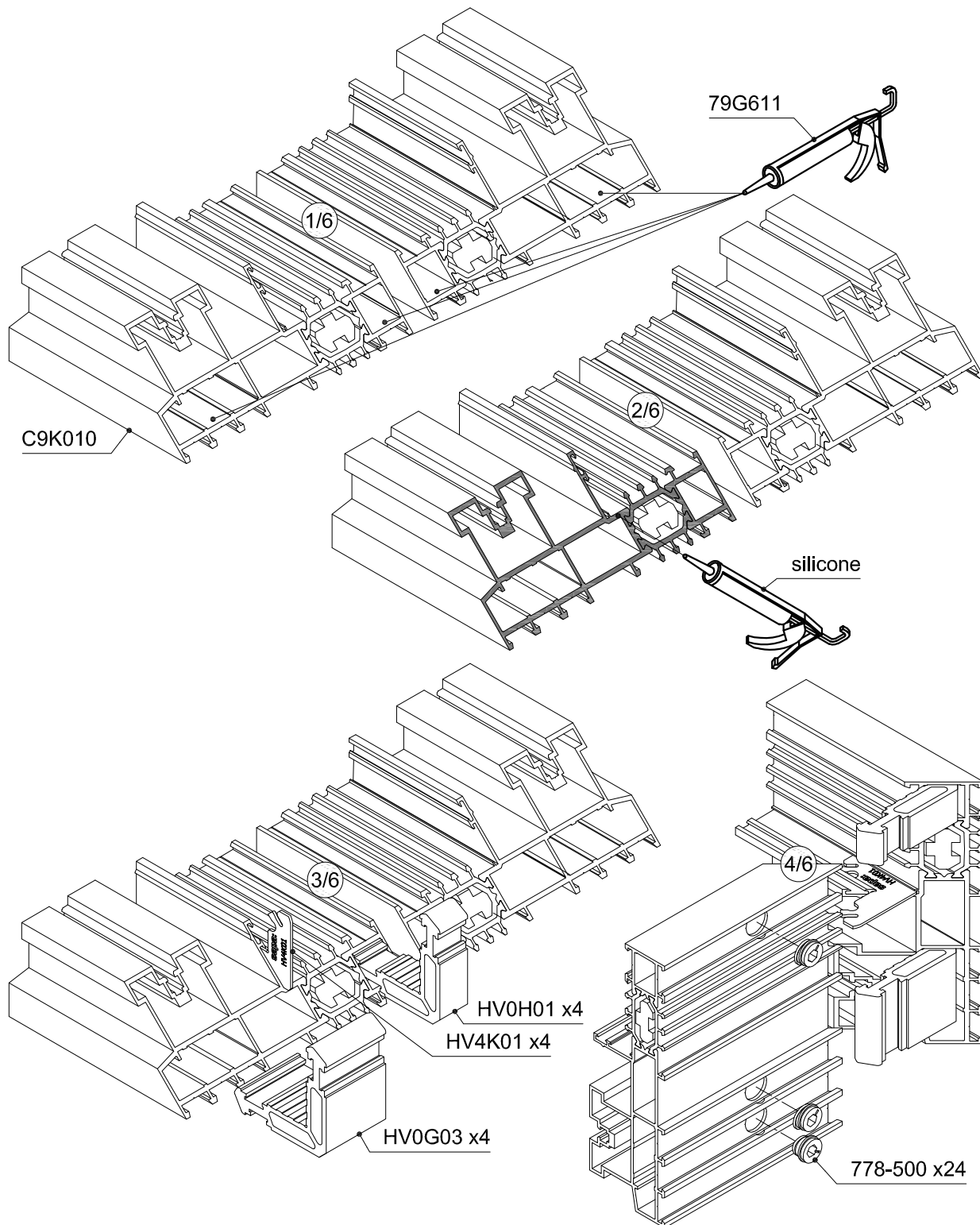
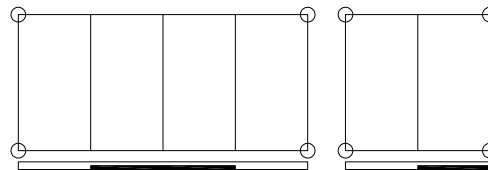

ASSEMBLAGGIO PROFILATO TELAIO CON SQUADRETTE

2 / 3



J.2.2 - A
J.2.5

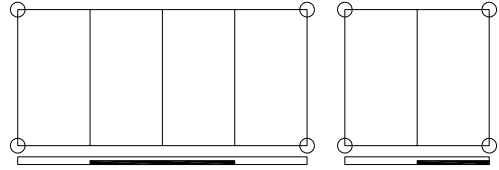

	BT6000
SHI	✓
SI	✓
I	x

BT6000*

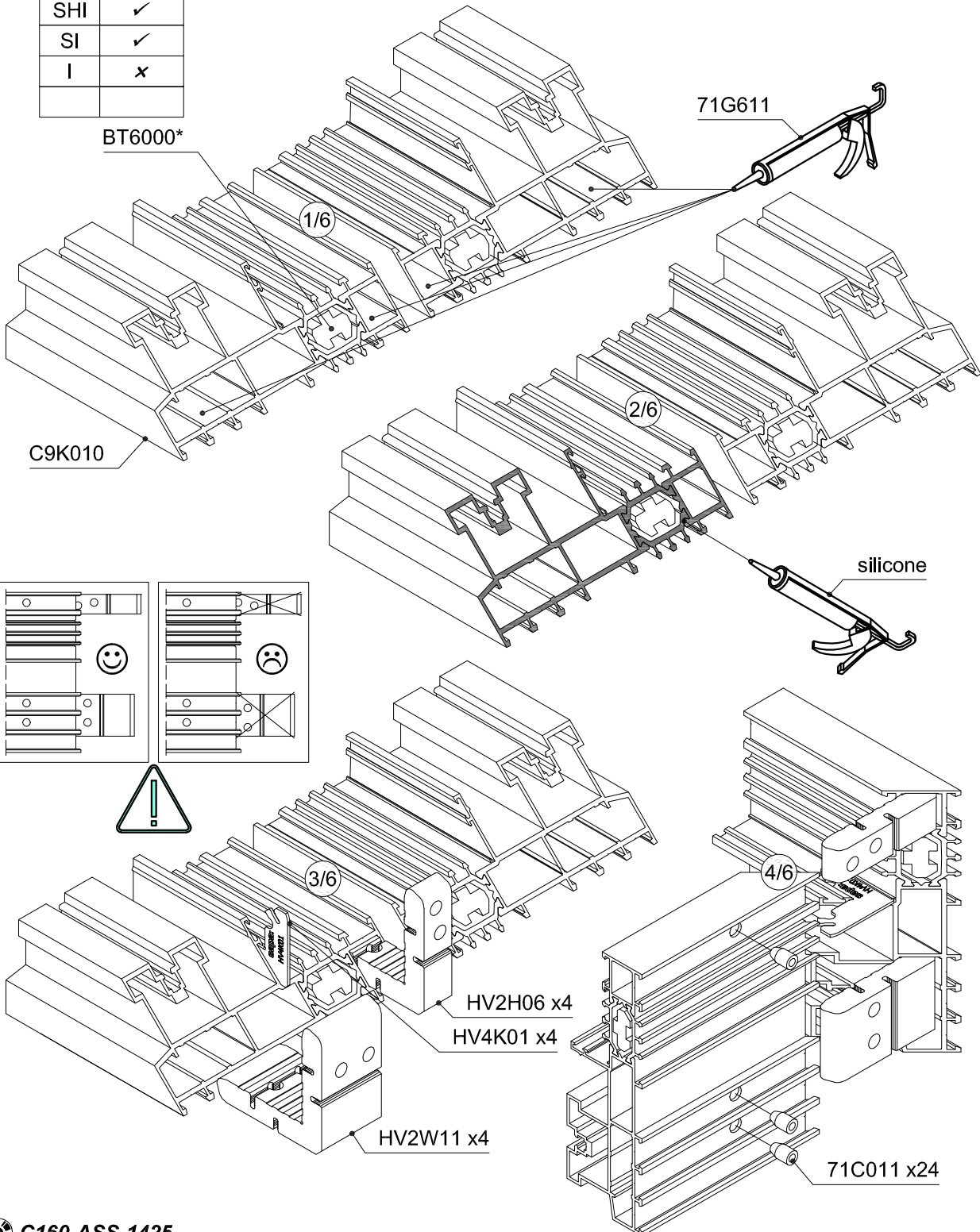



1-BINARIO (C9K010) TELAIO

ASSEMBLAGGIO PROFILATO TELAIO CON SQUADRETTE

3 / 3



J.2.2 - A

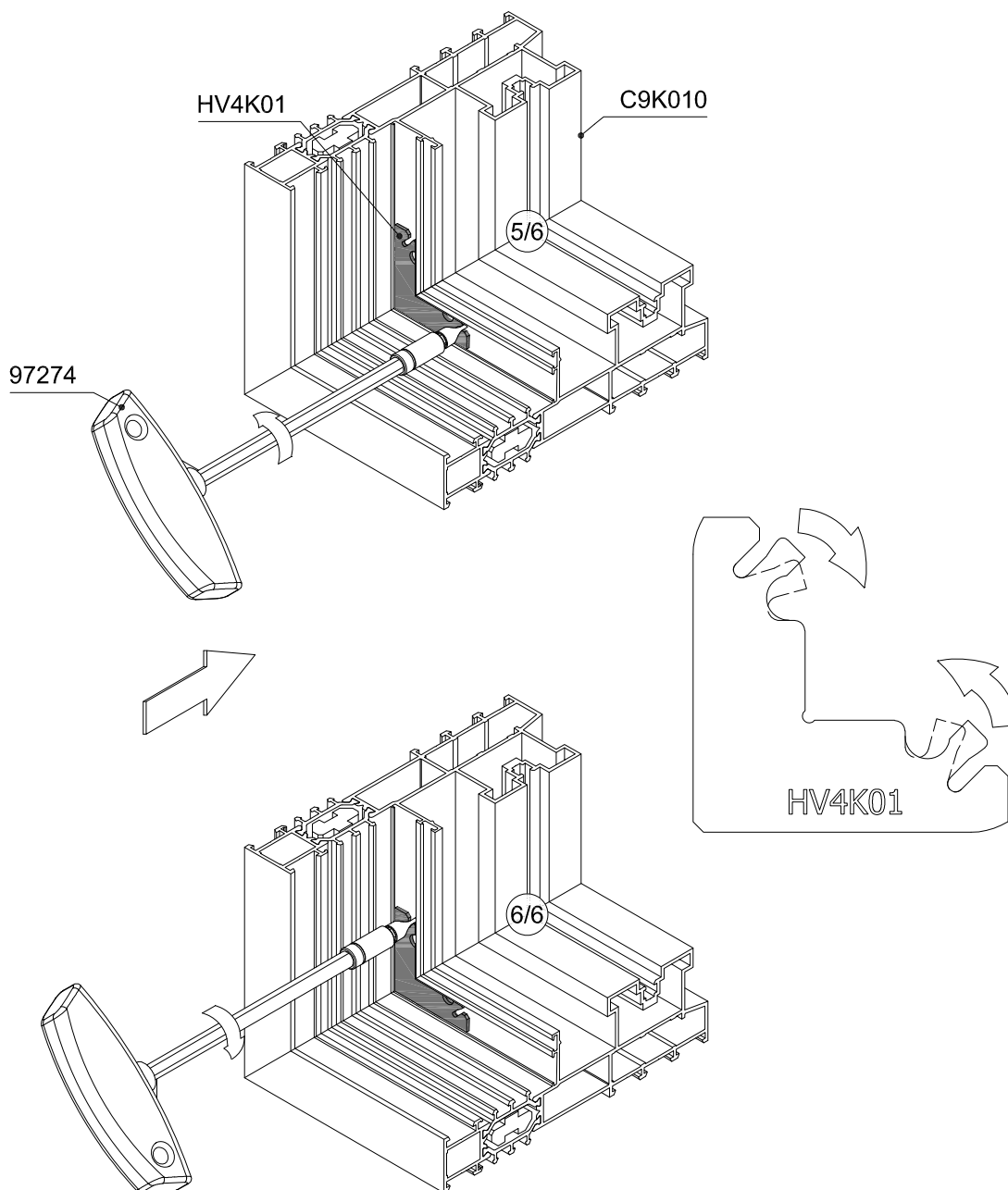
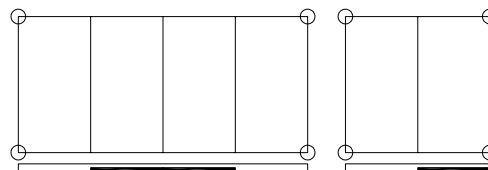

INSTALLAZIONE BINARIO CO1103

1 / 2

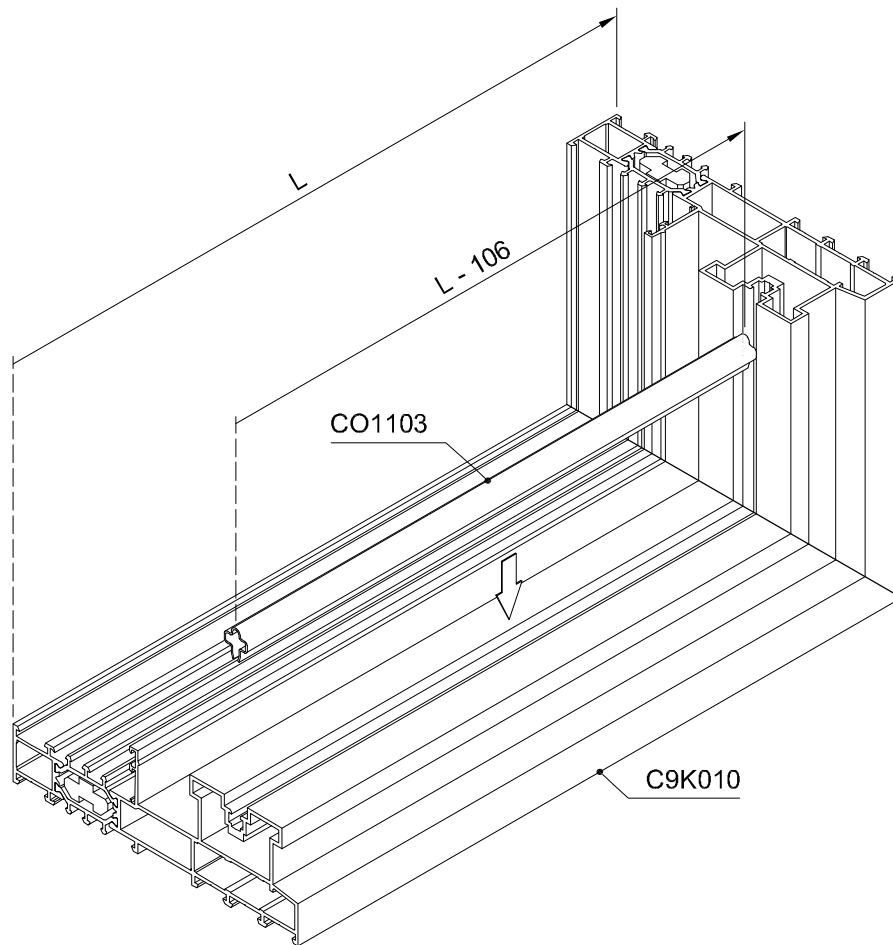
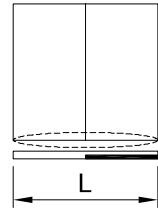



1-BINARIO (C9K010) TELAIO

INSTALLAZIONE BINARIO CO1103 E ZB0038 PER SCHEMA 4 ANTE



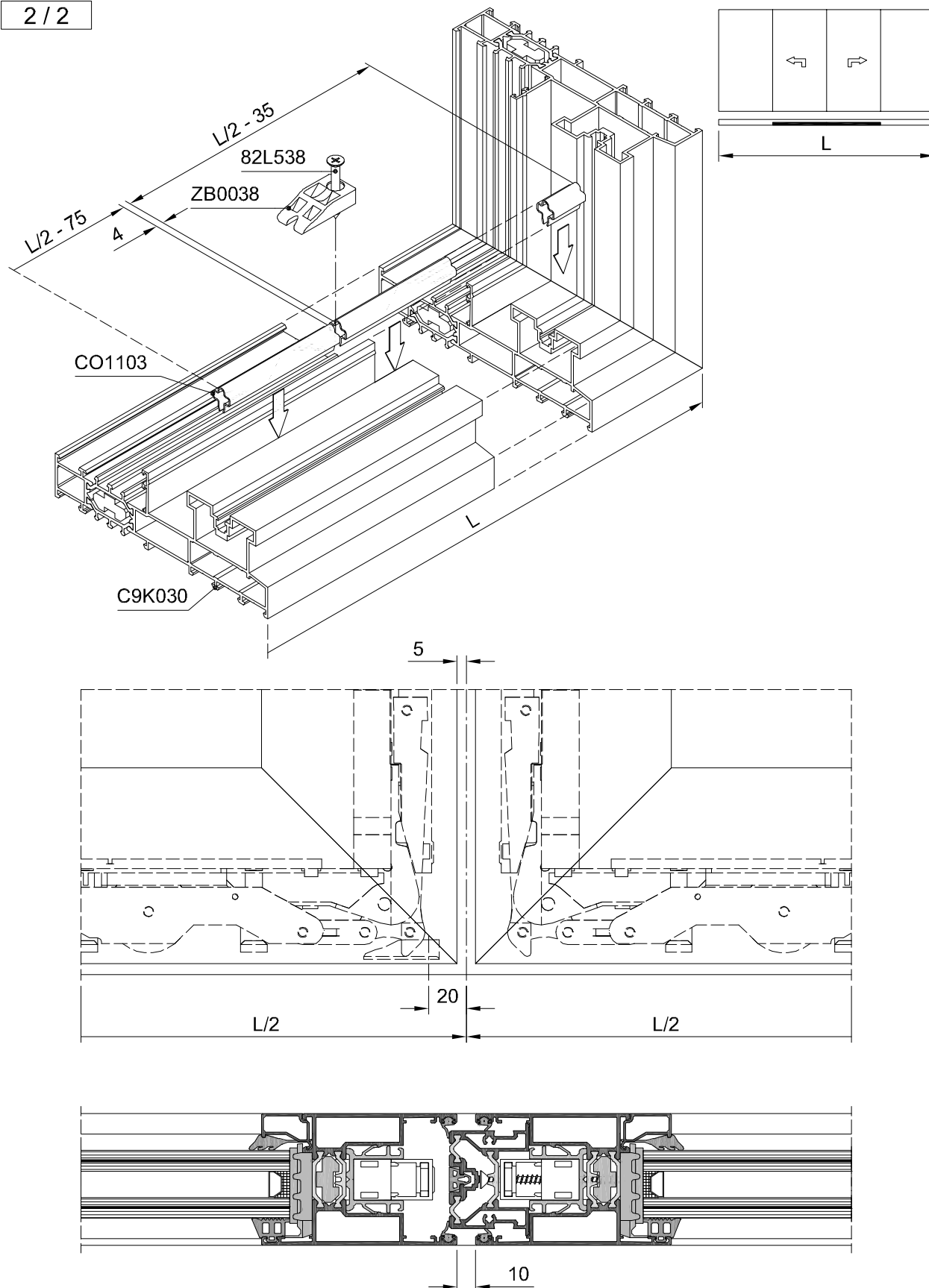

2 / 2

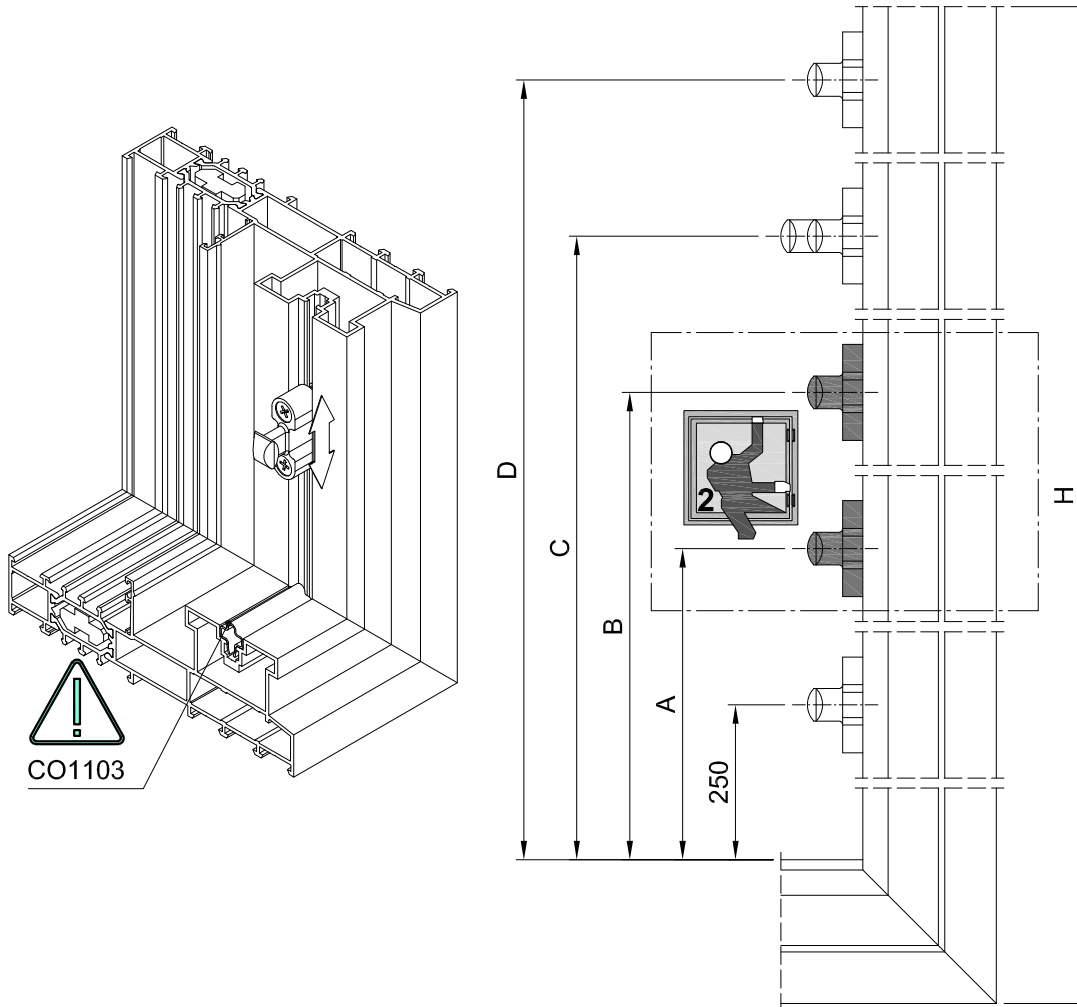
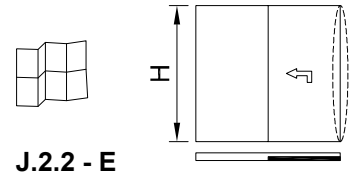

INSTALLAZIONE PUNTI DI CHIUSURA -ALZANTE-SCORREVOLE

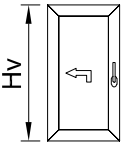
1 / 2



	Hv							 Hv = H - 88
				A	B	C	D	
	1180 - 1877	1312 - 2009	ZB0033	-	600	1000	-	
	1878 - 2177	2010 - 2309	ZB0034	750	1200	1600		
	2178 - 2477	2310 - 2609	ZB0035			1900		
	2478 - 2777	2610 - 2909	ZB0036			2200		
	2778 - 3077	2910 - 3209	ZB0035 + ZB0046			750	1200	1900
	3078 - 3377	3210 - 3509	ZB0036 + ZB0046	2200				



1-BINARIO (C9K010) TELAIO

INSTALLAZIONE GUARNIZIONE DI FINITURA RU9704

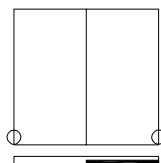
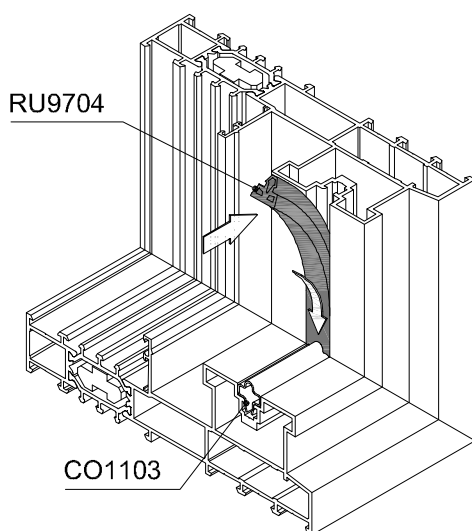
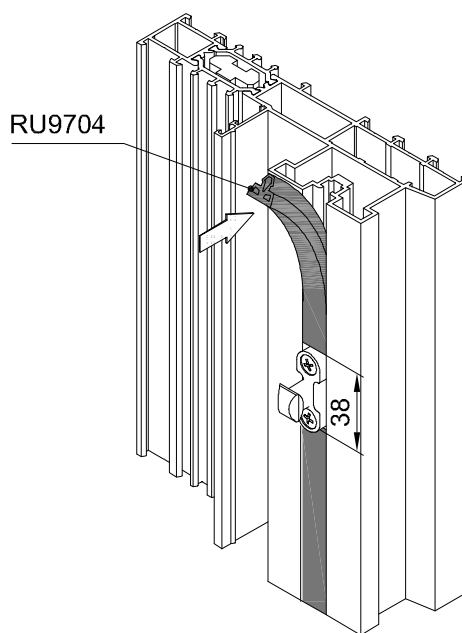
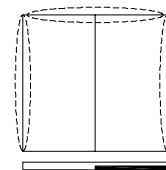

PREPARAZIONE LABIRINTO KU2029 + RU9095 + KU6004 + RU9703 + CO2181 + VS9148

1 / 5

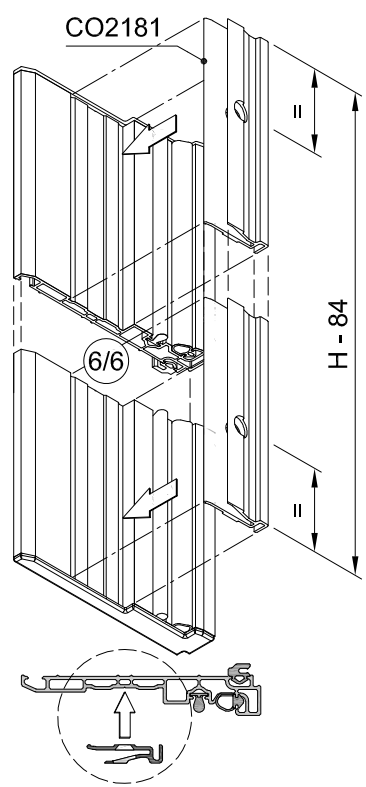
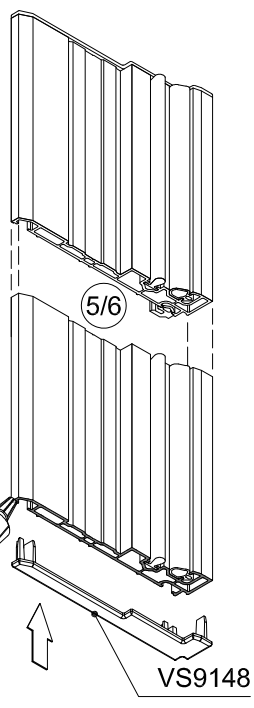
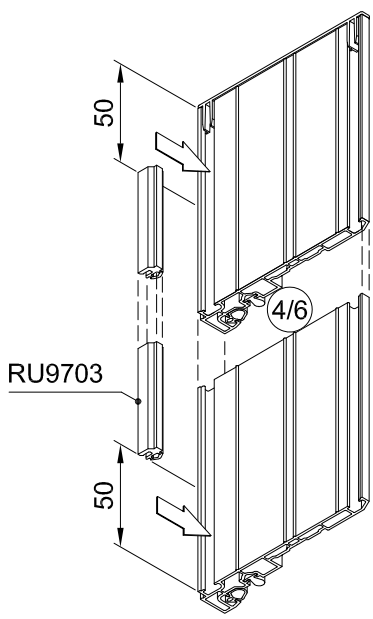
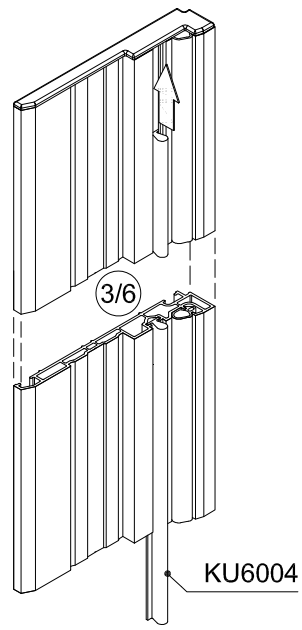
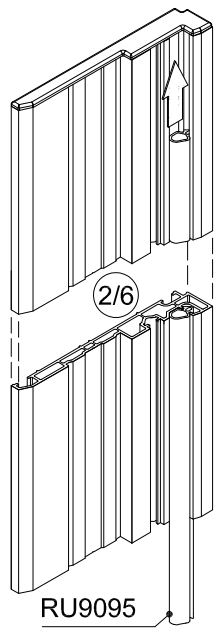
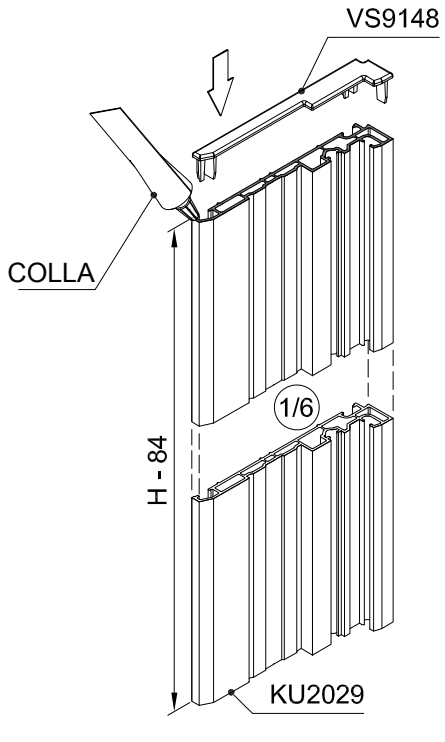
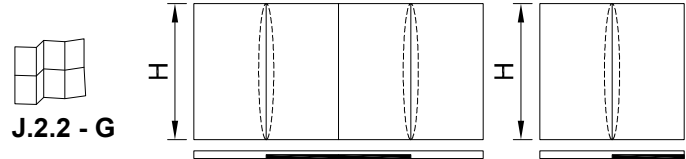



1-BINARIO (C9K010) TELAIO

LAVORAZIONE ADDIZIONALE LABIRINTO SU MONTANTE INTERNO

2 / 5



J.2.2 - G

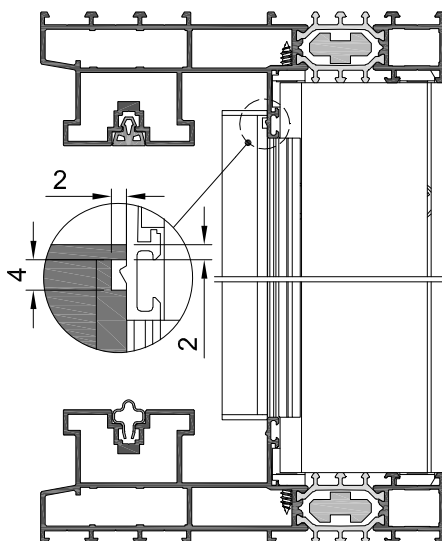
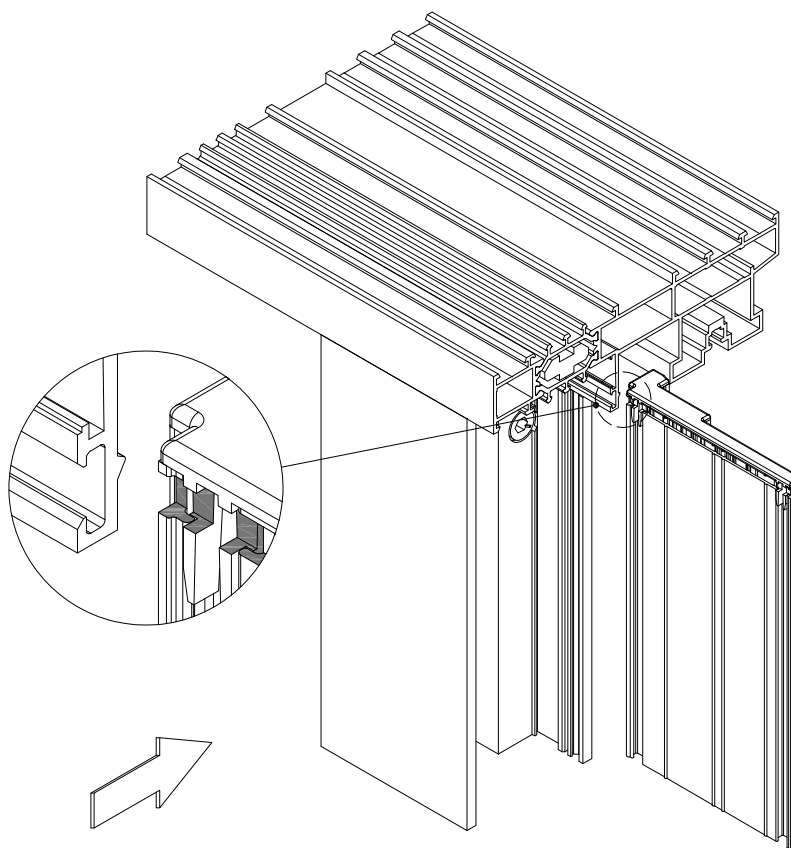
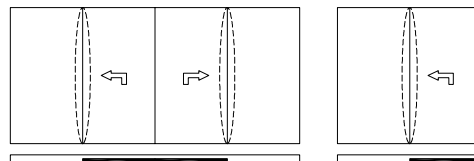

INSTALLAZIONE LABIRINTO SU MONTANTE INTERNO

3 / 5



J.2.2 - G

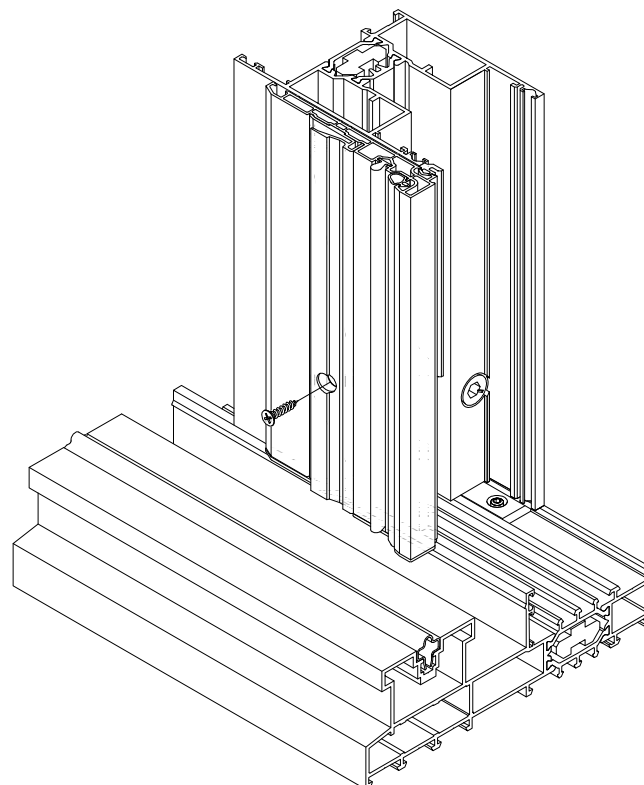
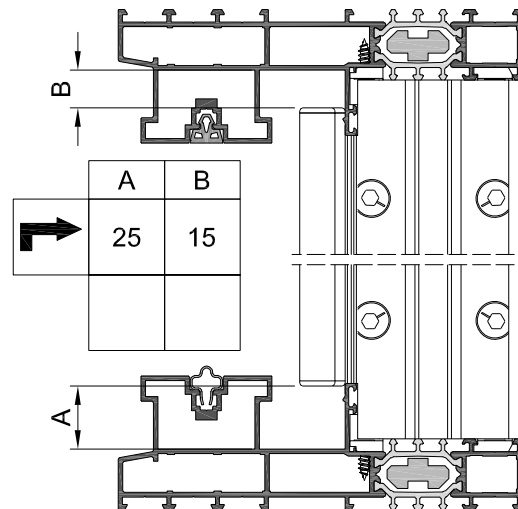
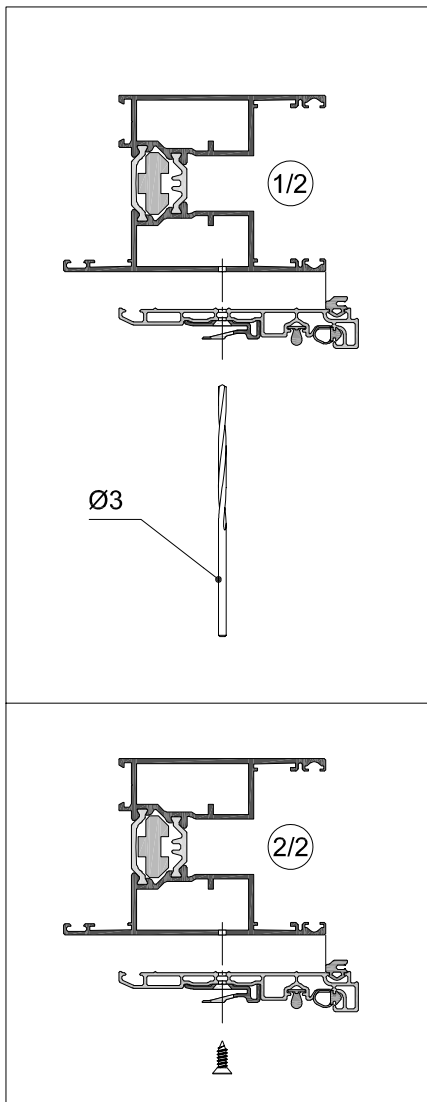
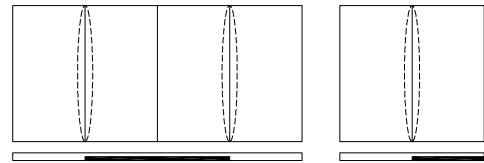



1-BINARIO (C9K010) TELAIO

INSTALLAZIONE RU9094 E BT6013

4 / 5



J.2.2 - G

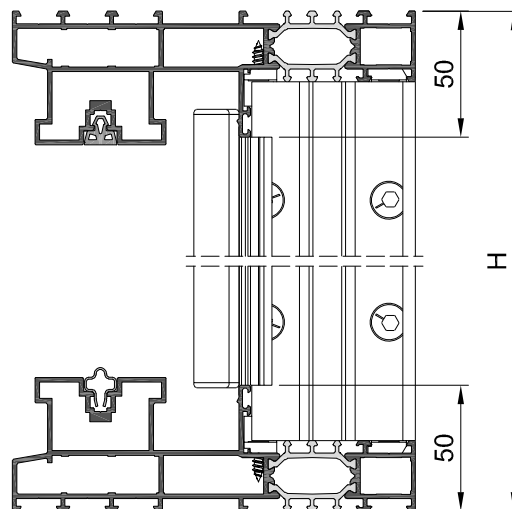
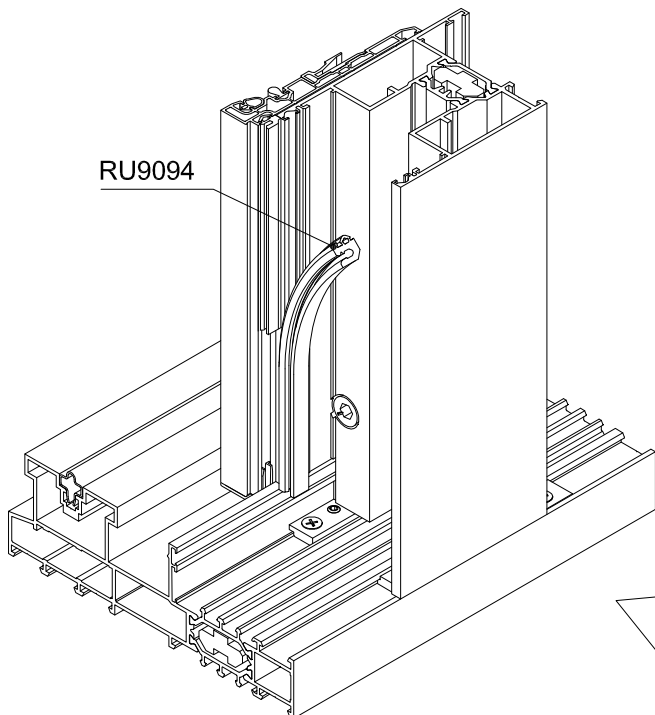
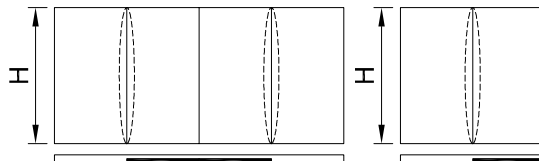

	BT6013
SHI	✓
SI	✓
I	x

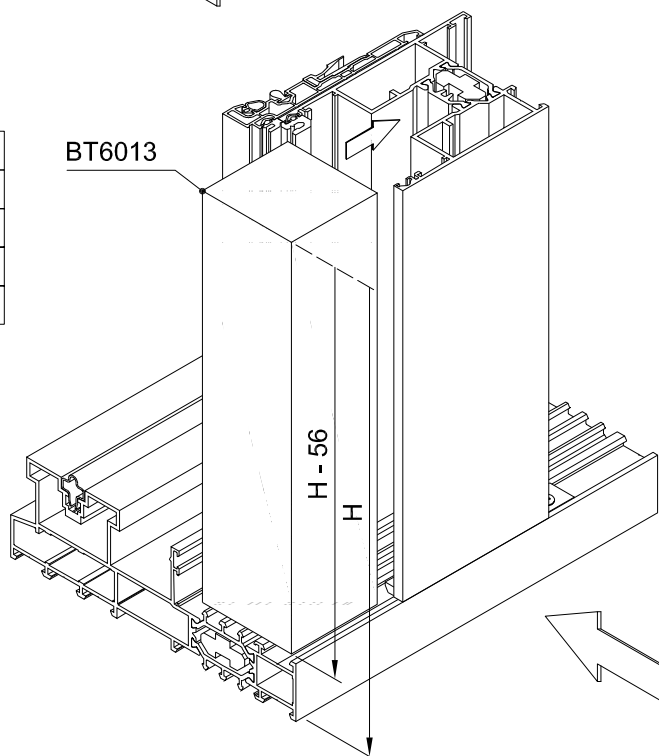
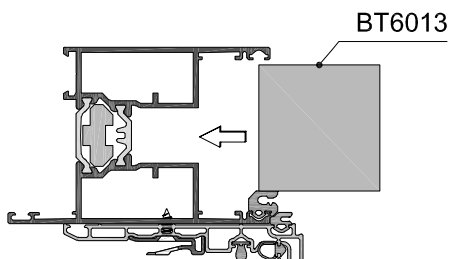

PREPARAZIONE E INSTALLAZIONE CARTELLINA C9A002

5 / 5

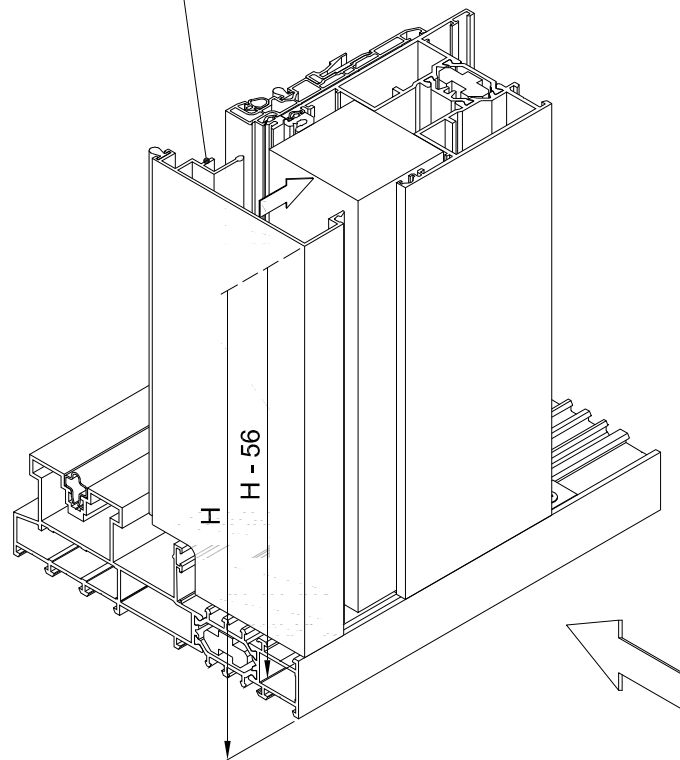
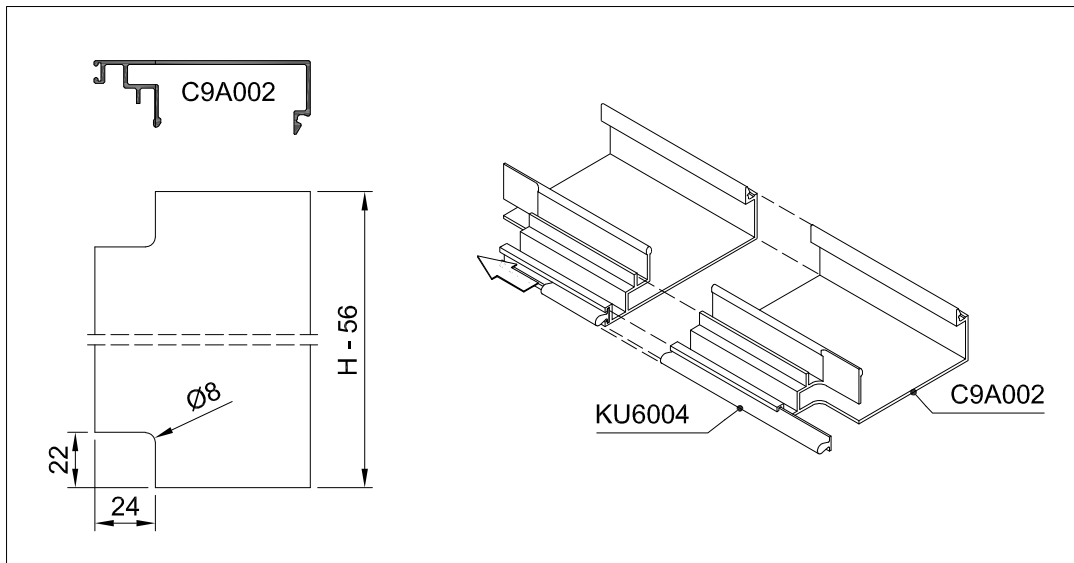
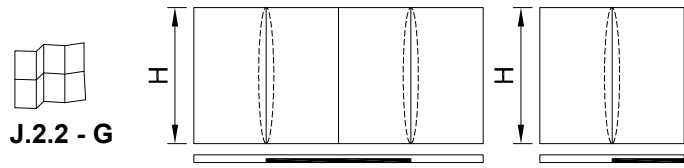



1-BINARIO TELAIIO SOGLIA RIBASSATA TAGLIO 90°

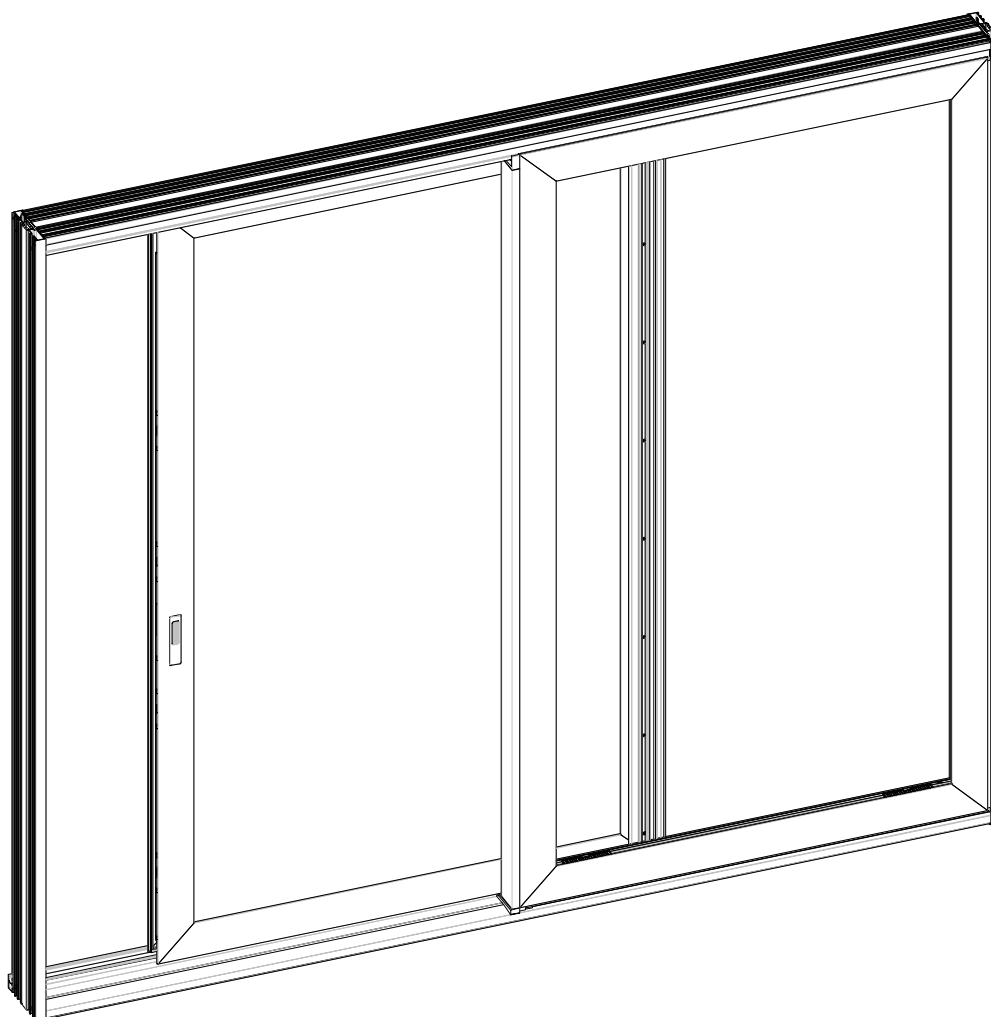

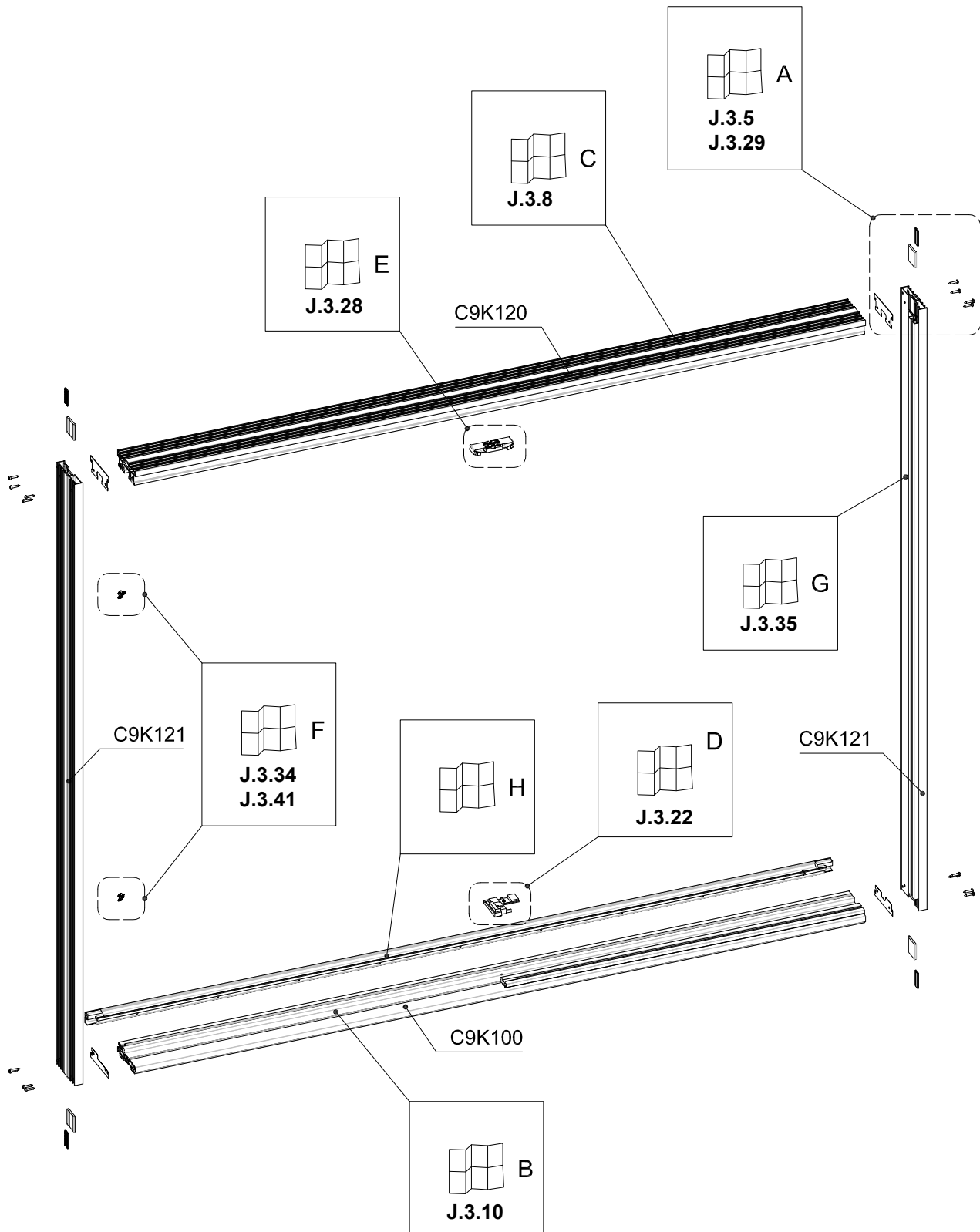



1-BINARIO TELAIO SOGLIA RIBASSATA TAGLIO 90°

CONTENUTO

1-binario telaio soglia ribassata taglio 90°	J.4.1
Contenuto	J.4.3



Taglio C9K121	J.4.4
Taglio C9K121 per connessione telai	J.4.5
Taglio del C9K120 + KU2028 e installazione BT6006	J.4.8
Taglio del C9K100 + KU2035 e installazione BT6017	J.4.9



Panoramica drenaggi	J.4.10
C9K100 lavorazione drenaggio - H	J.4.11
C9K100 lavorazione drenaggio - B2	J.4.12
C9K100 lavorazione drenaggio - A	J.4.13
C9K100 lavorazione drenaggio - A1	J.4.14
C9K100 lavorazione drenaggio - A2	J.4.15
C9K100 lavorazione drenaggio - G	J.4.16
KU2035 lavorazione drenaggio - B	J.4.17



Installazione VS0107	J.4.18
Sigillatura KU2035	J.4.19
Sigillatura centrale del C9K100 per assemblaggio con KU2035	J.4.20
Installazione KU2035 su C9K100	J.4.21
Installazione sigillatura centrale inferiore	J.4.22
C9A101 lavorazione drenaggio - K2	J.4.23
Installazione C9A101	J.4.24
Installazione e sigillatura	J.4.25
Installazione RU9131 + RU9704 + VS0107 + CO1137	J.4.26
Anta fissa soglia ribassata - lavorazione profilato cartellina speciale	J.4.27
Installazione CO1111 tappo sigillatura centrale superiore	J.4.28
Installazione connessioni inferiori CO0132 e VS9957 su C9K121	J.4.29
Installazione connessioni superiori CO0132 e VS9957 su C9K121	J.4.30
Installazione VS9956 e VS9970 su anta fissa laterale	J.4.31
Installazione VS9956 e VS9970 su anta mobile laterale	J.4.32



Montaggio su telaio	J.4.33
Blocchetti chiusura alzante-scorrevole su C9A100 (ZB0034/ZB0035/ZB0036)	J.4.34
Sigillatura angoli con RU9704	J.4.35
Installazione C9A100 e 213-006 su anta mobile laterale	J.4.36
Installazione C9A100 e 213-006 su anta fissa laterale	J.4.37
Installazione KU2035 sui lati	J.4.38
Installazione binario CO1103	J.4.39
Installazione binario CO1103 e ZB0038 per schema 4 ante	J.4.40
Posizionamento punti di chiusura	J.4.41
Lavorazione drenaggio C9K102	J.4.42
Montaggio drenaggio C9A102	J.4.43
Montaggio drenaggio C9A102	J.4.44
Montaggio drenaggio C90102	J.4.45

TAGLIO C9K121

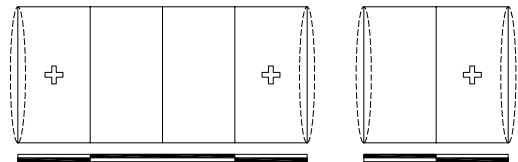
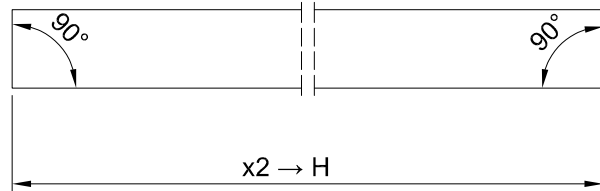
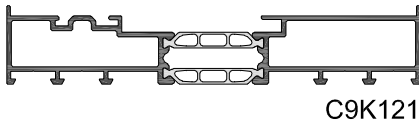
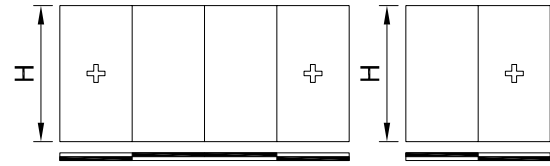

BT6019	
SHI	✓
SI	✓
I	x

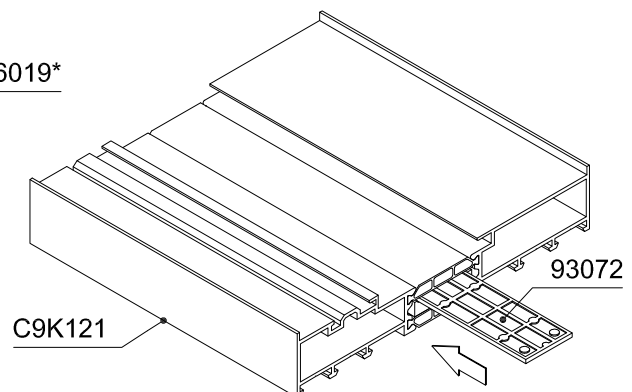
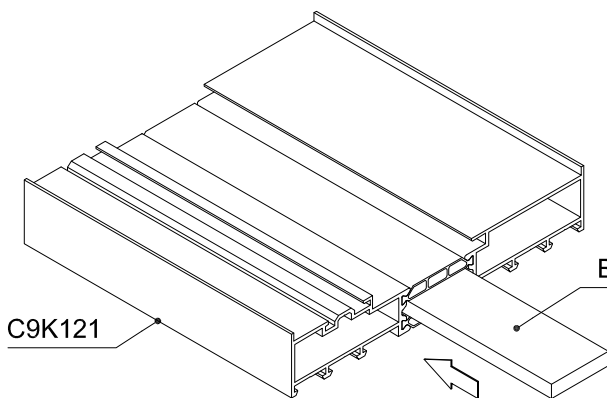



1-BINARIO TELAIO SOGLIA RIBASSATA TAGLIO 90°

TAGLIO C9K121 PER CONNESSIONE TELAI

1 / 3

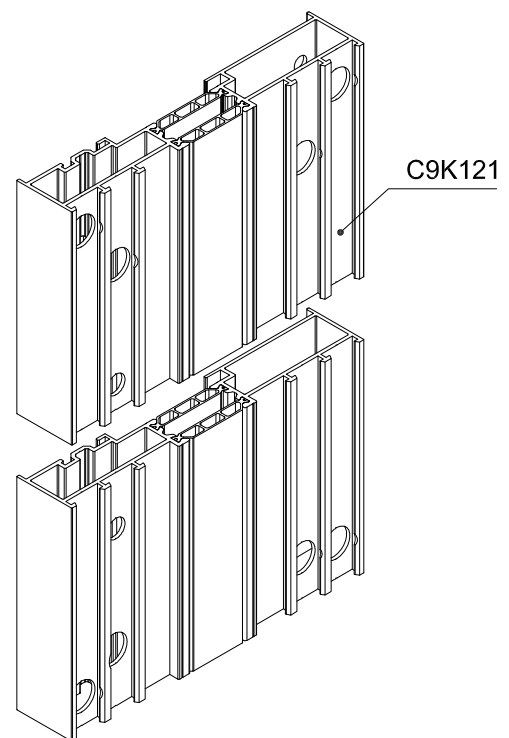
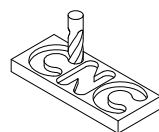
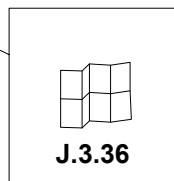
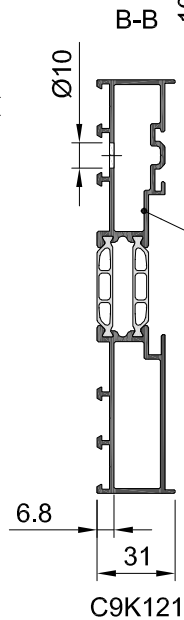
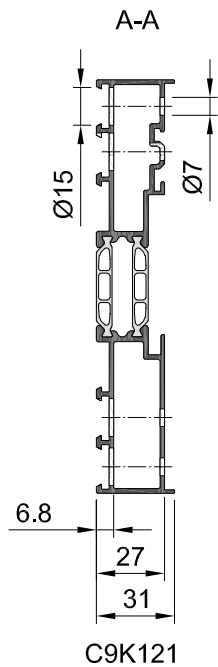
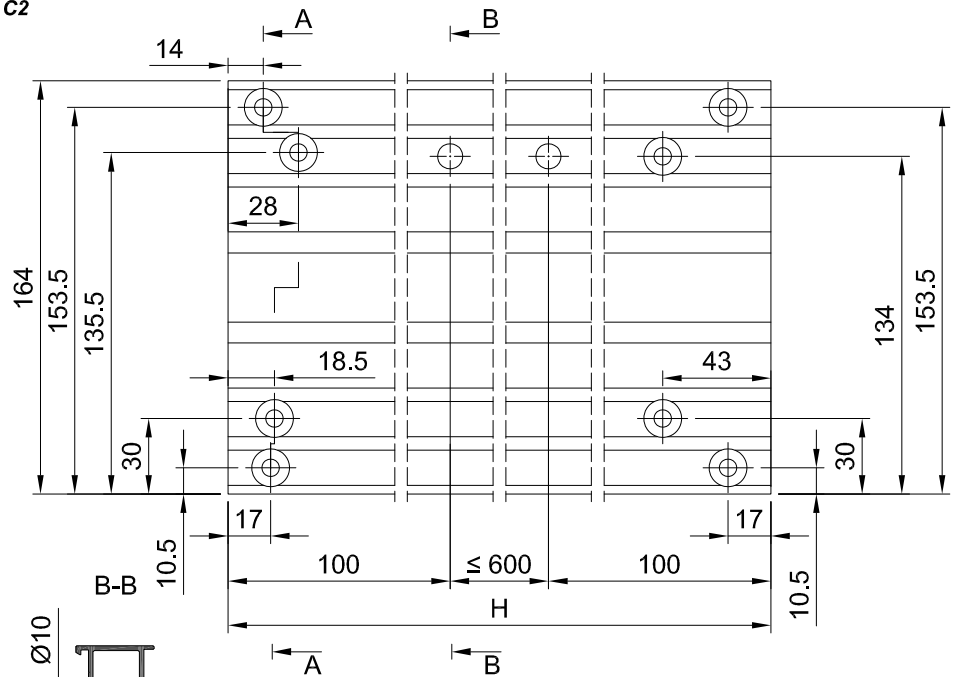
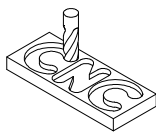
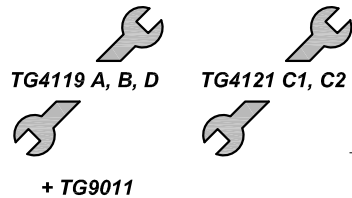
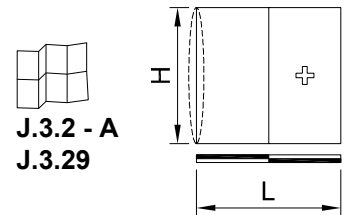

TAGLIO C9K121 PER CONNESSIONE TELAI

2 / 3

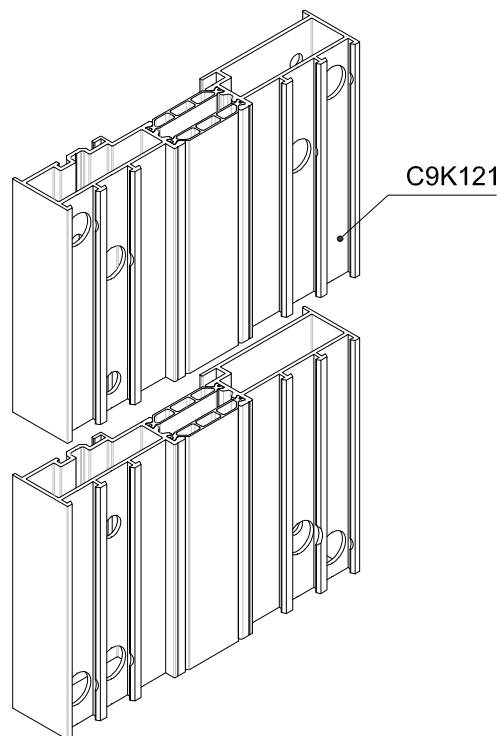
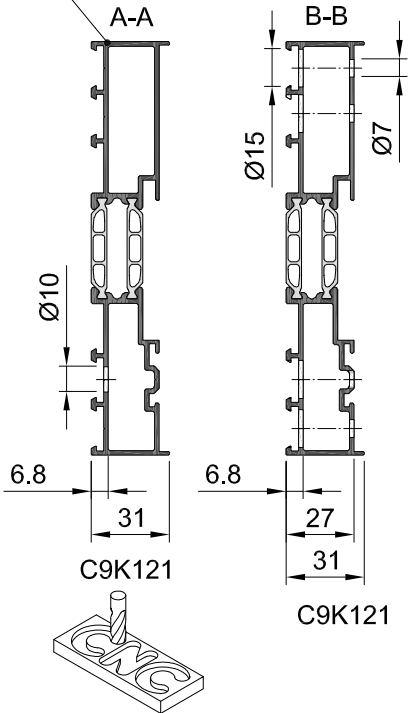
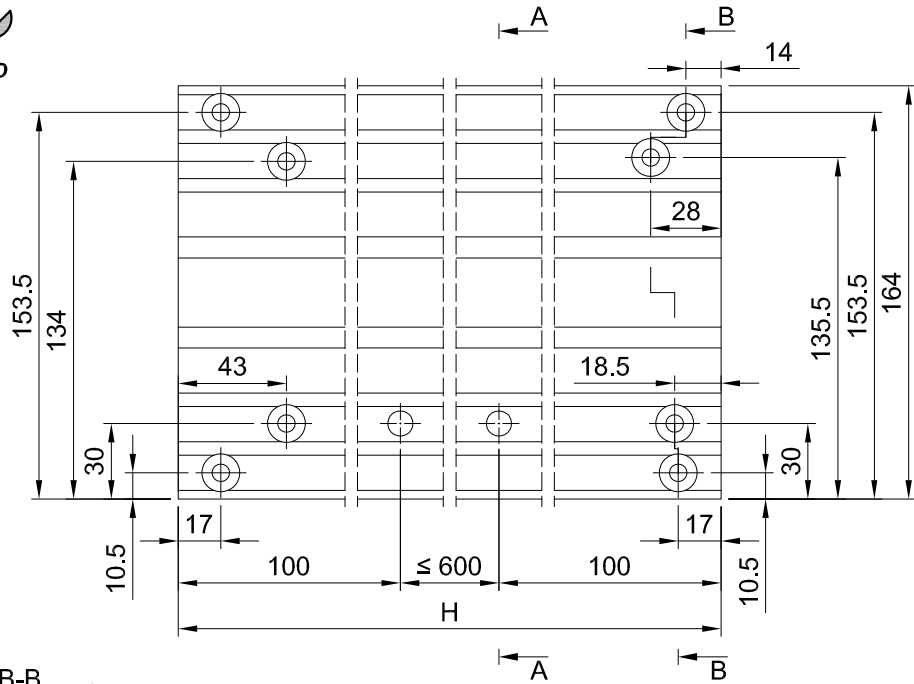
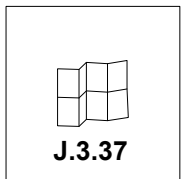
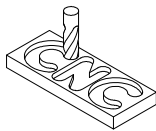
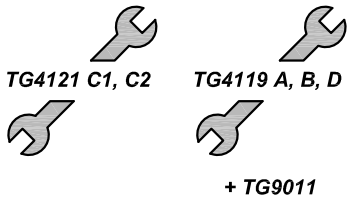
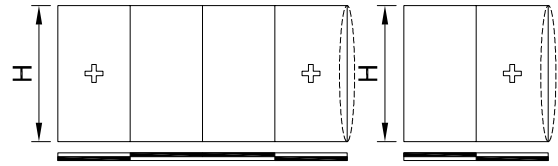
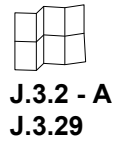



1-BINARIO TELAIO SOGLIA RIBASSATA TAGLIO 90°

TAGLIO C9K121 PER CONNESSIONE TELAI

3 / 3

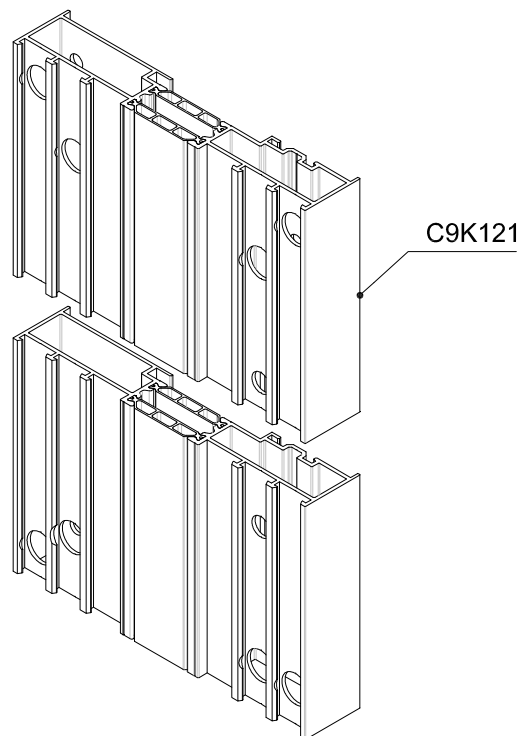
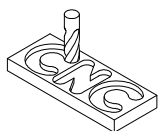
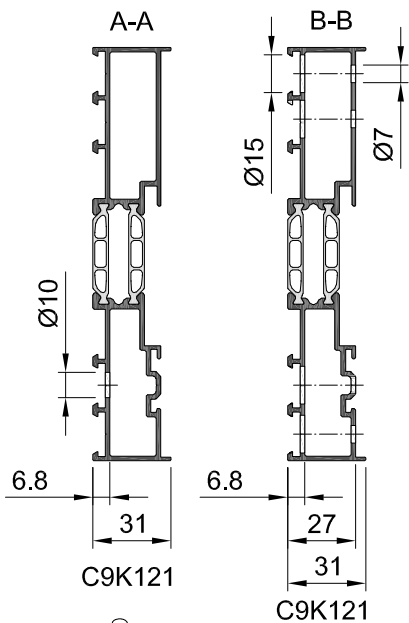
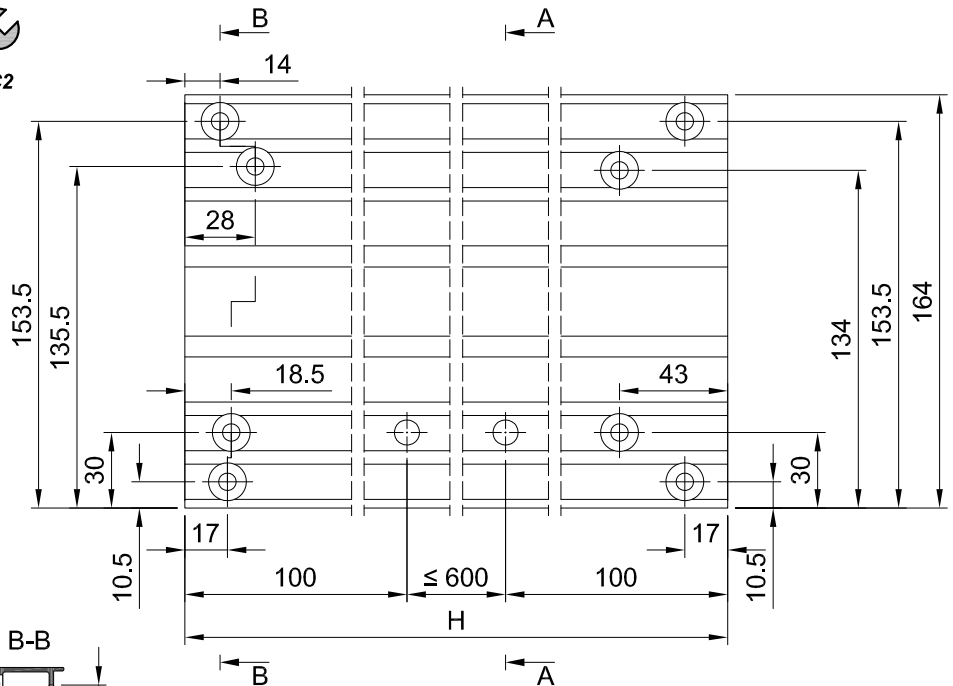
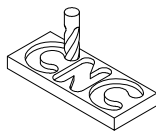
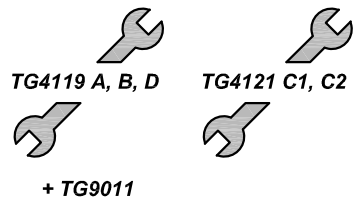
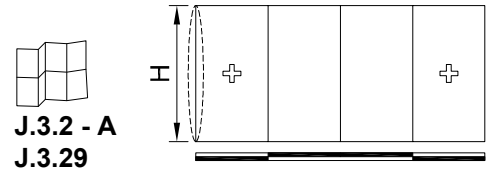

TAGLIO DEL C9K120 + KU2028 E INSTALLAZIONE BT6006

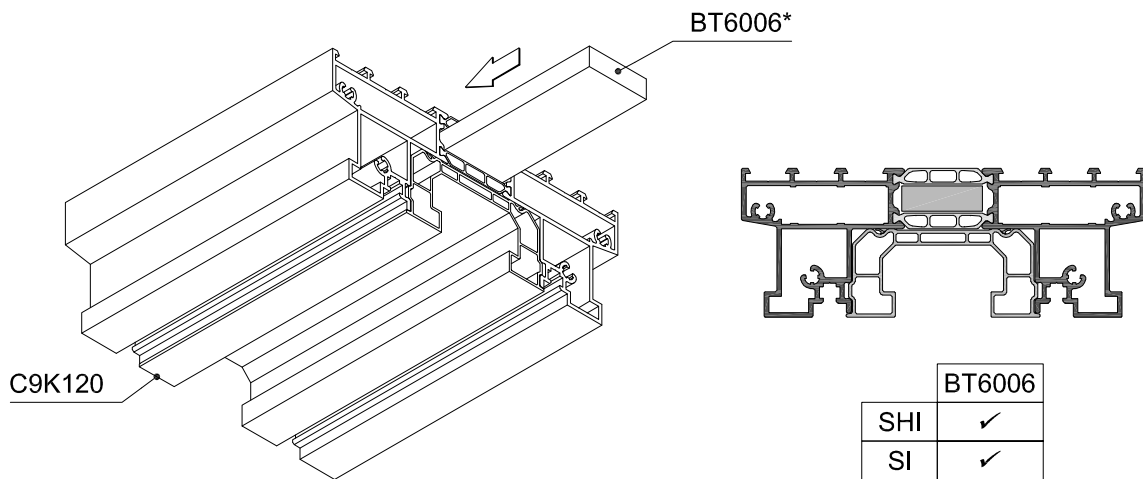
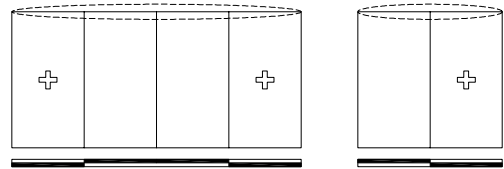
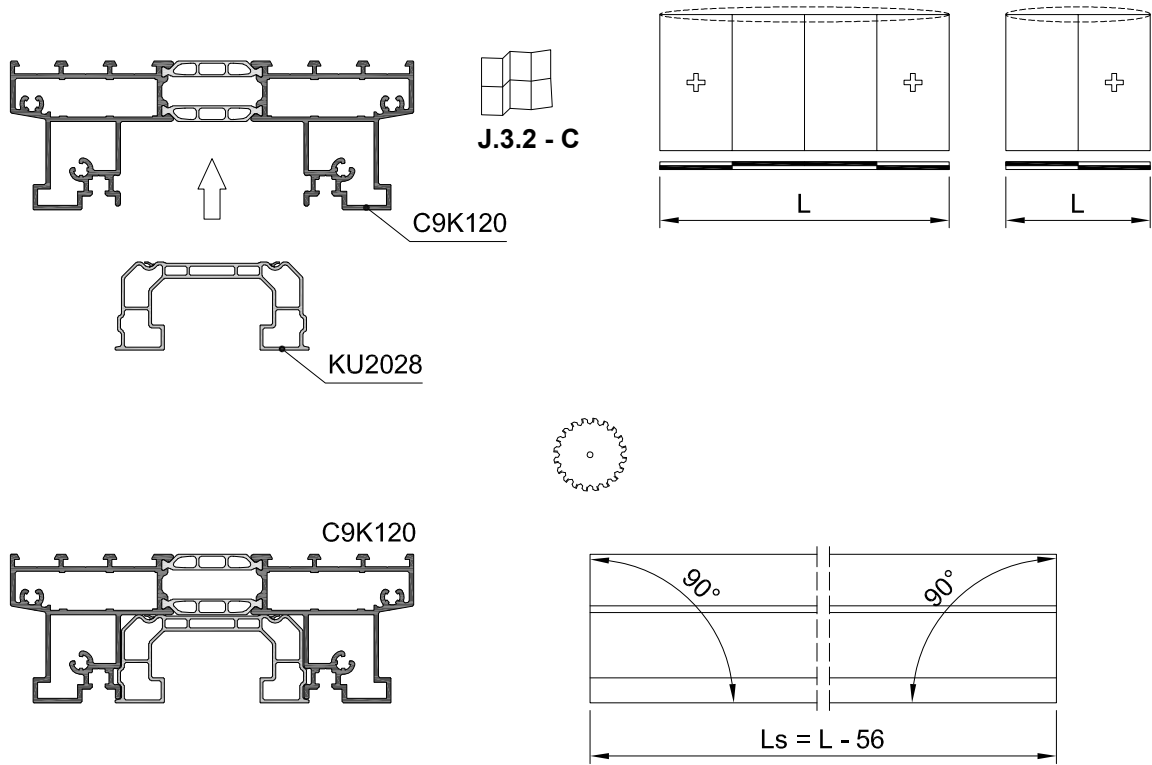

	BT6006
SHI	✓
SI	✓
I	x



1-BINARIO TELAI SOGLIA RIBASSATA TAGLIO 90°

TAGLIO DEL C9K100 + KU2035 E INSTALLAZIONE BT6017

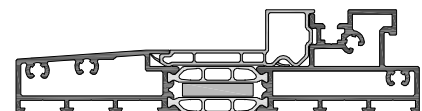
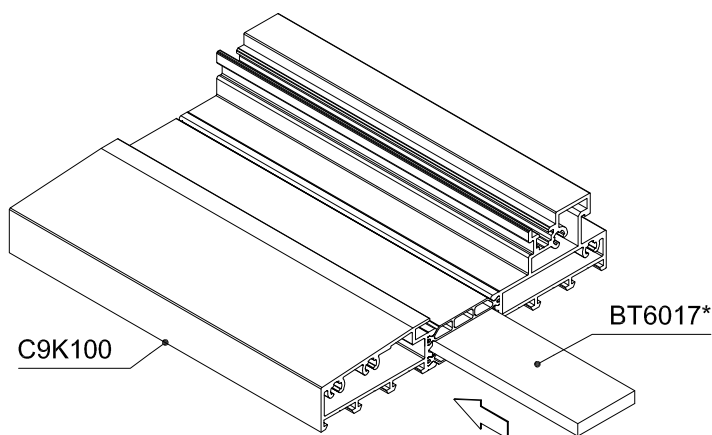
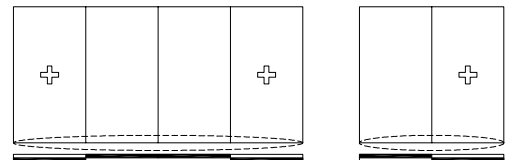
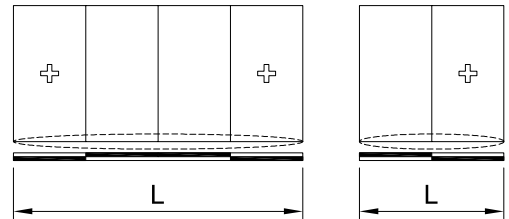
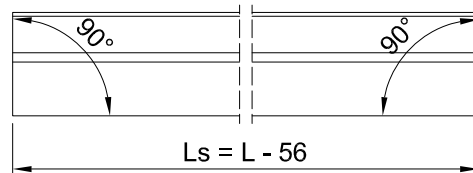
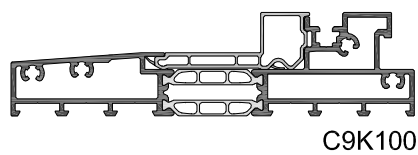
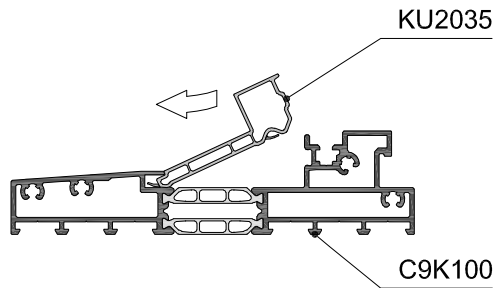

	BT6017
SHI	✓
SI	✓
I	x

PANORAMICA DRENAGGI.

1 / 12

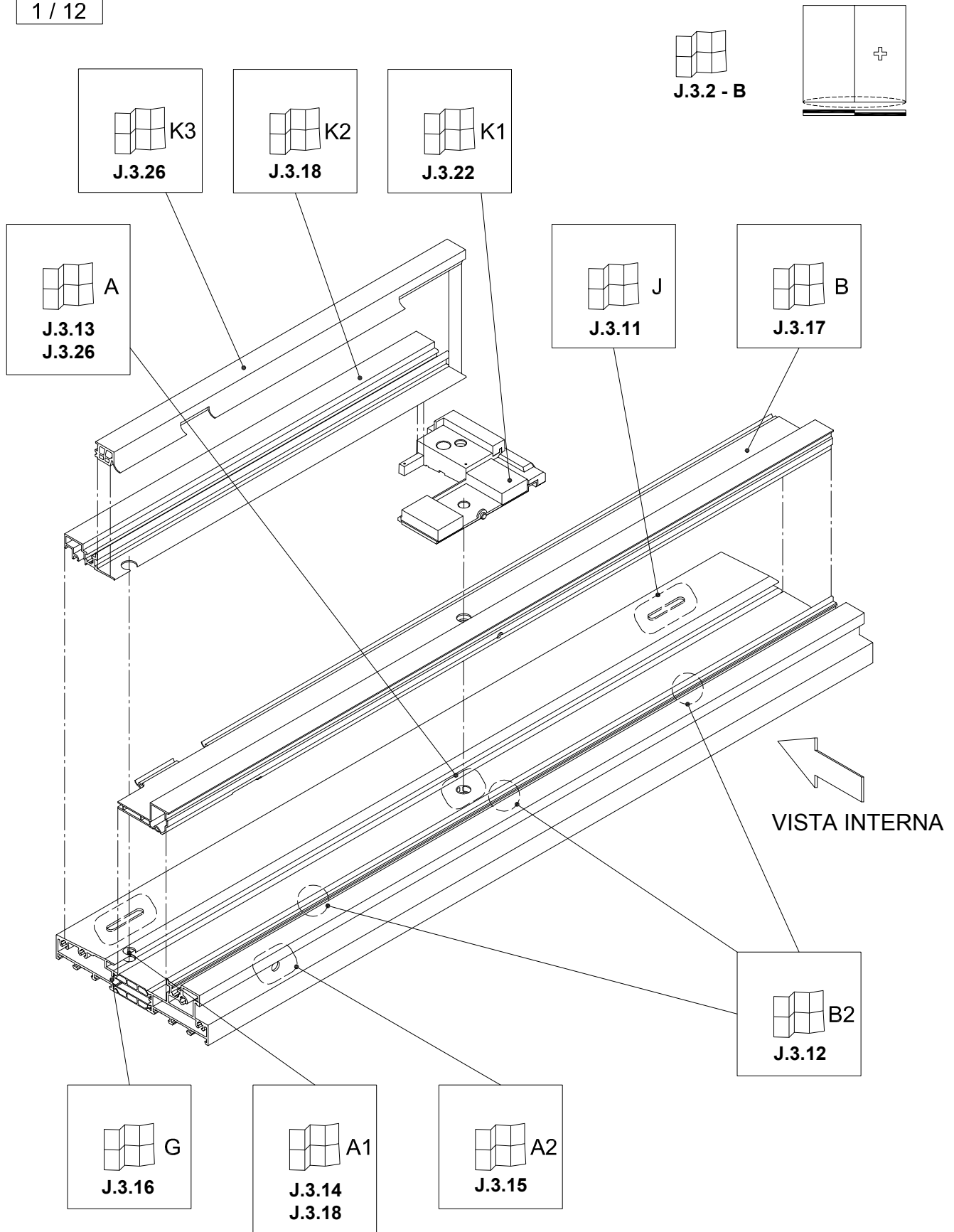



1-BINARIO TELAIO SOGLIA RIBASSATA TAGLIO 90°

C9K100 LAVORAZIONE DRENAGGIO - H

2 / 12

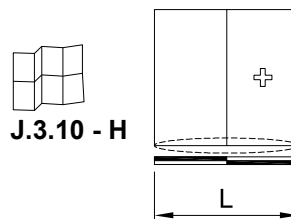

A-A

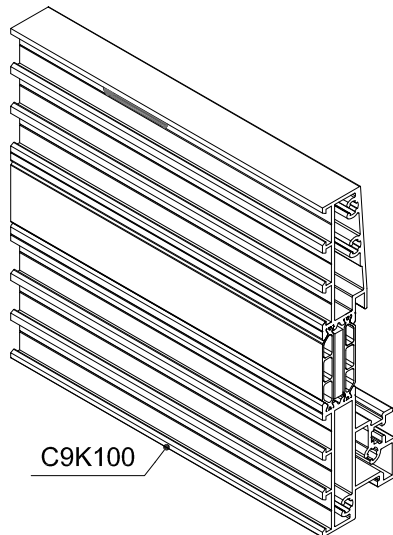
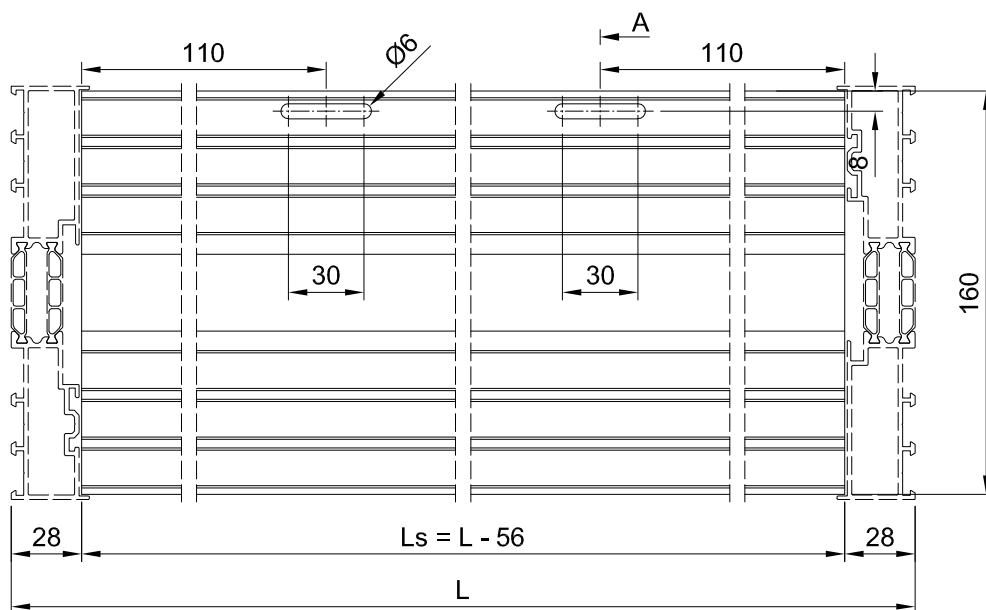
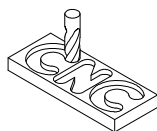
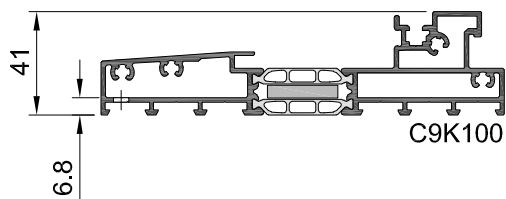

C9K100 LAVORAZIONE DRENAGGIO - B2

3 / 12

J.3.10 - B2

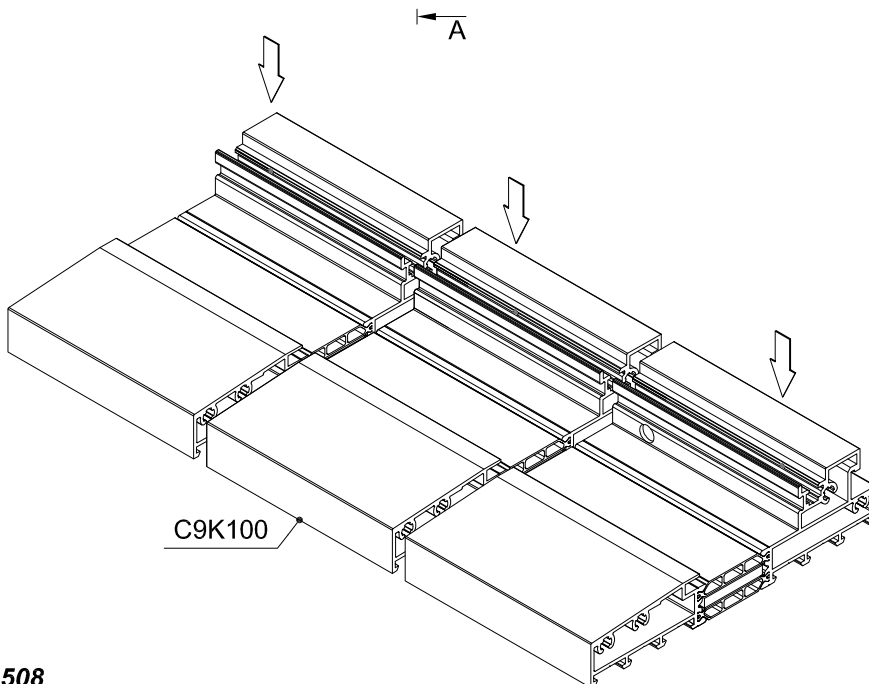
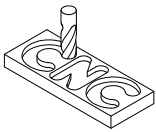
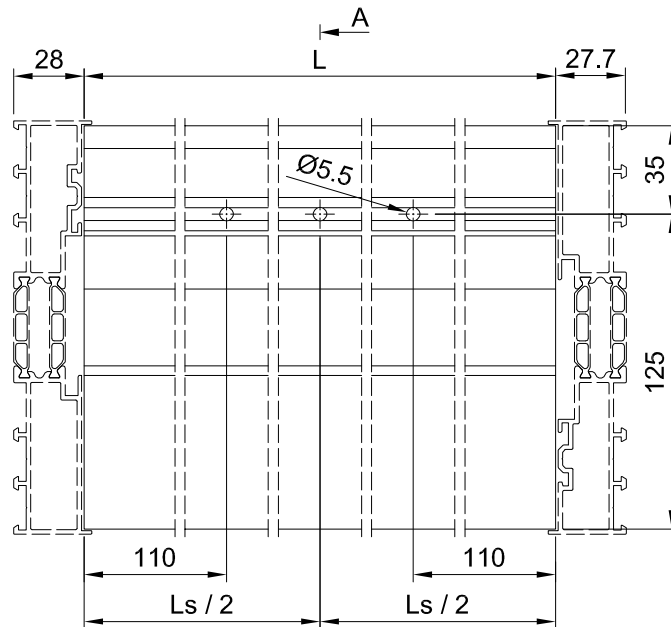
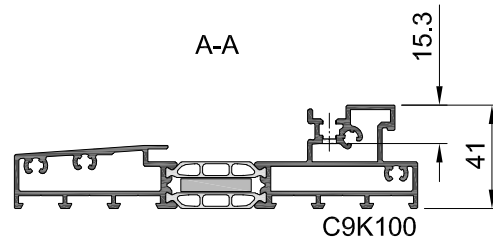
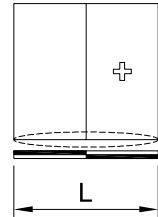



1-BINARIO TELAIÒ SOGLIA RIBASSATA TAGLIO 90°

C9K100 LAVORAZIONE DRENAGGIO - A

4 / 12



J.3.10 - A
J.3.26

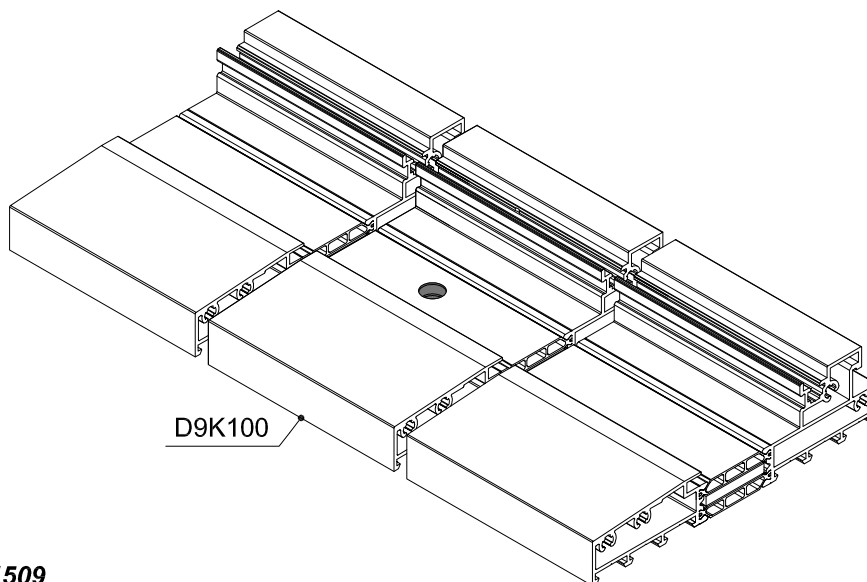
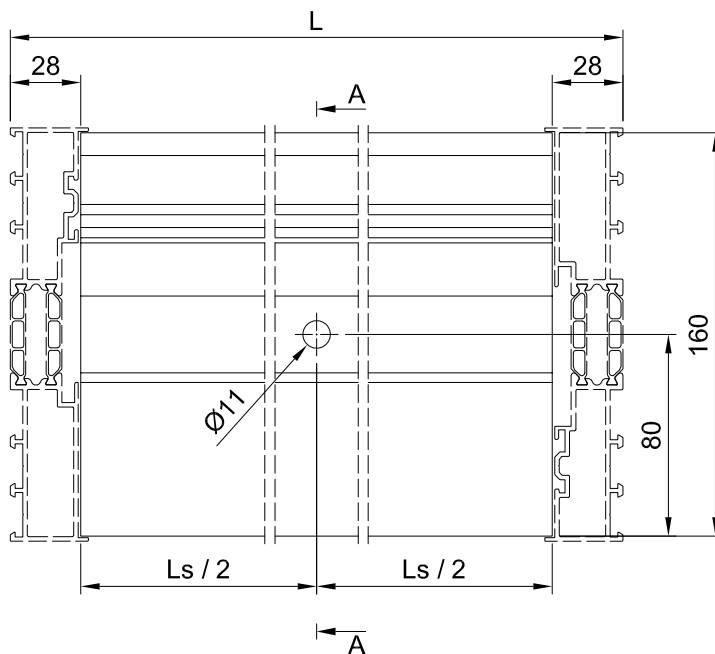
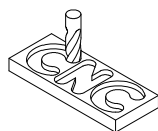
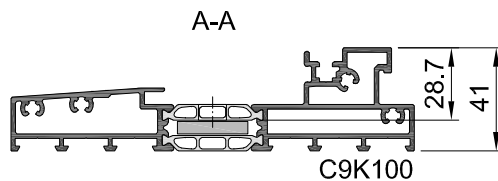
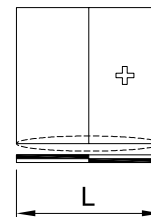

C9K100 LAVORAZIONE DRENAGGIO - A1

5 / 12

J.3.10 - A1
J.3.18

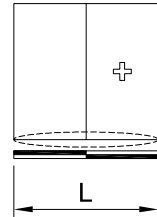

A-A

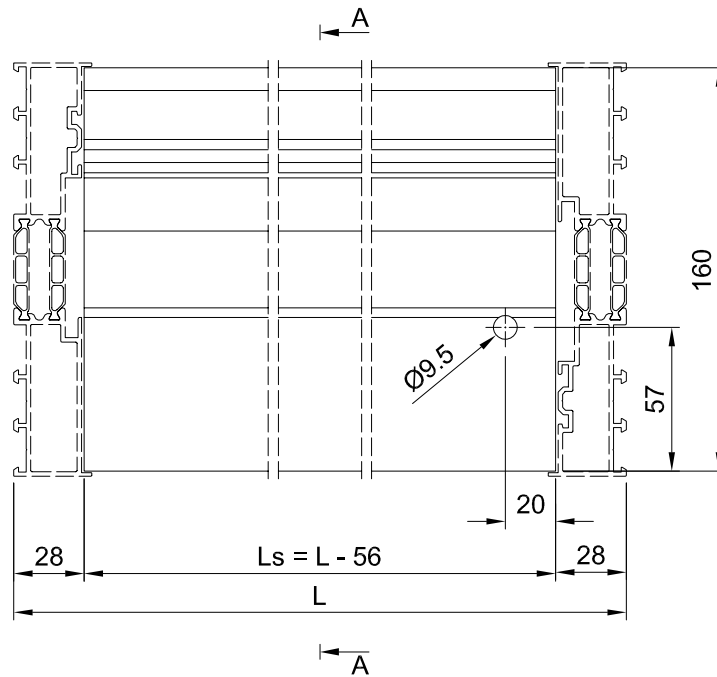
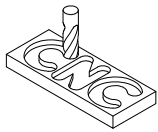
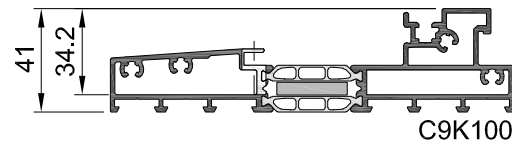

VISTA INTERNA

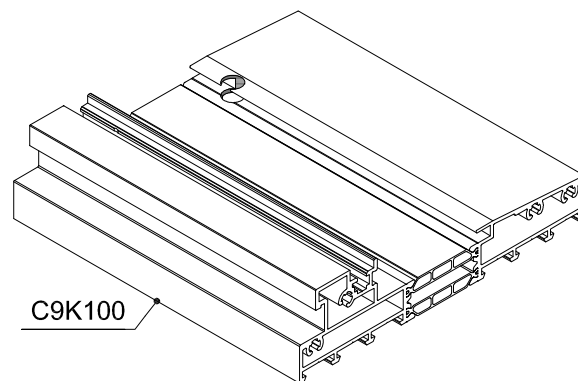



1-BINARIO TELAIIO SOGLIA RIBASSATA TAGLIO 90°

C9K100 LAVORAZIONE DRENAGGIO - A2

6 / 12



J.3.10 - A2

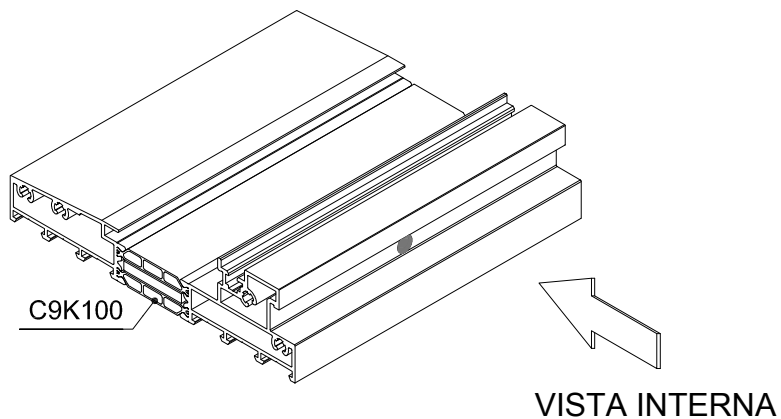
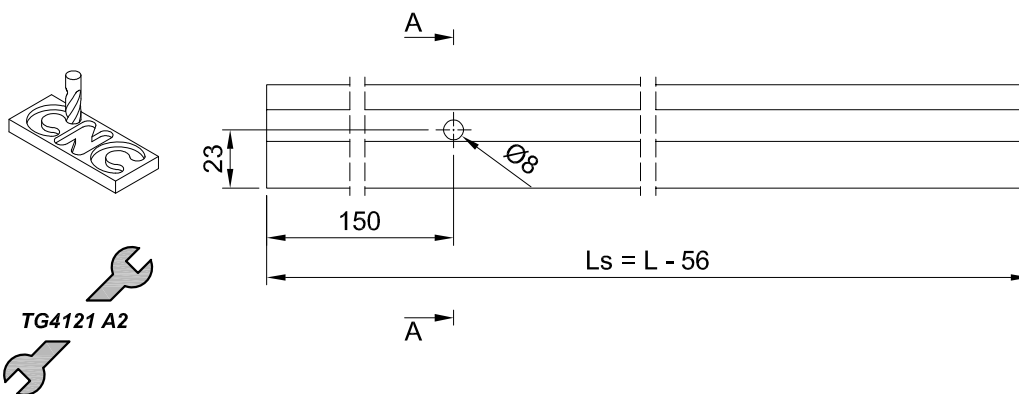
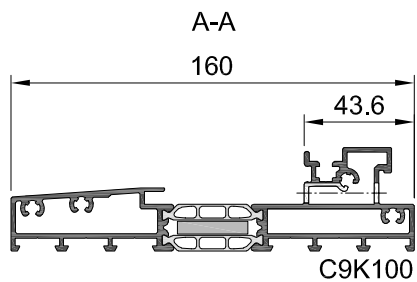
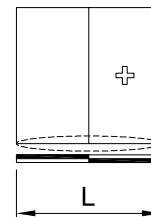

C9K100 LAVORAZIONE DRENAGGIO - G

7 / 12



J.3.10 - G

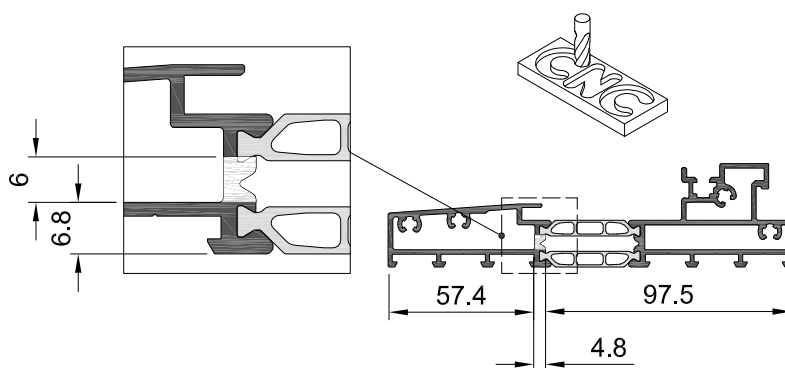
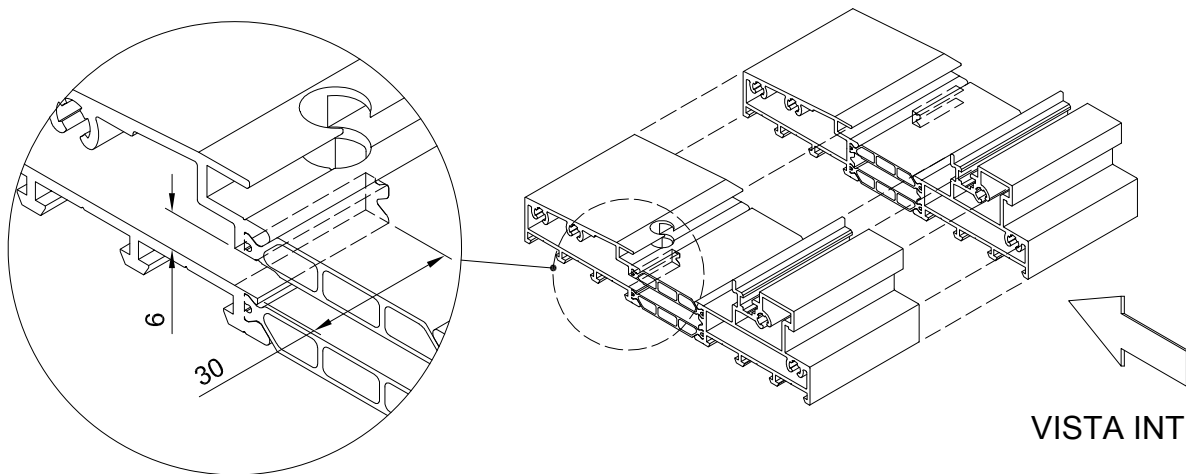
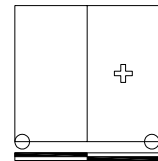



1-BINARIO TELAIO SOGLIA RIBASSATA TAGLIO 90°

KU2035 LAVORAZIONE DRENAGGIO - B

8 / 12

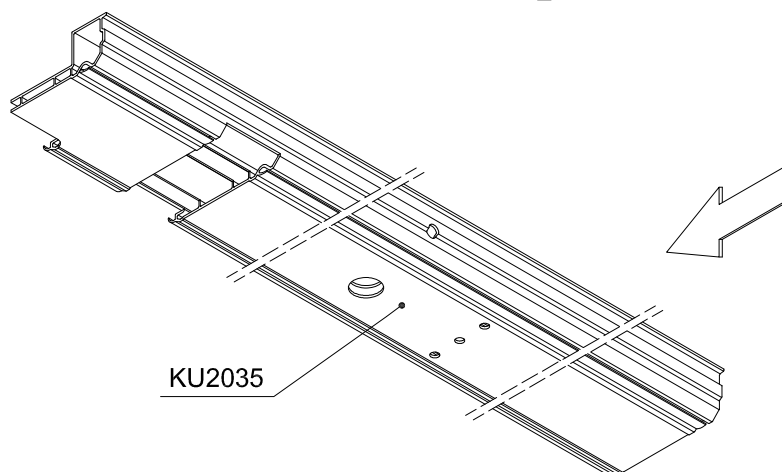
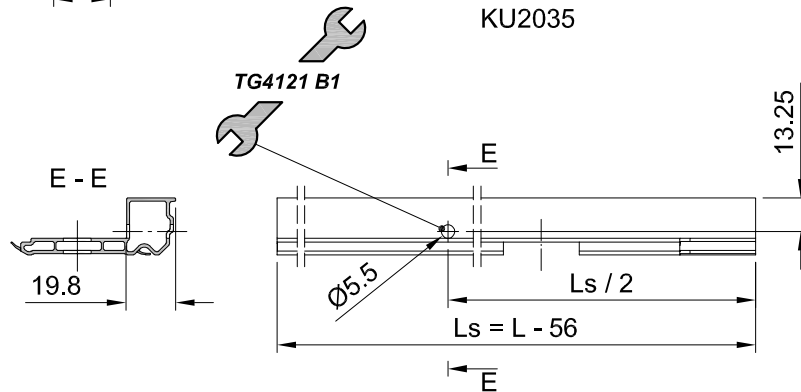
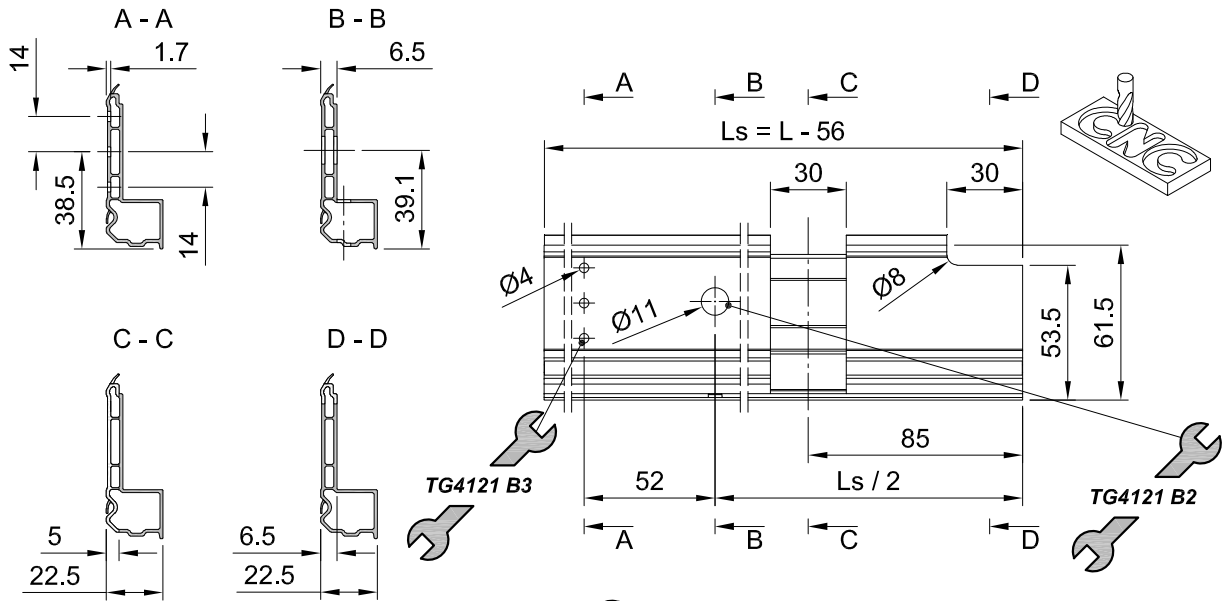
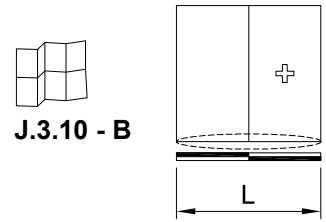

INSTALLAZIONE VS0107

9 / 12



J.3.10 - A1
J.3.14

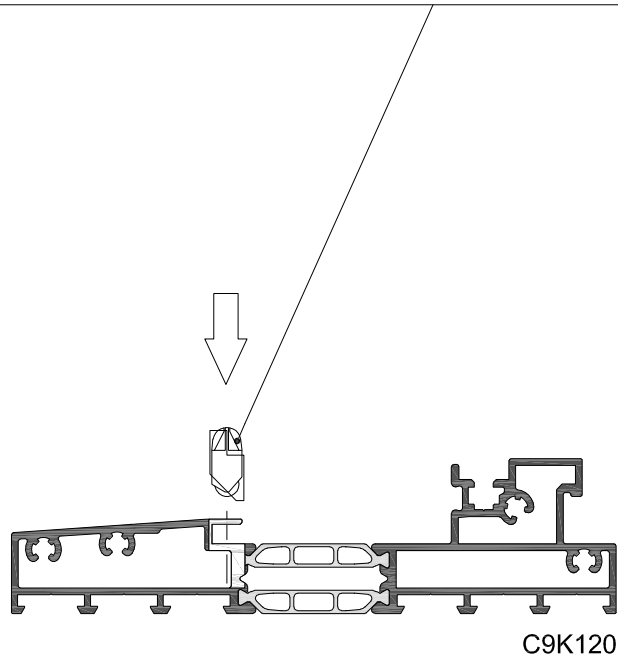
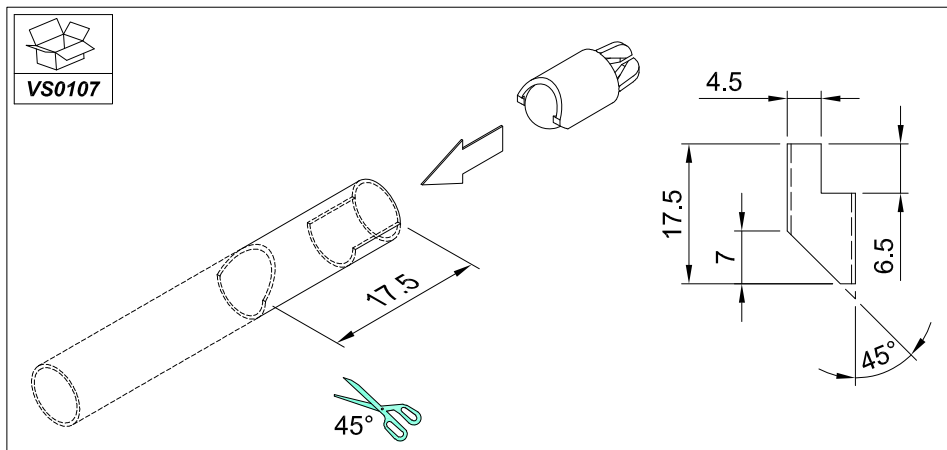
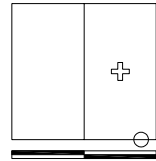



1-BINARIO TELAIO SOGLIA RIBASSATA TAGLIO 90°

SIGILLATURA KU2035

10 / 12



J.3.10

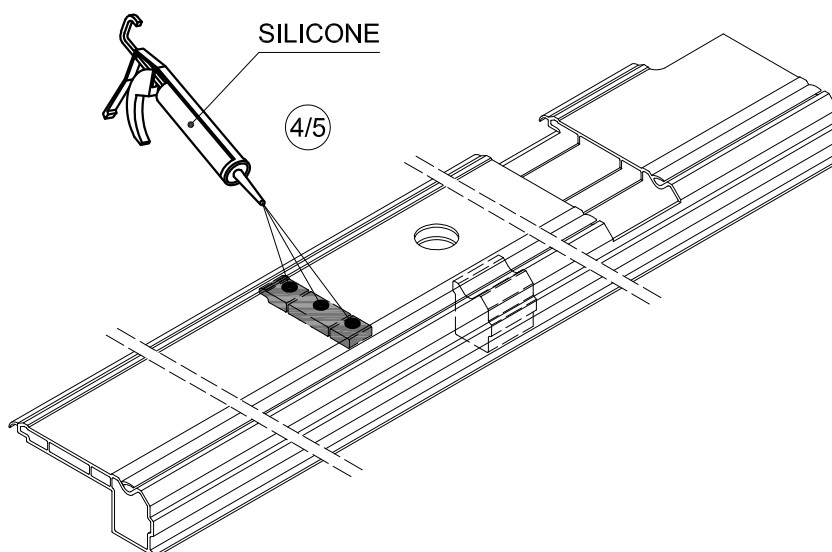
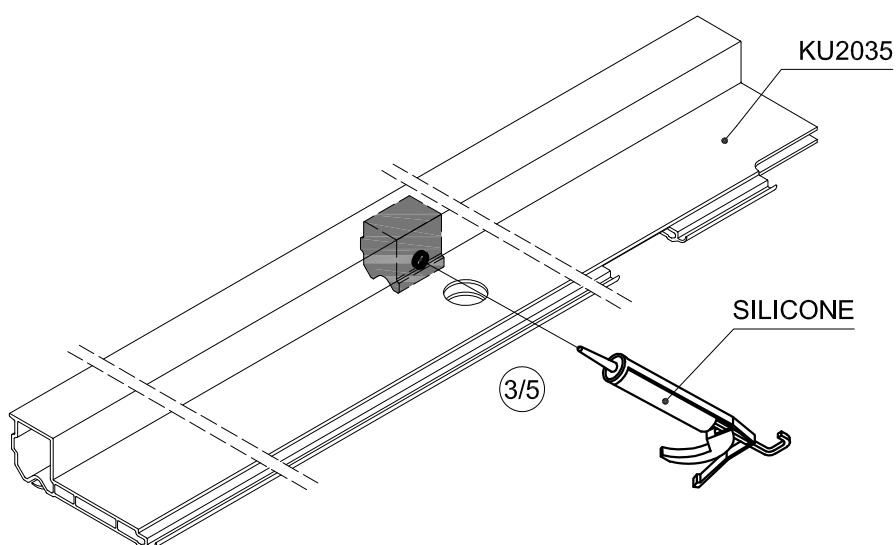
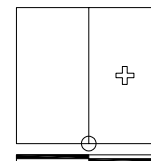

SIGILLATURA CENTRALE DEL C9K100 PER ASSEMBLAGGIO CON KU2035

11 / 12

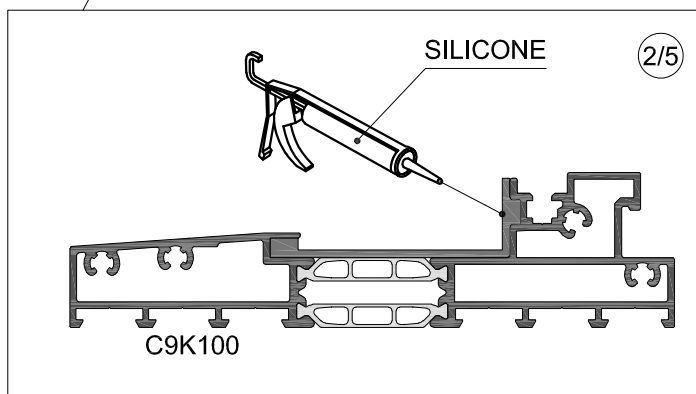
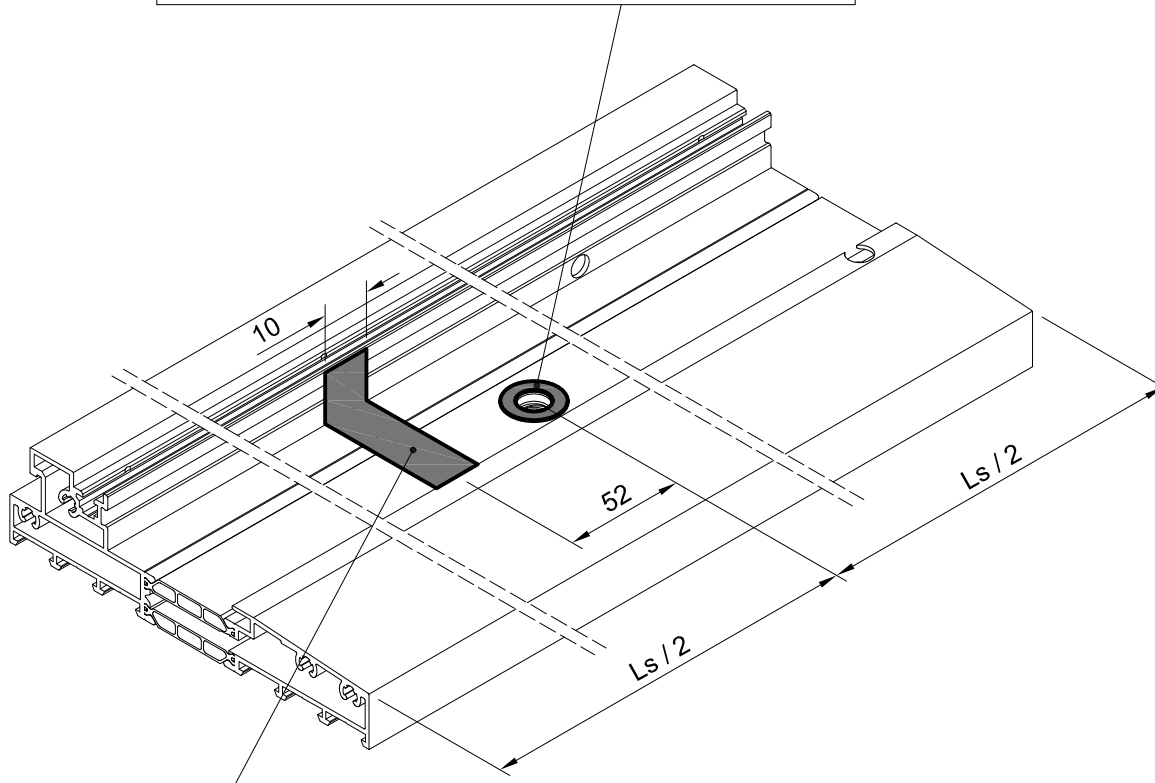
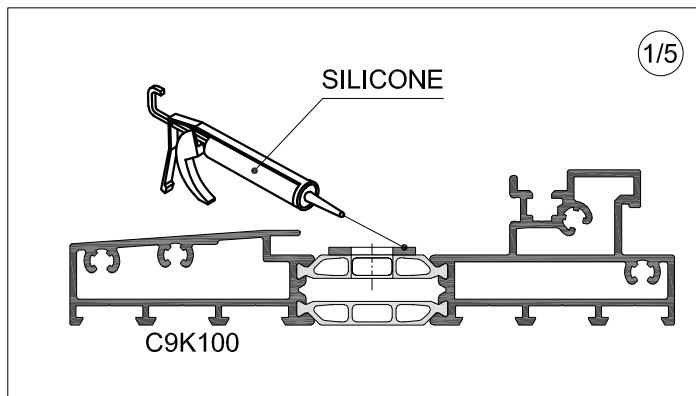
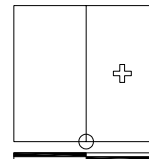
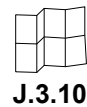



1-BINARIO TELAIIO SOGLIA RIBASSATA TAGLIO 90°

INSTALLAZIONE KU2035 SU C9K100

12 / 12



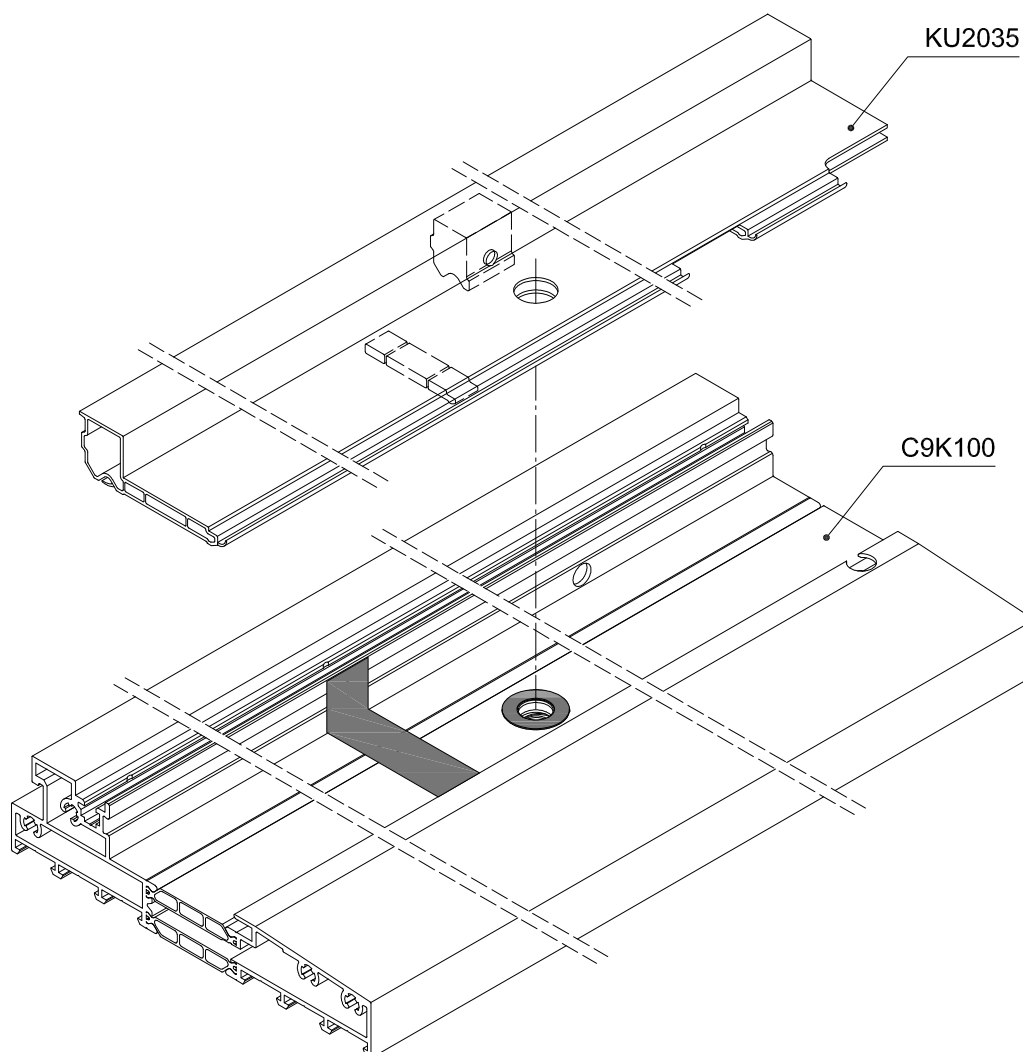
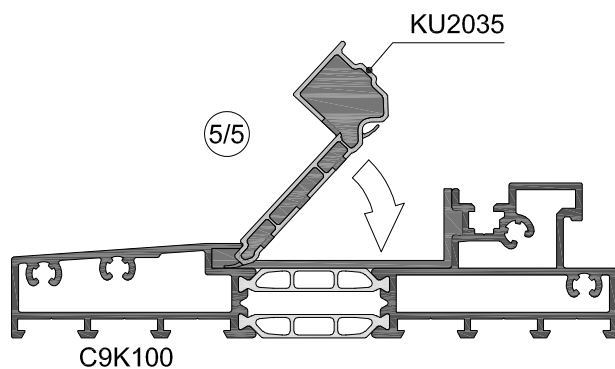
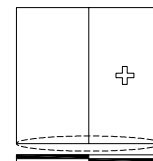

J.3.10

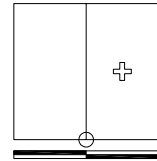

INSTALLAZIONE SIGILLATURA CENTRALE INFERIORE

1 / 5



RIGHT acc. EN 12519:2004	 CO1136
LEFT acc. EN 12519:2004	 CO1137

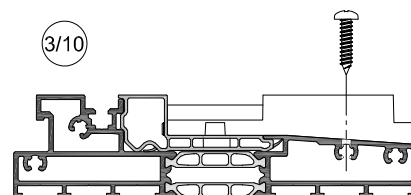
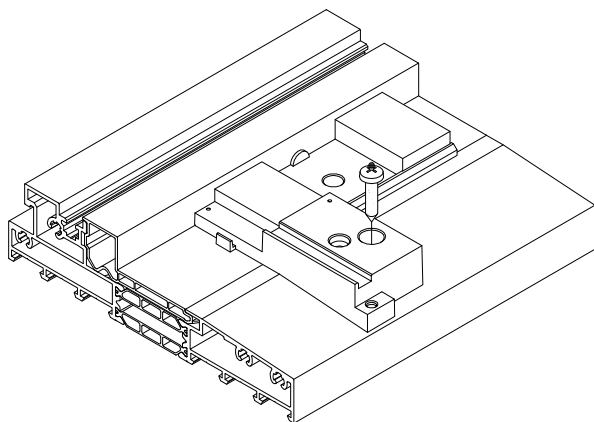
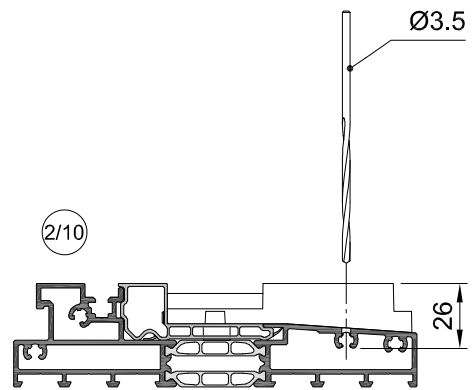
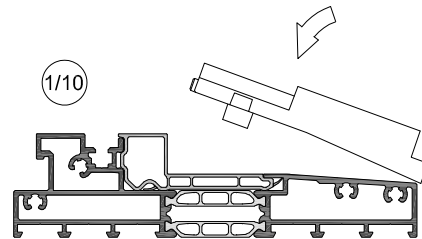
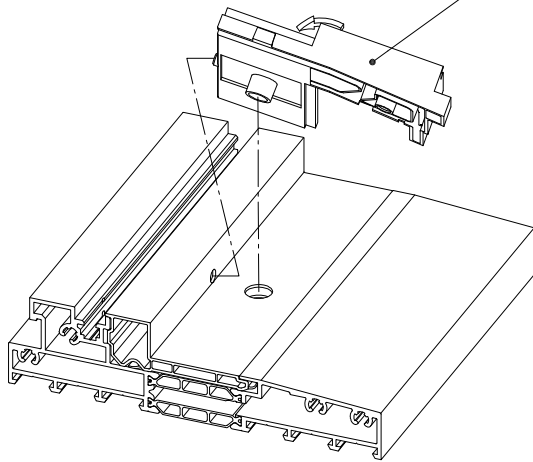



1-BINARIO TELAIO SOGLIA RIBASSATA TAGLIO 90°

C9A101 LAVORAZIONE DRENAGGIO - K2

2 / 5



J.3.2 - D
J.3.10 - K2

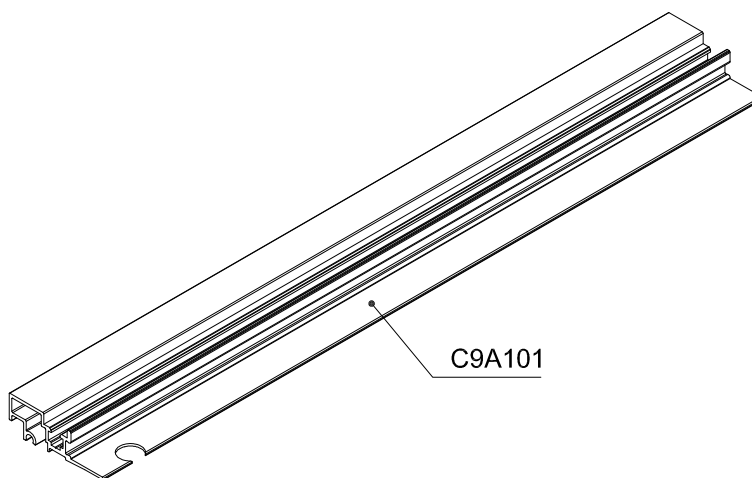
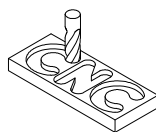
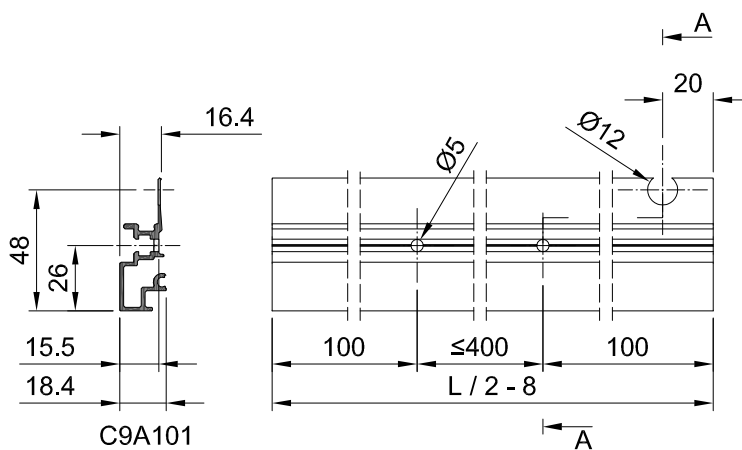
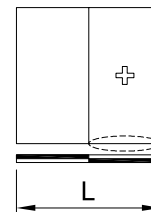

INSTALLAZIONE C9A101

3 / 5



J.3.10 -
K2

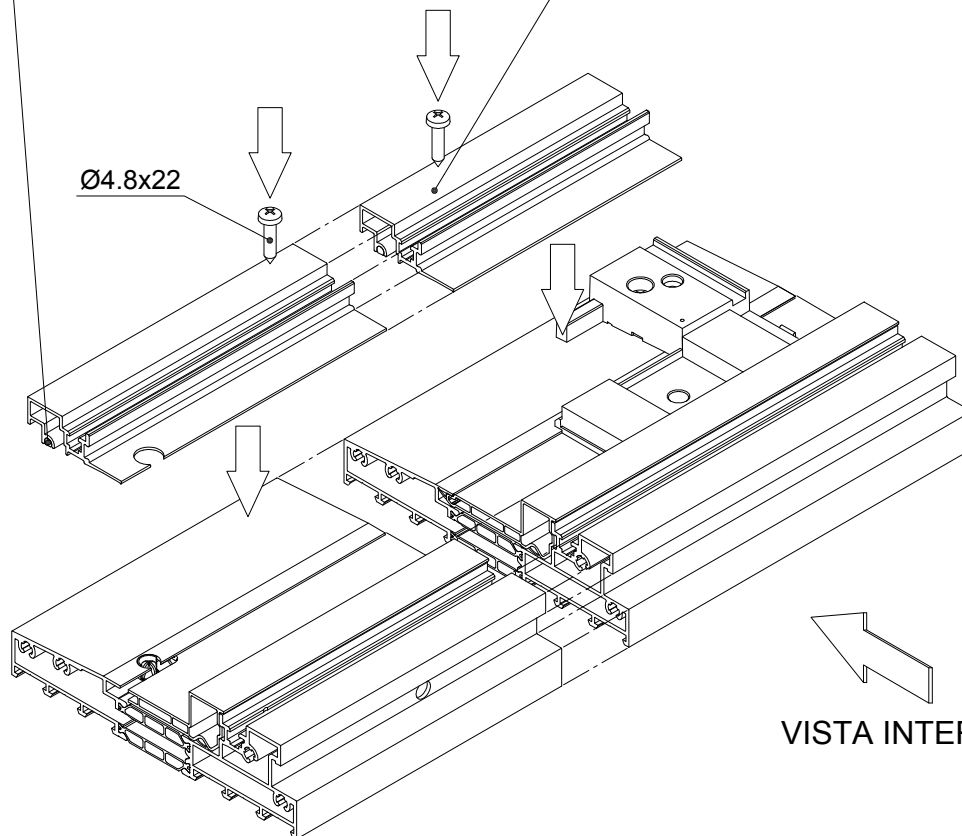
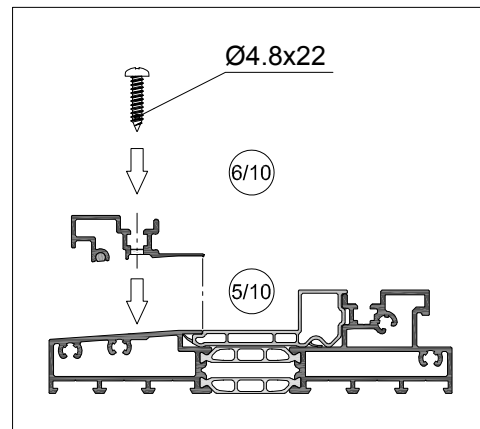
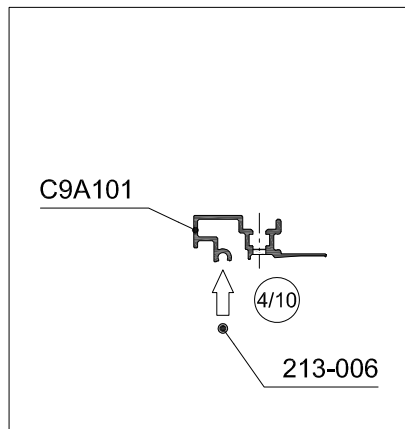
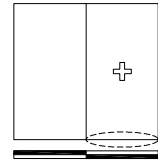

VISTA INTERNA



1-BINARIO TELAIO SOGLIA RIBASSATA TAGLIO 90°

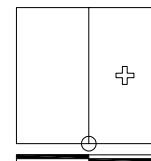

INSTALLAZIONE E SIGILLATURA

4 / 5

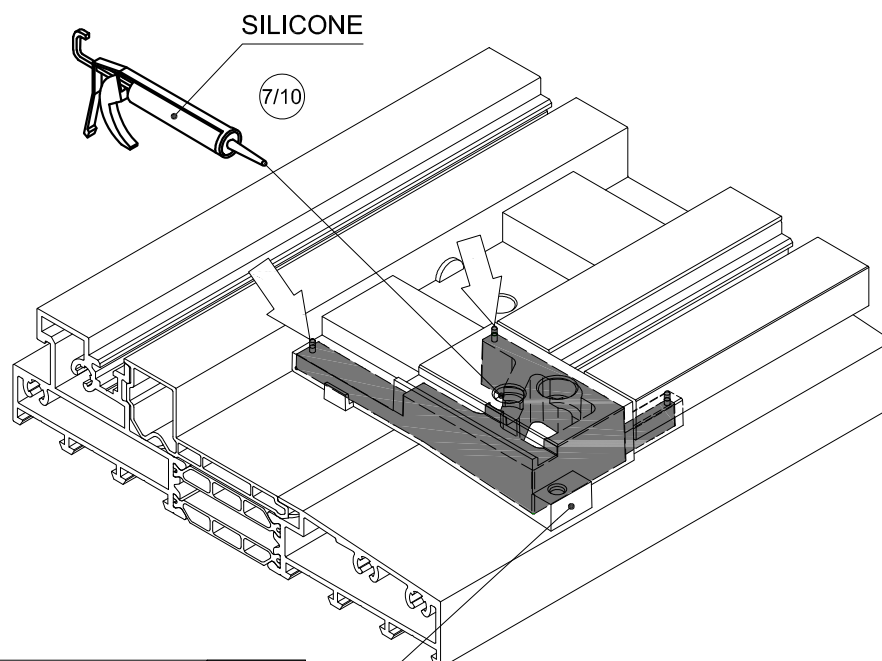

J.3.2 - D
J.3.10 - K2





RIGHT acc. EN 12519:2004	 CO1136
LEFT acc. EN 12519:2004	 CO1137

INSTALLAZIONE RU9131 + RU9704 + VS0107 + CO1137

5 / 5

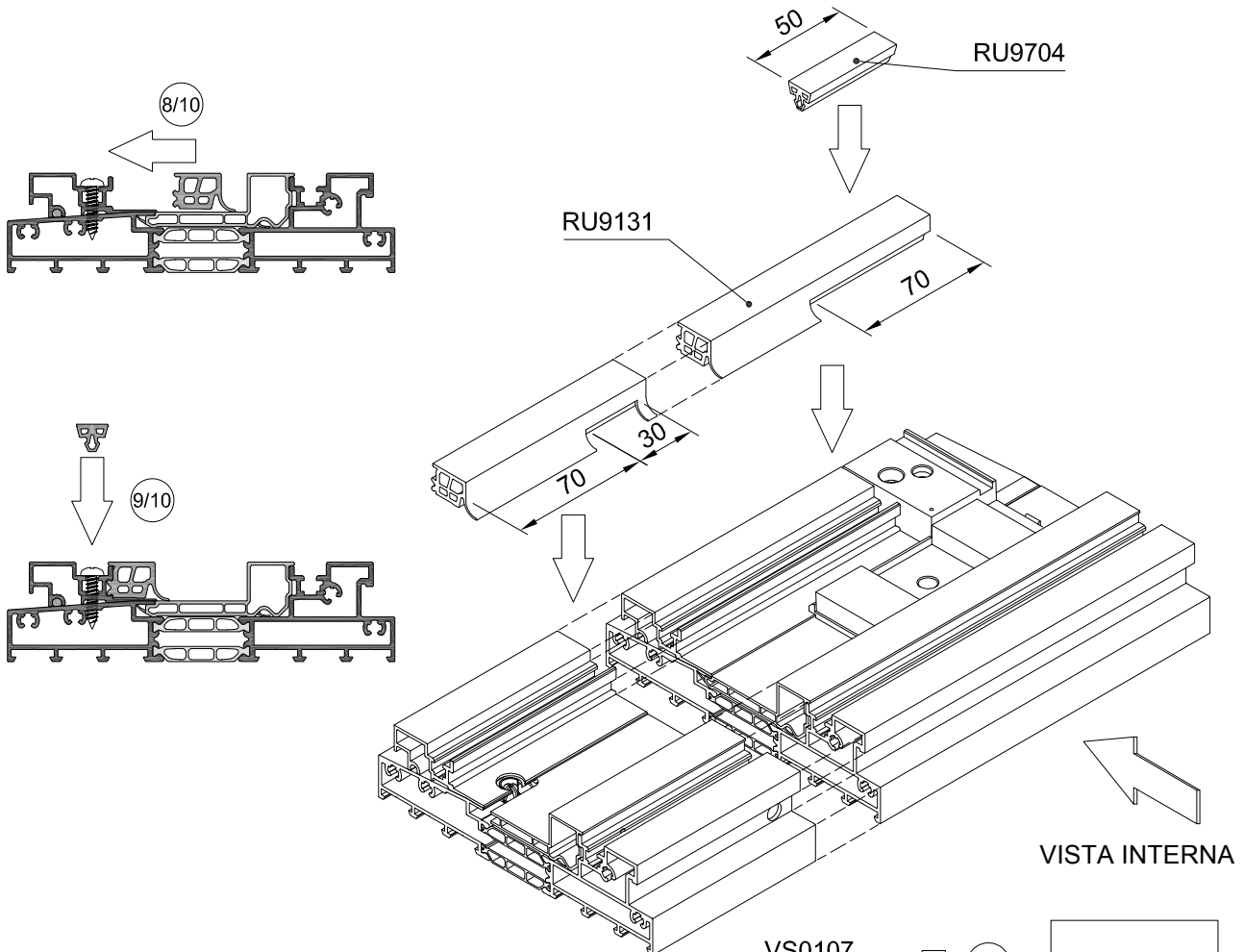
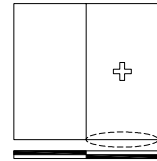
J.3.2 - D
J.3.10 - K1, K3



RIGHT acc. EN 12519:2004	 CO1136
LEFT acc. EN 12519:2004	 CO1137

VS0107

10/10

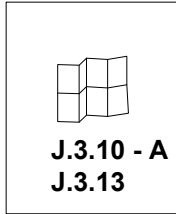



1-BINARIO TELAI0 SOGLIA RIBASSATA TAGLIO 90°

ANTA FISSA SOGLIA RIBASSATA - LAVORAZIONE PROFILATO CARTELLINA SPECIALE



J.9.8
J.10.23

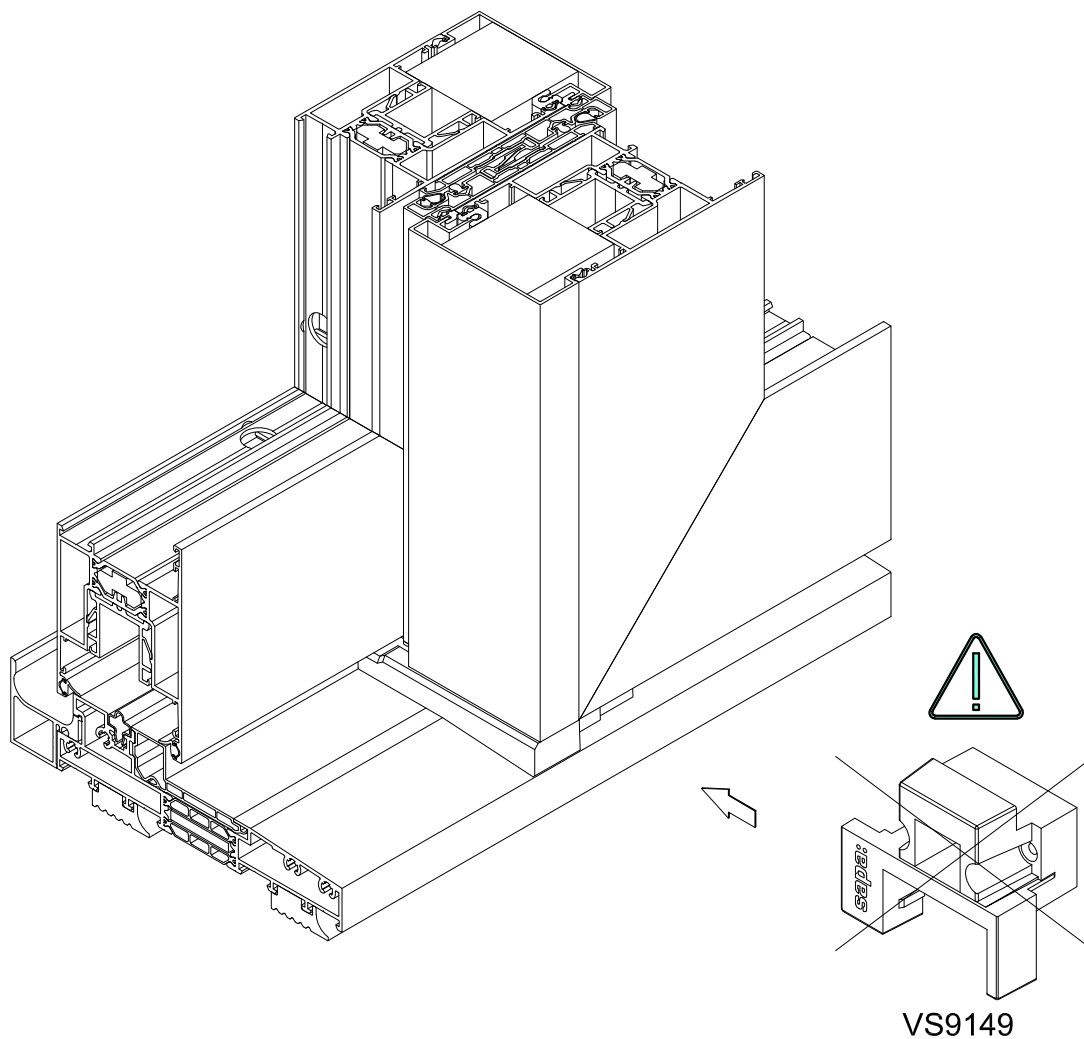
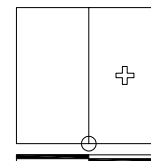

INSTALLAZIONE CO1111 TAPPO SIGILLATURA CENTRALE SUPERIORE

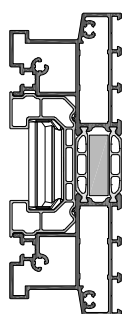
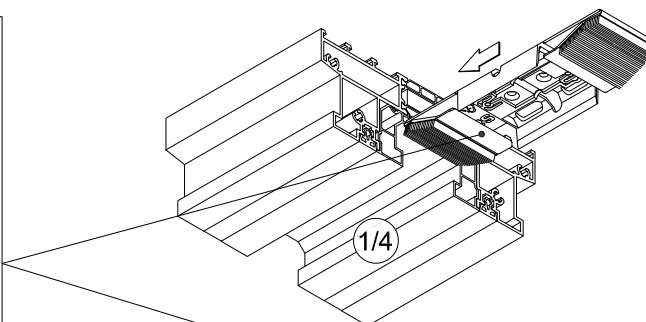
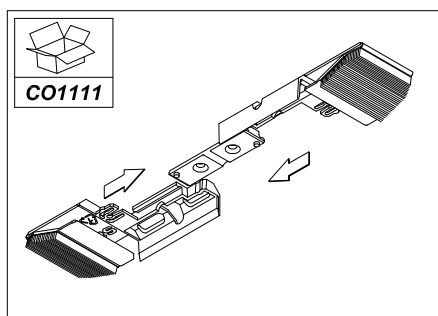
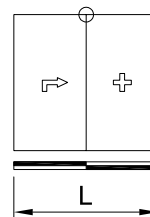

C9K120

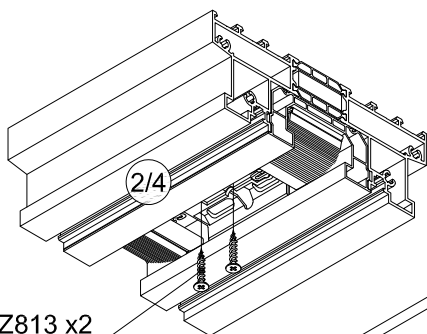
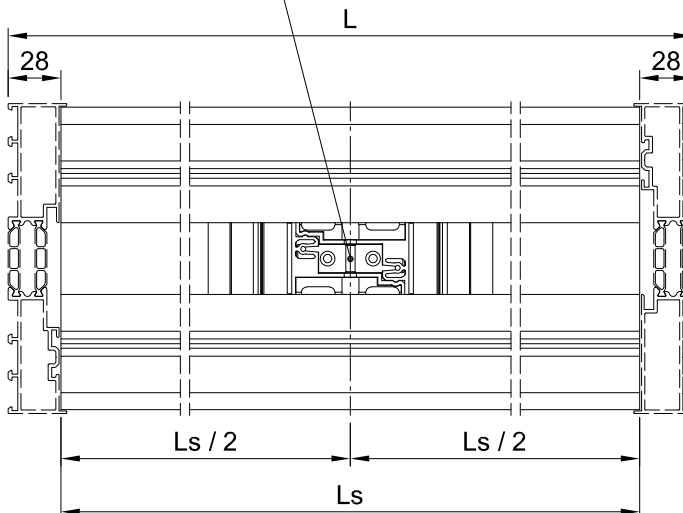

SCZ813 x2

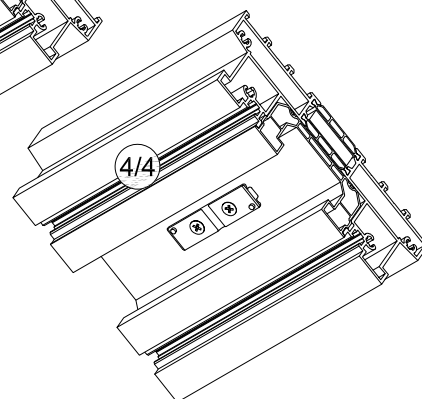
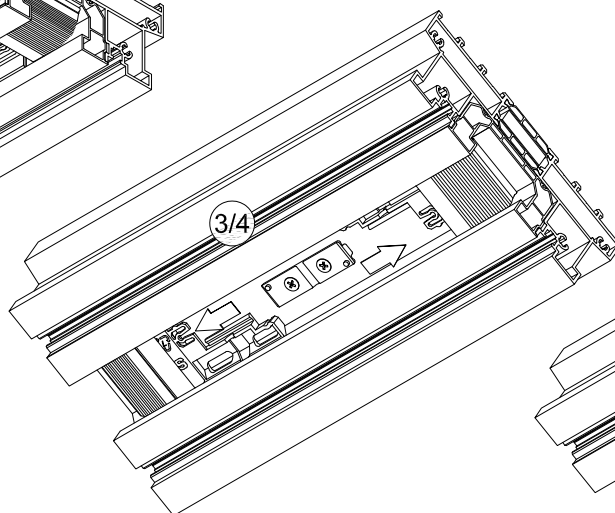

C160-ASS-1552



1-BINARIO TELAIÒ SOGLIA RIBASSATA TAGLIO 90°

INSTALLAZIONE CONNESSIONI INFERIORI CO0132 E VS9957 SU C9K121

1 / 5



J.3.2 - A
J.3.5

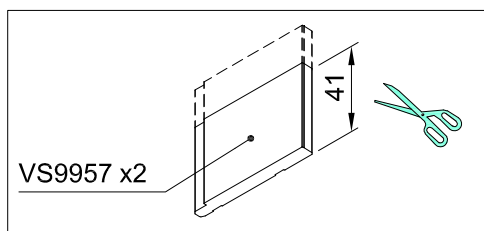
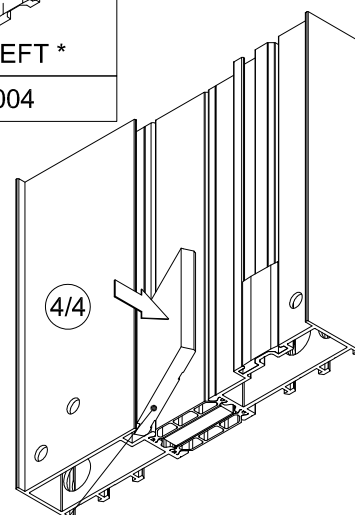
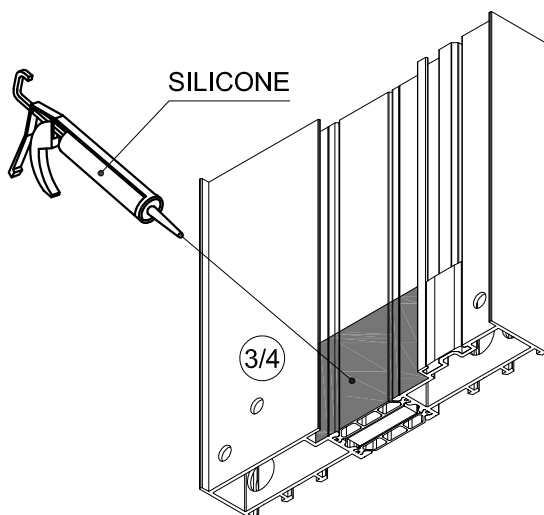
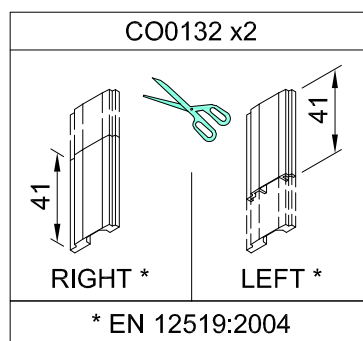
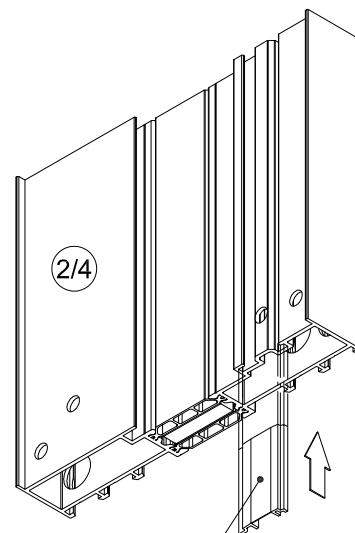
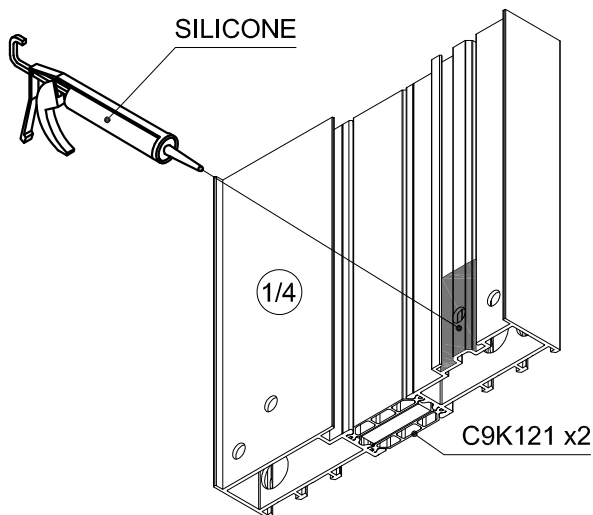
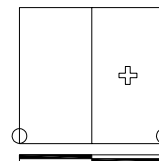

INSTALLAZIONE CONNESSIONI SUPERIORI CO0132 E VS9957 SU C9K121

2 / 5



J.3.2 - A
J.3.5

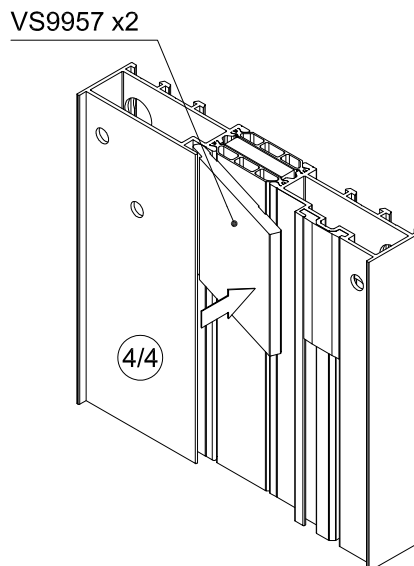
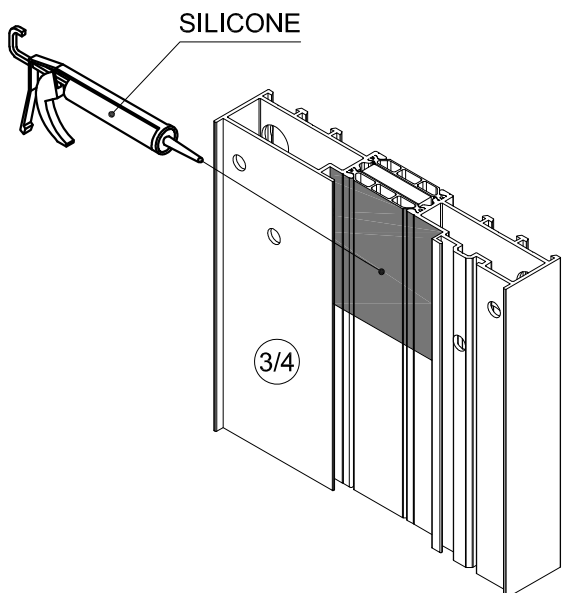
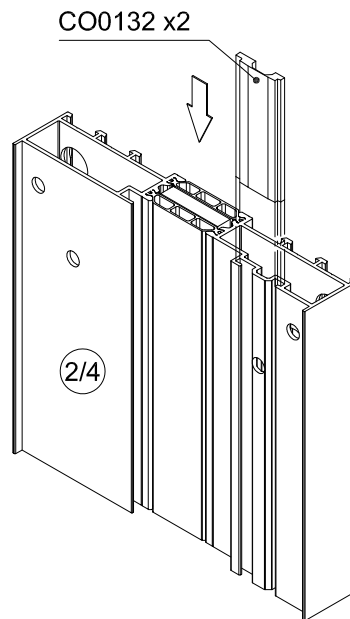
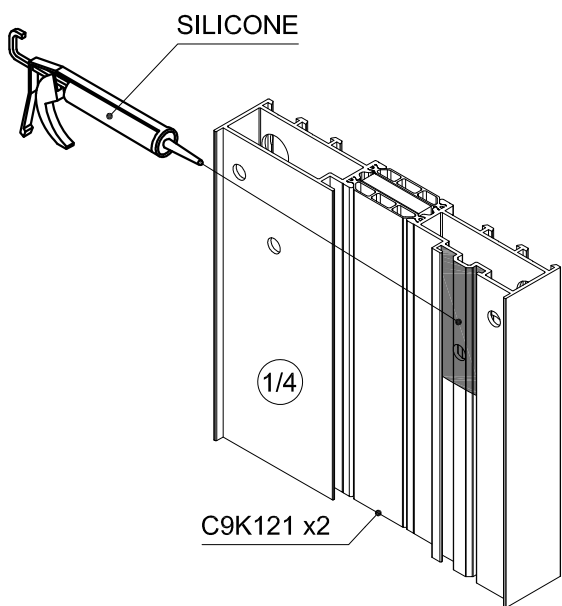
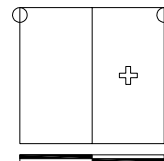



1-BINARIO TELAIO SOGLIA RIBASSATA TAGLIO 90°

INSTALLAZIONE VS9956 E VS9970 SU ANTA FISSA LATERALE

3 / 5



J.3.2 - A
J.3.6

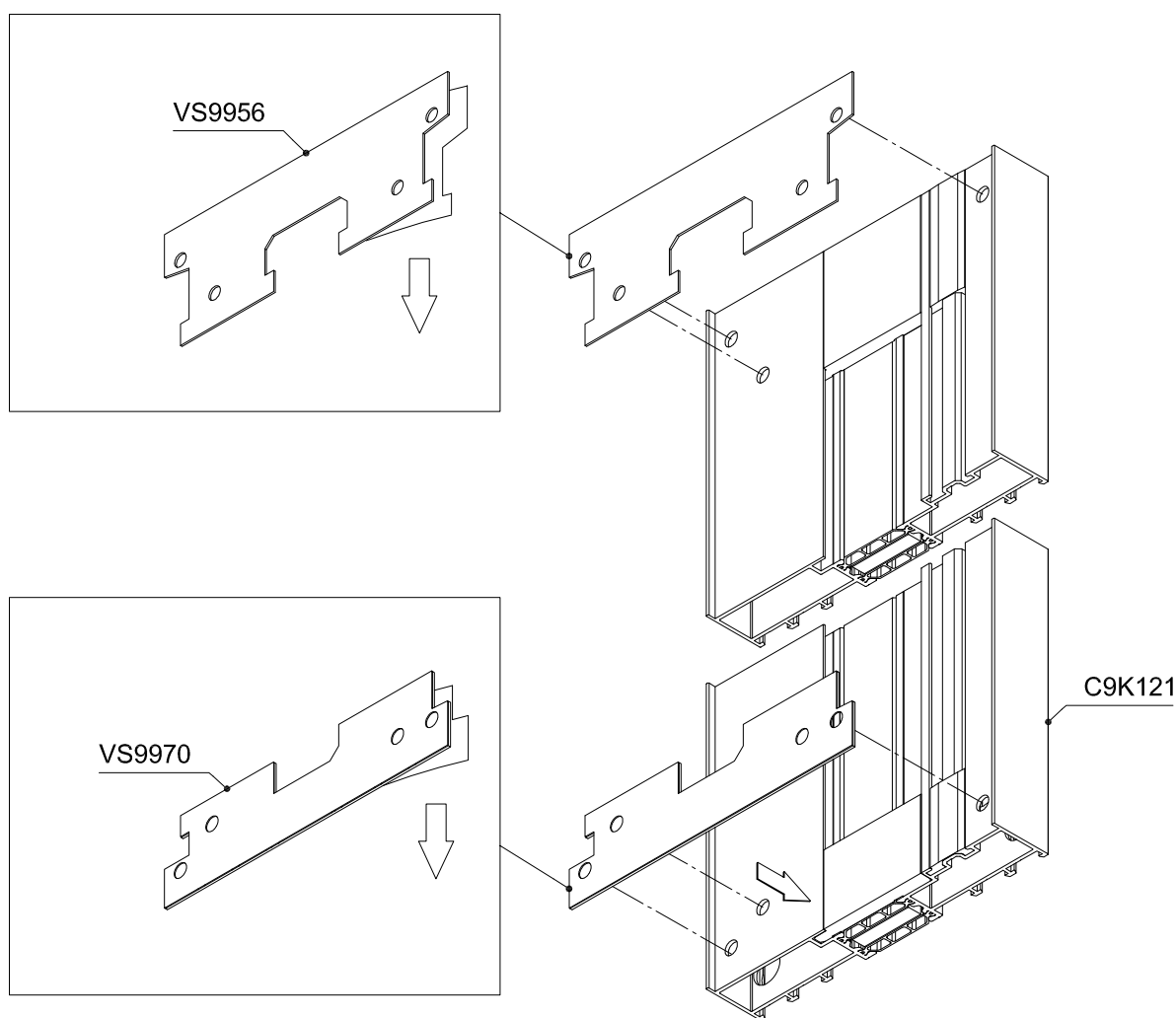
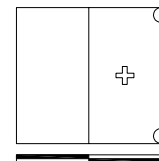

INSTALLAZIONE VS9956 E VS9970 SU ANTA MOBILE LATERALE

4 / 5

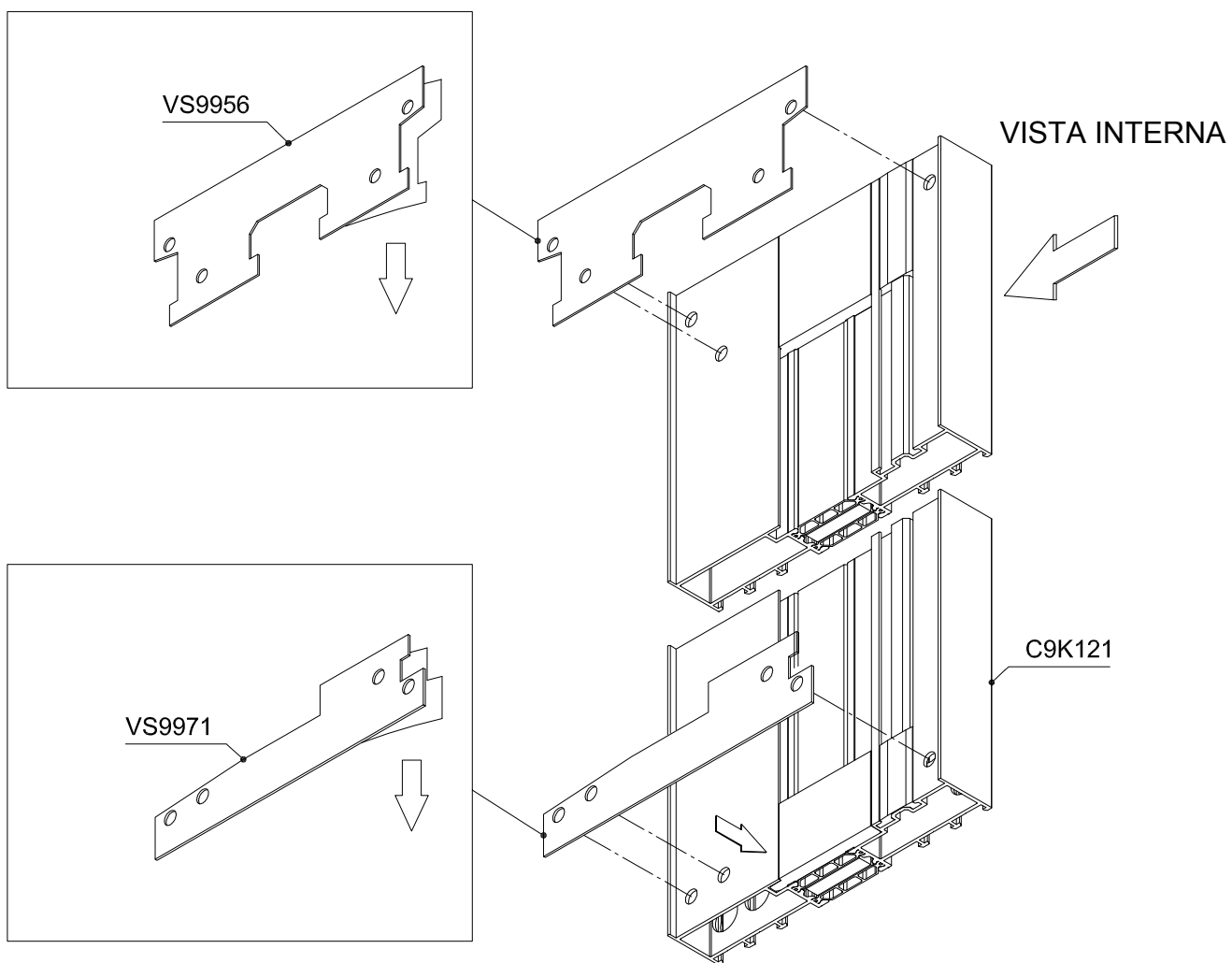
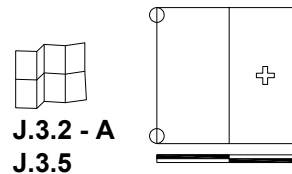



1-BINARIO TELAI0 SOGLIA RIBASSATA TAGLIO 90°

MONTAGGIO SU TELAI0

5 / 5



J.3.2 - A
J.3.5

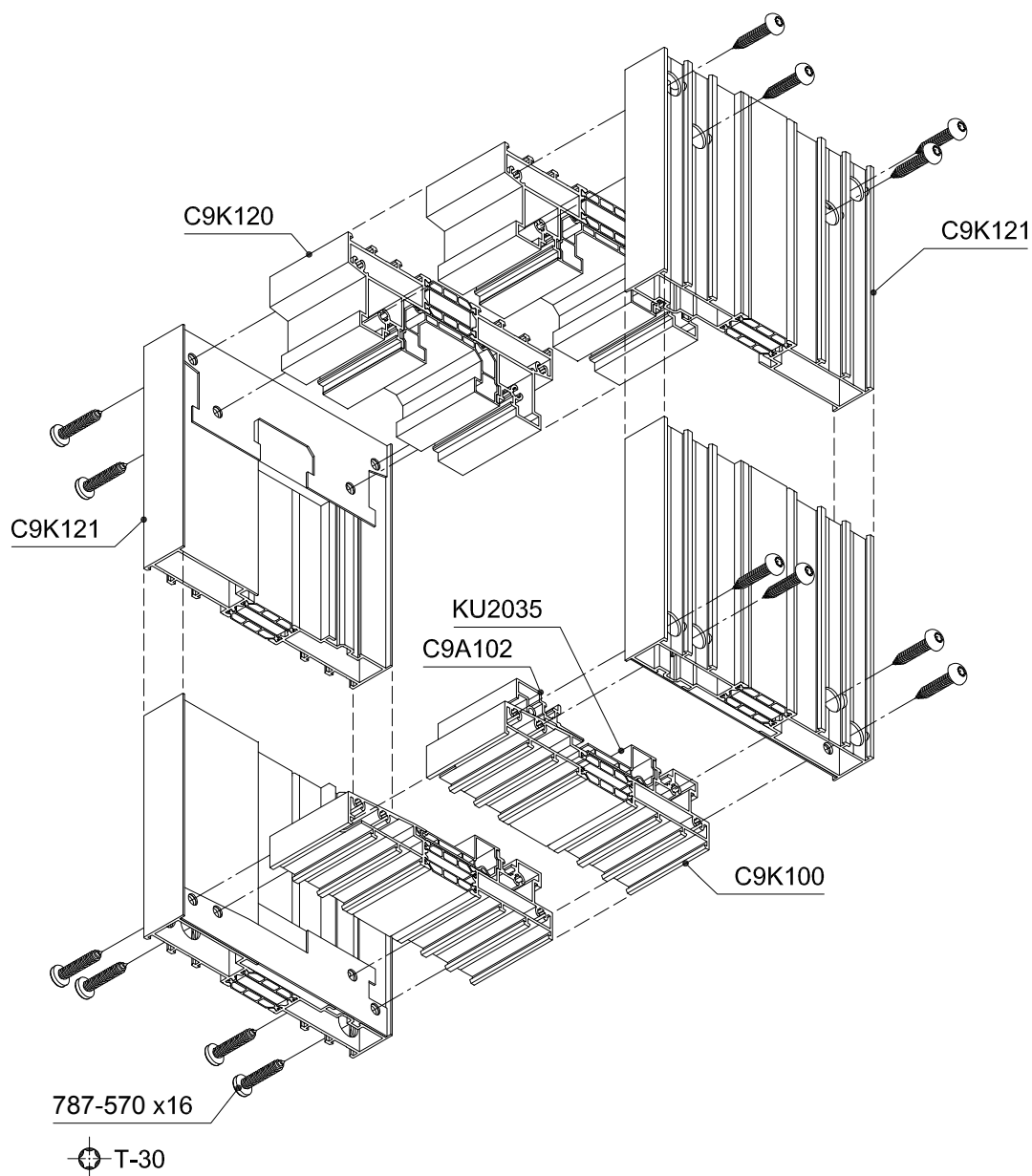
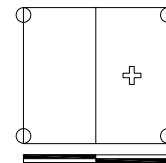

BLOCCHETTI CHIUSURA ALZANTE-SCORREVOLE SU C9A100 (ZB0034/ZB0035/ZB0036)

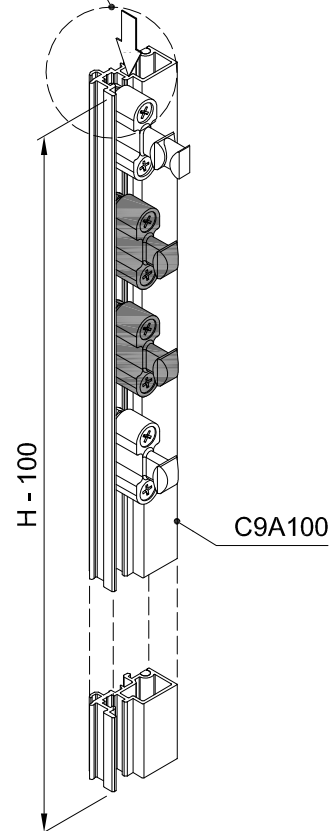
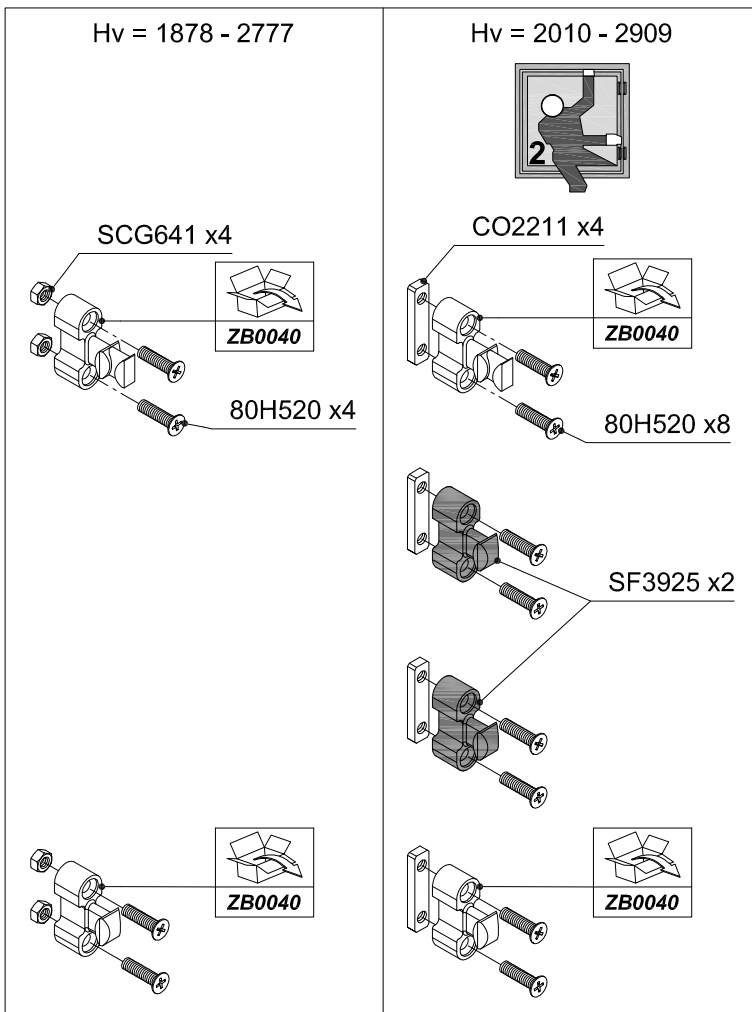
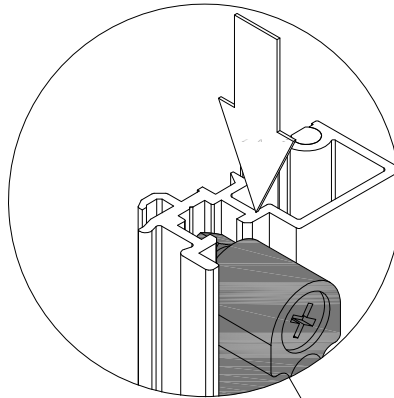
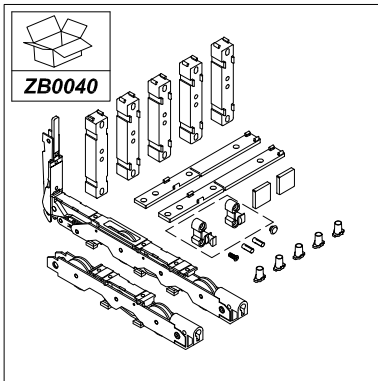
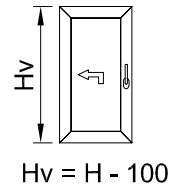
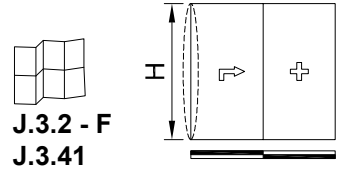



1-BINARIO TELAI SOGLIA RIBASSATA TAGLIO 90°

SIGILLATURA ANGOLI CON RU9704

1 / 4



J.3.2 - G

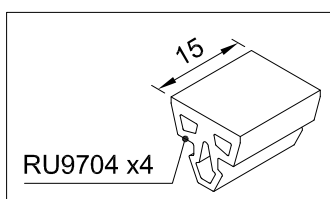
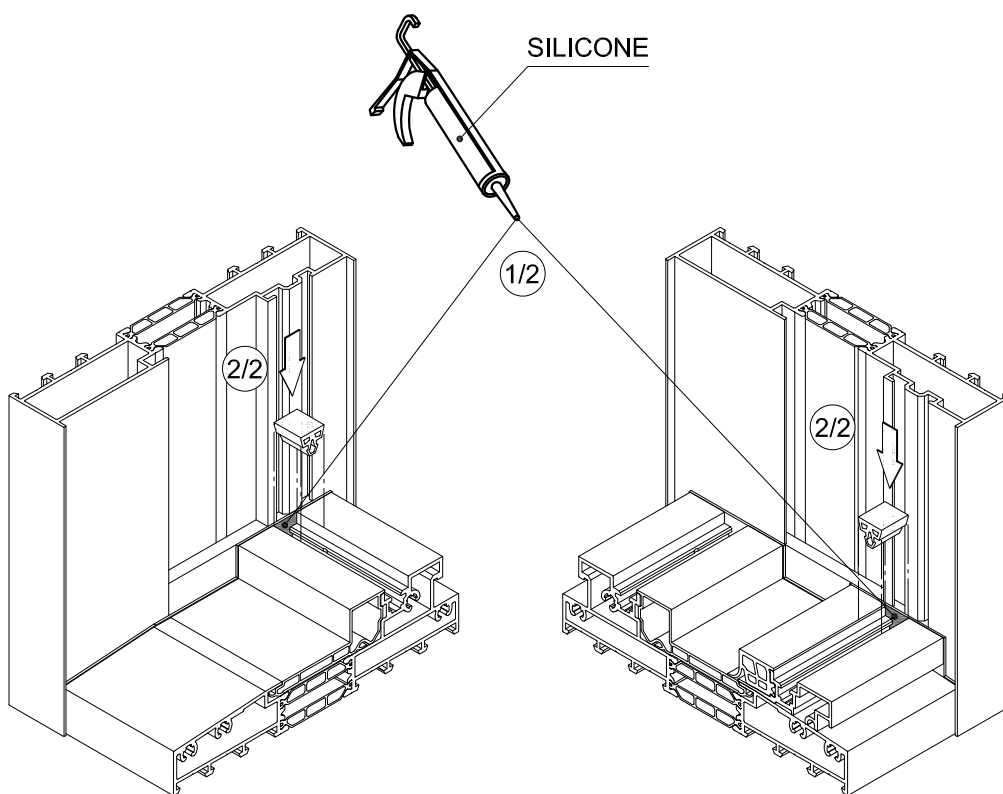
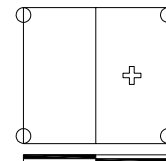

INSTALLAZIONE C9A100 E 213-006 SU ANTA MOBILE LATERALE

2 / 4

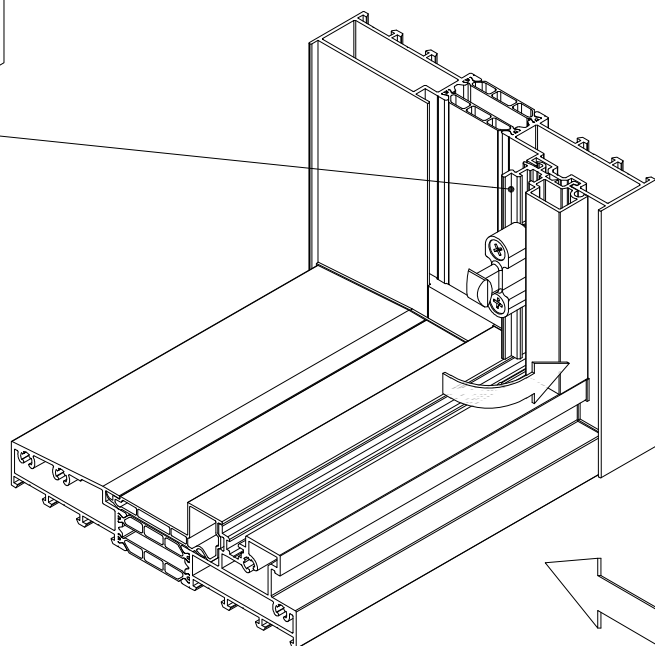
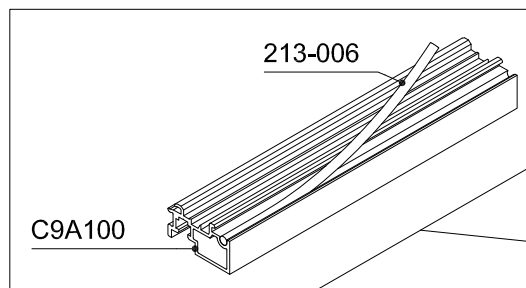
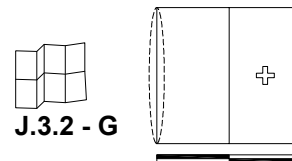

VISTA INTERNA

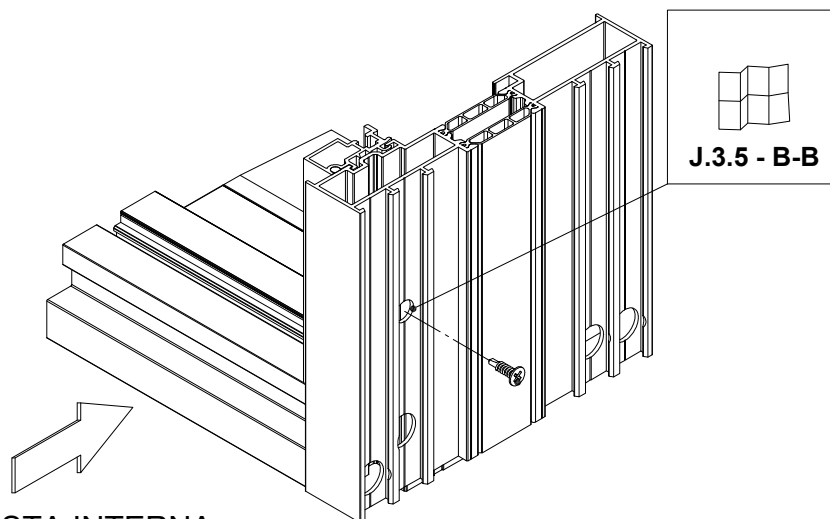
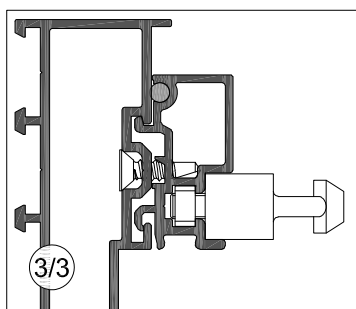
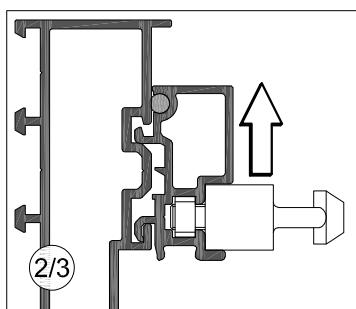
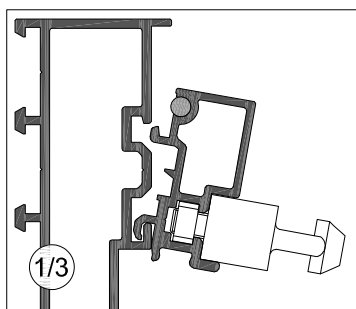

VISTA INTERNA



1-BINARIO TELAIO SOGLIA RIBASSATA TAGLIO 90°

INSTALLAZIONE C9A100 E 213-006 SU ANTA FISSA LATERALE

3 / 4



J.3.2 - G

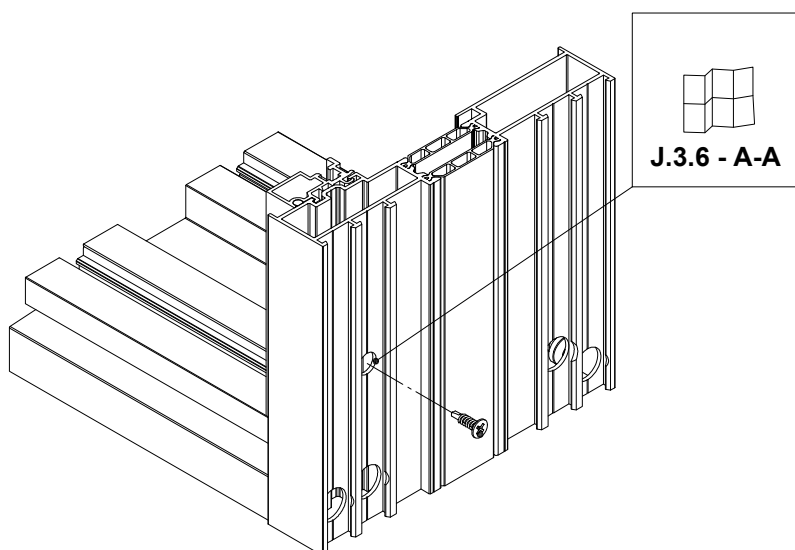
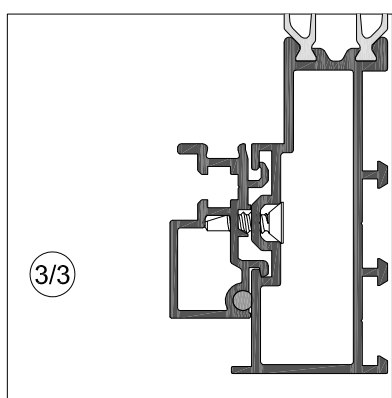
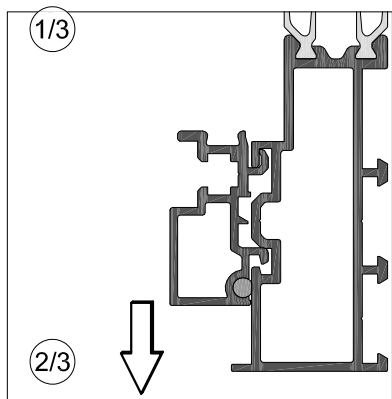
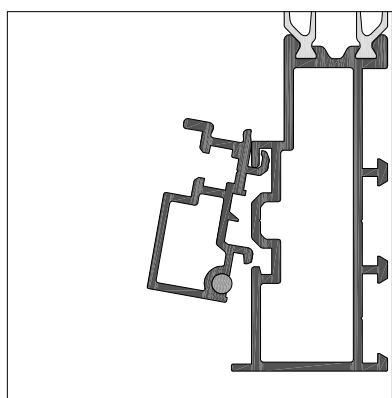
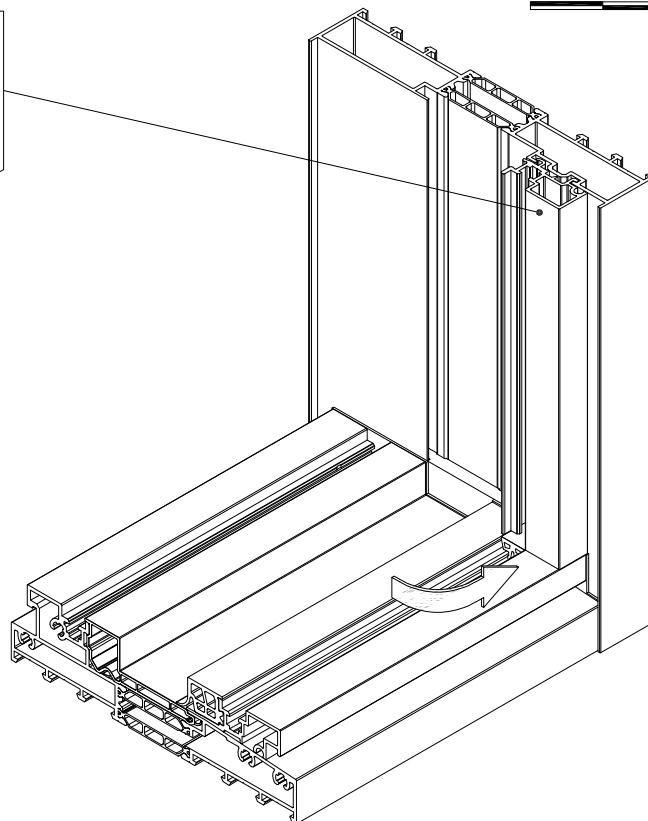
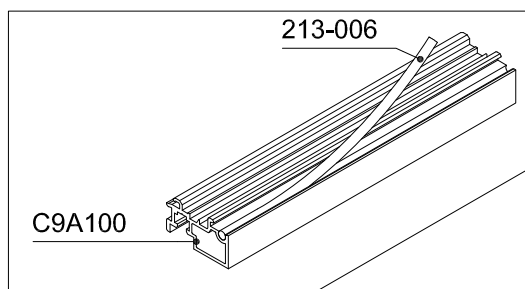
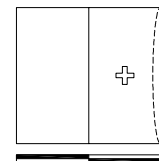

C160-ASS-1535

INSTALLAZIONE KU2035 SUI LATI

4 / 4

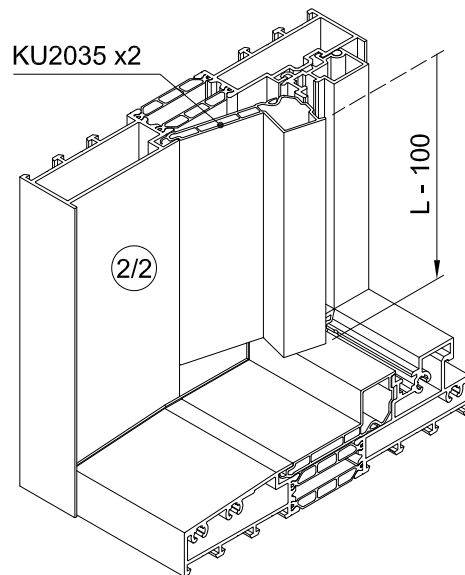
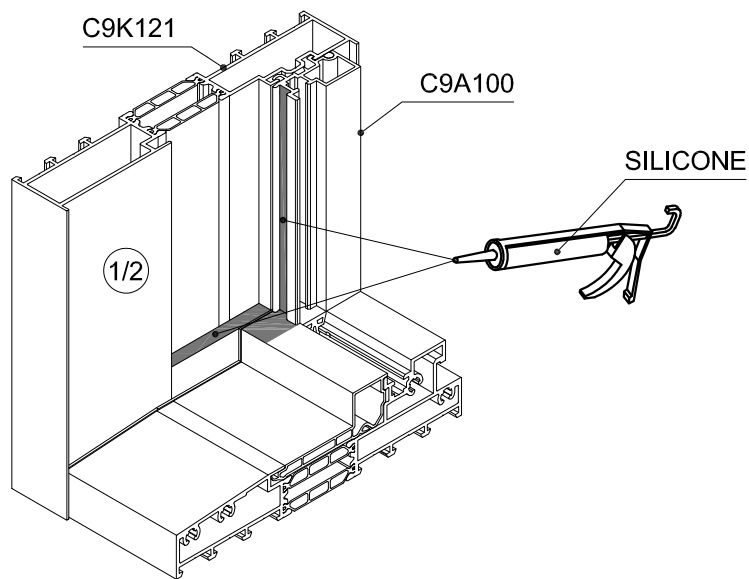
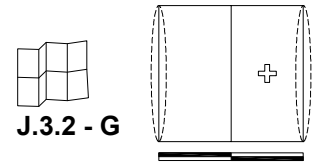



1-BINARIO TELAIIO SOGLIA RIBASSATA TAGLIO 90°

INSTALLAZIONE BINARIO CO1103

1 / 2

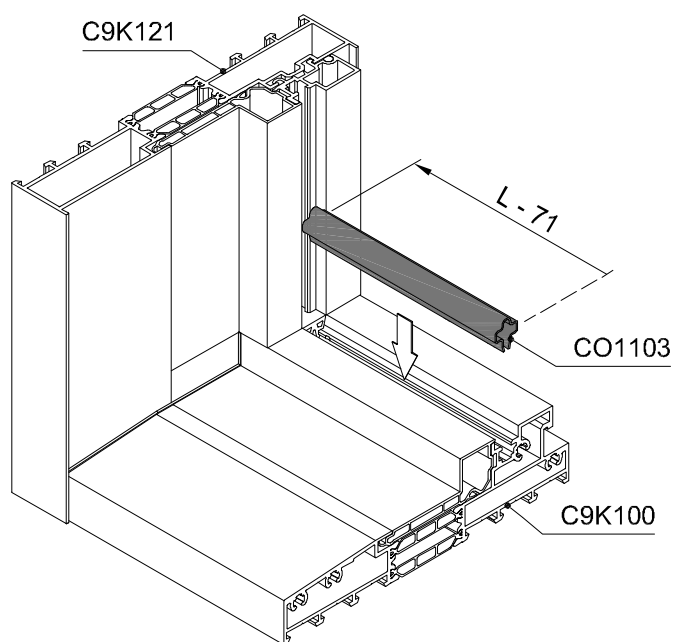
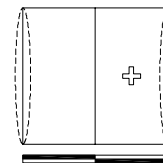

INSTALLAZIONE BINARIO CO1103 E ZB0038 PER SCHEMA 4 ANTE

2 / 2

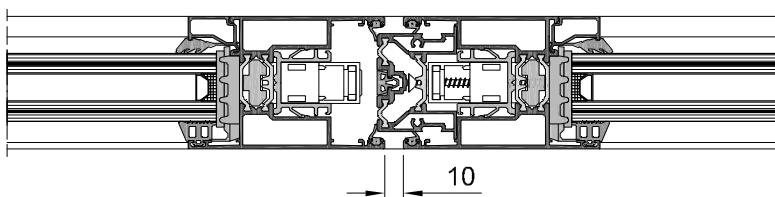
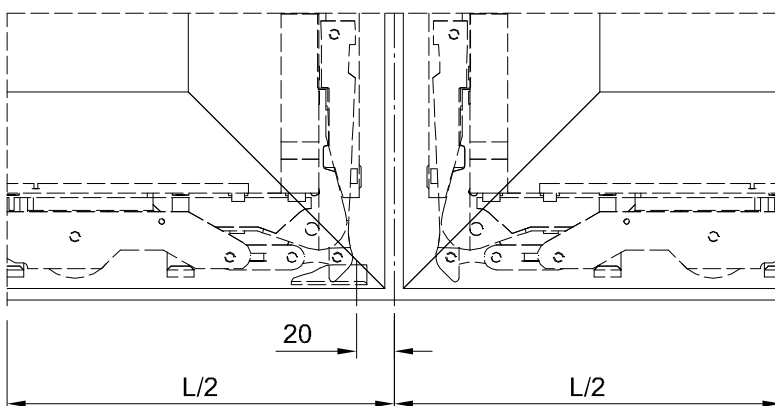
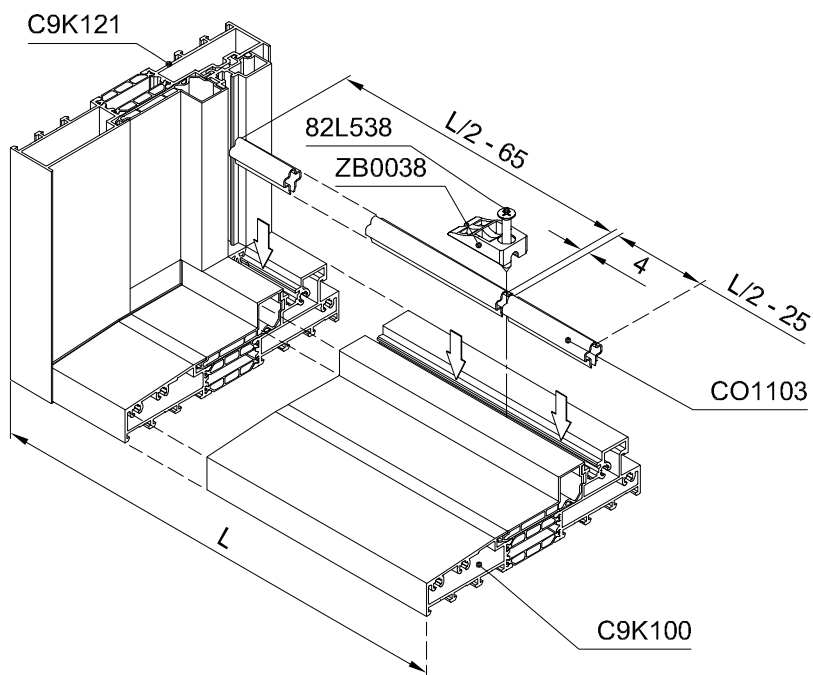
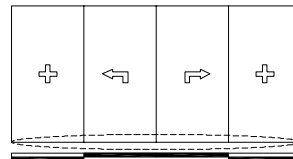



1-BINARIO TELAI SOGLIA RIBASSATA TAGLIO 90°

POSIZIONAMENTO PUNTI DI CHIUSURA

1 / 2

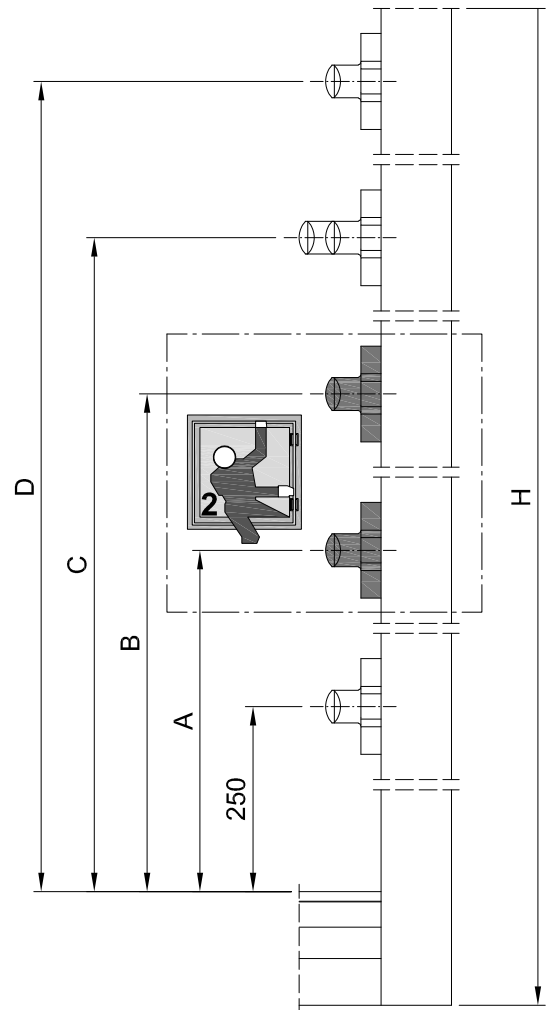
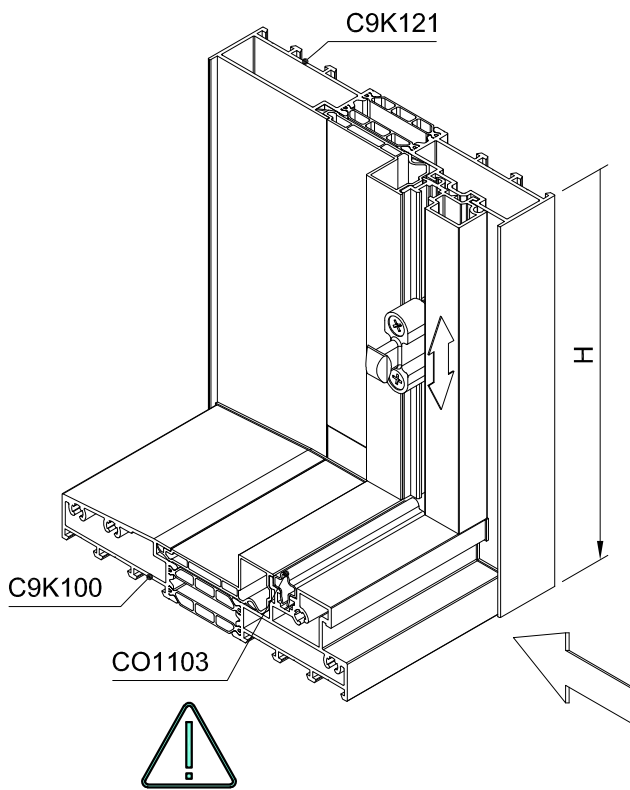
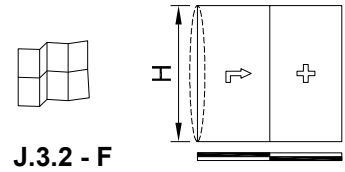

	Hv		ZB0033					Hv
				A	B	C	D	
	1180 - 1877	1312 - 2009	ZB0033	-	600	1000	-	
	1878 - 2177	2010 - 2309	ZB0034	750	1200	1600		
	2178 - 2477	2310 - 2609	ZB0035			1900		
	2478 - 2777	2610 - 2909	ZB0036			2200		
	2778 - 3077	2910 - 3209	ZB0035 + ZB0046			1900	Hv - 271	
	3078 - 3377	3210 - 3509	ZB0036 + ZB0046	2200				

Hv = H - 100



FERRAMENTA & DISEGNI ASSEMBLAGGIO

1-BINARIO TELAIO SOGLIA RIBASSATA TAGLIO 90°



PREPARAZIONE ANTE

PANORAMICA ASSEMBLAGGIO

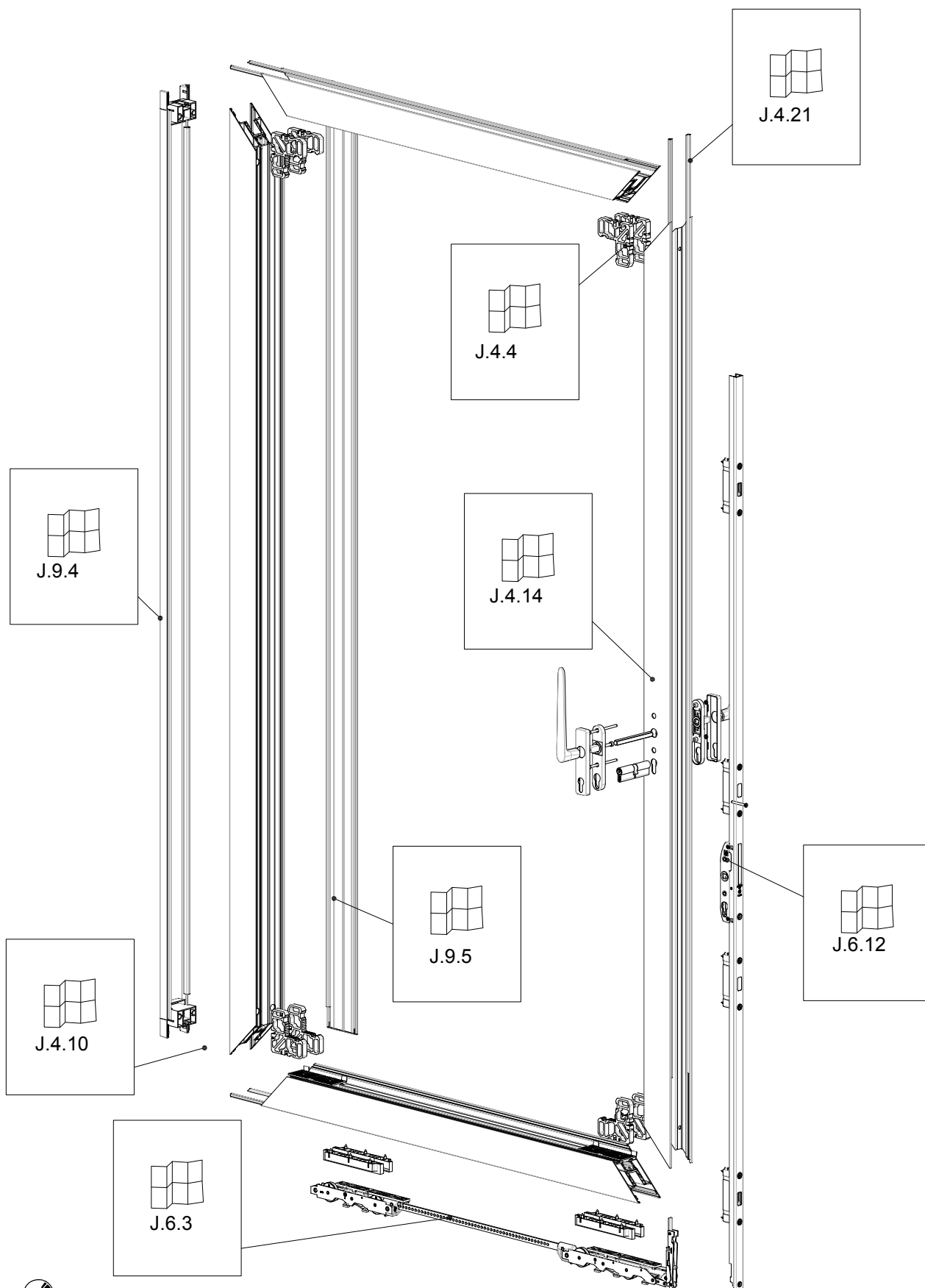

 C160-TYP-511

CONTENUTO

Preparazione ante.....	J.5.1
Panoramica assemblaggio.....	J.5.1
Contenuto.....	J.5.2



Taglio profilati anta e installazione BT6000.....	J.5.3
Lavorazione profilato anta per squadrette.....	J.5.4
Lavorazione del C9V051 profilato anta effetto 'bi-metal'.....	J.5.6



Lavorazione drenaggio profilata anta.....	J.5.7
Panoramica lavorazione paracolpi su profilato anta.....	J.5.8
Lavorazione paracolpi su profilato anta.....	J.5.9
Lavorazione profilato anta per tappo 1/2.....	J.5.10
Lavorazione profilato anta per ferramenta alzante-scorrevole - panoramica.....	J.5.11
Lavorazione profilato anta per ferramenta alzante-scorrevole - panoramica.....	J.5.14
Lavorazione profilato anta per ferramenta alzante-scorrevole - panoramica.....	J.5.15
Lavorazione profilato anta per ferramenta alzante-scorrevole.....	J.5.17



Installazione guarnizione RU0099 per alzante-scorrevole.....	J.5.21
--	--------



Assemblaggio profilato anta con squadrette.....	J.5.23
---	--------



PREPARAZIONE ANTE

TAGLIO PROFILATI ANTA E INSTALLAZIONE BT6000

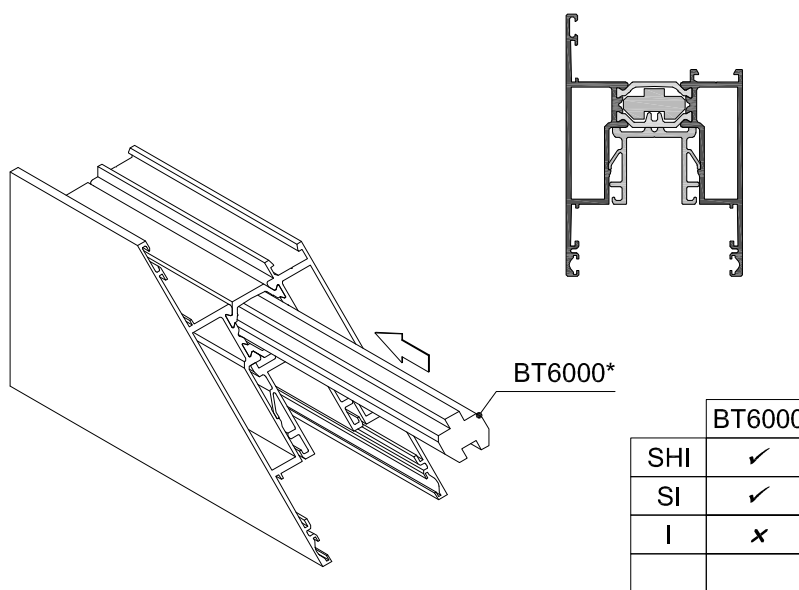
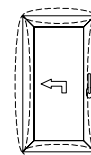
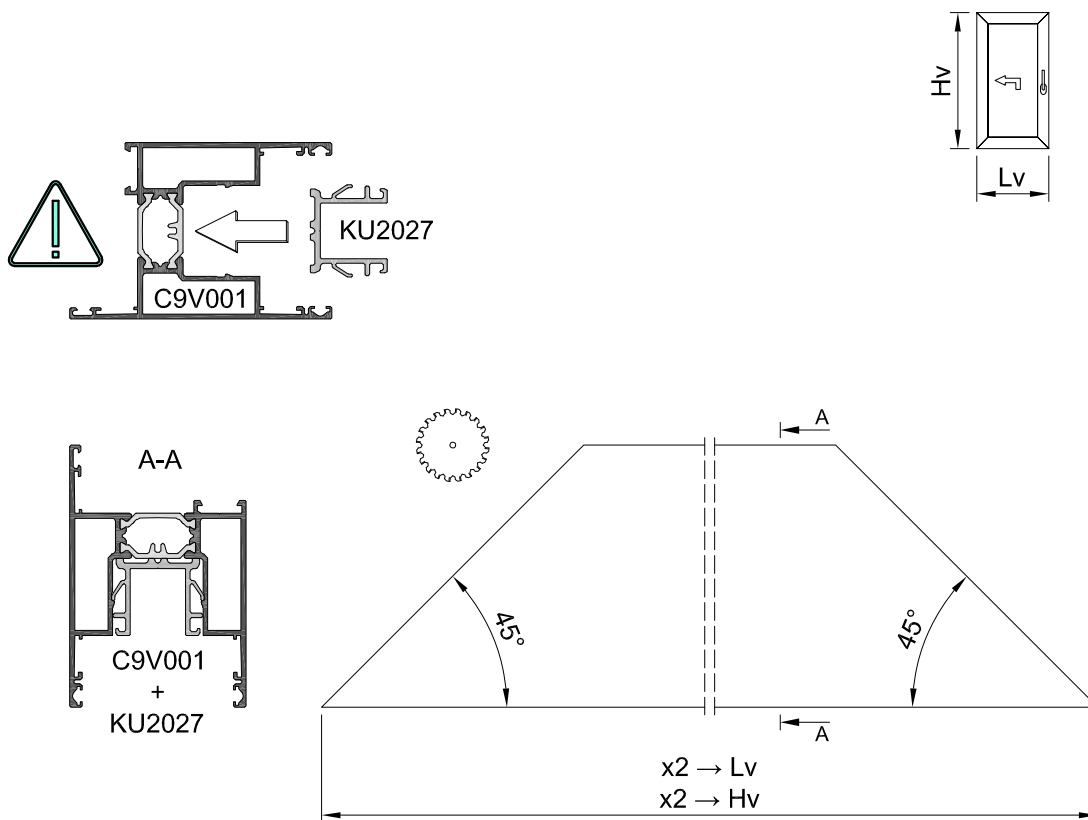

LAVORAZIONE PROFILATO ANTA PER SQUADRETTE

1 / 2

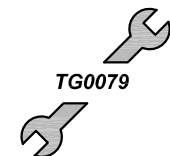
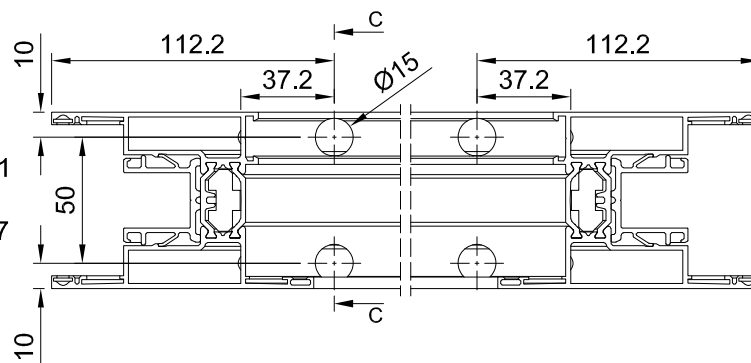
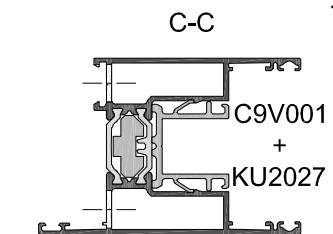
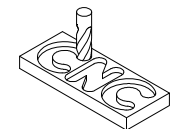
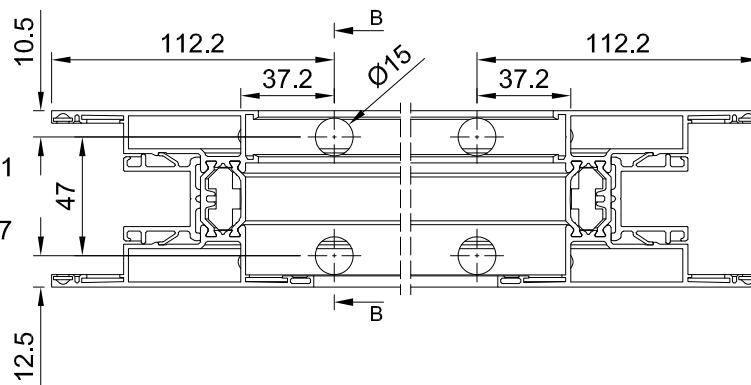
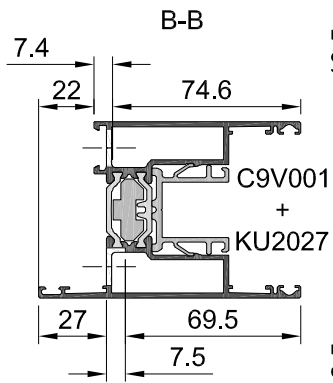
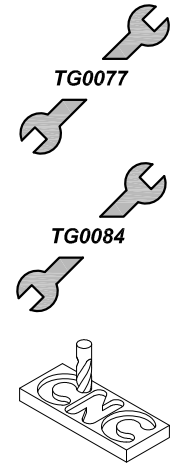
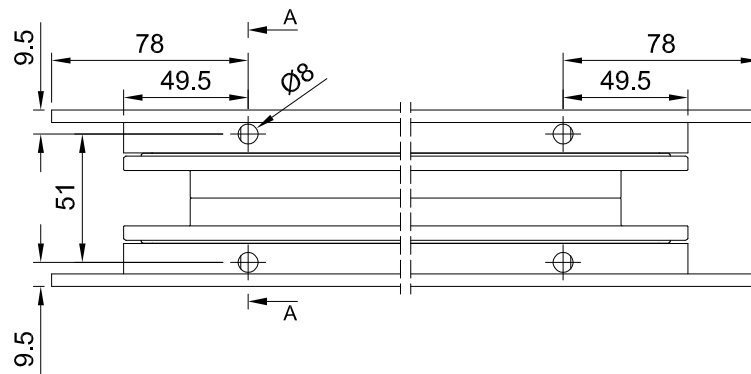
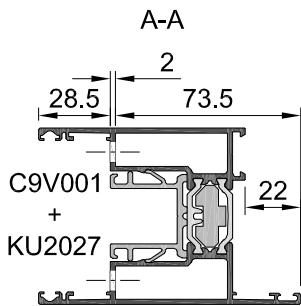
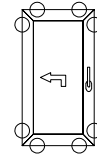
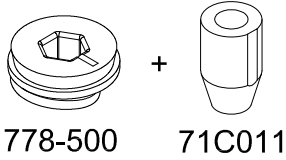



PREPARAZIONE ANTE

LAVORAZIONE PROFILATO ANTA PER SQUADRETTE

2 / 2

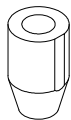

71C011



J.4.23

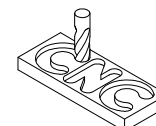
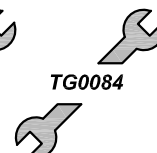
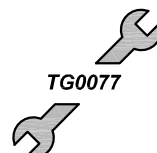
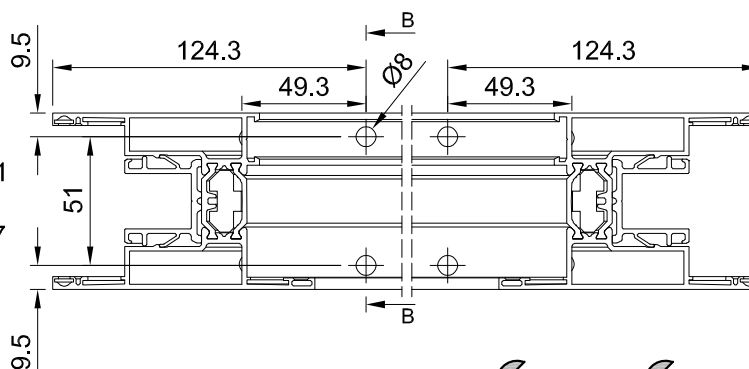
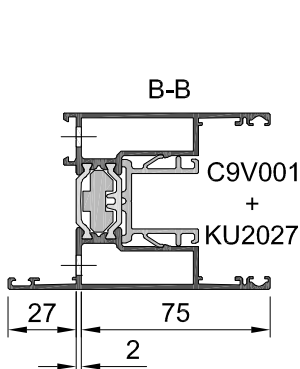
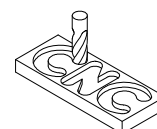
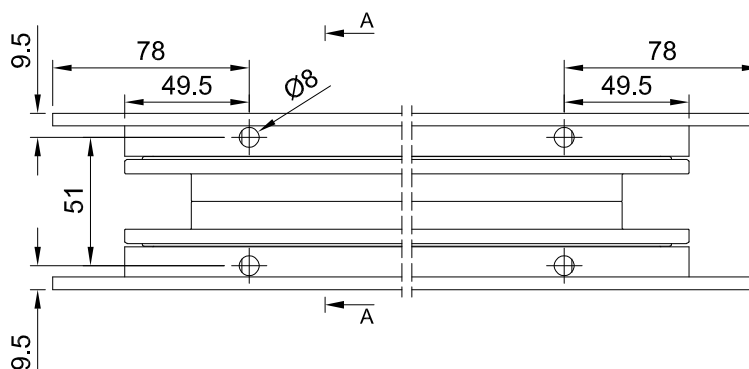
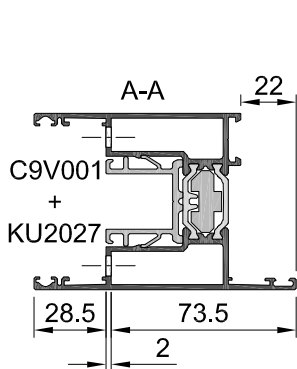
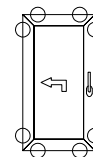

LAVORAZIONE DEL C9V051 PROFILATO ANTA EFFETTO 'BI-METAL'

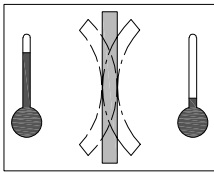

C9V051

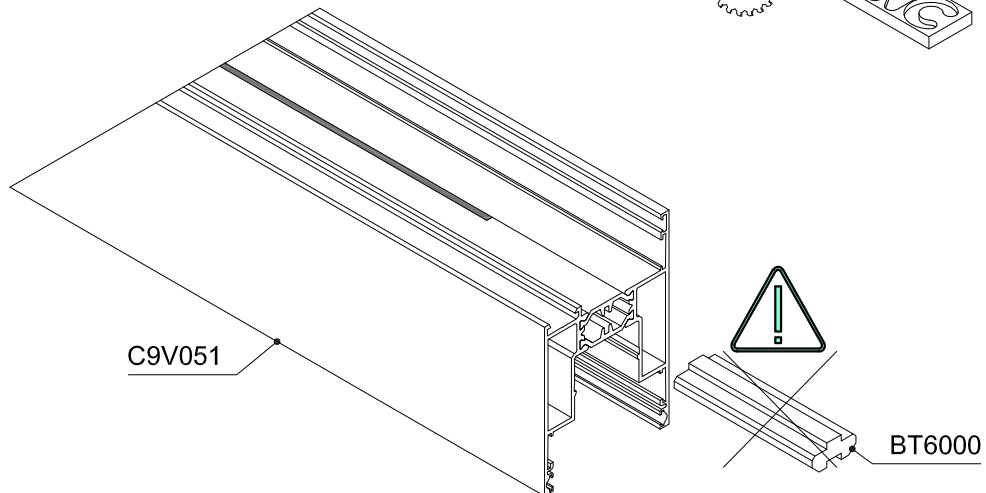
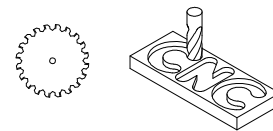
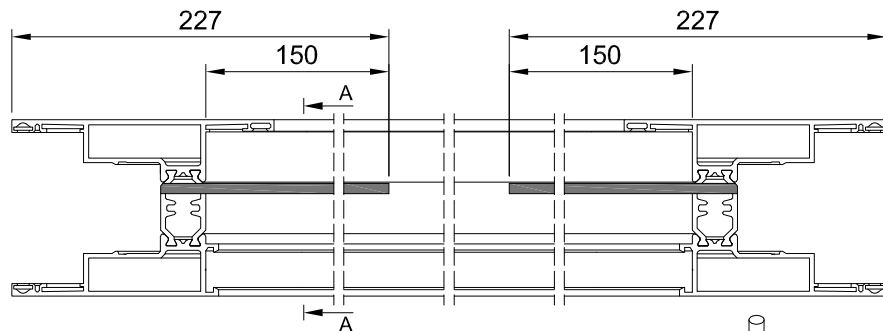
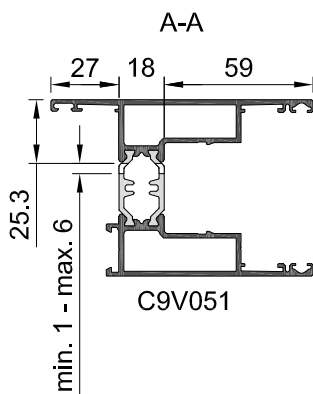
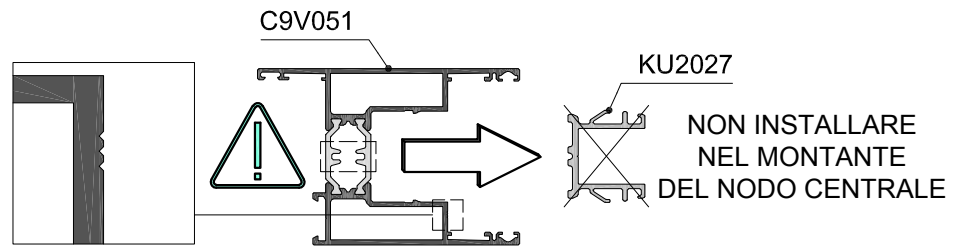
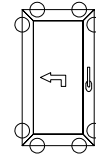

LAVORAZIONE DEL C9V051 PROFILATO ANTA EFFETTO 'BI-METAL'

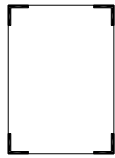
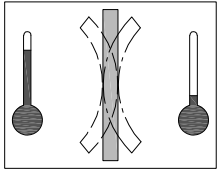

C9V051

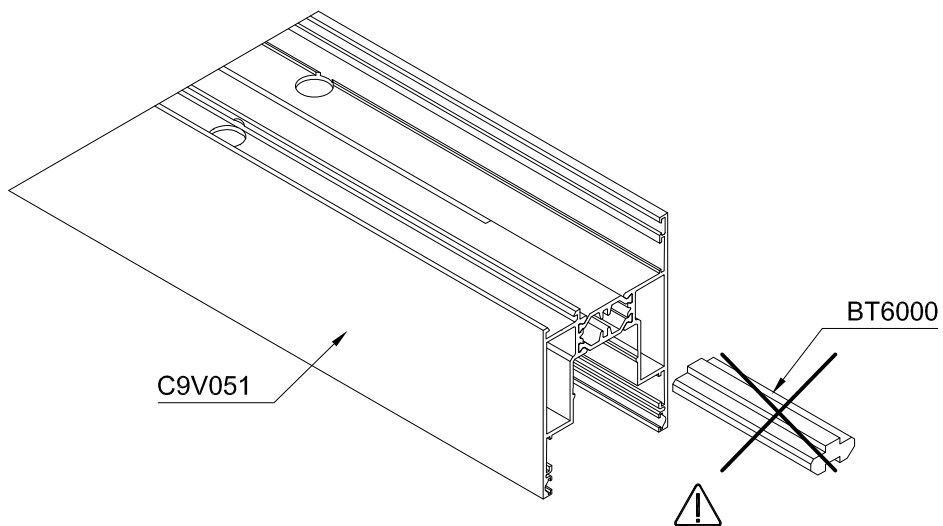
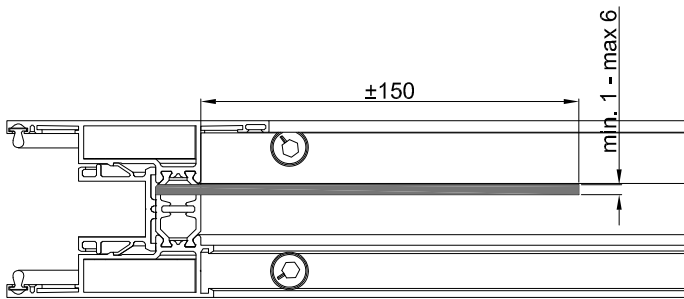
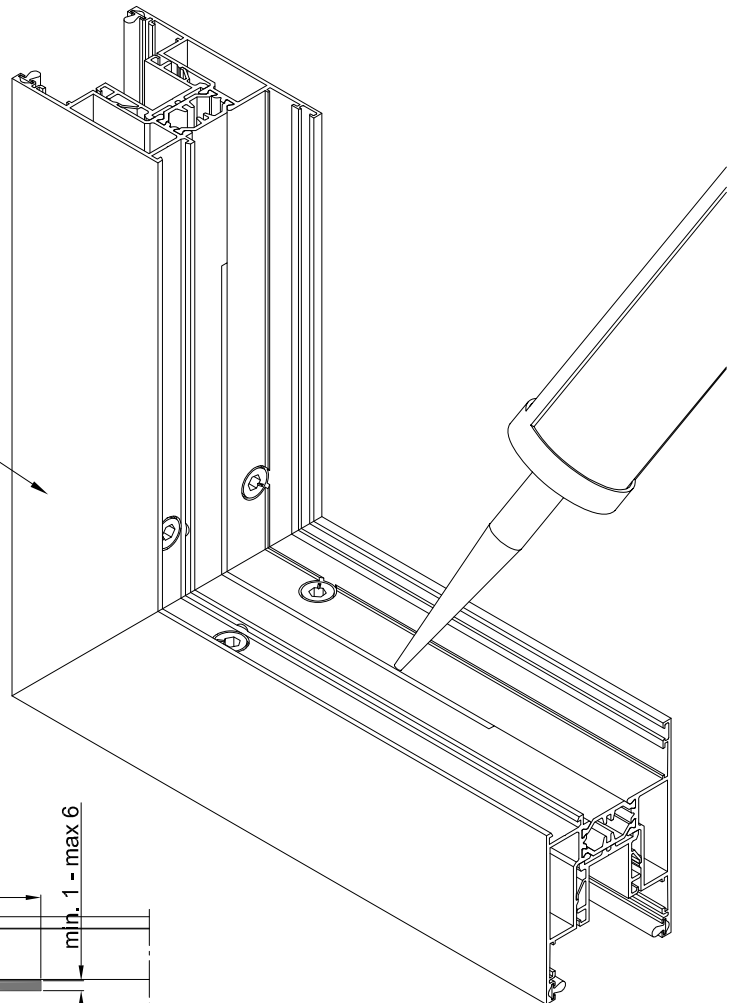

IMPIEGO DEL C9V051 PROFILATO ANTA EFFETTO 'BI-METAL'

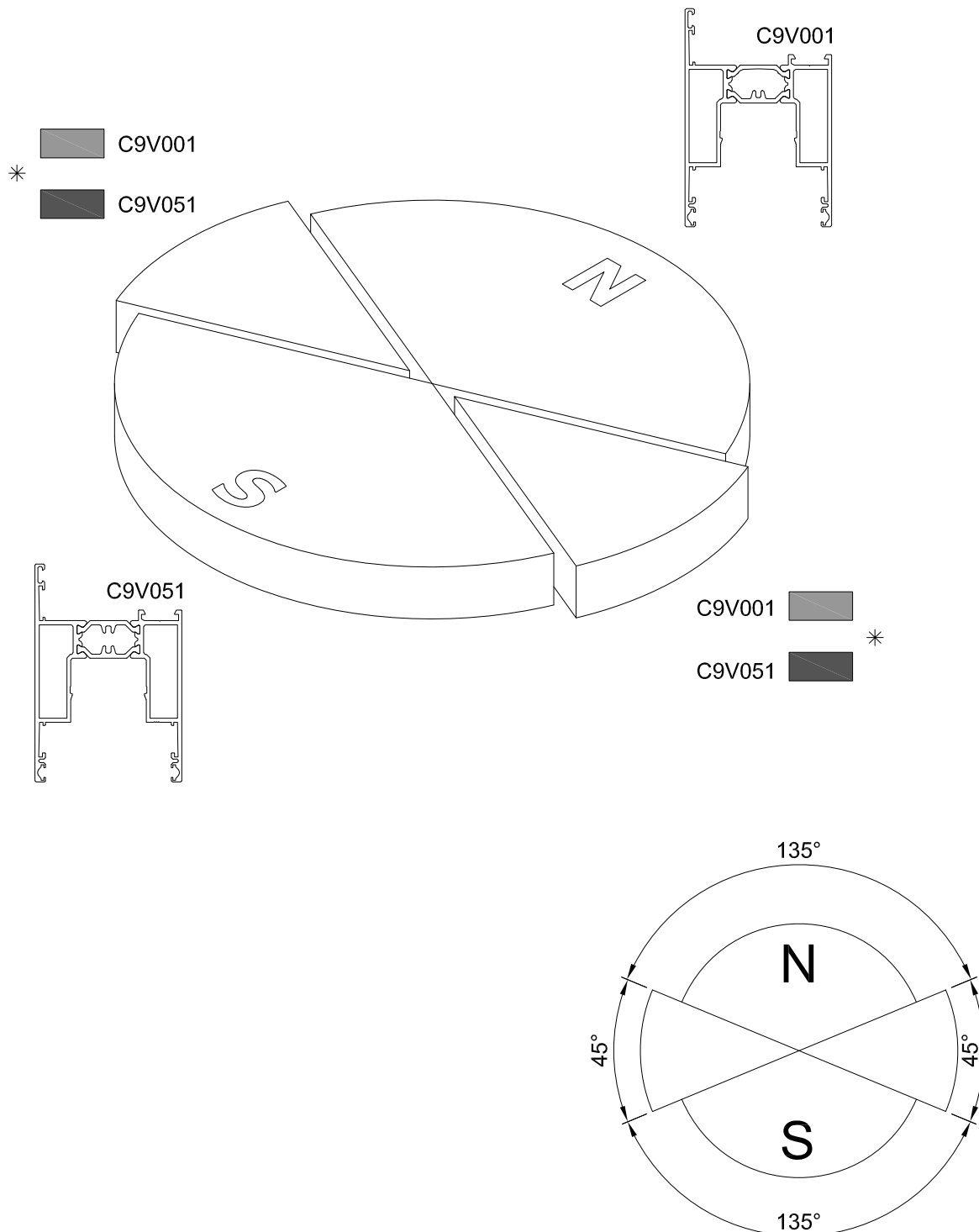

•NOTA:

* C9V001: colori chiari, C9V051: colori scuri
 assemblaggio C9V051: J.4.6, stability C9V051: K.1.2.



PREPARAZIONE ANTE

LAVORAZIONE DRENAGGIO PROFILATA ANTA

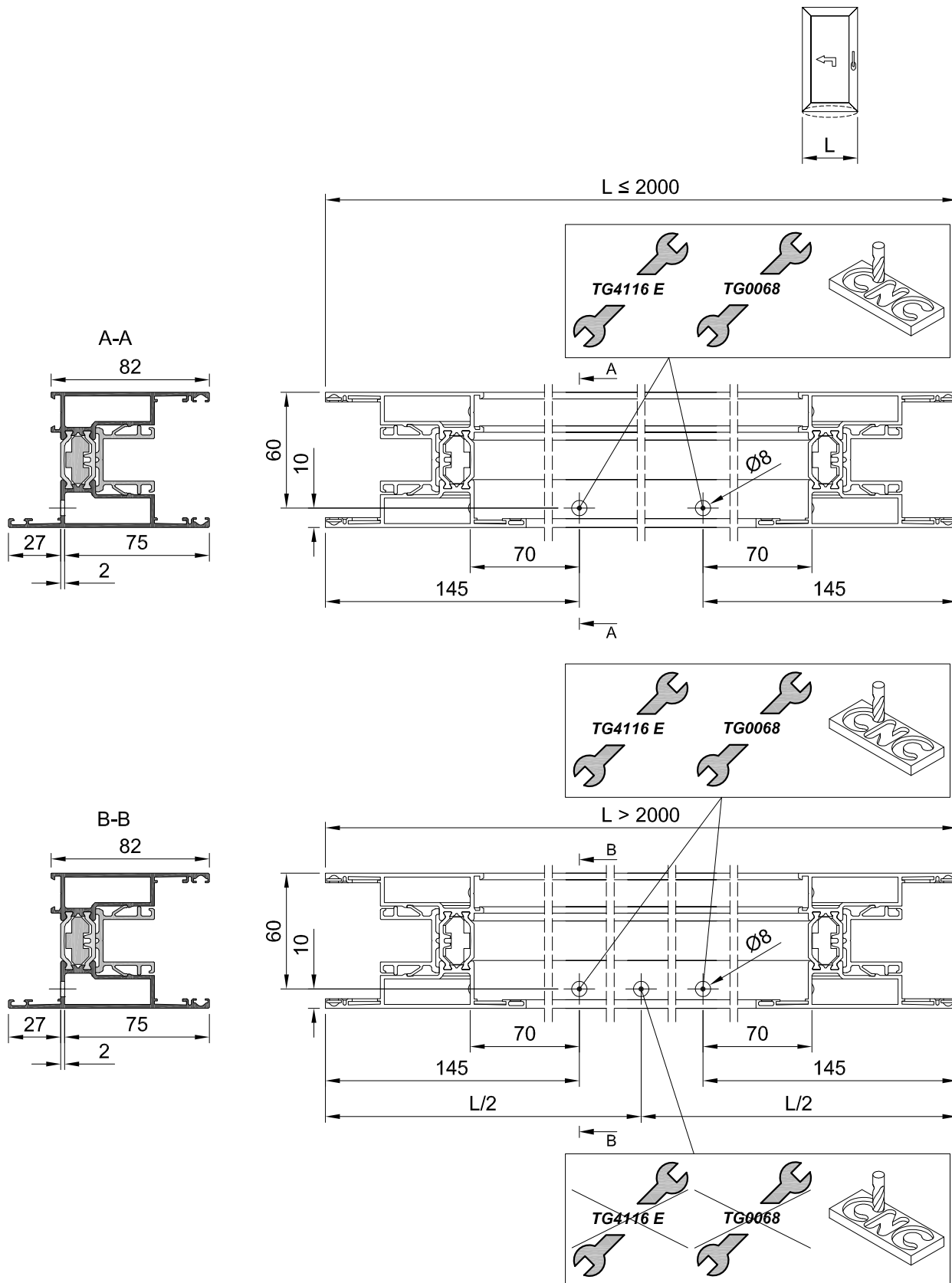

PANORAMICA LAVORAZIONE PARACOLPI SU PROFILATO ANTA

1 / 2

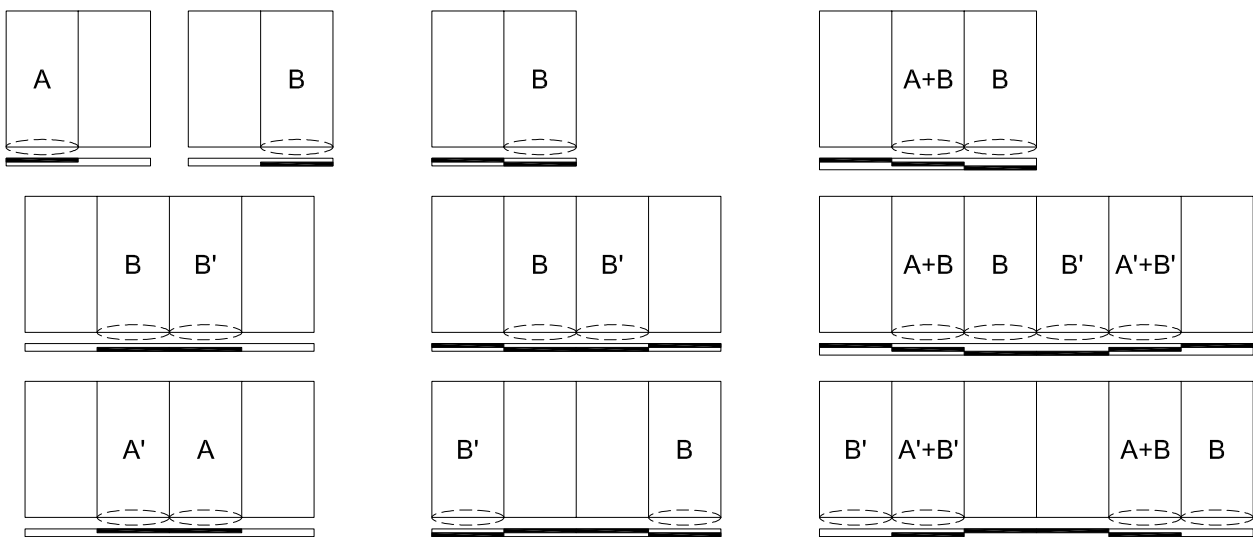
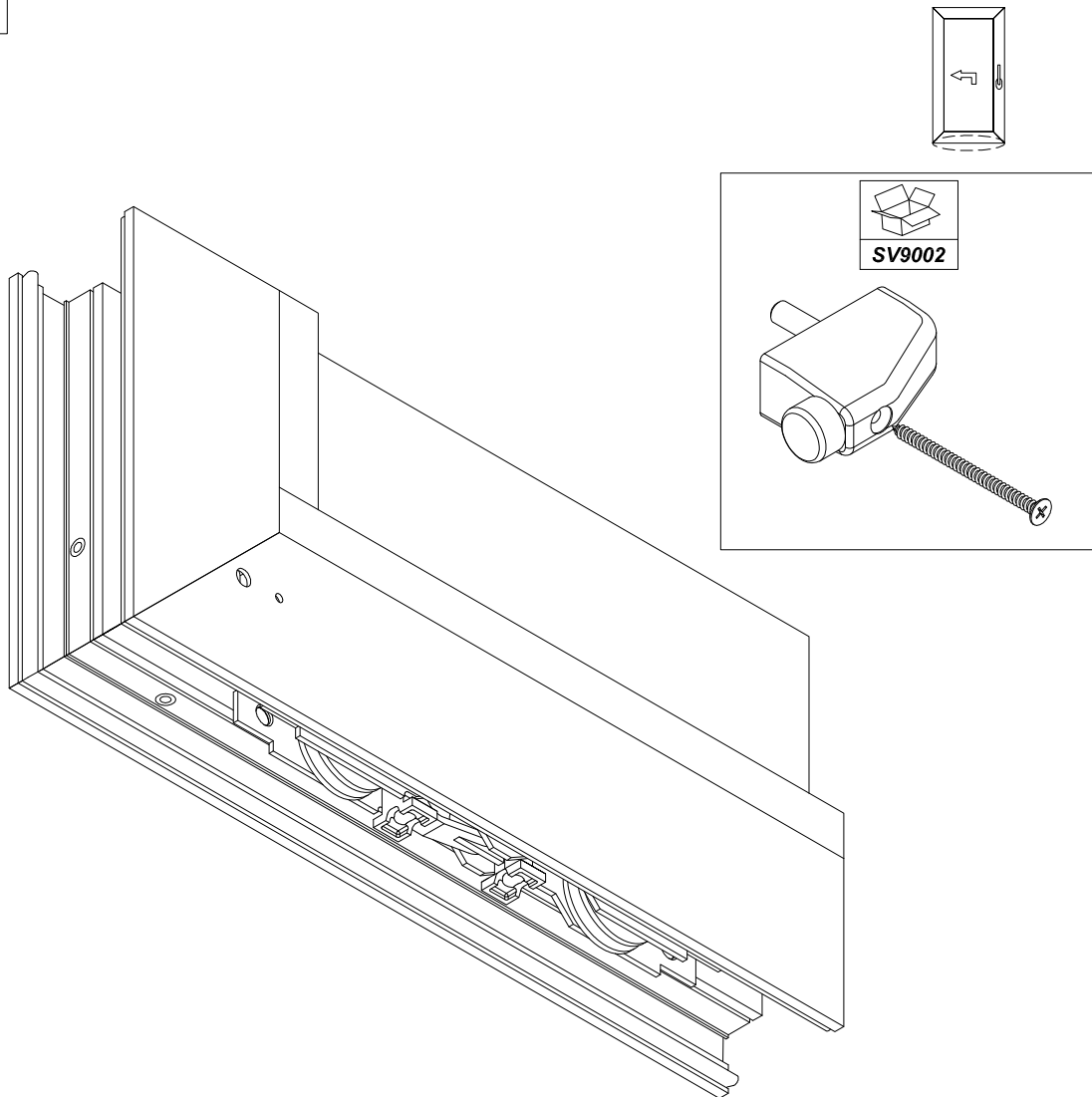



PREPARAZIONE ANTE

LAVORAZIONE PARACOLPI SU PROFILATO ANTA

2 / 2

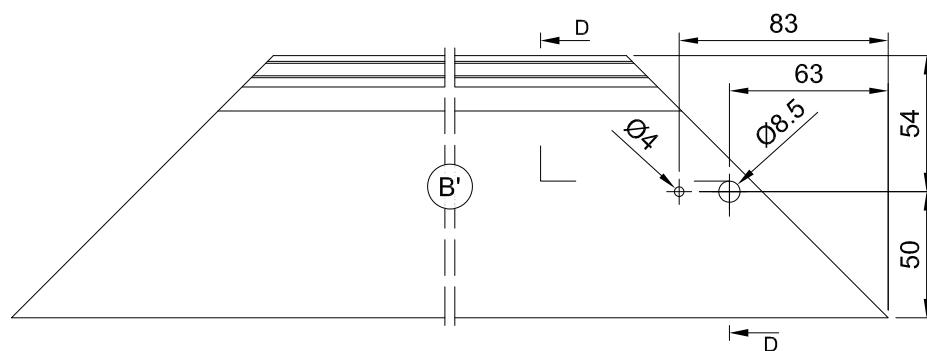
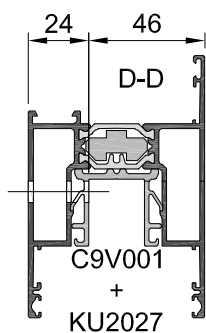
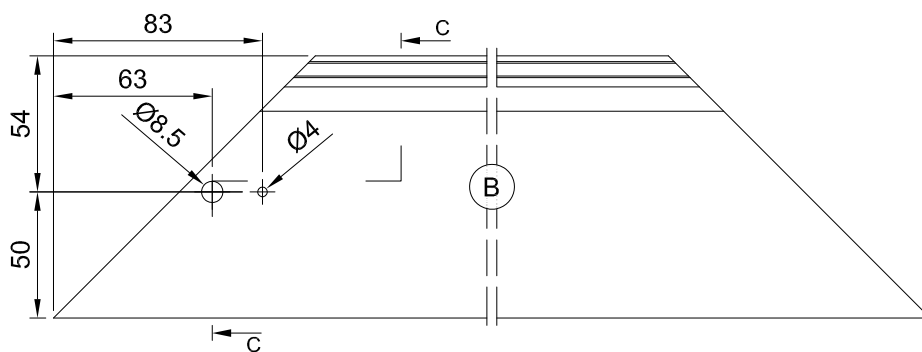
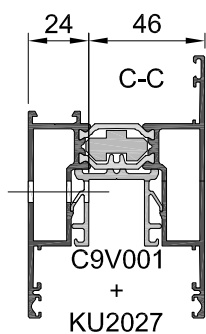
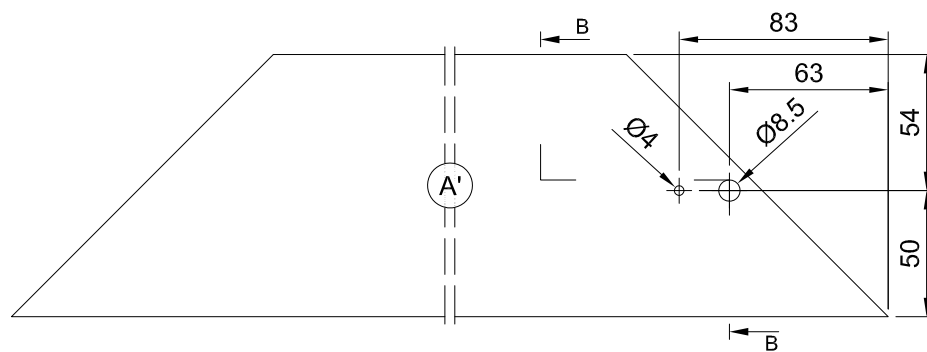
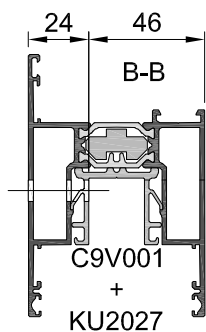
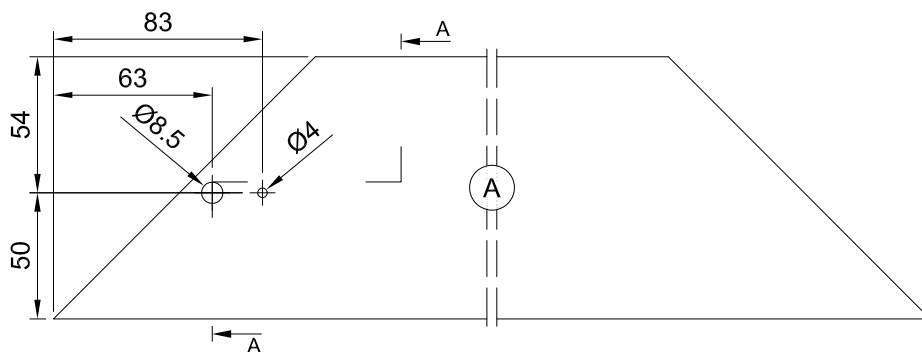
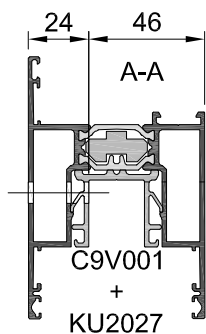
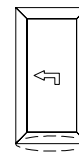

LAVORAZIONE PROFILATO ANTA PER TAPPO 1/2

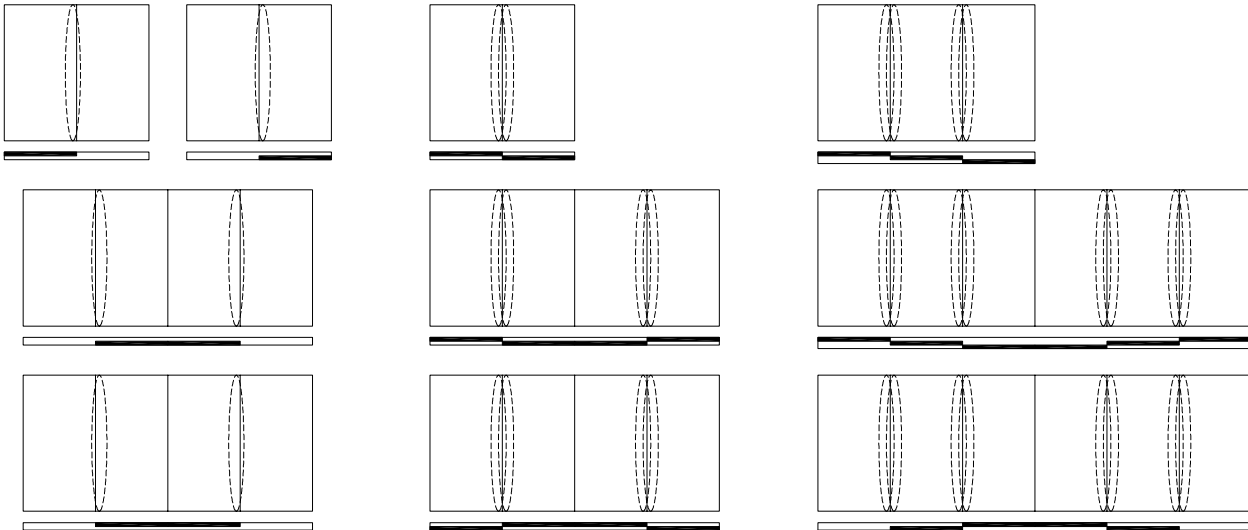
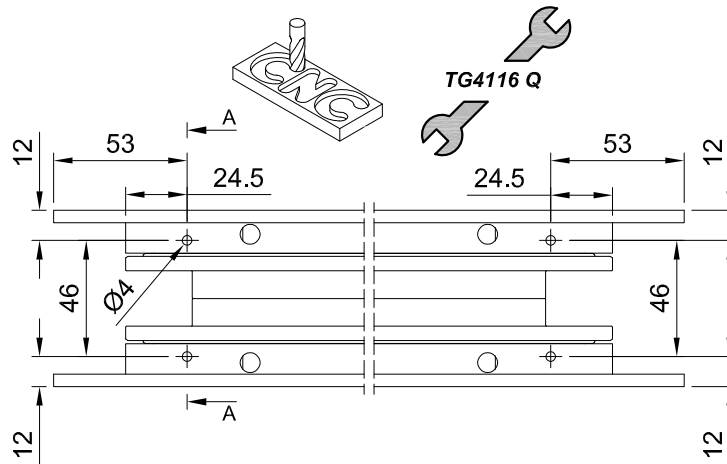
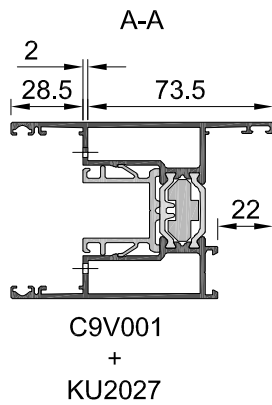
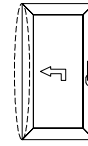



PREPARAZIONE ANTE

LAVORAZIONE PROFILATO ANTA PER FERRAMENTA ALZANTE-SCORREVOLE - PANORAMICA

1 / 5

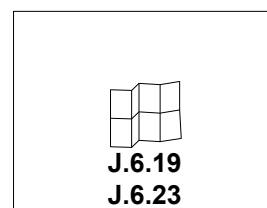
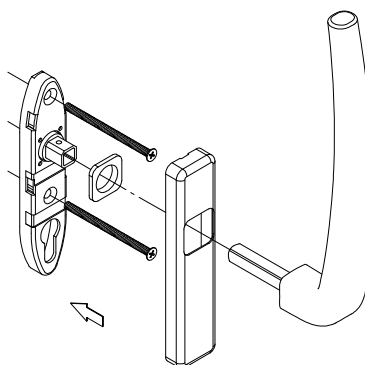
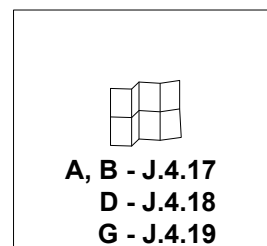
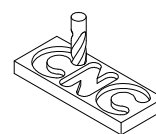
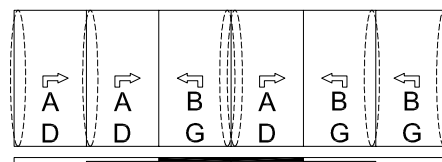
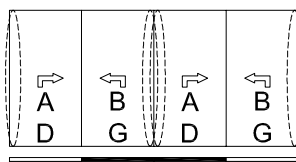
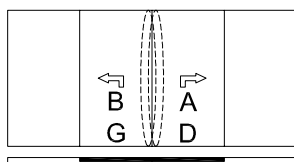
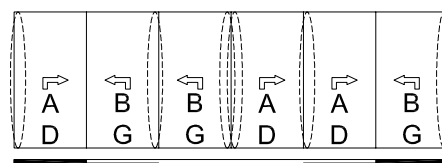
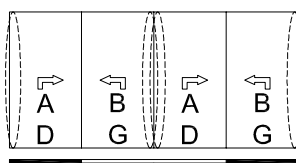
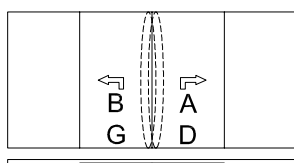
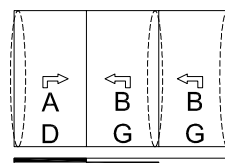
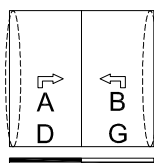
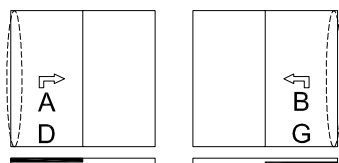
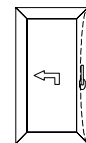

LAVORAZIONE PROFILATO ANTA PER FERRAMENTA ALZANTE-SCORREVOLE - PANORAMICA

2 / 5

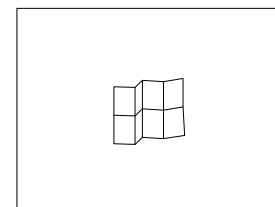
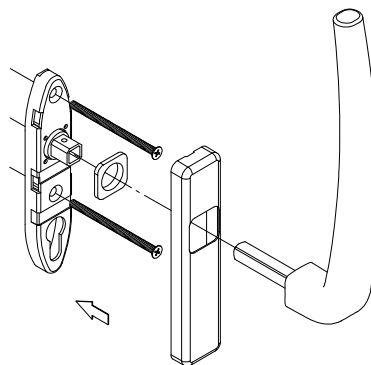
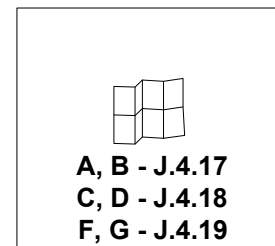
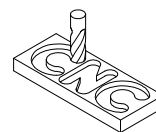
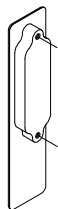
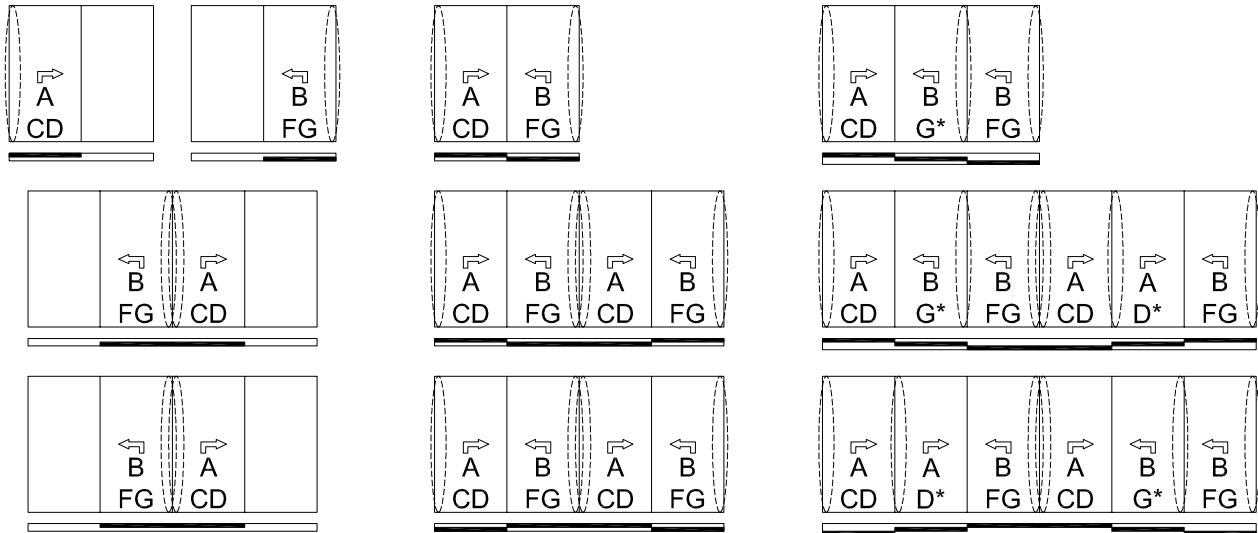
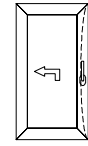

J.6.19 J.6.24

* - S-LINE



PREPARAZIONE ANTE

LAVORAZIONE PROFILATO ANTA PER FERRAMENTA ALZANTE-SCORREVOLE - PANORAMICA

3 / 5

C9V001+KU2027
C9V051+KU2027
C9V004

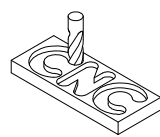
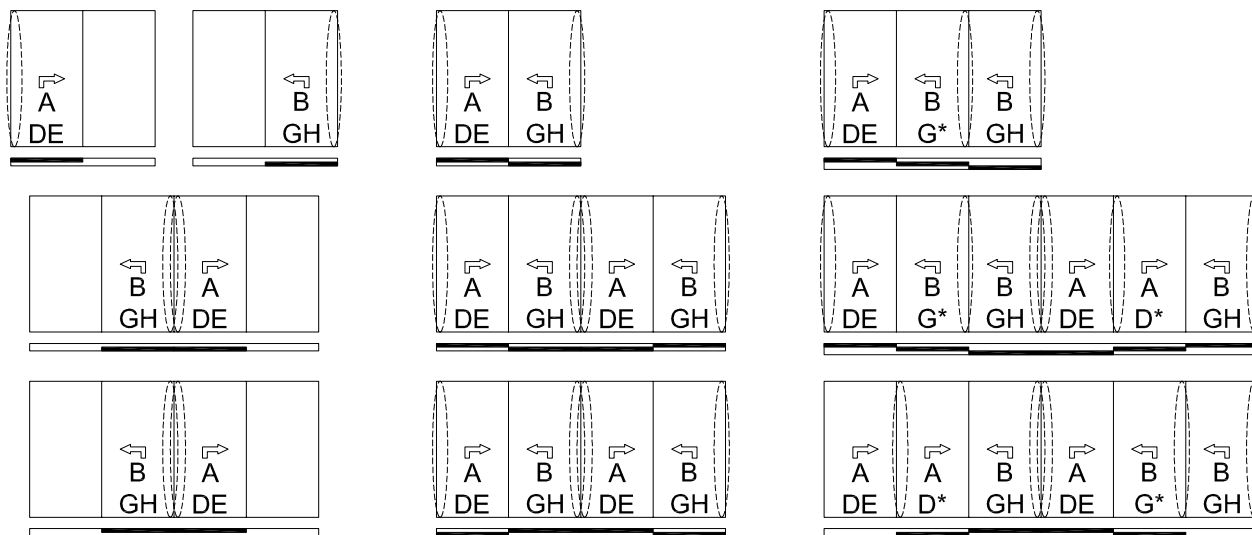
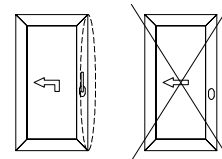

A, B - J.4.17 C, D - J.4.18 F, G - J.4.19

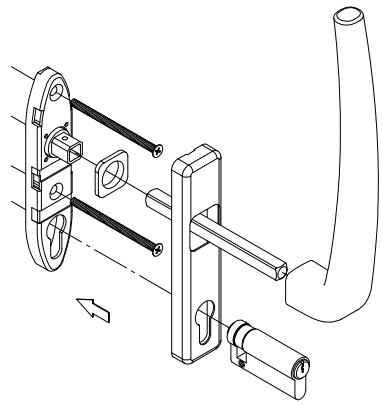

J.6.20 J.6.25 *J.6.19 *J.6.23

* - S-LINE

LAVORAZIONE PROFILATO ANTA PER FERRAMENTA ALZANTE-SCORREVOLE - PANORAMICA

3 / 5

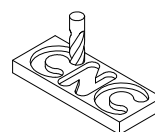
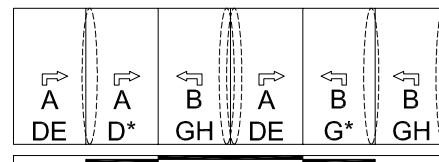
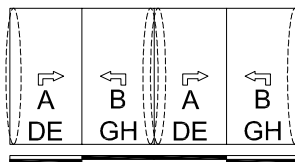
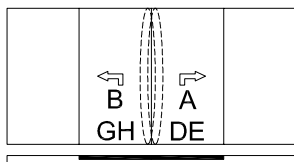
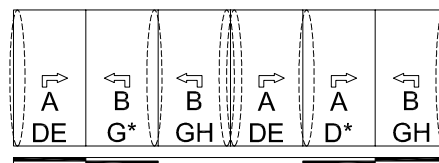
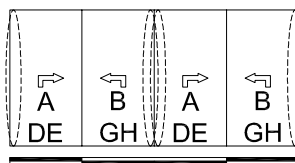
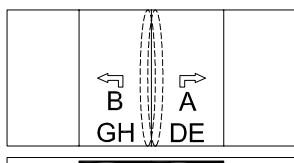
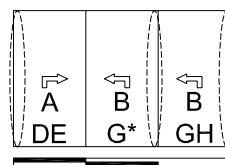
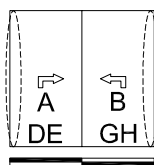
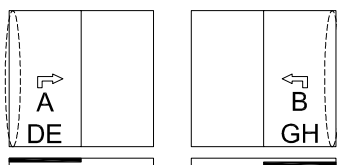
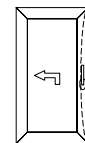

A, B - J.4.17
C, D, E - J.4.18
F, G, H - J.4.19

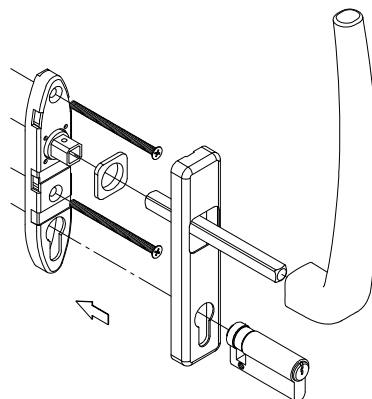

J.6.21 J.6.26
*J.6.19 *J.6.26

* - S-LINE



PREPARAZIONE ANTE

LAVORAZIONE PROFILATO ANTA PER FERRAMENTA ALZANTE-SCORREVOLE - PANORAMICA

4 / 5

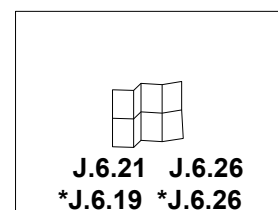
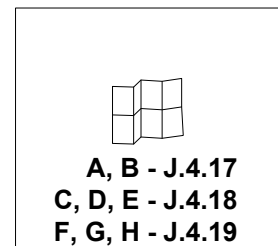
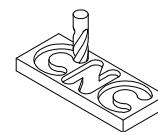
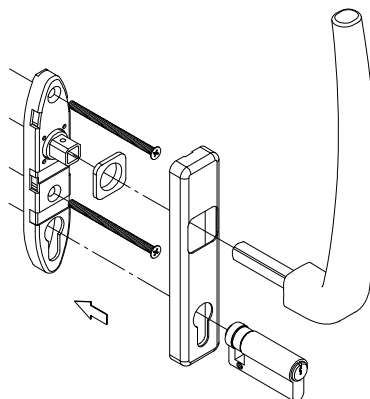
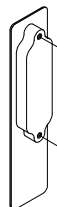
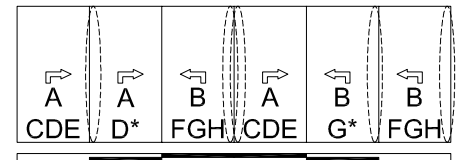
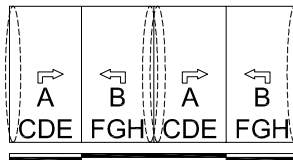
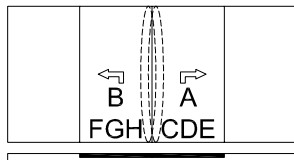
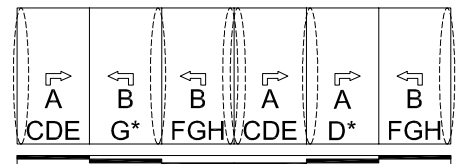
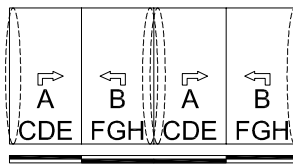
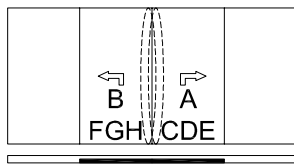
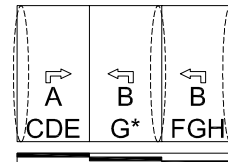
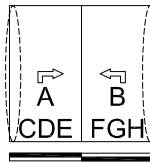
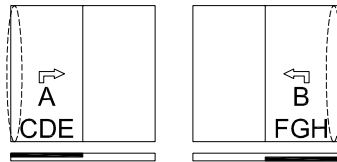
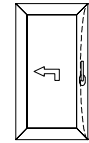



* - S-LINE

LAVORAZIONE PROFILATO ANTA PER FERRAMENTA ALZANTE-SCORREVOLE - PANORAMICA

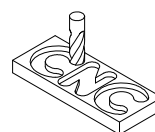
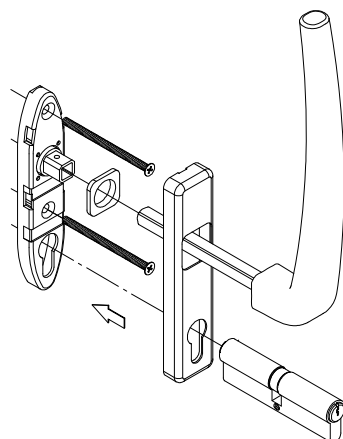
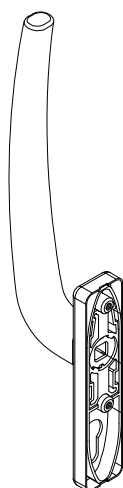
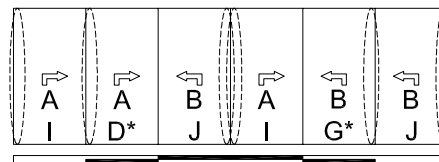
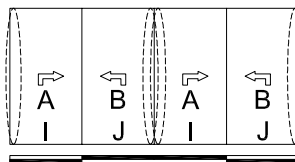
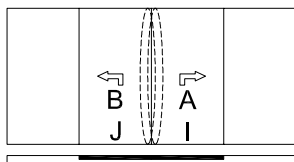
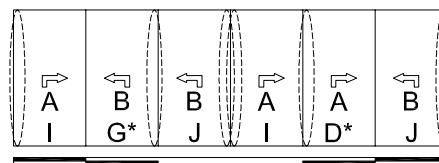
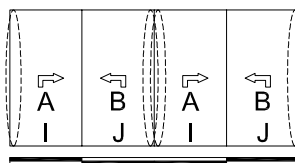
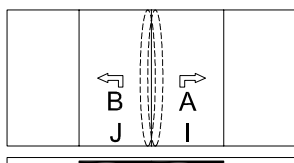
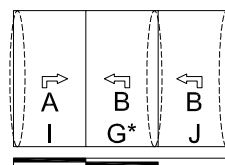
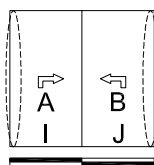
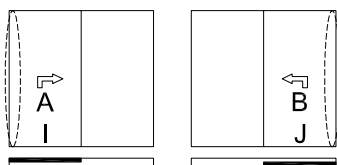
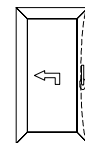
5 / 5



A, B - J.4.17
I, J - J.4.20
D - J.4.18
G - J.4.19

J.6.22 J.6.27
***J.6.19 *J.6.23**

* - S-LINE



PREPARAZIONE ANTE

LAVORAZIONE PROFILATO ANTA PER FERRAMENTA ALZANTE-SCORREVOLE

1 / 4

Hh	Hv	
1003	1904 - 3403	
403	1303 - 1903	

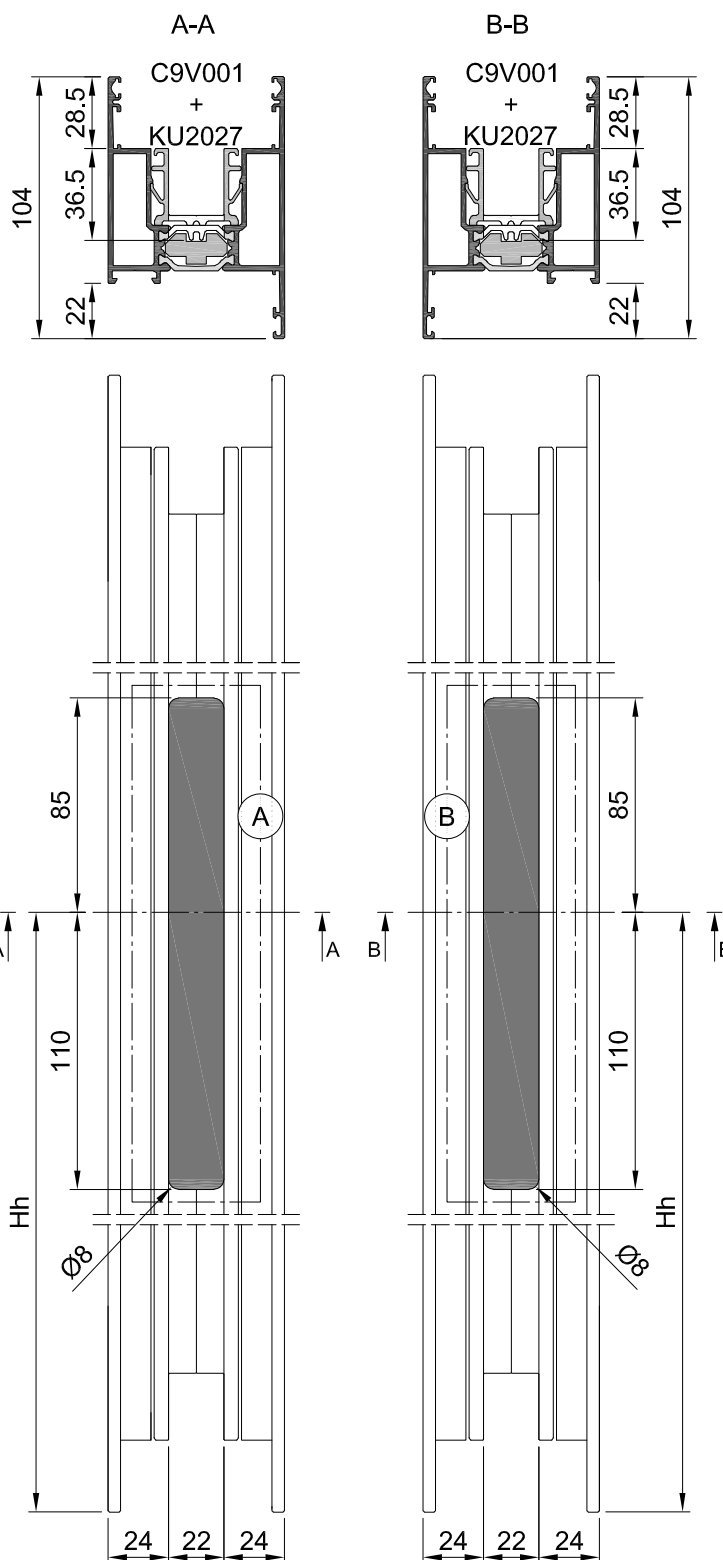
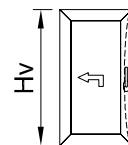

C160-ASS-2123L

LAVORAZIONE PROFILATO ANTA PER FERRAMENTA ALZANTE-SCORREVOLE

2 / 4

Hh	Hv	
1003	1904 - 3403	
403	1303 - 1903	

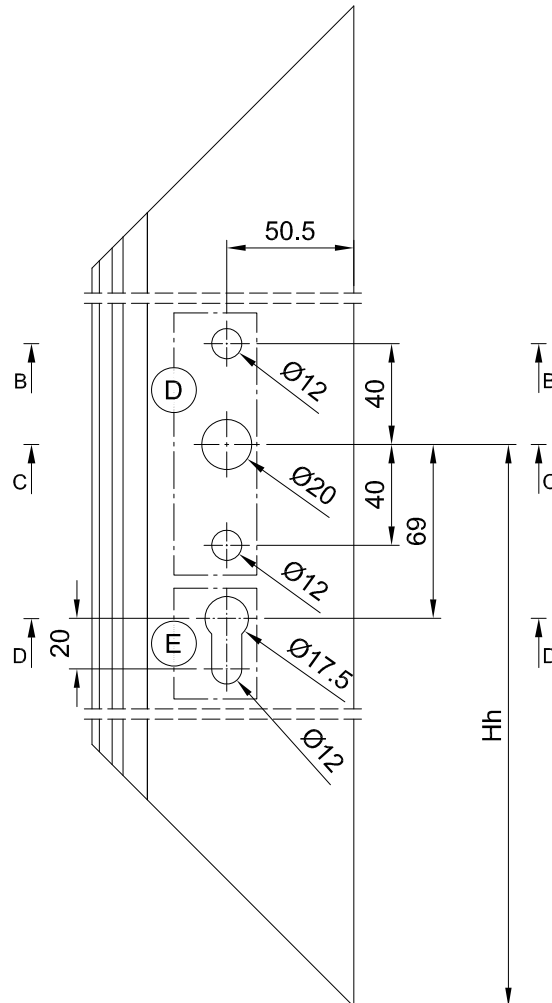
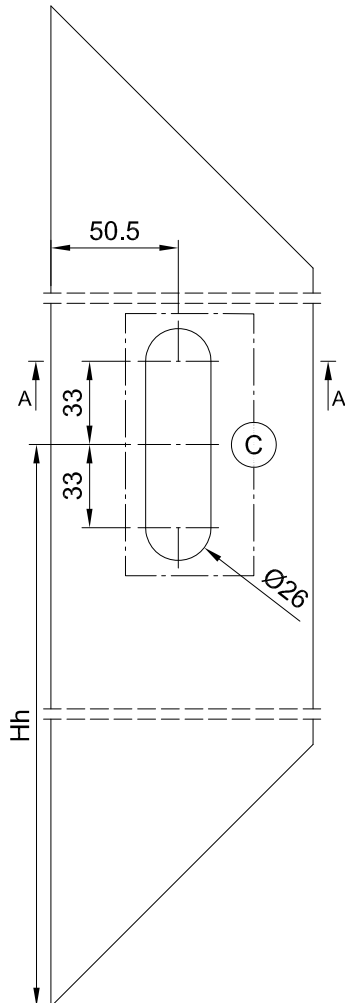
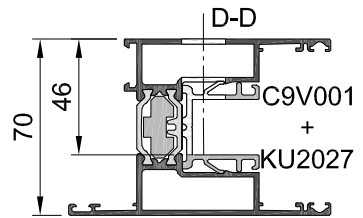
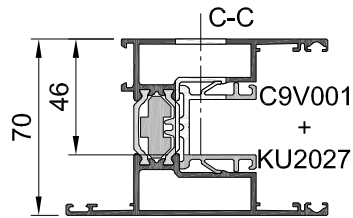
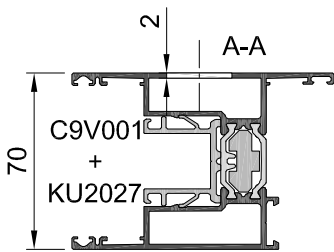
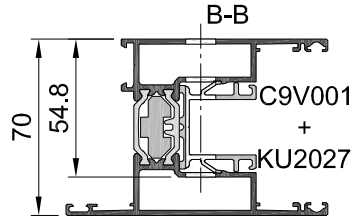
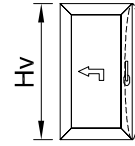



PREPARAZIONE ANTE

LAVORAZIONE PROFILATO ANTA PER FERRAMENTA ALZANTE-SCORREVOLE

3 / 4

Hh	Hv	
1003	1904 - 3403	
403	1303 - 1903	

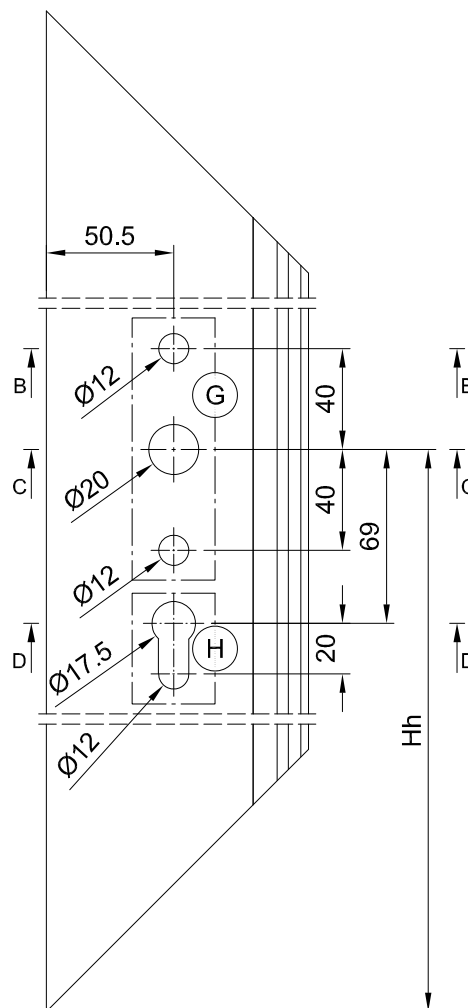
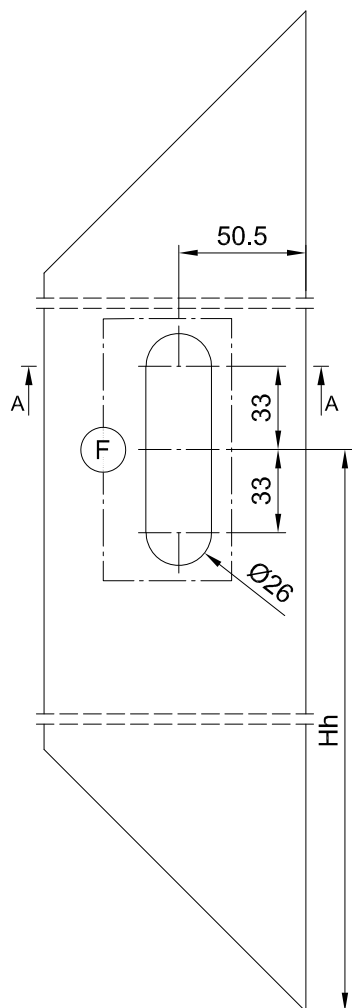
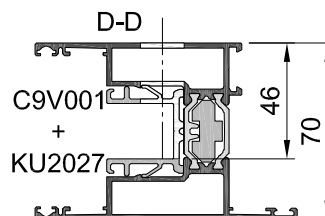
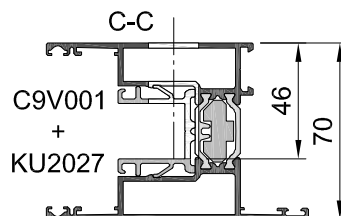
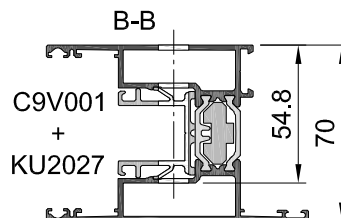
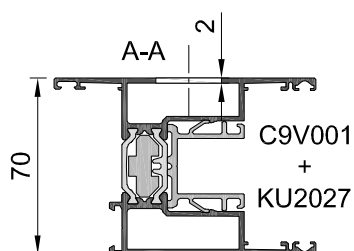
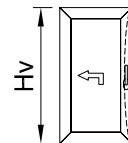

C160-ASS-2125L

LAVORAZIONE PROFILATO ANTA PER FERRAMENTA ALZANTE-SCORREVOLE

4 / 4

Hh	Hv	
1003	1904 - 3403	
403	1303 - 1903	

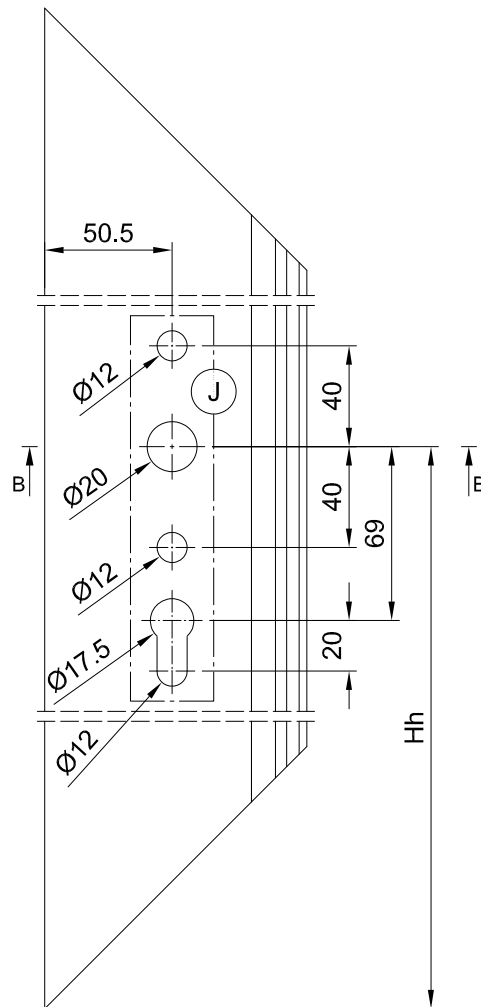
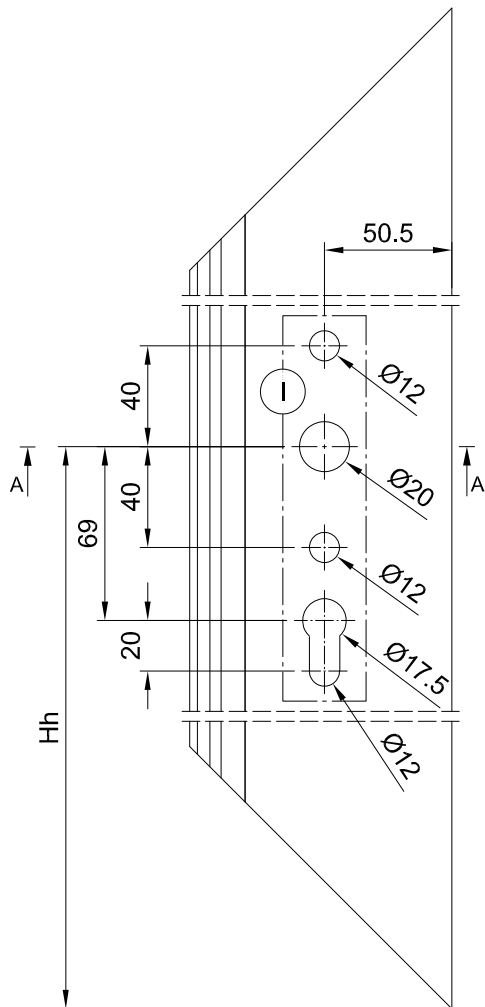
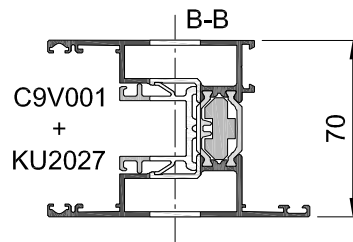
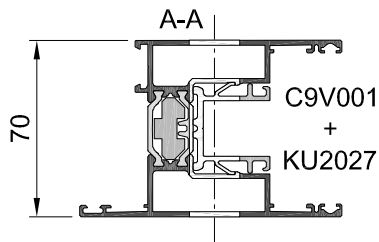
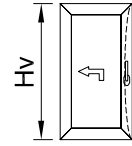



PREPARAZIONE ANTE

INSTALLAZIONE GUARNIZIONE RU0099 PER ALZANTE-SCORREVOLE

1 / 2

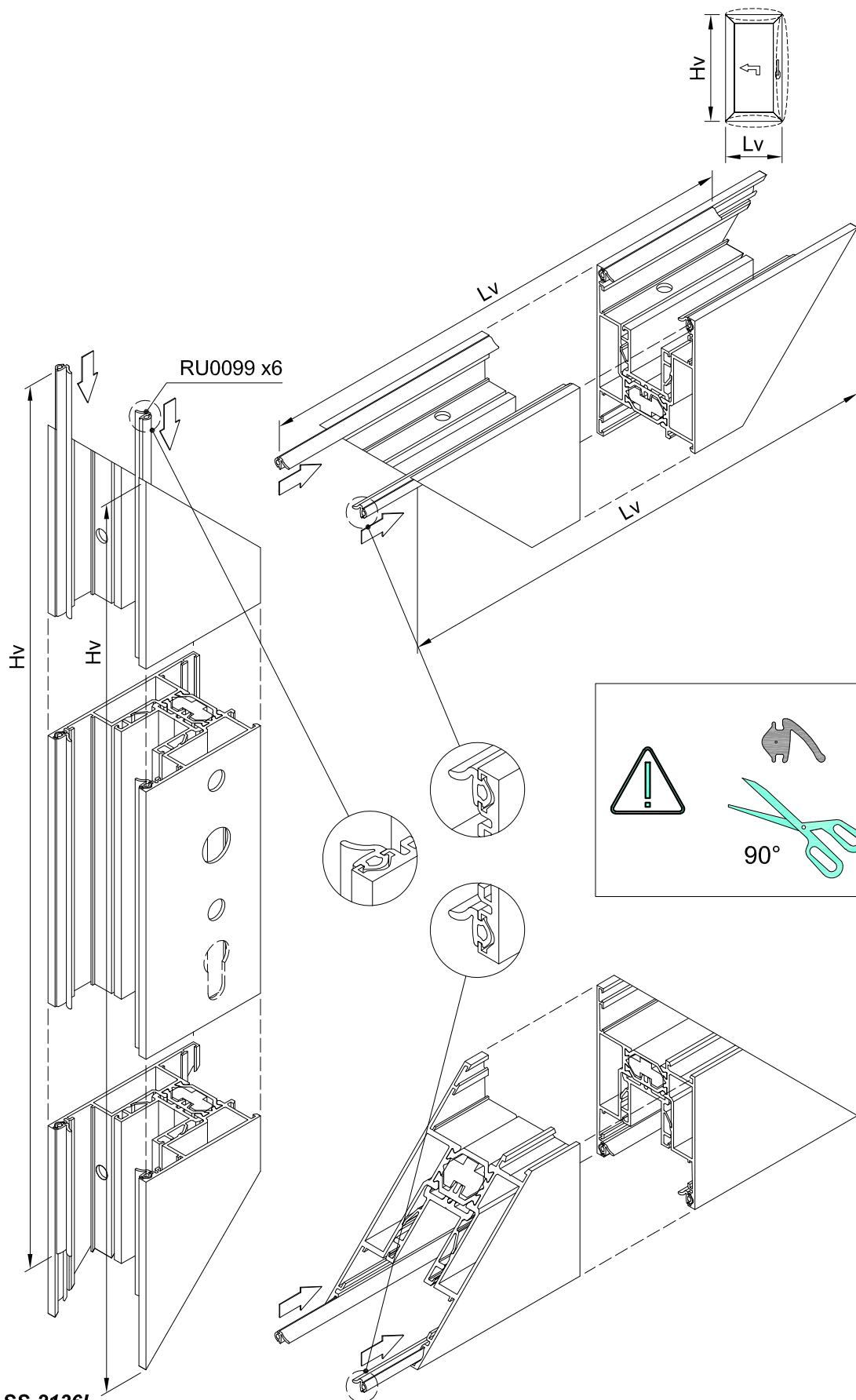

INSTALLAZIONE GUARNIZIONE RU0099 PER ALZANTE-SCORREVOLE

2 / 2

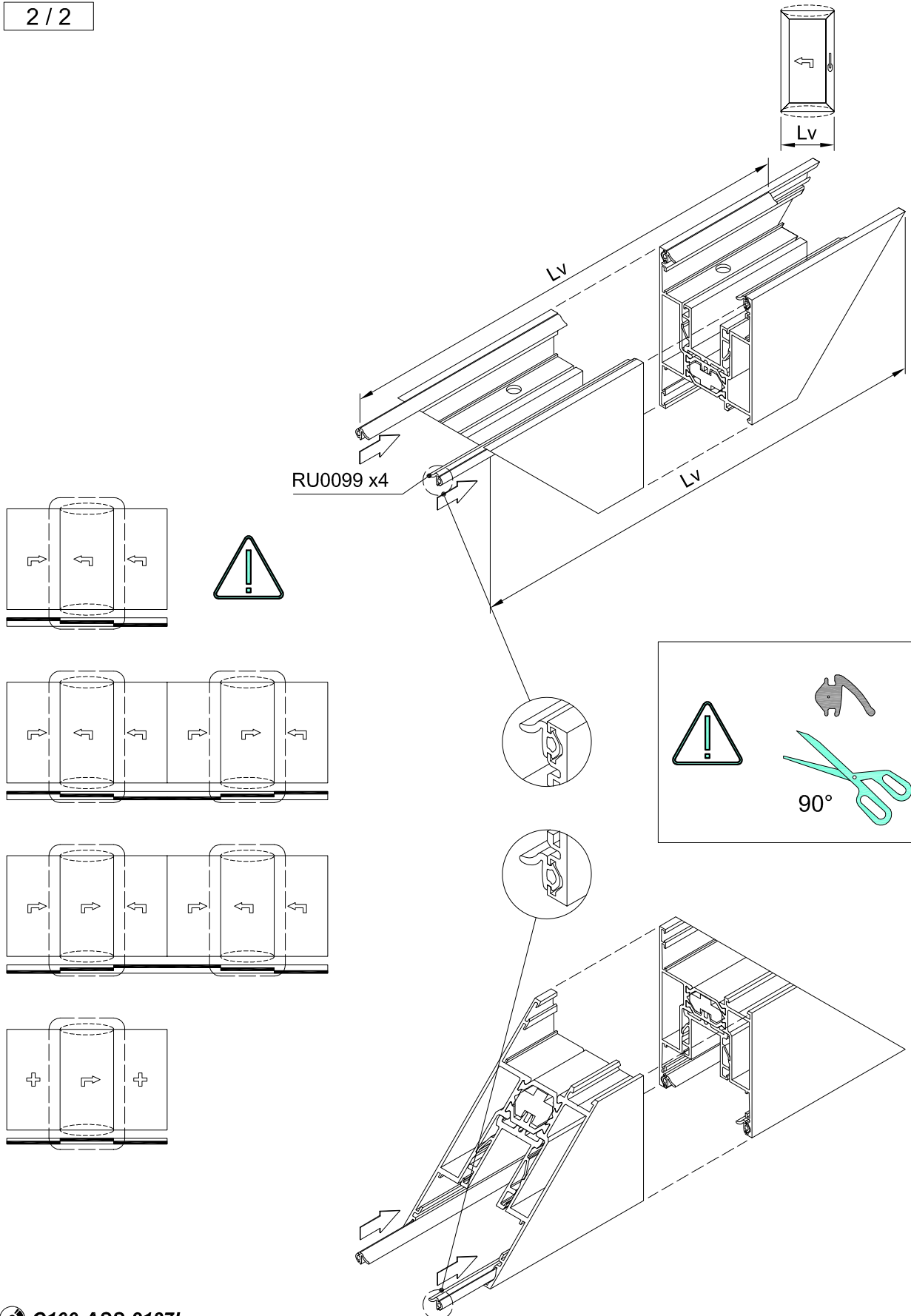



ASSEMBLAGGIO PROFILATO ANTA CON SQUADRETTE

2 / 3

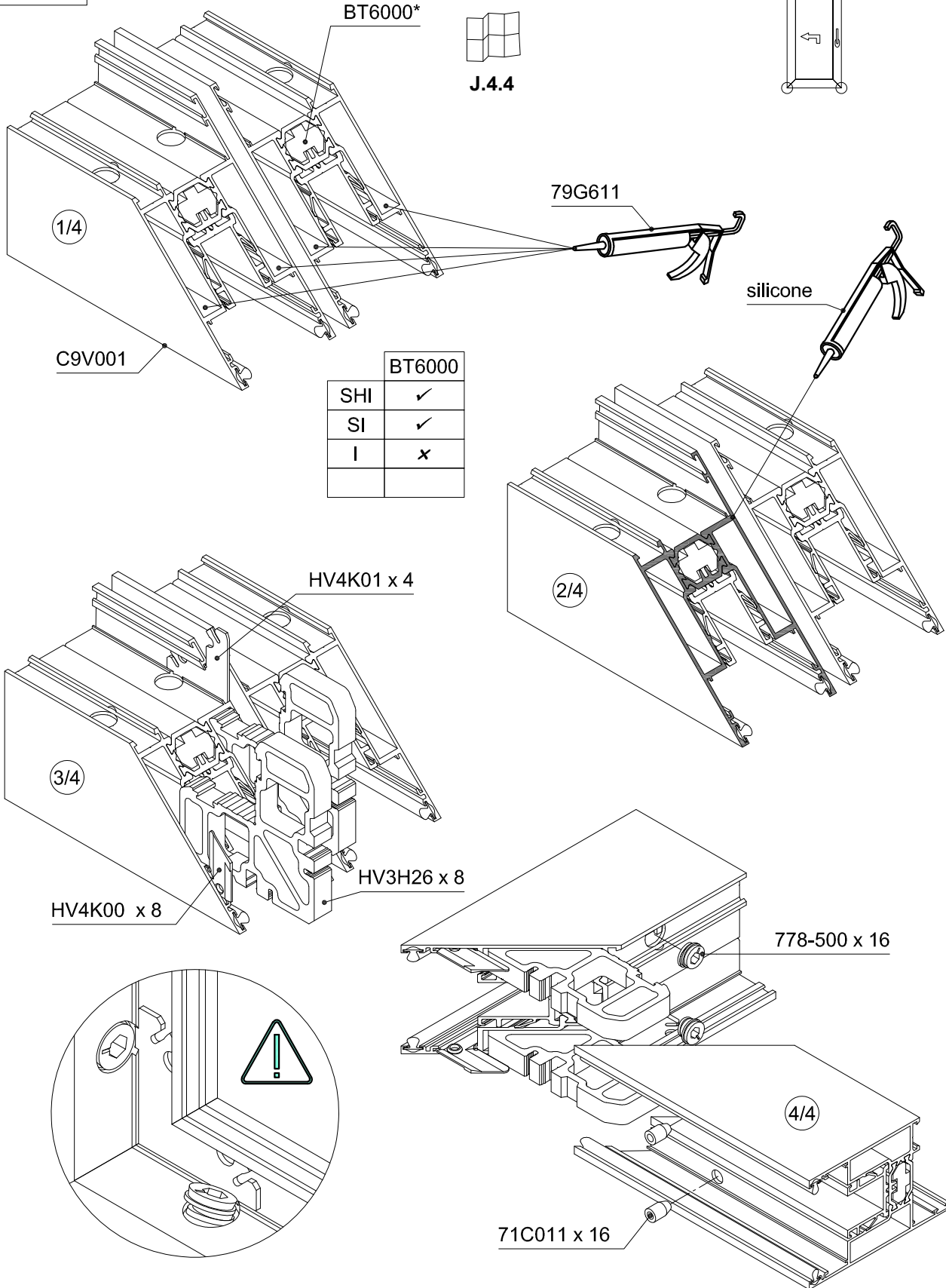



ASSEMBLAGGIO PROFILATO ANTA CON SQUADRETTE

3 / 3

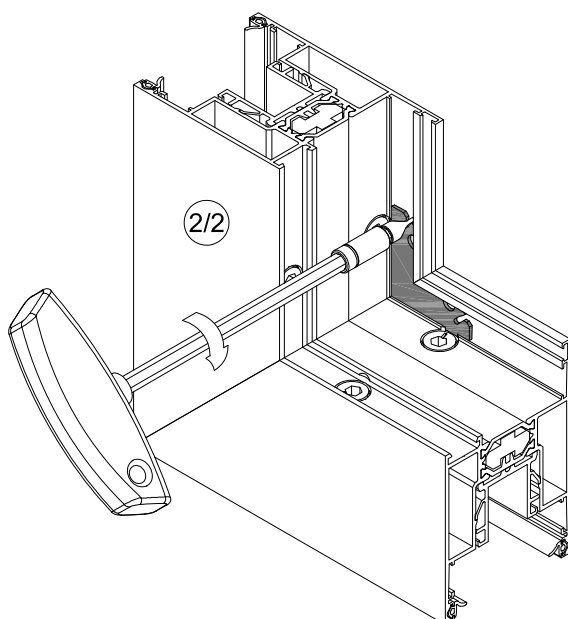
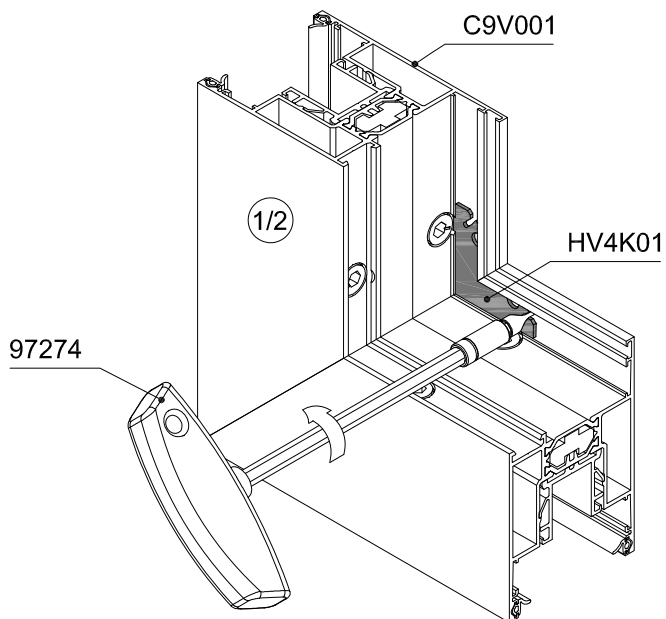
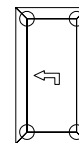



FERRAMENTA & DISEGNI ASSEMBLAGGIO

PREPARAZIONE ANTE



ASSEMBLAGGIO FERRAMENTA ANTA

FERRAMENTA ALZANTE-SCORREVOLE - PANORAMICA

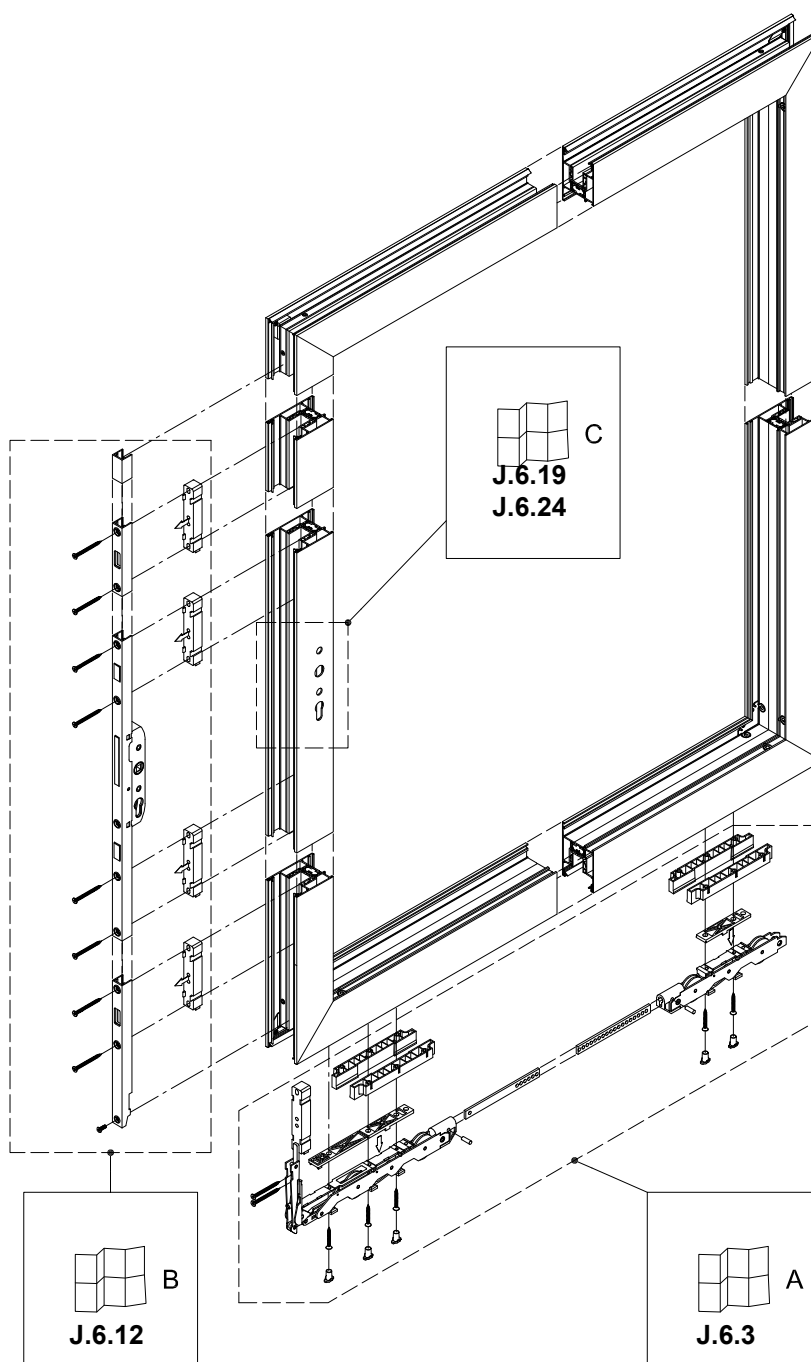
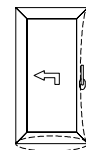

CONTENUTO

Assemblaggio ferramenta anta.....	J.6.1
Ferramenta alzante-scorrevole - panoramica.....	J.6.1
Contenuto.....	J.6.2
Preparazione carrelli alzante-scorrevole.....	J.6.3
Preparazione carrelli alzante-scorrevole (300 - 400 kg) - optional.....	J.6.5
Preparazione ZB0033/ZB0034/ZB0035/ZB0036.....	J.6.12
Preparazione ZB0033/ZB0034/ZB0035/ZB0036 - maniglia interna.....	J.6.13
Assemblaggio ZB0053/ZB0054 - sollevamento servo assistito.....	J.6.14
Preparazione ZB0046.....	J.6.15
Assemblaggio ZB0035/ZB0036 con ZB0046.....	J.6.16
Installazione chiusura meccanismo alzante-scorrevole.....	J.6.17
Installazione maniglia interna standard con mezzo cilindro alzante-scorrevole....	J.6.21
Maniglia interna standard con mezzo cilindro e vaschetta alzante-scorrevole.....	J.6.22
Installazione maniglia interna S-line Harmony alzante-scorrevole.....	J.6.24
Maniglia interna S-line Harmony e vaschetta esterna alzante-scorrevole.....	J.6.25
Installazione maniglia interna S-line Harmony con mezzo cilindro alzante-scorrevole	J.6.26
Maniglia interna S-line Harmony con mezzo cilindro e vaschetta alzante-scorrevole	J.6.27
Installazione maniglia S-Line Harmony su due lati con cilindro alzante-scorrevole	J.6.28



ASSEMBLAGGIO FERRAMENTA ANTA

PREPARAZIONE CARRELLI ALZANTE-SCORREVOLE

1 / 9



≤ 300 kg

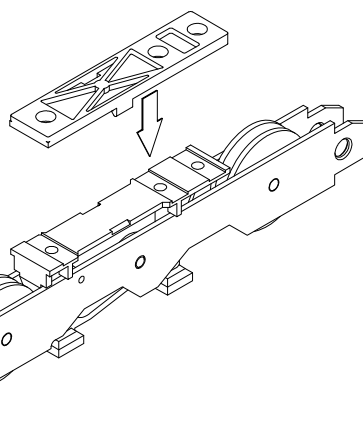
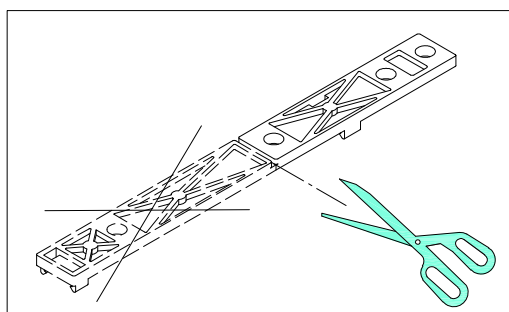
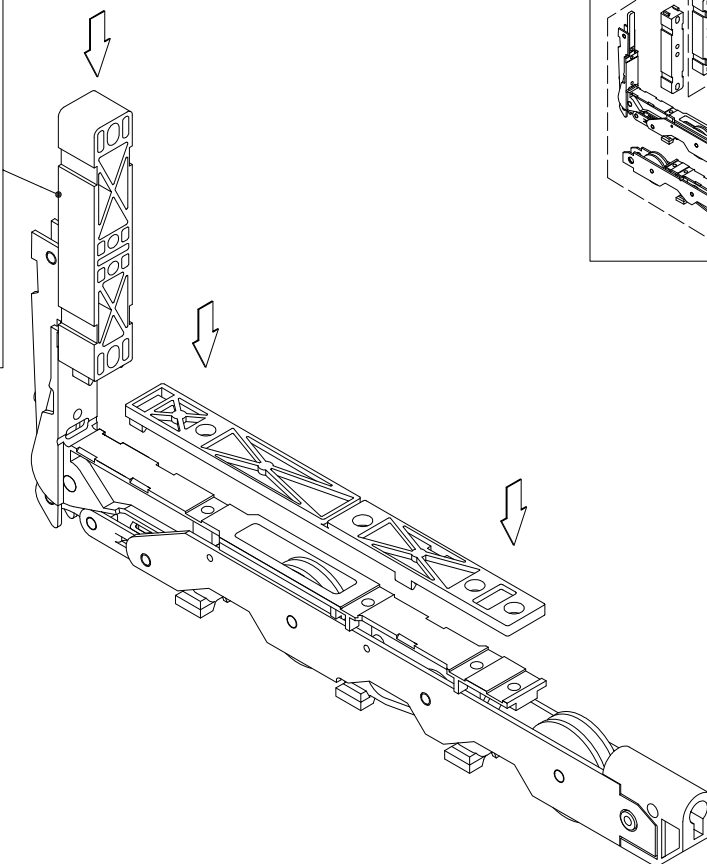
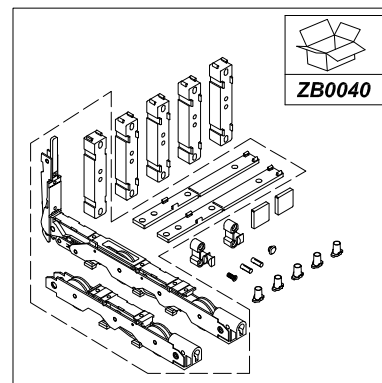
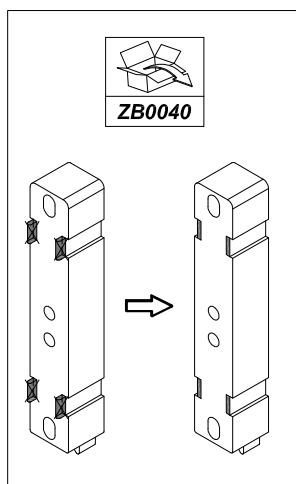
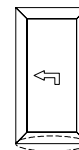

PREPARAZIONE CARRELLI ALZANTE-SCORREVOLI

2 / 9



≤ 300 kg

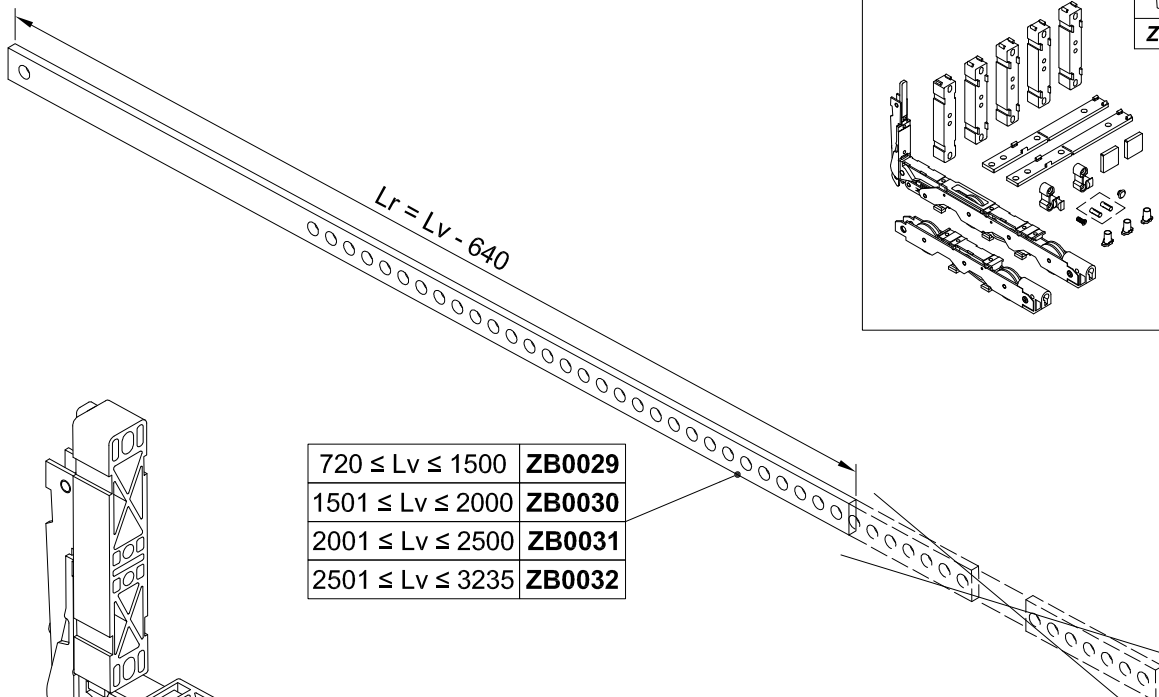
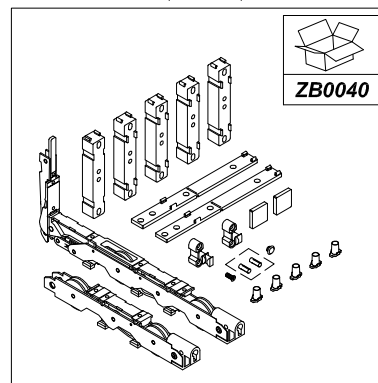
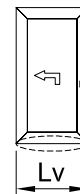

$720 \leq L_v \leq 1500$	ZB0029
$1501 \leq L_v \leq 2000$	ZB0030
$2001 \leq L_v \leq 2500$	ZB0031
$2501 \leq L_v \leq 3235$	ZB0032

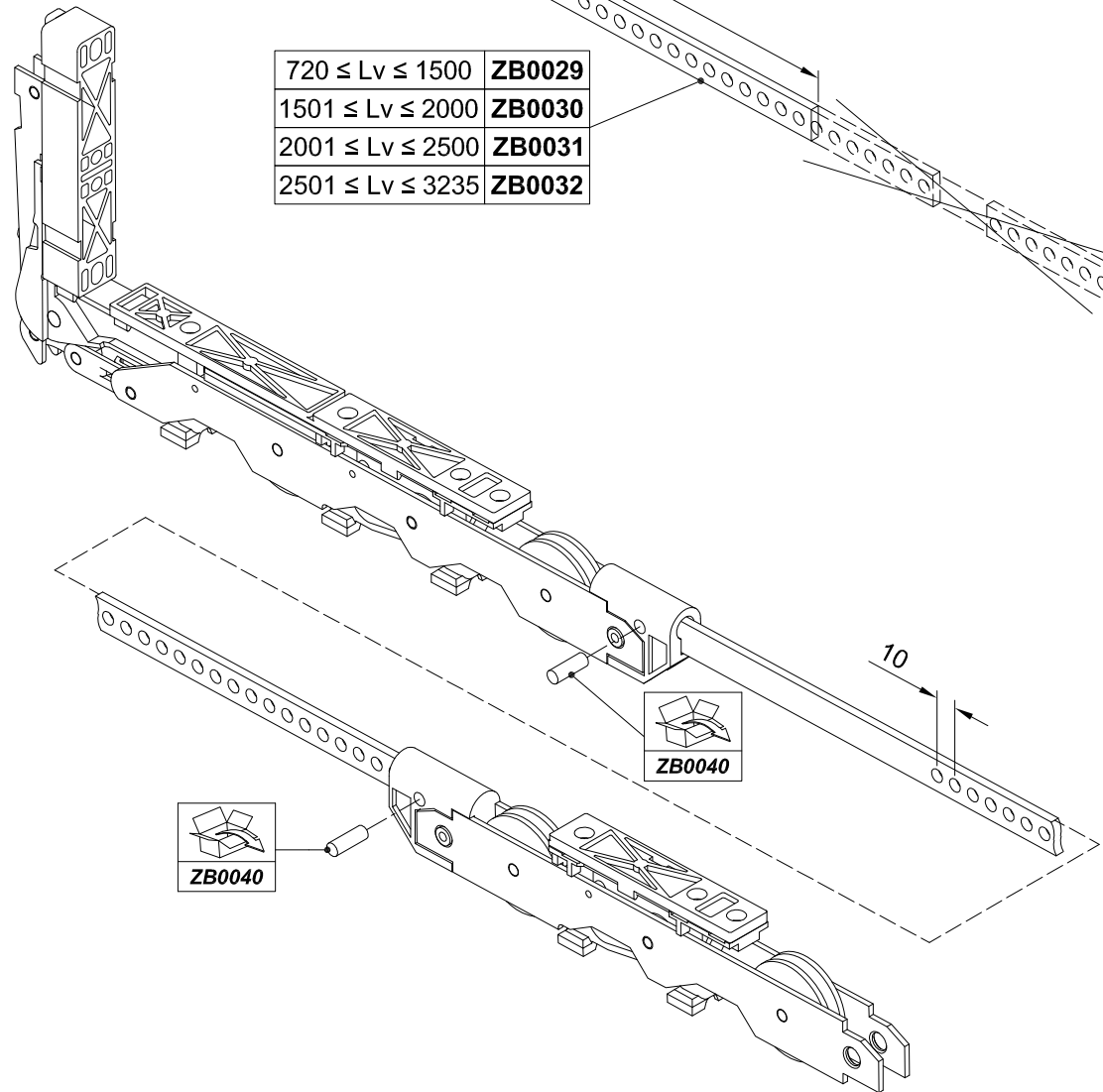



ASSEMBLAGGIO FERRAMENTA ANTA

PREPARAZIONE CARRELLI ALZANTE-SCORREVOLE (300 - 400 KG) - OPTIONAL

3 / 9

300 kg <  ≤ 400 kg

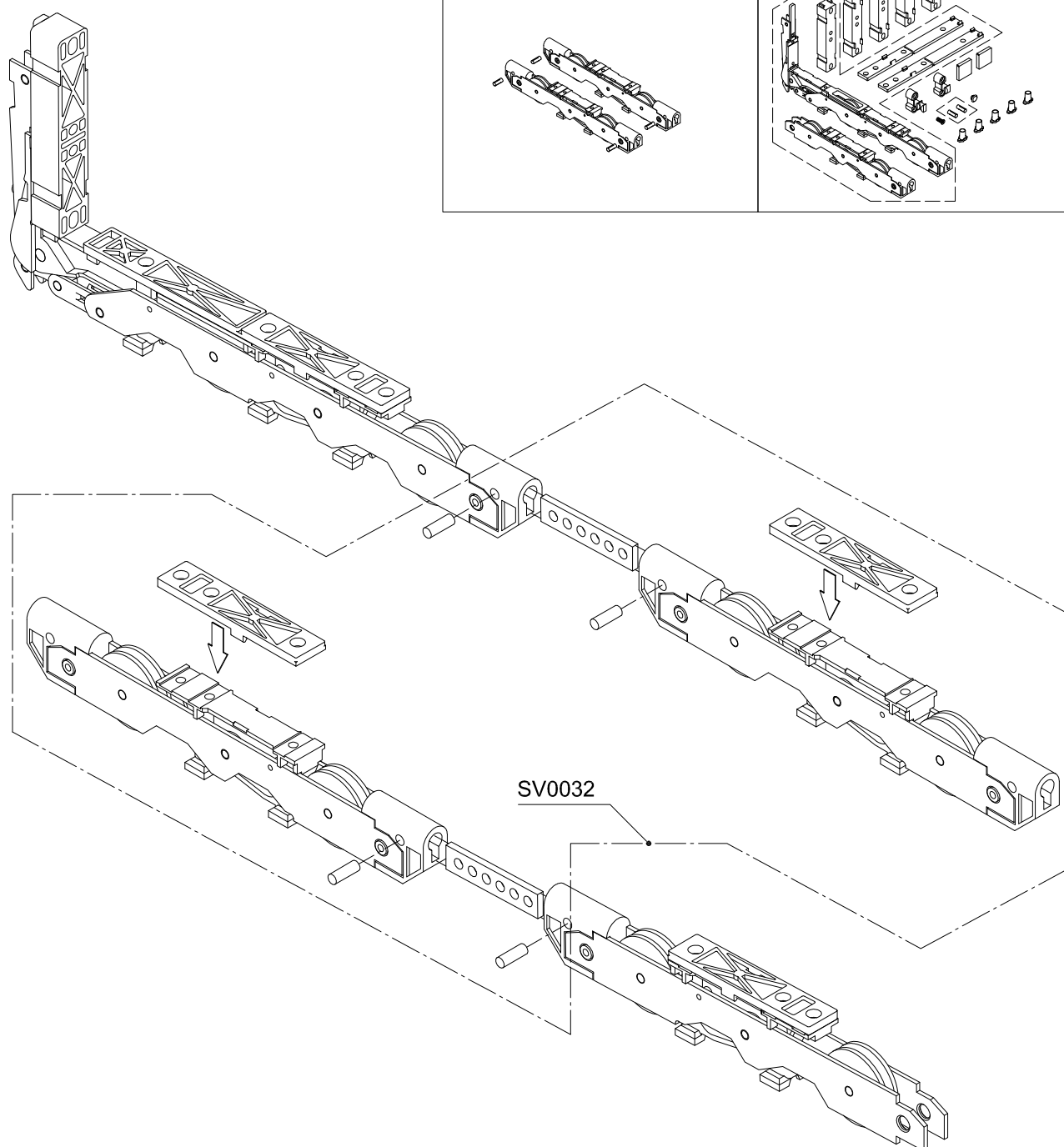
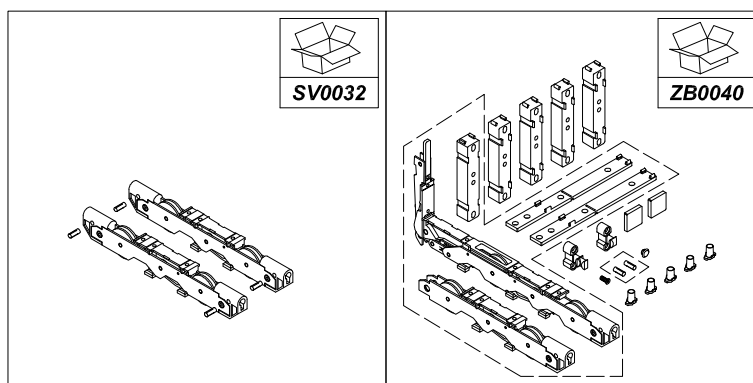
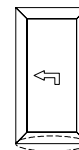

PREPARAZIONE CARRELLI ALZANTE-SCORREVOLE (300 - 400 KG) - OPTIONAL

4 / 9

300 kg <  ≤ 400 kg

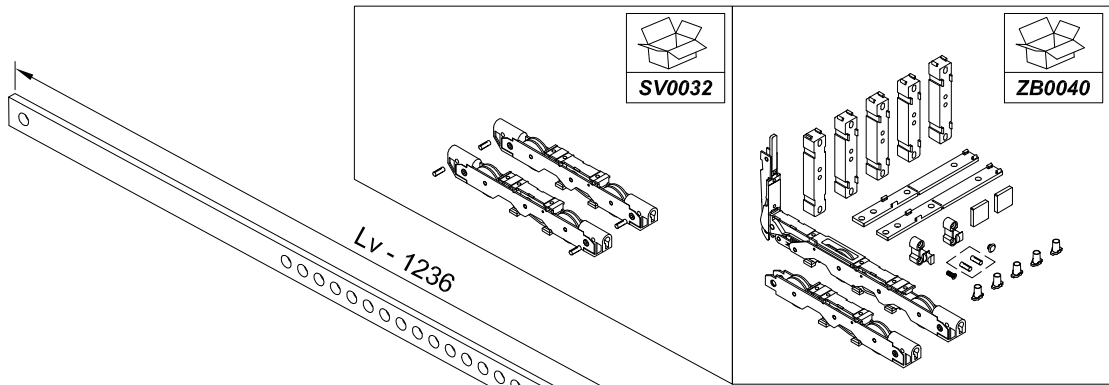
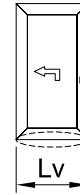

$1316 \leq Lv \leq 1500$	ZB0029
$1501 \leq Lv \leq 2000$	ZB0030
$2001 \leq Lv \leq 2500$	ZB0031
$2501 \leq Lv \leq 3235$	ZB0032

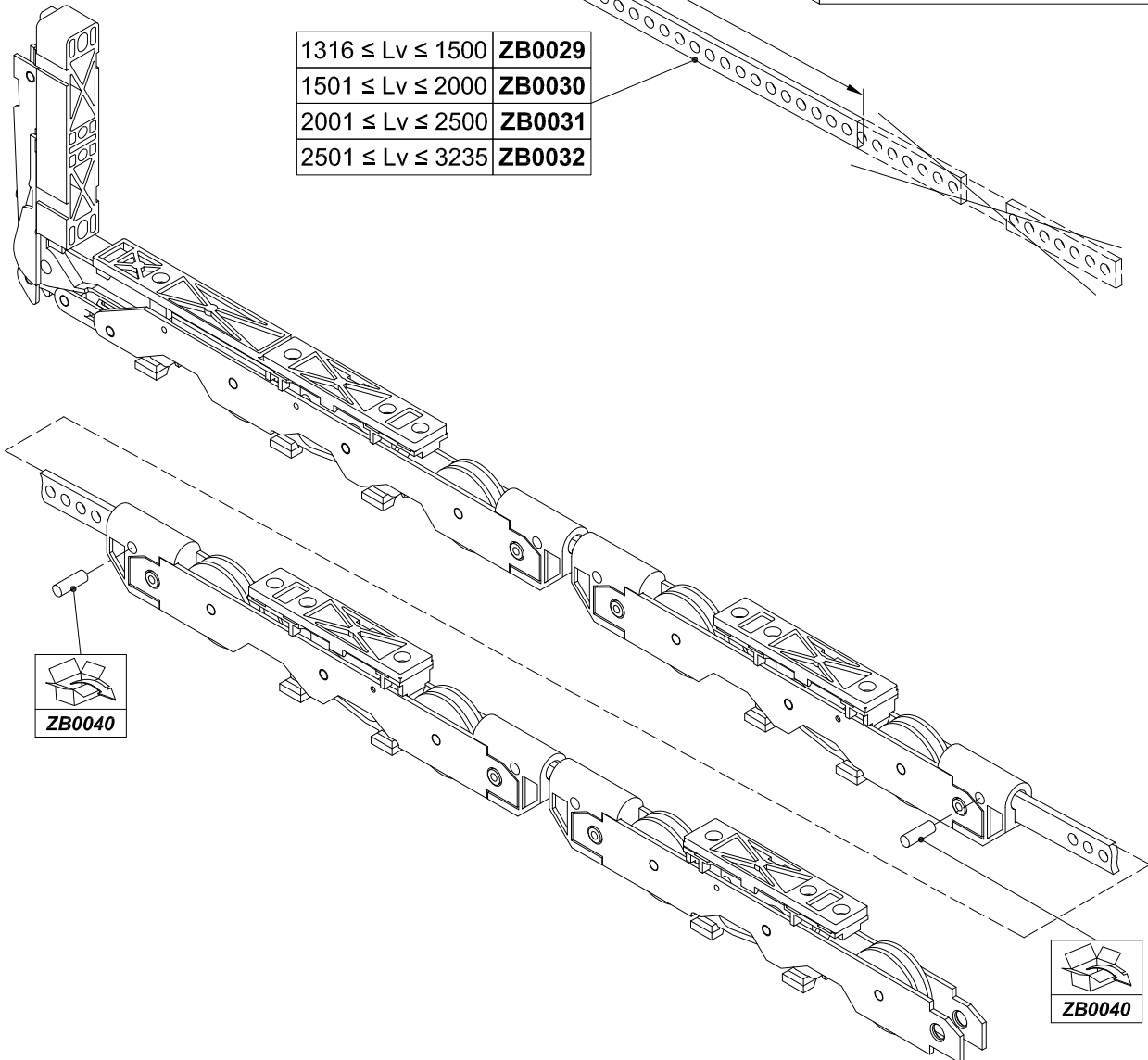



ASSEMBLAGGIO FERRAMENTA ANTA

INSTALLAZIONE CARRELLI ALZANTE-SCORREVOLE

5 / 9



≤ 300 kg

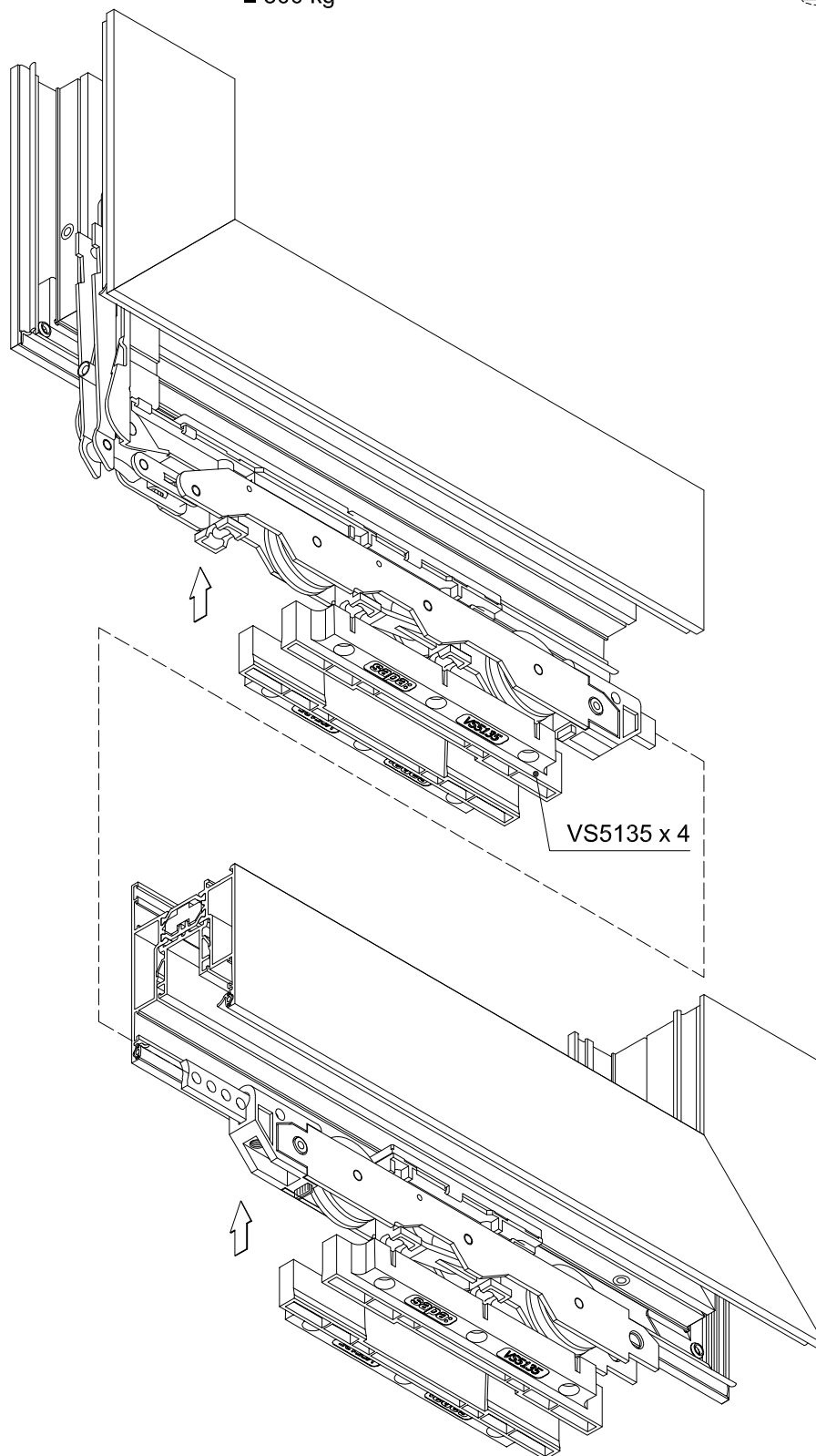
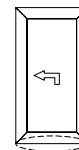

INSTALLAZIONE CARRELLI ALZANTE-SCORREVOLE

6 / 9



≤ 300 kg

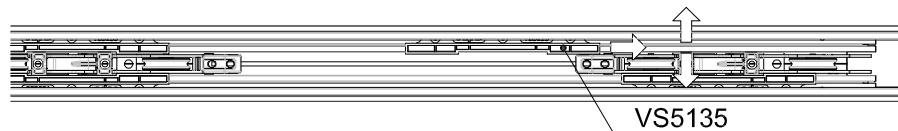
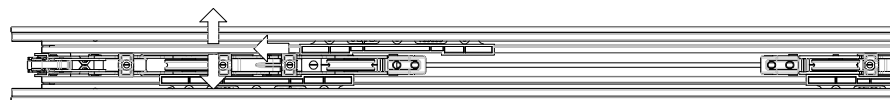
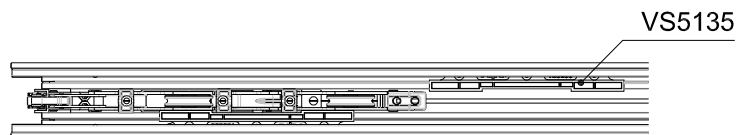
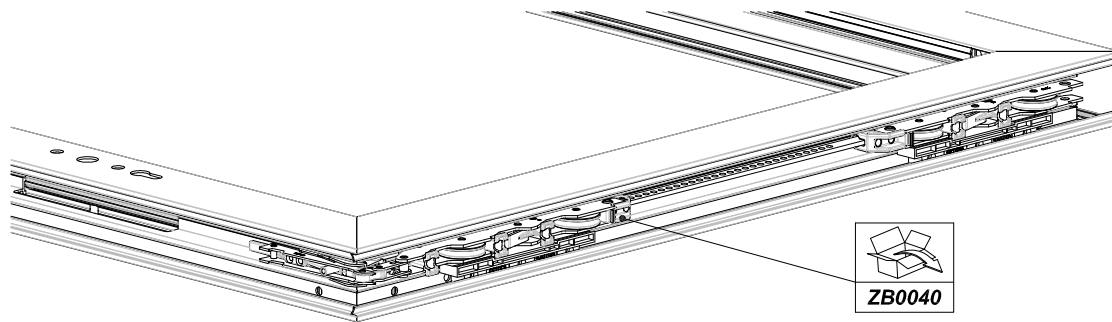
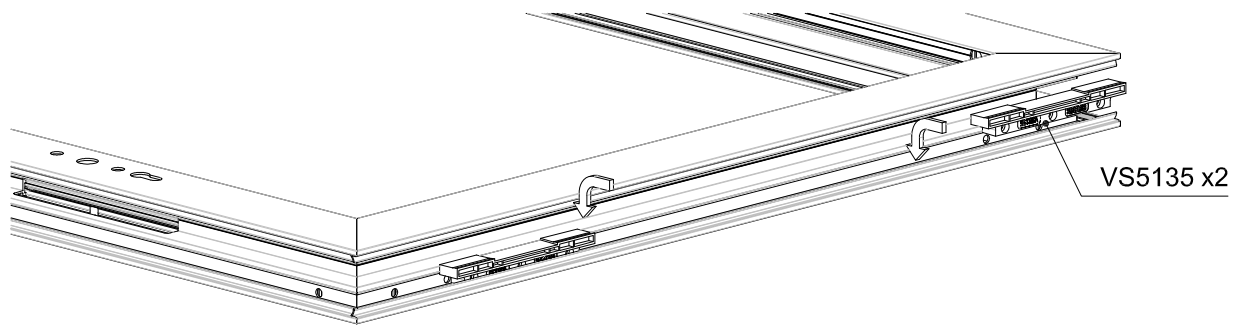
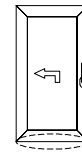



ASSEMBLAGGIO FERRAMENTA ANTA

INSTALLAZIONE CARRELLI ALZANTE-SCORREVOLE

7 / 9



≤ 300 kg

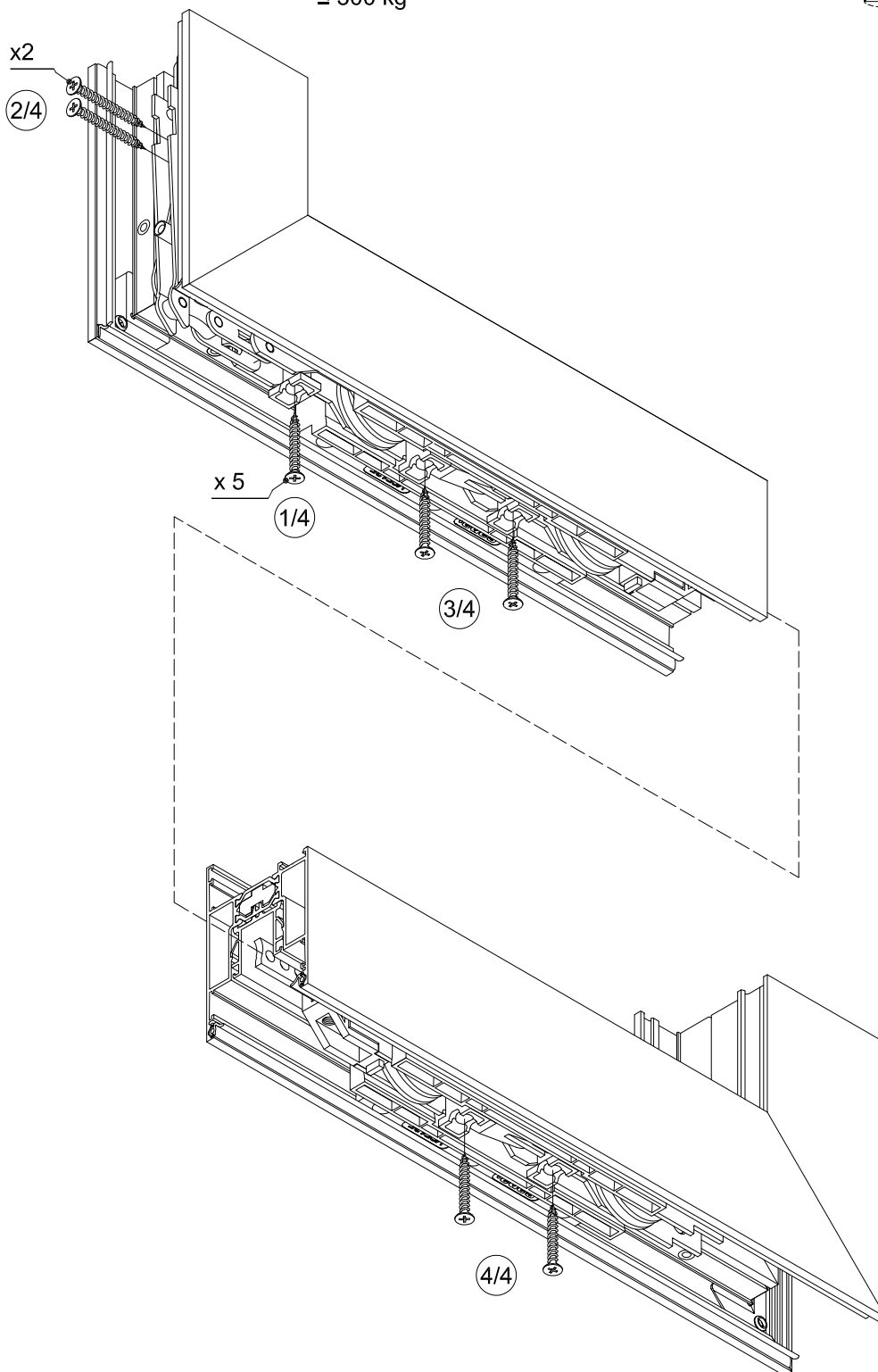
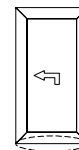

INSTALLAZIONE CARRELLI ALZANTE-SCORREVOLE

8 / 9



≤ 300 kg

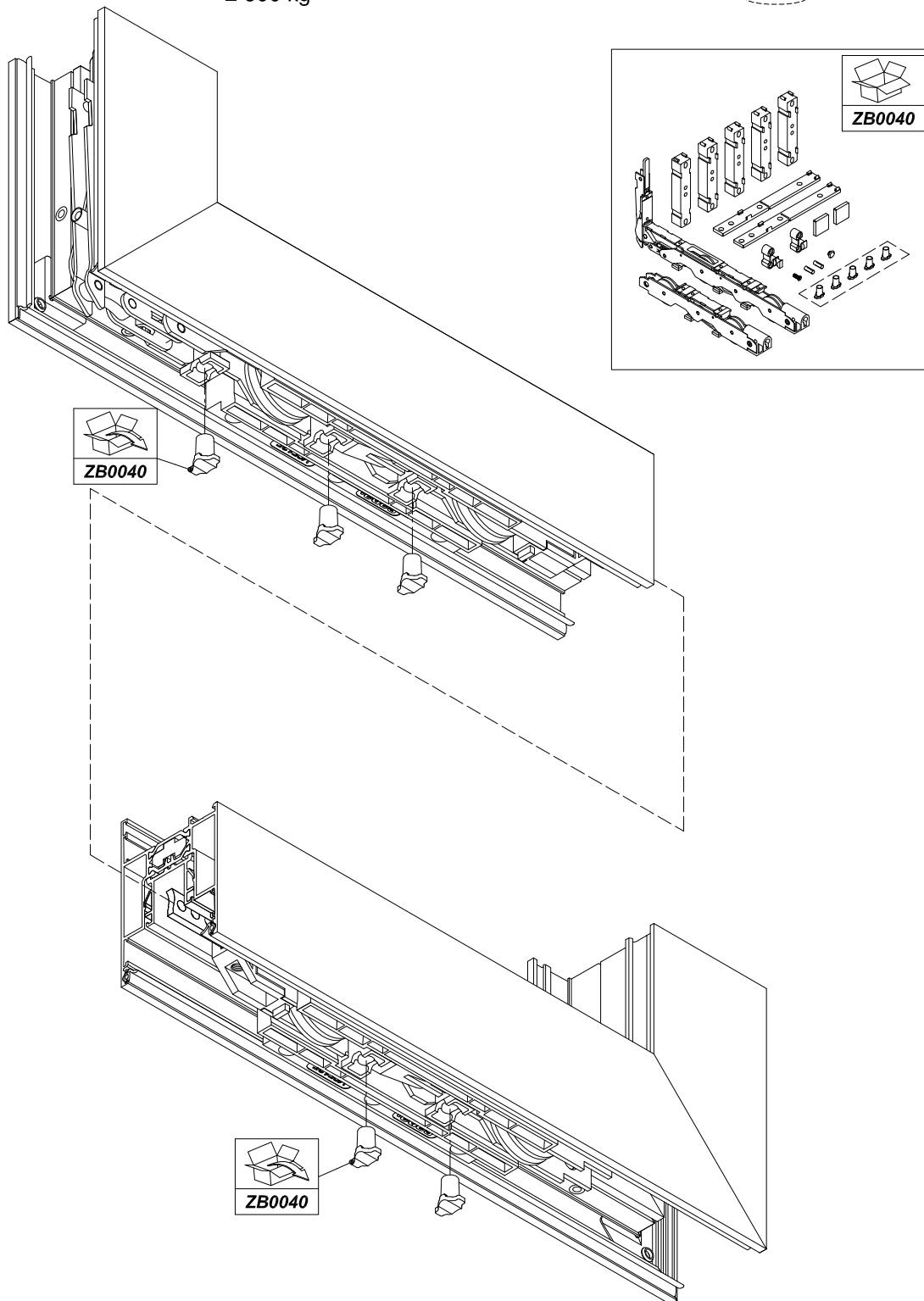
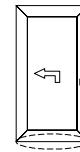



ASSEMBLAGGIO FERRAMENTA ANTA

INSTALLAZIONE CARRELLI ALZANTE-SCORREVOLE

9 / 9



≤ 300 kg

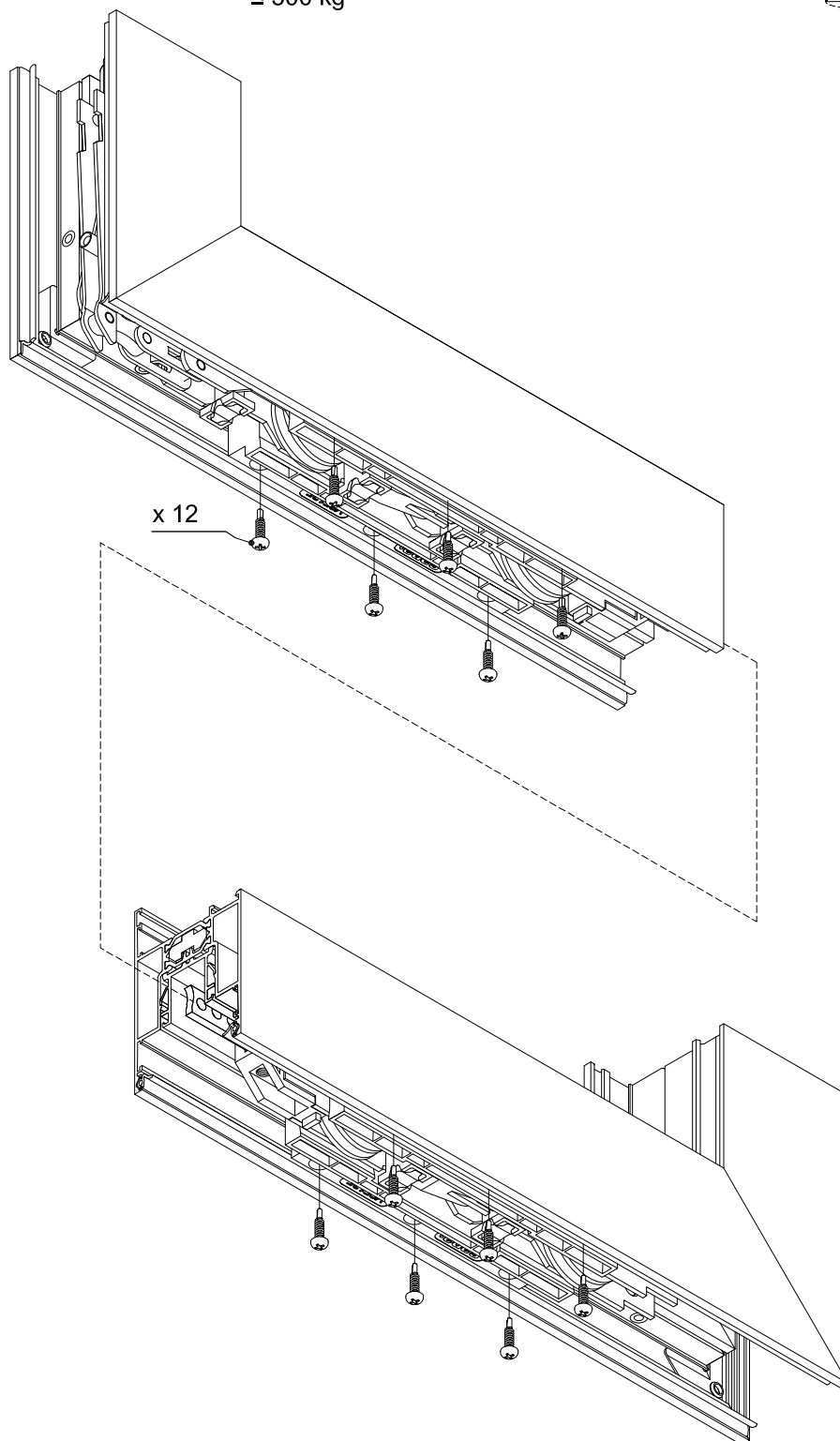
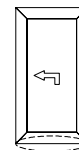

PREPARAZIONE ZB0033/ZB0034/ZB0035/ZB0036

1 / 8

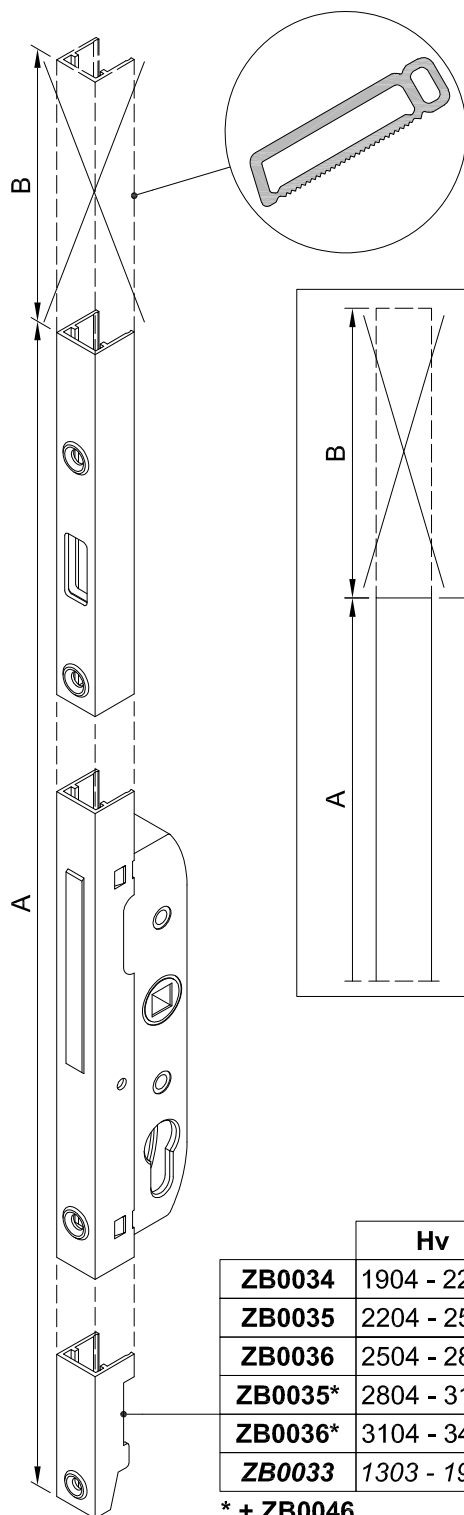
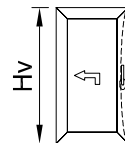

	Hv	A	B
ZB0034	1904 - 2203	Hv - 103	2203 - Hv
ZB0035	2204 - 2503		2503 - Hv
ZB0036	2504 - 2803		2803 - Hv
ZB0035*	2804 - 3103	Hv - 703	3103 - Hv
ZB0036*	3104 - 3403		3403 - Hv
ZB0033	1303 - 1903	Hv - 103	1903 - Hv

* + ZB0046



ASSEMBLAGGIO FERRAMENTA ANTA

PREPARAZIONE ZB0033/ZB0034/ZB0035/ZB0036 - MANIGLIA INTERNA

2 / 8

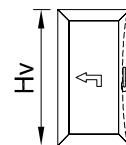

	Hv
ZB0034	1904 - 2203
ZB0035	2204 - 2503
ZB0036	2504 - 2803
ZB0035*	2804 - 3103
ZB0036*	3104 - 3403
ZB0033	1303 - 1903

* + ZB0046

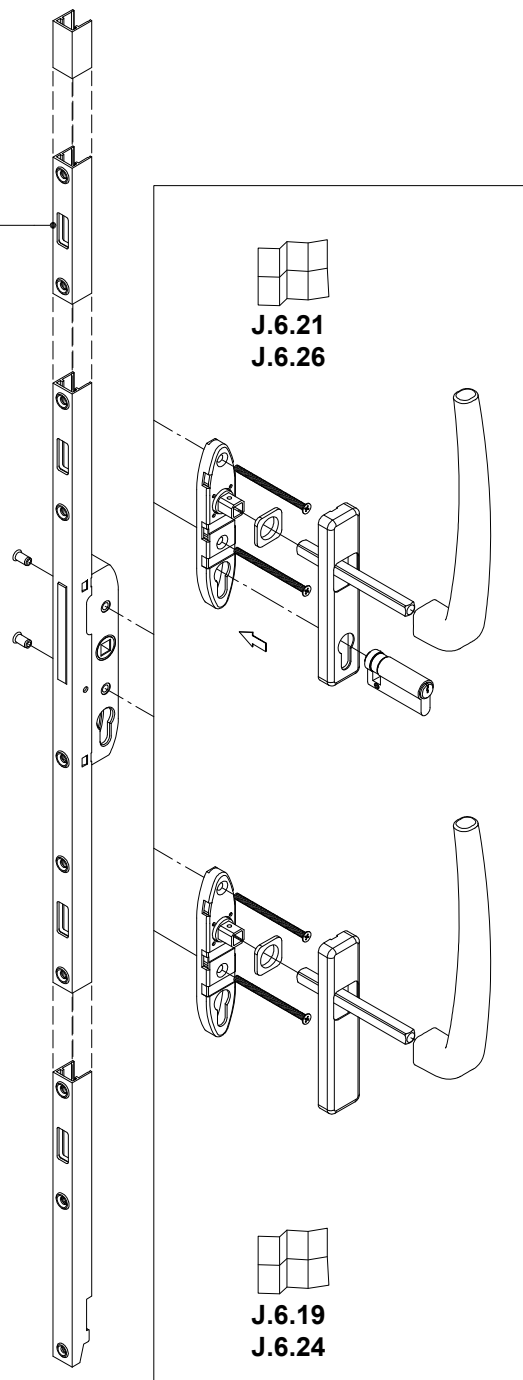
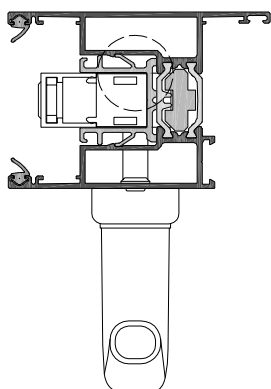
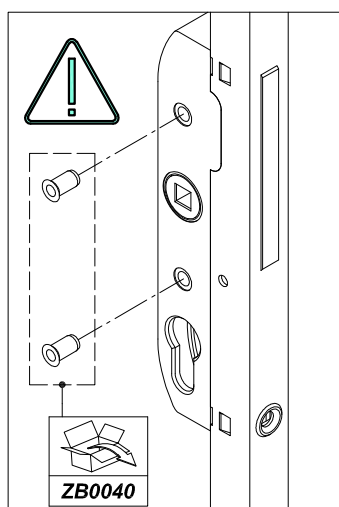

ASSEMBLAGGIO ZB0053/ZB0054 - SOLLEVAMENTO SERVO ASSISTITO

3 / 8

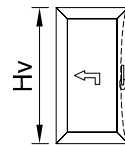

	Hv
ZB0034	1904 - 2203
ZB0035	2204 - 2503
ZB0036	2504 - 2803
ZB0035*	2804 - 3103
ZB0036*	3104 - 3403
ZB0033	1303 - 1903

* + ZB0046

ZB0053	= 100 kg - 200 kg
ZB0054	= 201 kg - 400 kg

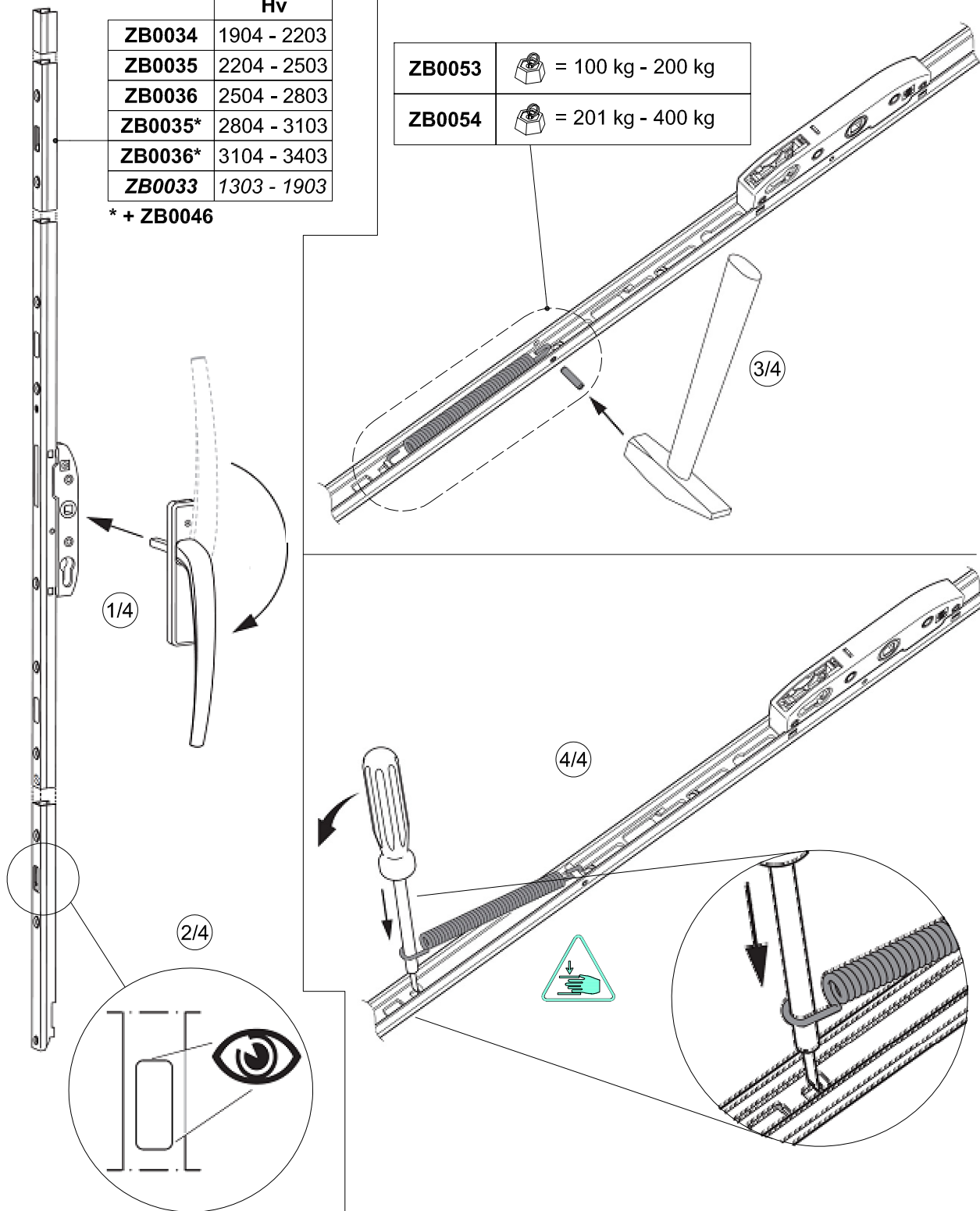

C160-ASS-2156L



ASSEMBLAGGIO FERRAMENTA ANTA

PREPARAZIONE ZB0046

4 / 8

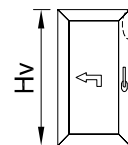

	Hv	B
ZB0035*	2804 - 3103	3103 - Hv
ZB0036*	3104 - 3403	3403 - Hv

* + ZB0046

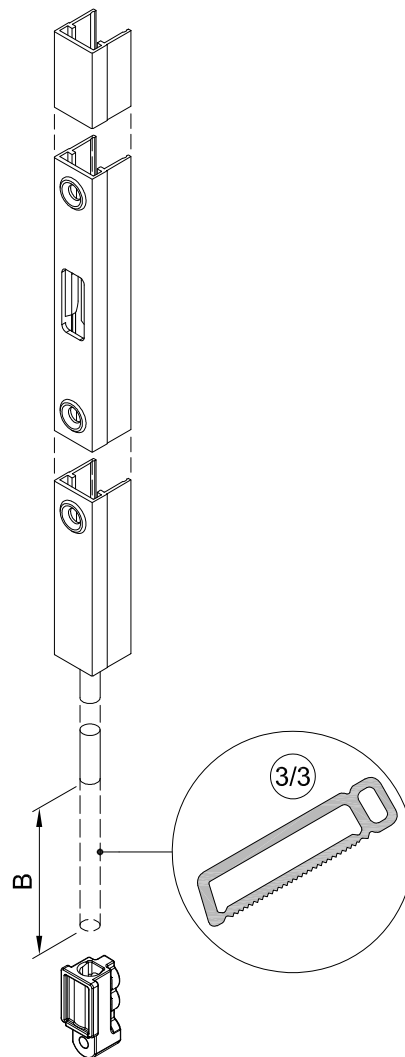
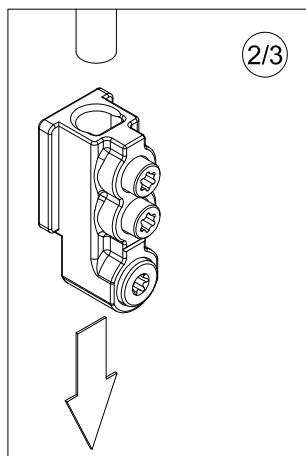
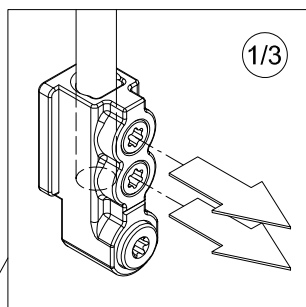
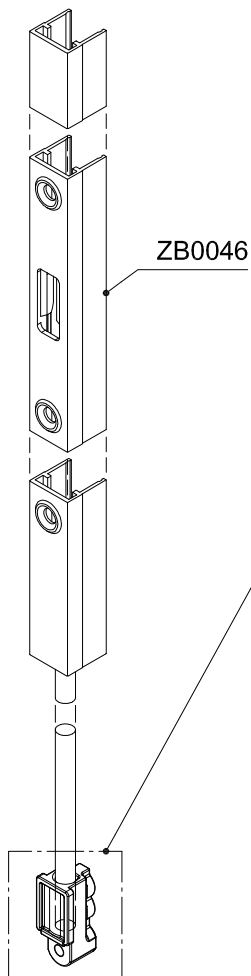

ASSEMBLAGGIO ZB0035/ZB0036 CON ZB0046

5 / 8

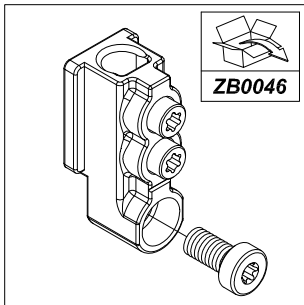
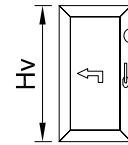

	Hv
ZB0035*	2804 - 3103
ZB0036*	3104 - 3403

* + ZB0046

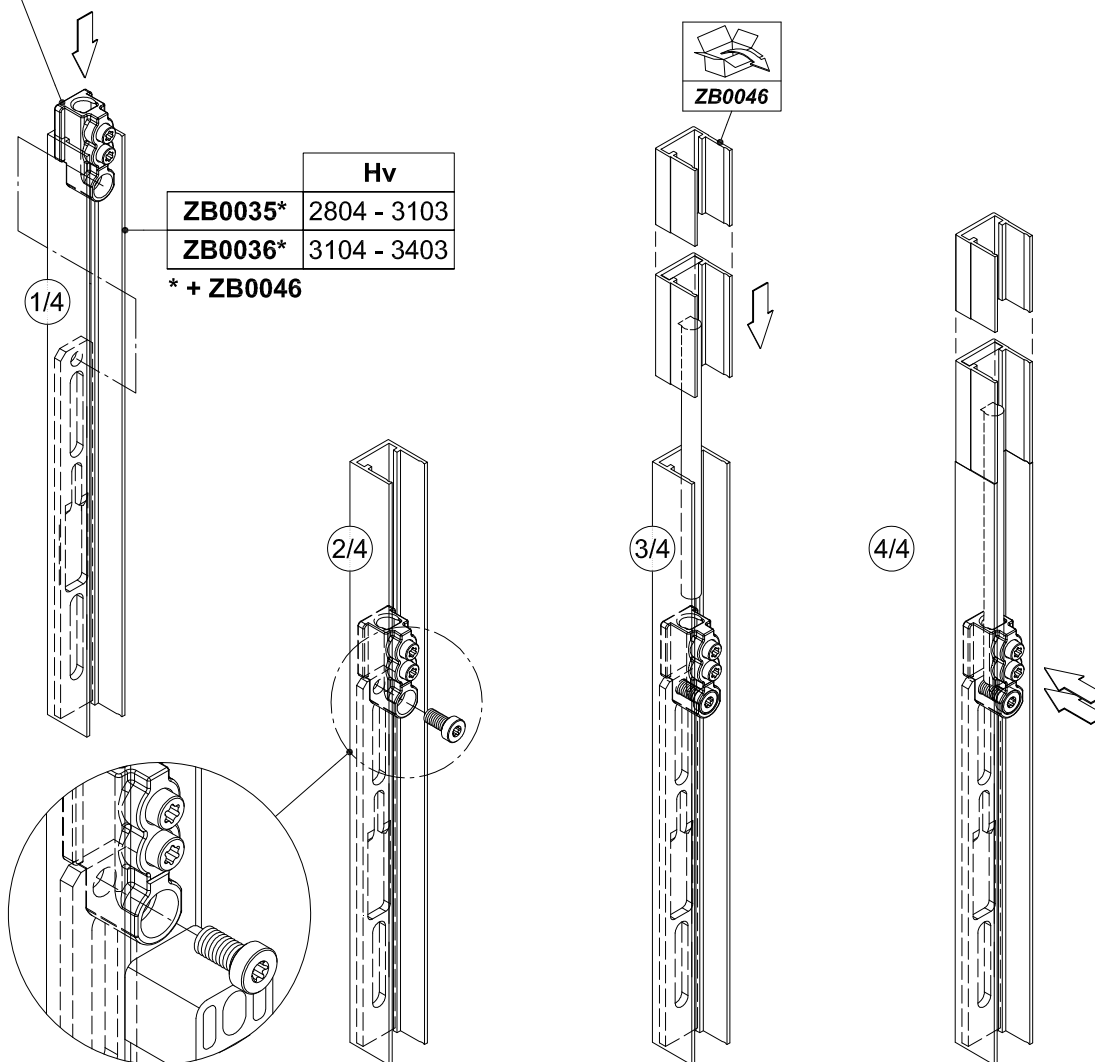



ASSEMBLAGGIO FERRAMENTA ANTA

INSTALLAZIONE CHIUSURA MECCANISMO ALZANTE-SCORREVOLE

2 / 5

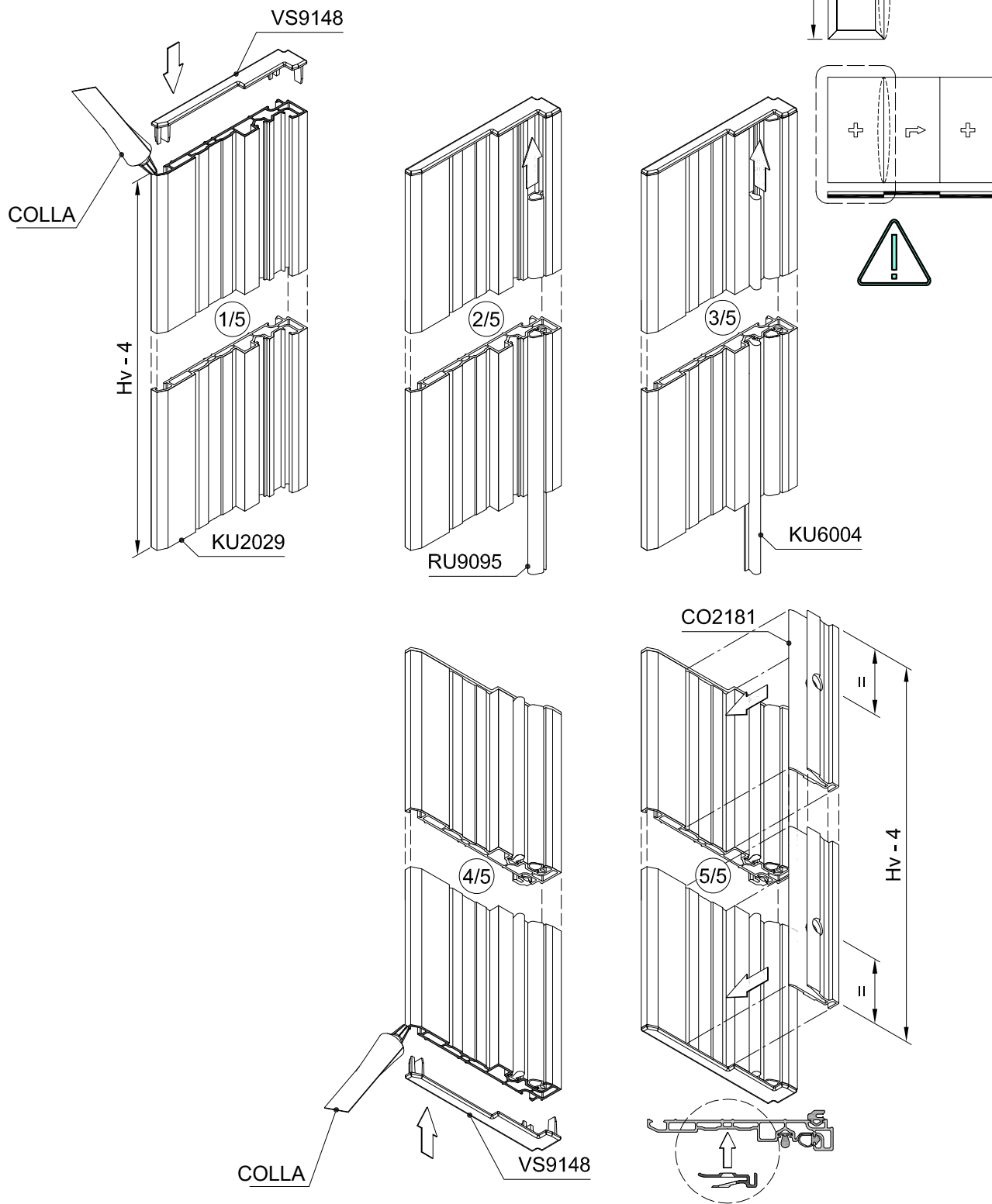

INSTALLAZIONE CHIUSURA MECCANISMO ALZANTE-SCORREVOLE - ANTA PASSIVA SCHEMA 4 ANTE

7 / 8

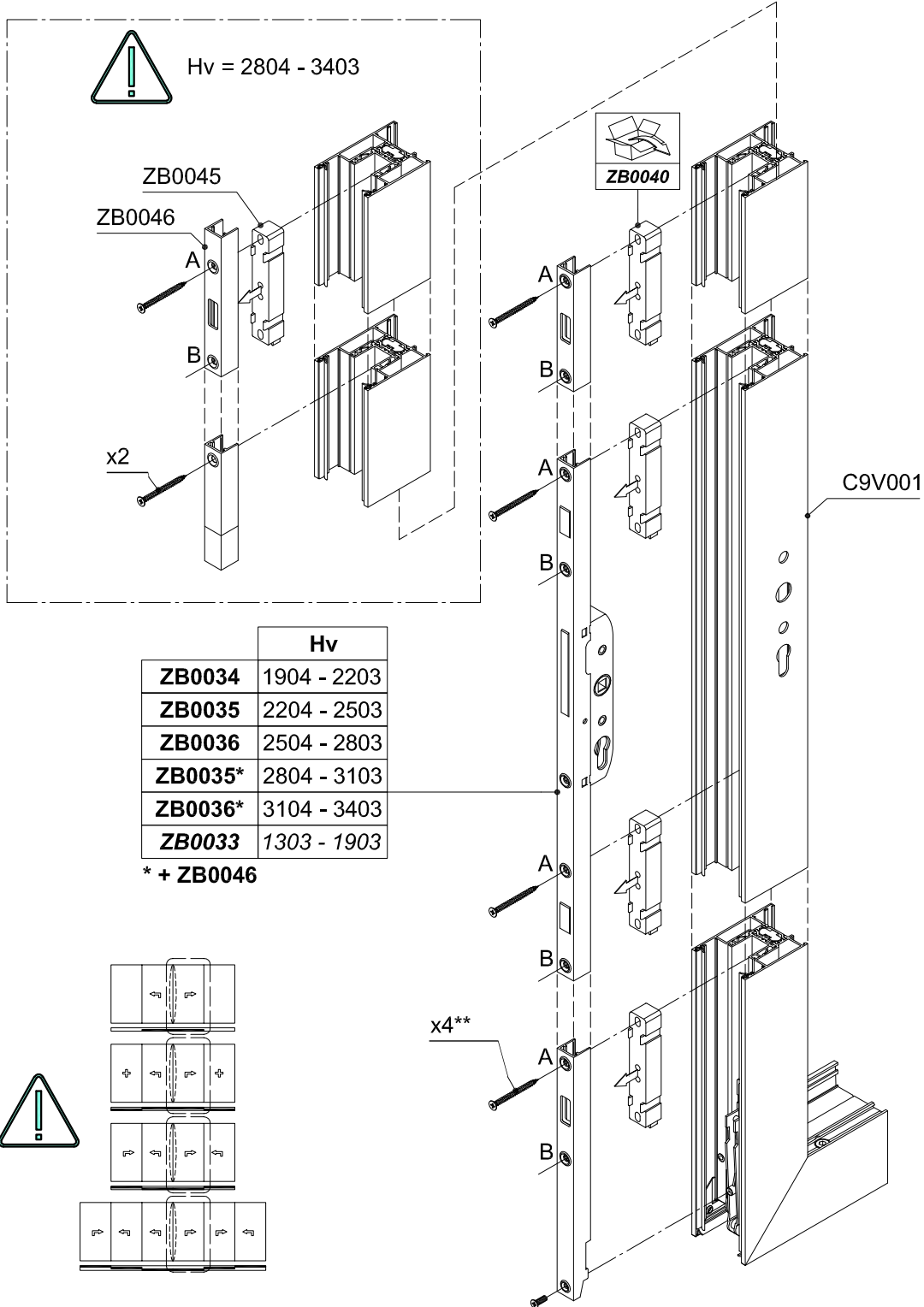
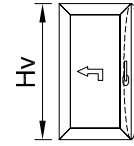

	Hv
ZB0034	1904 - 2203
ZB0035	2204 - 2503
ZB0036	2504 - 2803
ZB0035*	2804 - 3103
ZB0036*	3104 - 3403
ZB0033	1303 - 1903

* + ZB0046

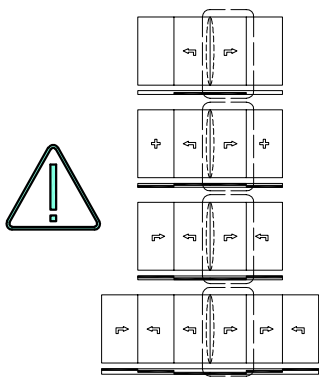



ASSEMBLAGGIO FERRAMENTA ANTA

INSTALLAZIONE MANIGLIA INTERNA STANDARD ALZANTE-SCORREVOLE

1 / 5

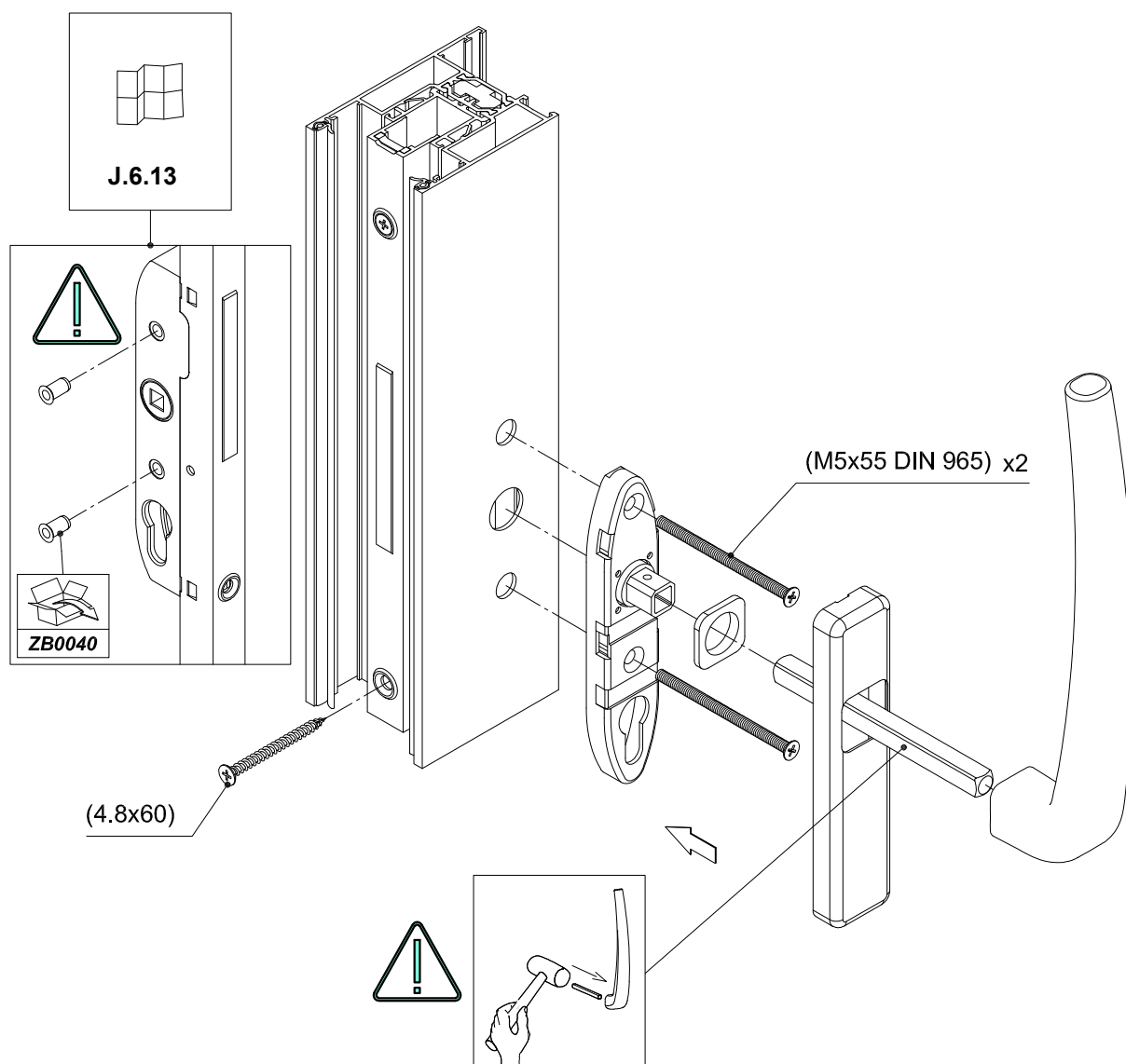
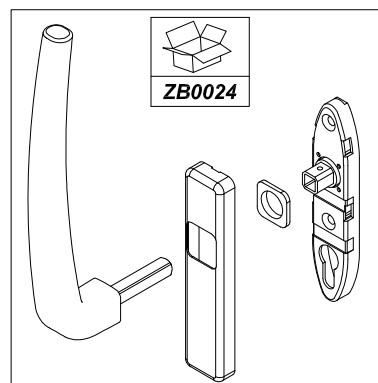
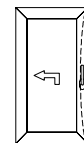

 C160-ASS-2169L

INSTALLAZIONE MANIGLIA INTERNA STANDARD E VASCHETTA ESTERNA ALZANTE-SCORREVOLE

2 / 5

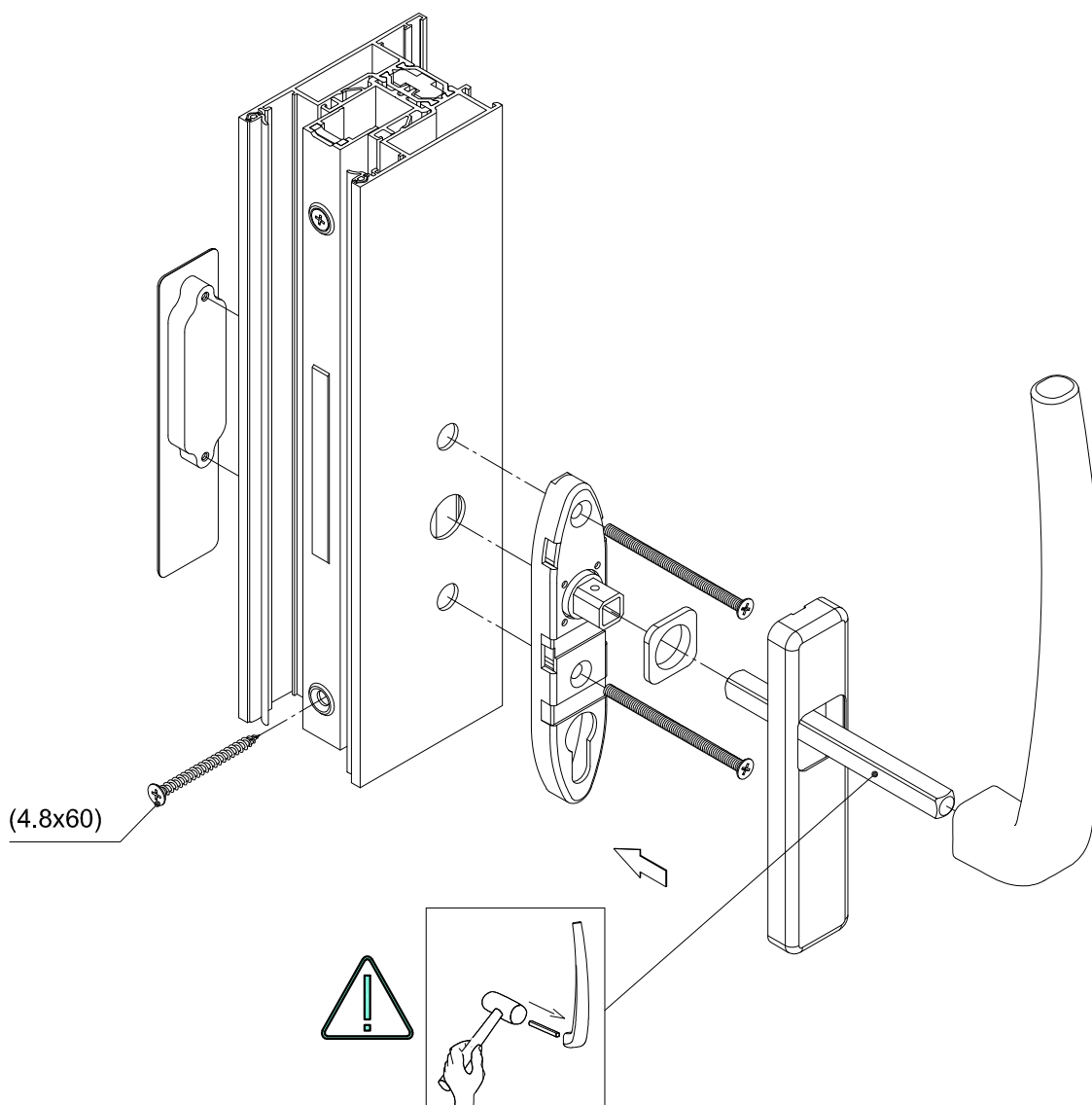
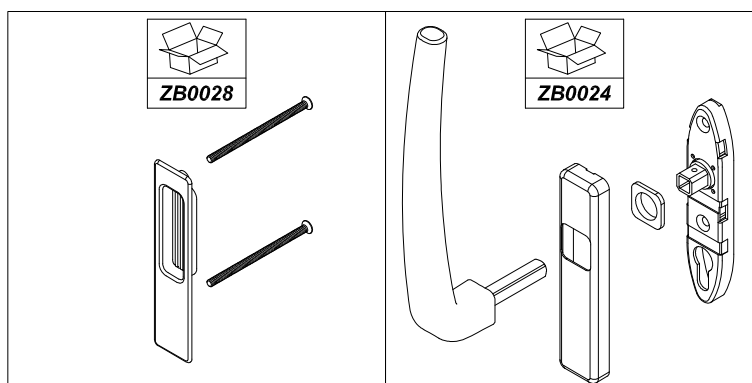
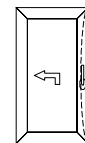



ASSEMBLAGGIO FERRAMENTA ANTA

INSTALLAZIONE MANIGLIA INTERNA STANDARD CON MEZZO CILINDRO ALZANTE-SCORREVOLE

3 / 5

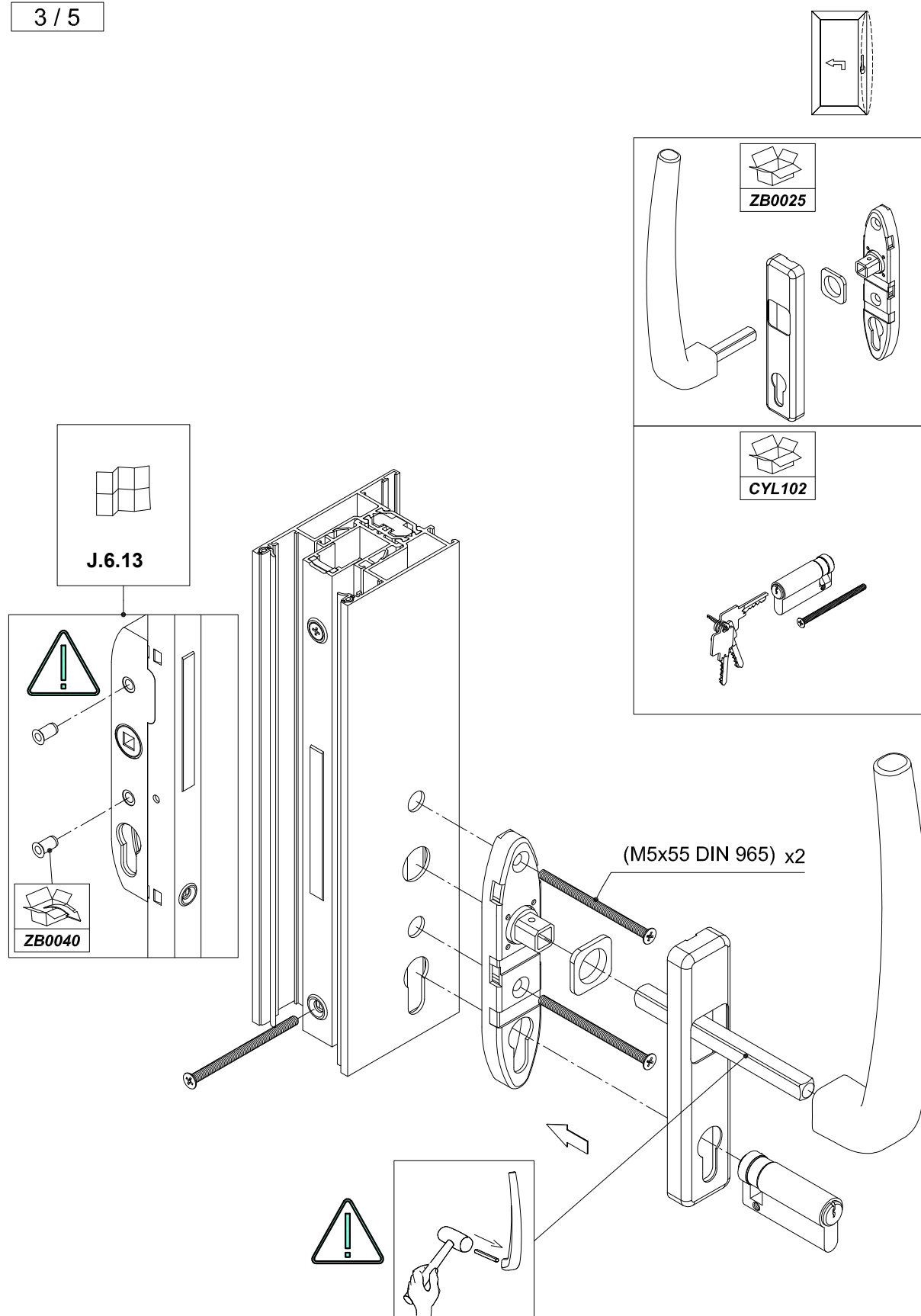

MANIGLIA INTERNA STANDARD CON MEZZO CILINDRO E VASCHETTA ALZANTE-SCORREVOLE

4 / 5

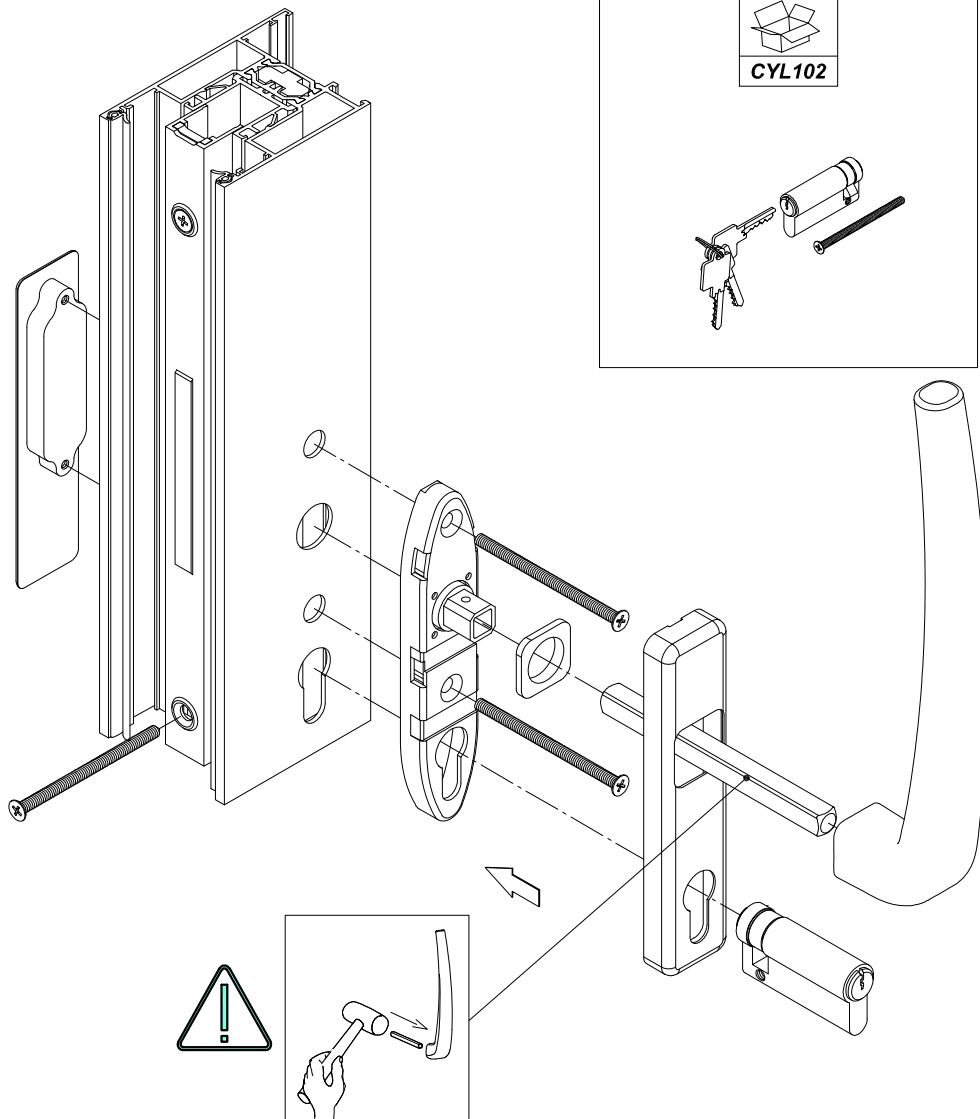
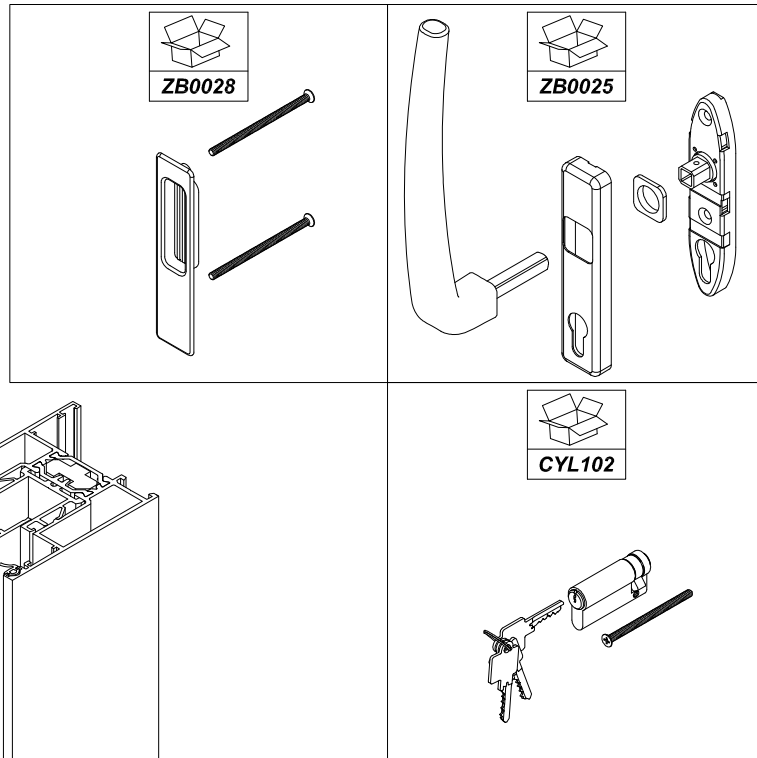
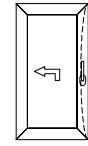



ASSEMBLAGGIO FERRAMENTA ANTA

INSTALLAZIONE MANIGLIA STANDARD SU DUE LATI CON CILINDRO ALZANTE-SCORREVOLE

5 / 5

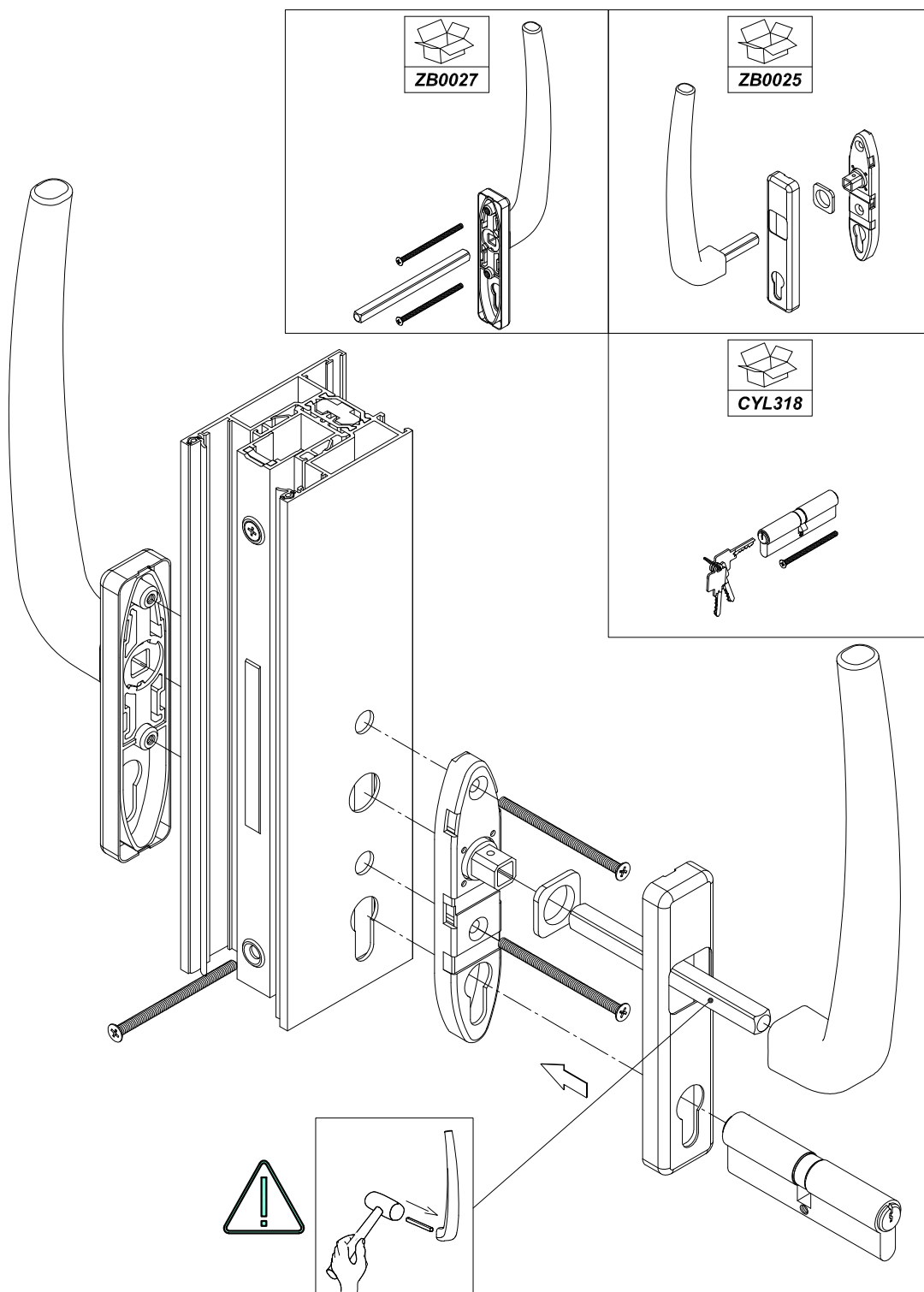
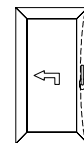

INSTALLAZIONE MANIGLIA INTERNA S-LINE HARMONY ALZANTE-SCORREVOLE

1 / 5

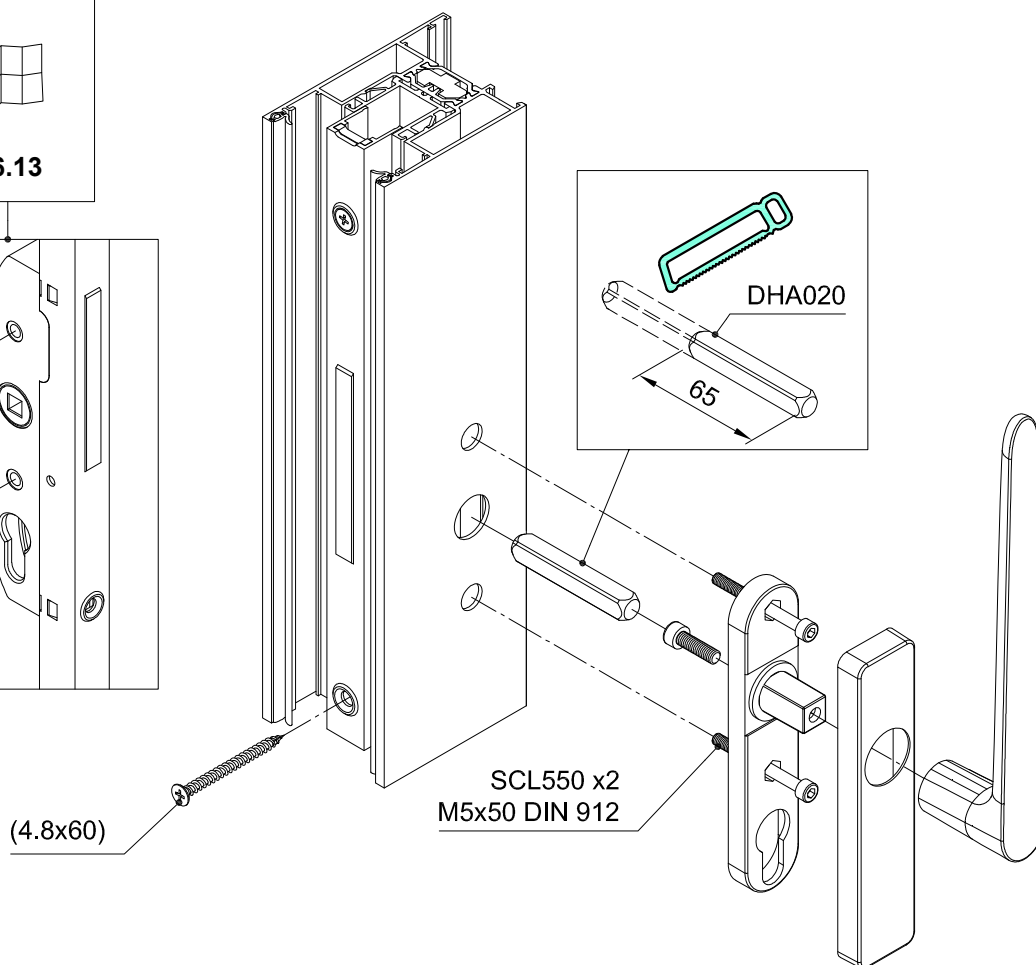
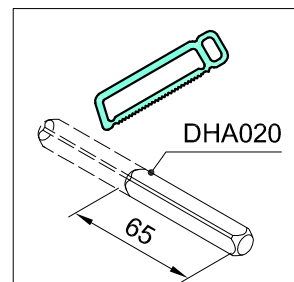
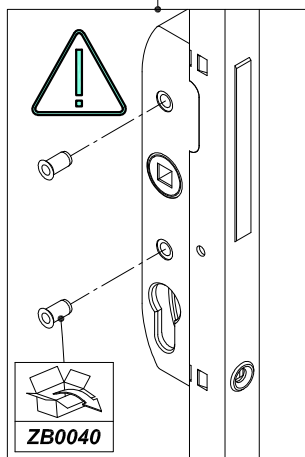
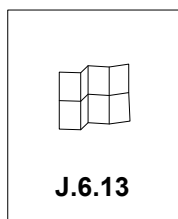
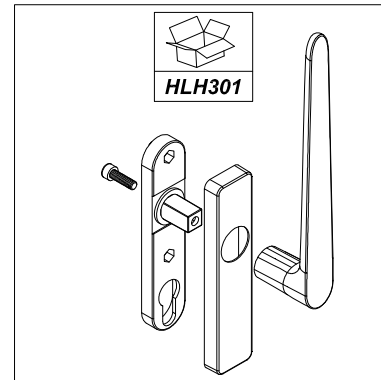
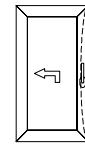



ASSEMBLAGGIO FERRAMENTA ANTA

MANIGLIA INTERNA S-LINE HARMONY E VASCHETTA ESTERNA ALZANTE-SCORREVOLE

2 / 5

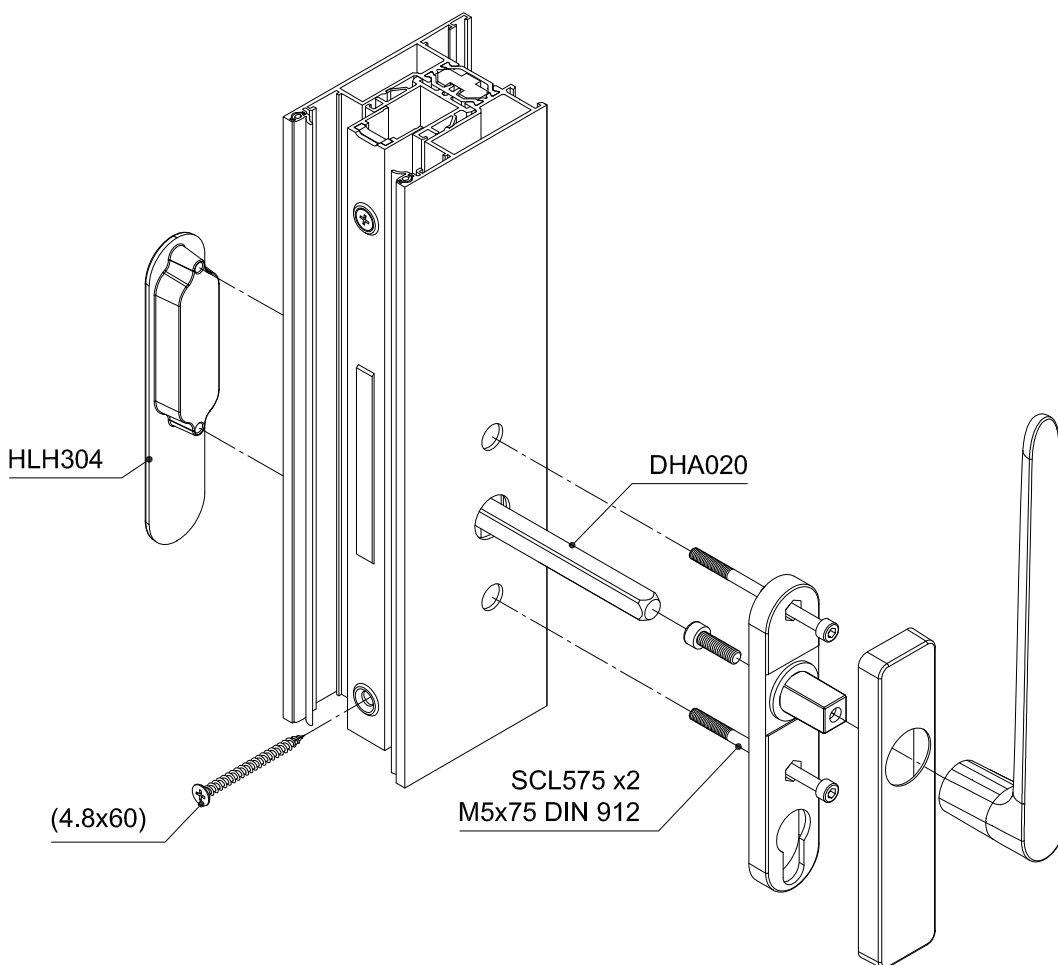
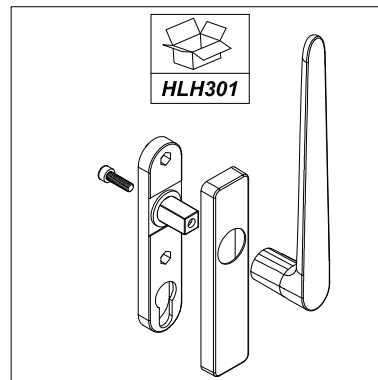
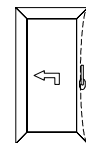

INSTALLAZIONE MANIGLIA INTERNA S-LINE HARMONY CON MEZZO CILINDRO ALZANTE-SCORREVOLE

3 / 5

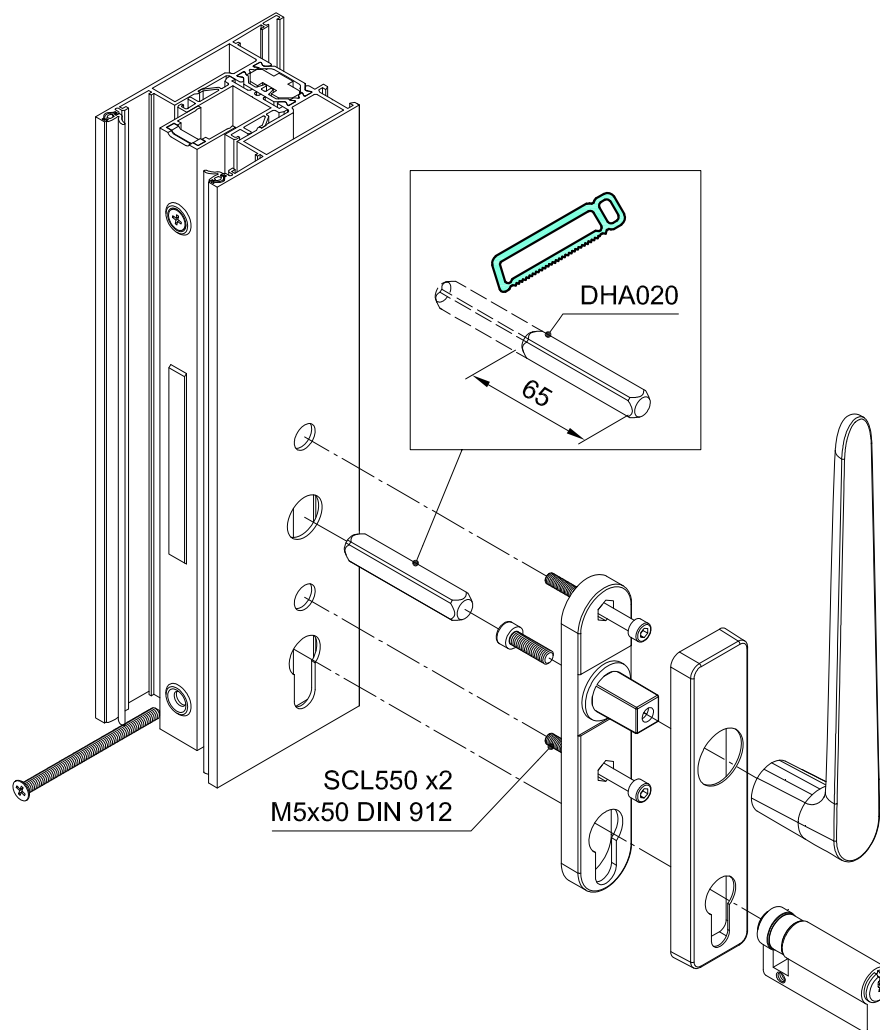
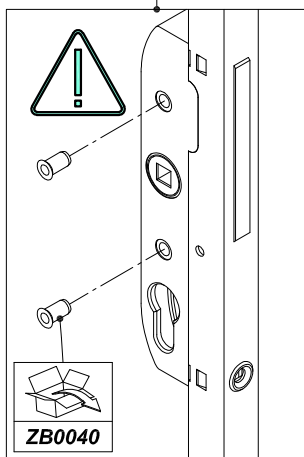
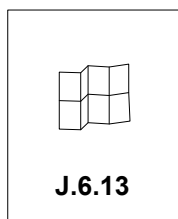
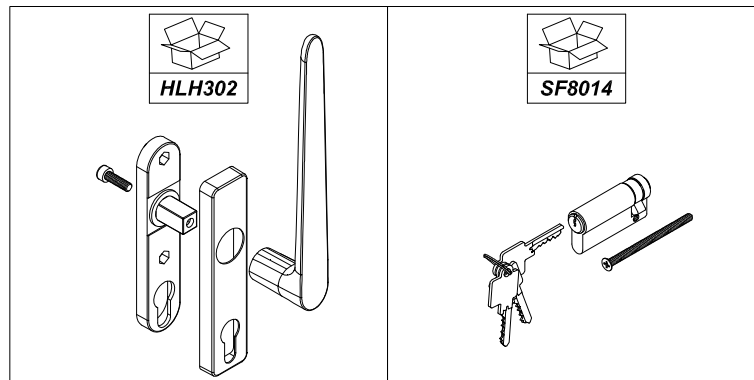
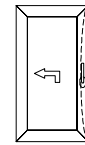



ASSEMBLAGGIO FERRAMENTA ANTA

MANIGLIA INTERNA S-LINE HARMONY CON MEZZO CILINDRO E VASCHETTA ALZANTE-SCORREVOLE

4 / 5

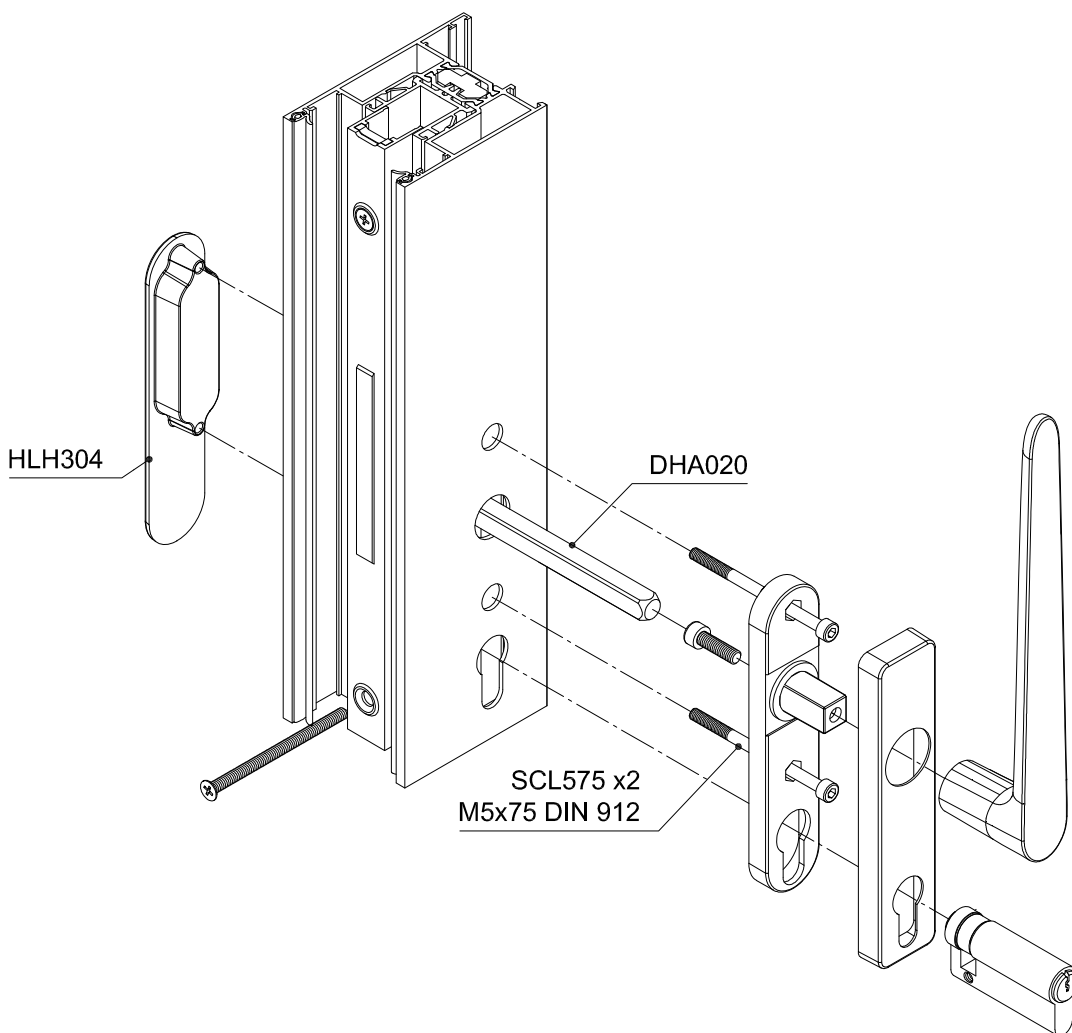
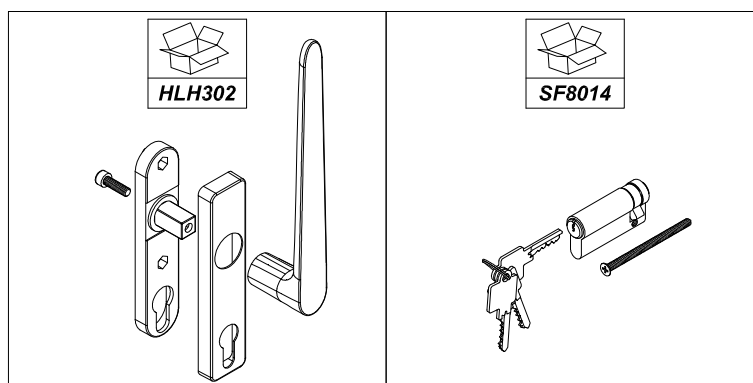
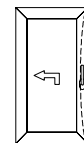

INSTALLAZIONE MANIGLIA S-LINE HARMONY SU DUE LATI CON CILINDRO ALZANTE-SCORREVOLE

5 / 5

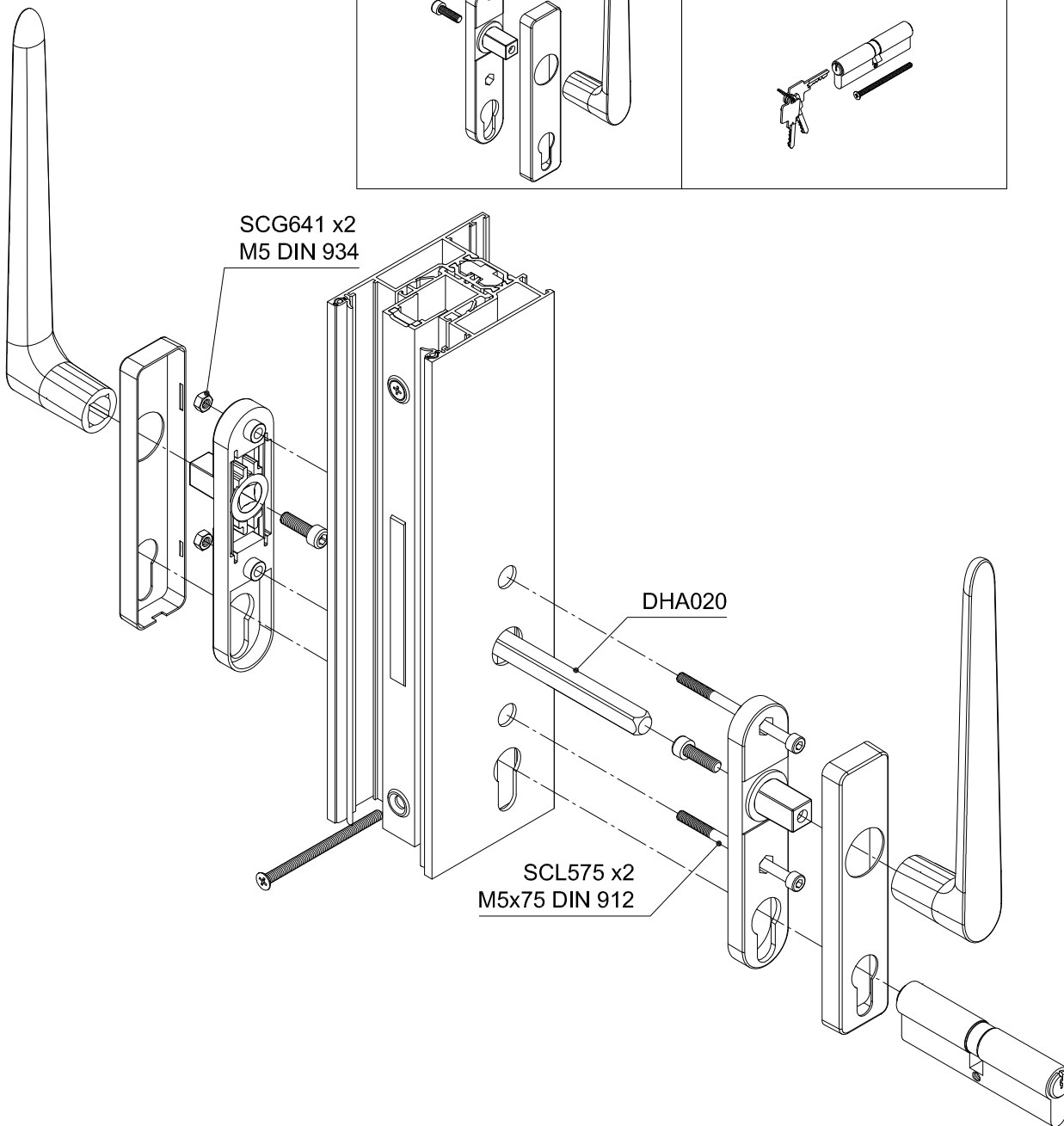
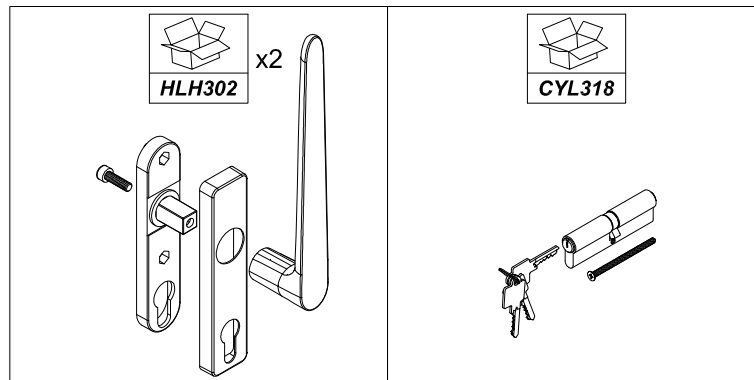
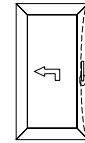



ASSEMBLAGGIO FERRAMENTA ANTA - RC2

FERRAMENTA ALZANTE-SCORREVOLE PANORAMICA

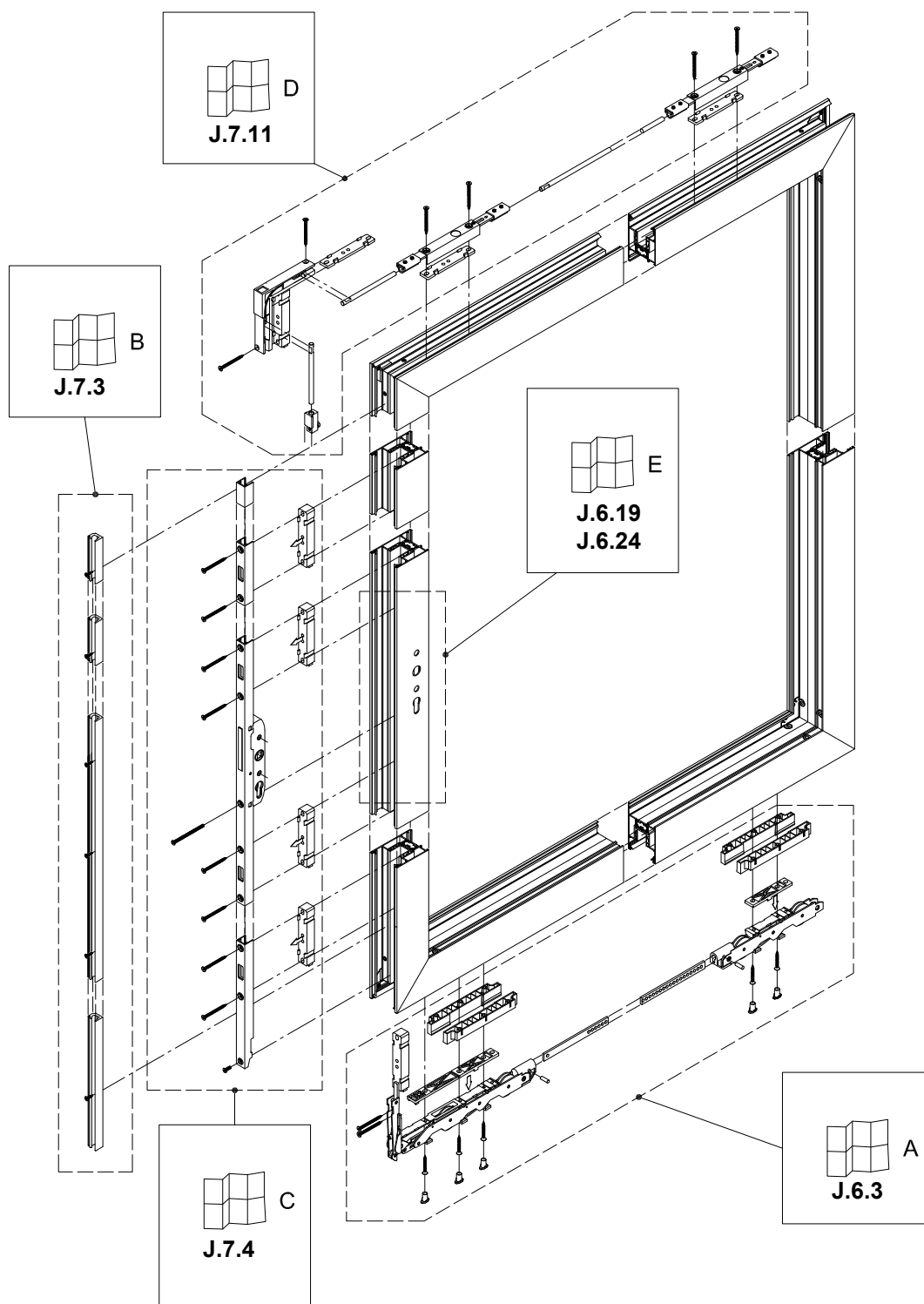
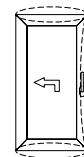

CONTENUTO

Assemblaggio ferramenta anta - RC2.....	J.7.1
Ferramenta alzante-scorrevole panoramica.....	J.7.1
Contenuto.....	J.7.2



Installazione ZB0033/ZB0034/ZB0035/ZB0036.....	J.7.4
Preparazione chiusura meccanismo alzante-scorrevole.....	J.7.5
Installazione ZB0033/ZB0034/ZB0035/ZB0036 - no maniglia esterna opzioni.....	J.7.6



Installazione chiusura meccanismo alzante-scorrevole.....	J.7.14
---	--------



ASSEMBLAGGIO FERRAMENTA ANTA - RC2

ASSEMBLAGGIO CO2206

1 / 15

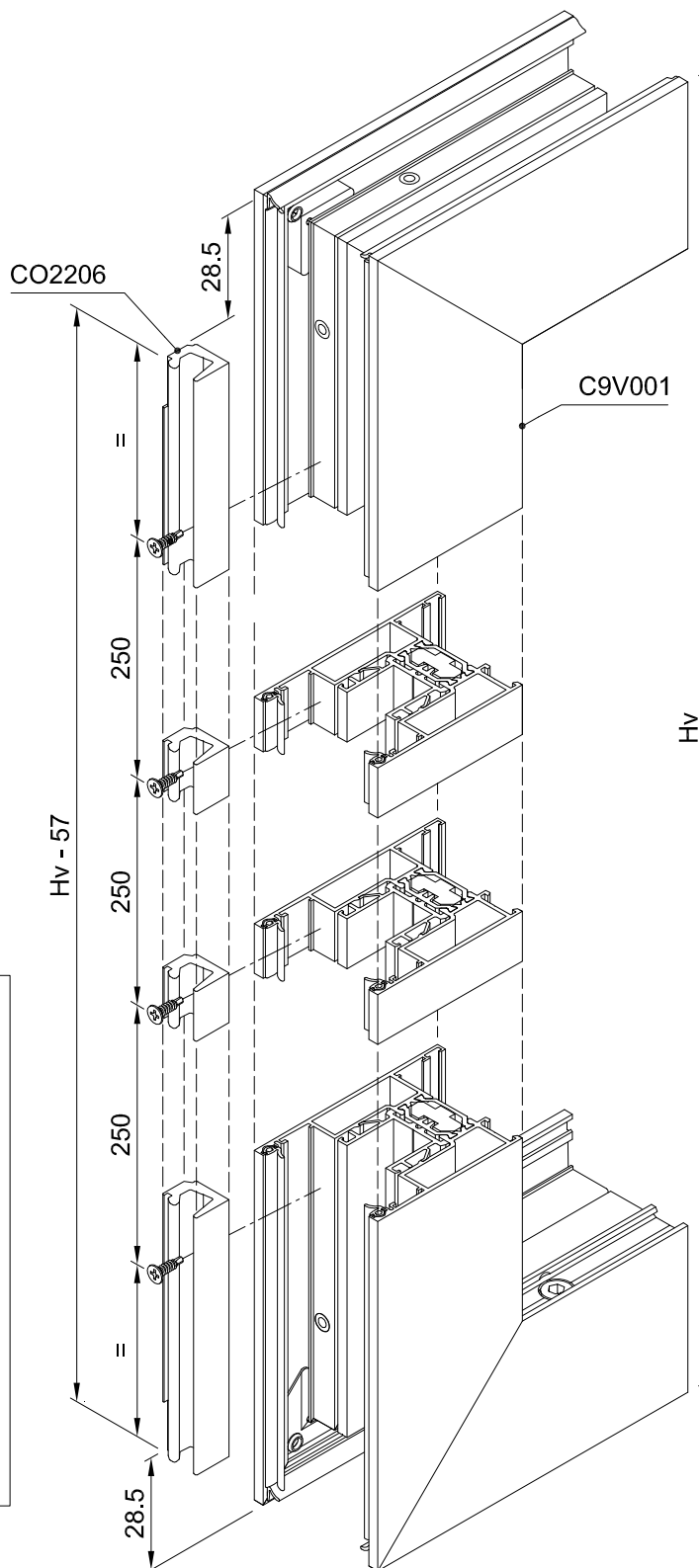
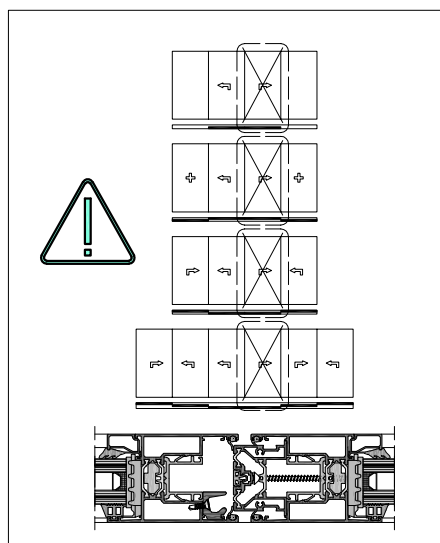
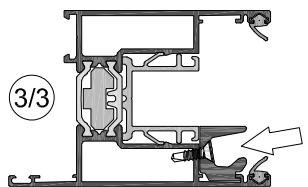
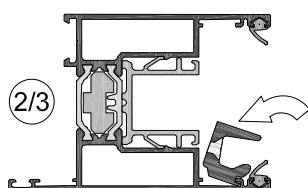
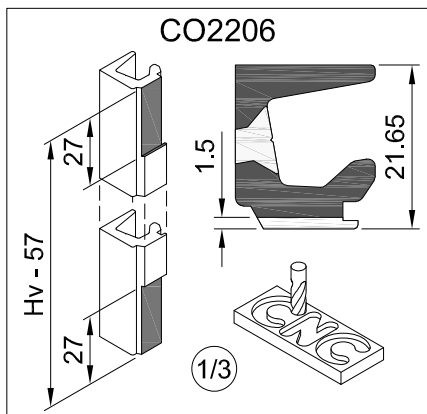
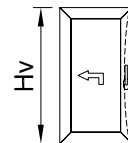
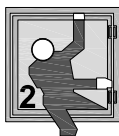

INSTALLAZIONE ZB0033/ZB0034/ZB0035/ZB0036

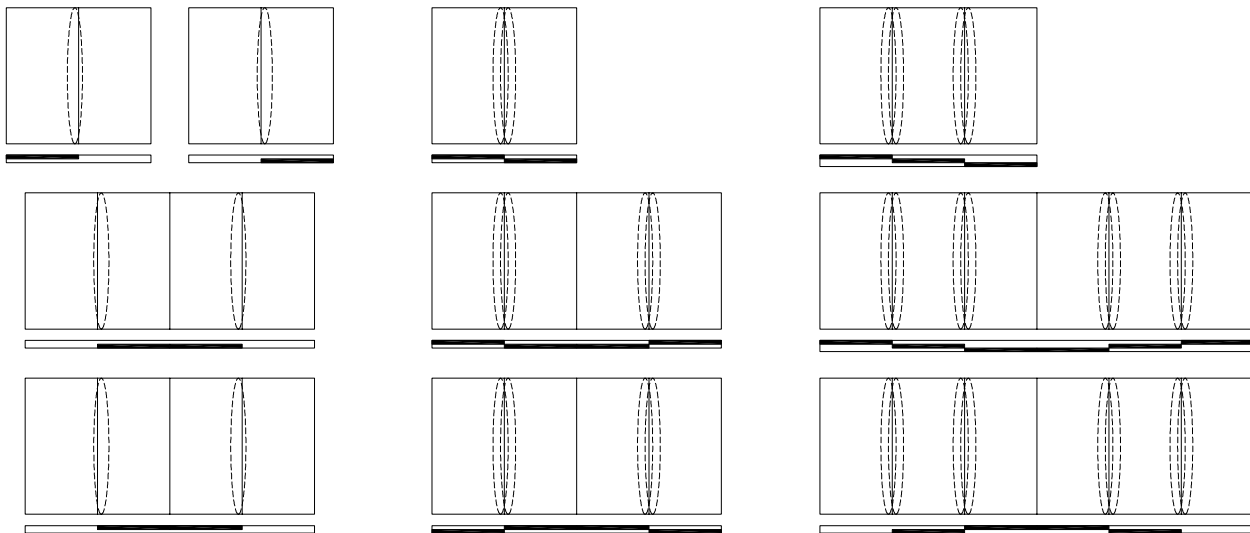
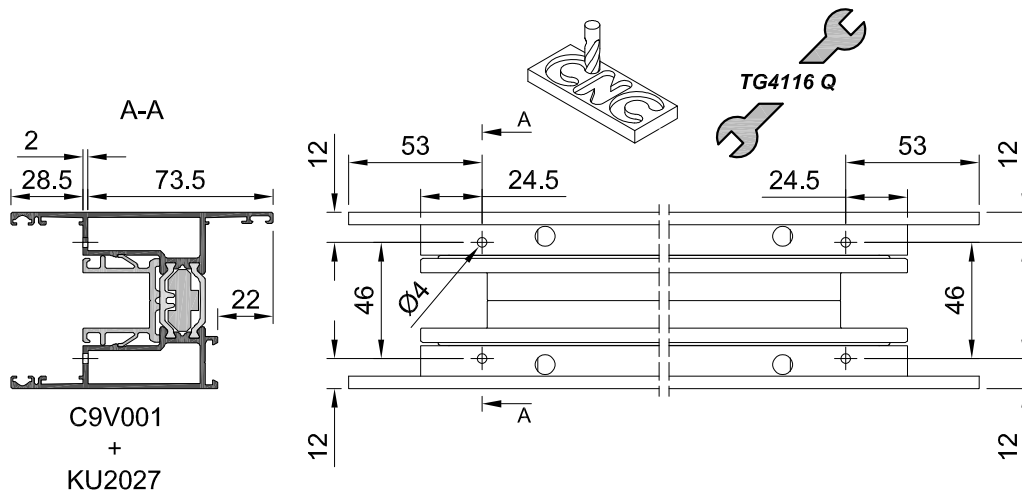
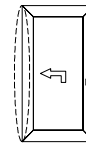



ASSEMBLAGGIO FERRAMENTA ANTA - RC2

PREPARAZIONE CHIUSURA MECCANISMO ALZANTE-SCORREVOLE

3 / 15

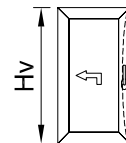
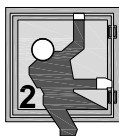

	Hv
ZB0034	1904 - 2203
ZB0035	2204 - 2503
ZB0036	2504 - 2803
ZB0035*	2804 - 3103
ZB0036*	3104 - 3403
ZB0033	1303 - 1903

* + ZB0046

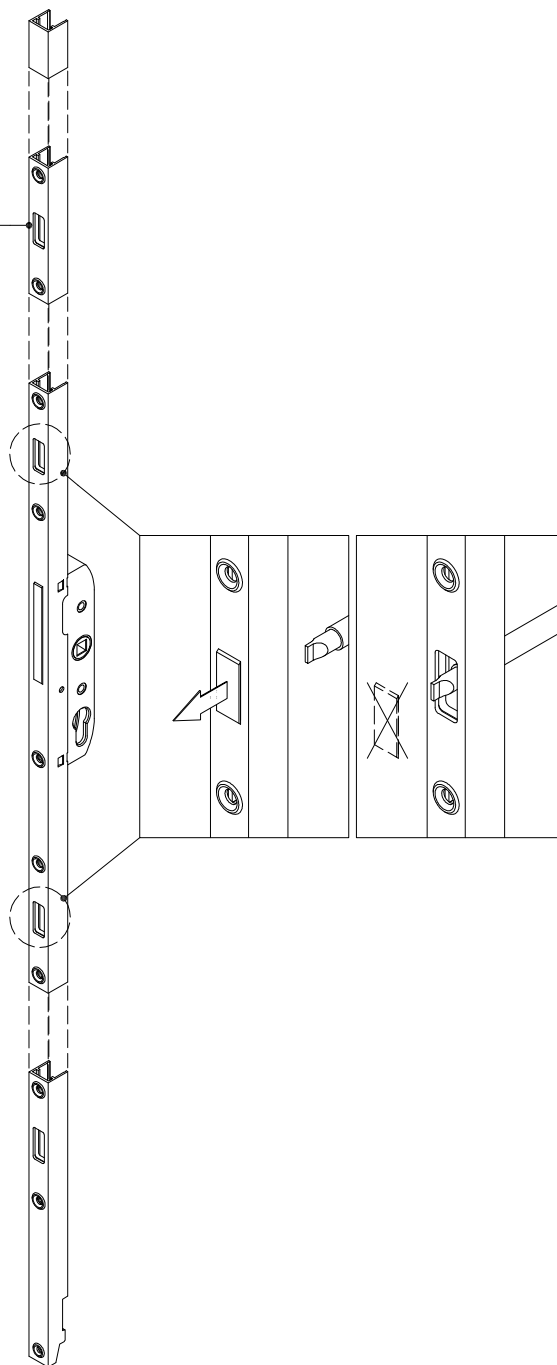

INSTALLAZIONE ZB0033/ZB0034/ZB0035/ZB0036 - NO MANIGLIA ESTERNA OPTIONAL

4 / 15

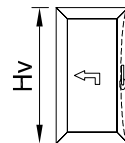
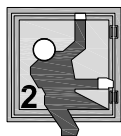

	Hv
ZB0034	1904 - 2203
ZB0035	2204 - 2503
ZB0036	2504 - 2803
ZB0035*	2804 - 3103
ZB0036*	3104 - 3403
ZB0033	1303 - 1903

* + ZB0046

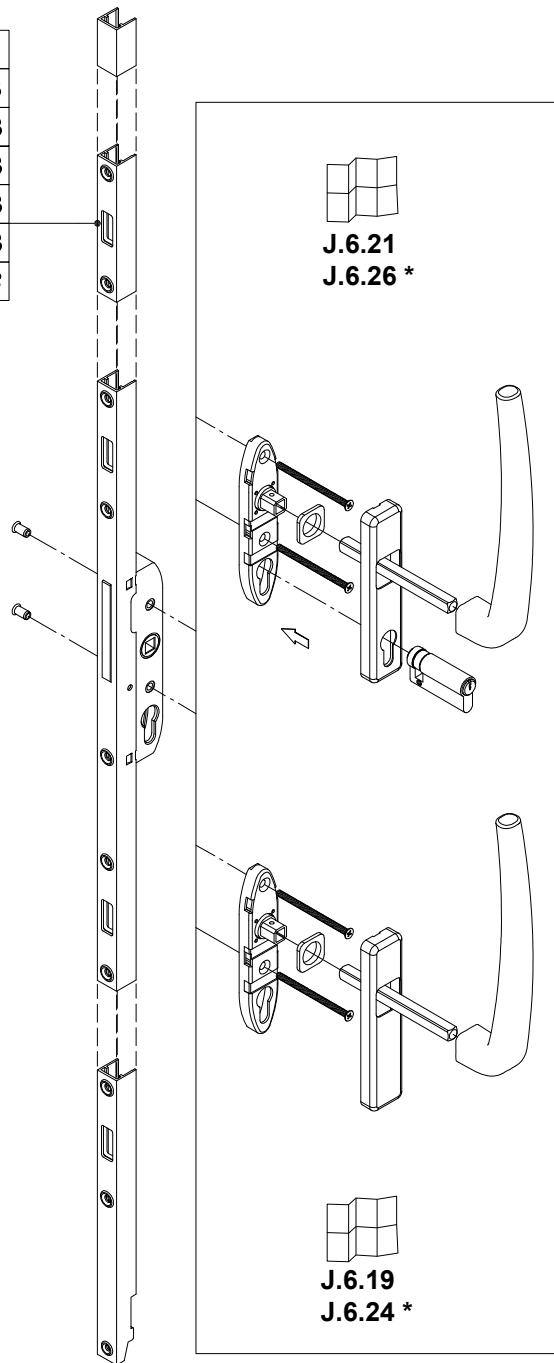
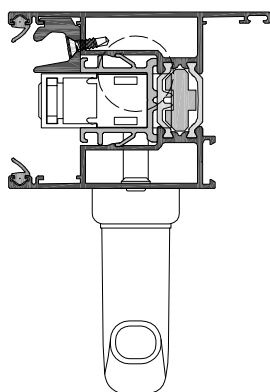
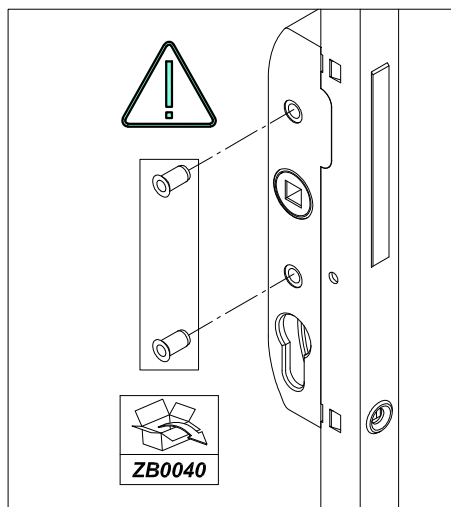

* - S-LINE



ASSEMBLAGGIO FERRAMENTA ANTA - RC2

ASSEMBLAGGIO ZB0053/ZB0054

1 / 5

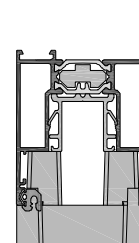
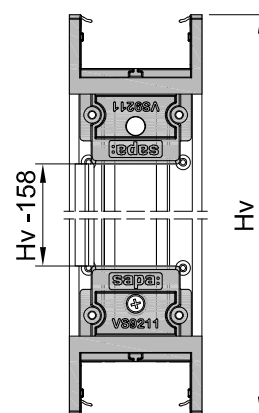
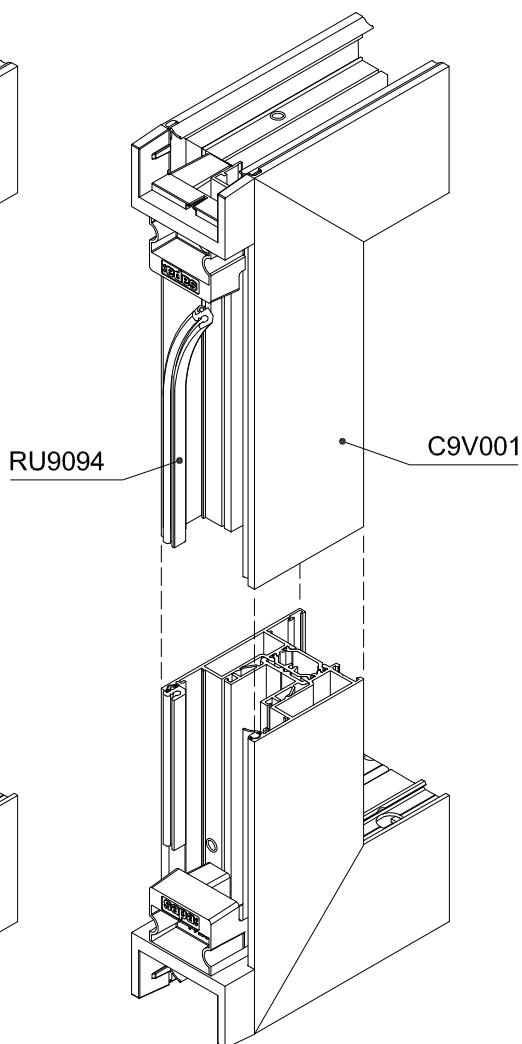
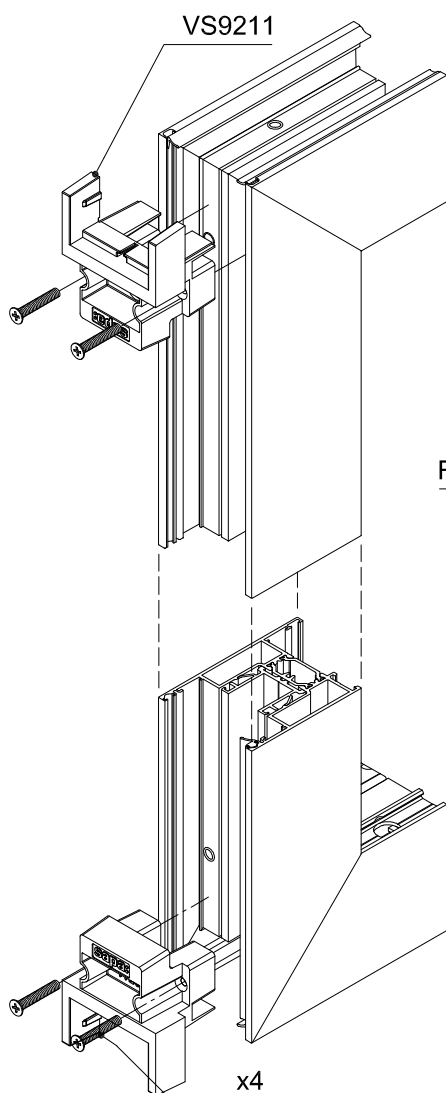
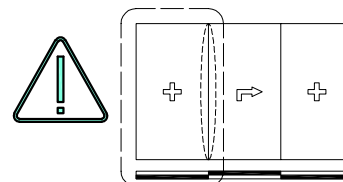
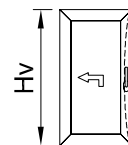
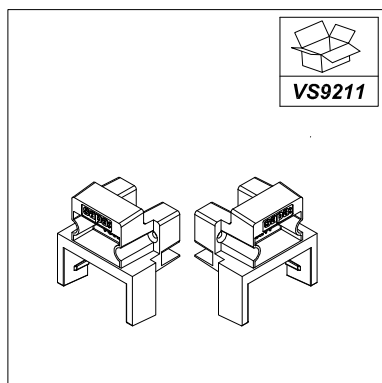

C160-ASS-2257L

INSTALLAZIONE ZB0046

6 / 15

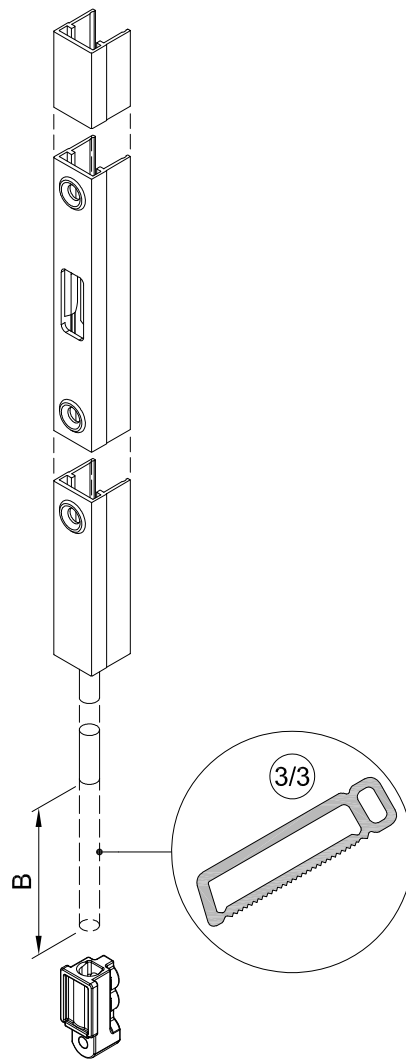
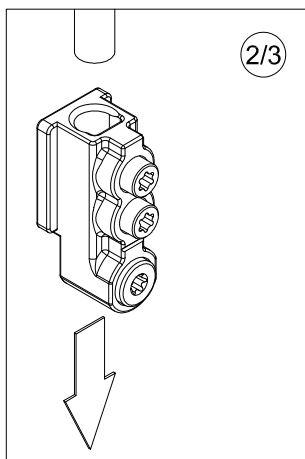
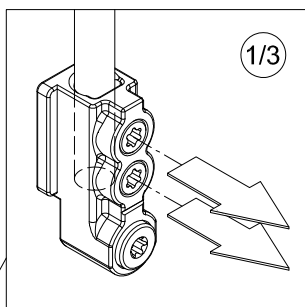
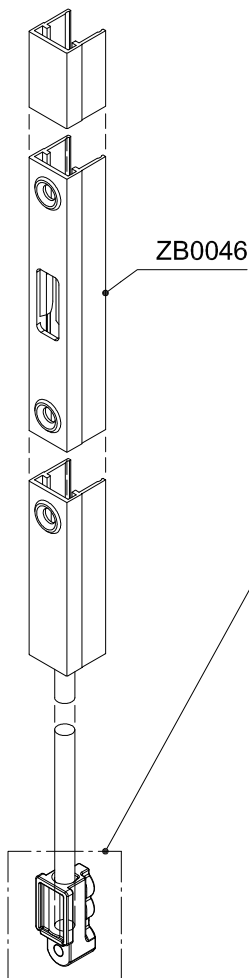
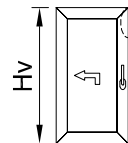
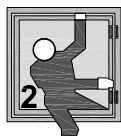

	Hv	B
ZB0035*	2804 - 3103	3077 - Hv
ZB0036*	3104 - 3403	3377 - Hv

* + ZB0046



ASSEMBLAGGIO FERRAMENTA ANTA - RC2

ASSEMBLAGGIO ZB0035/ZB0036 CON ZB0046

7 / 15

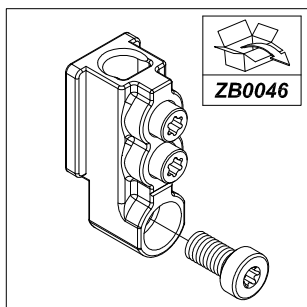
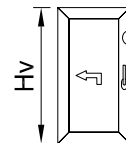
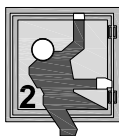

ZB0046

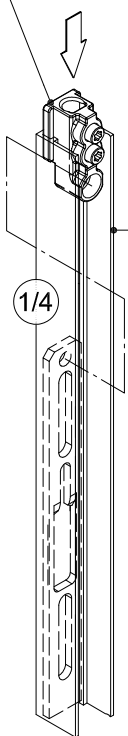

	Hv
ZB0035*	2804 - 3103
ZB0036*	3104 - 3403

* + ZB0046

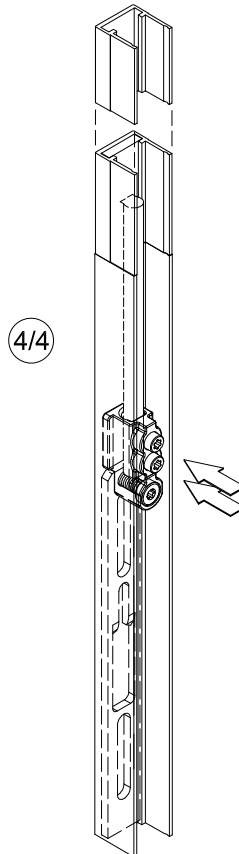
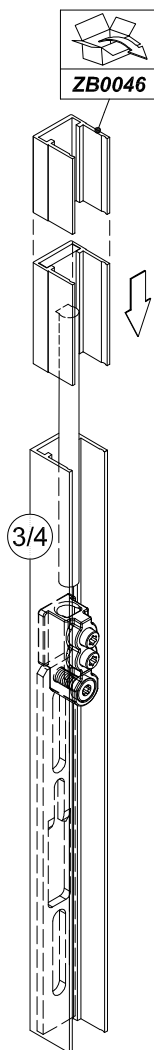
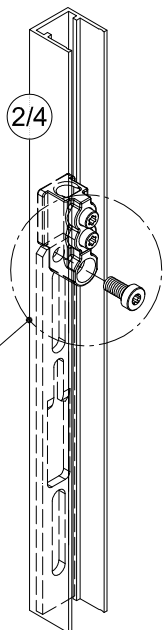
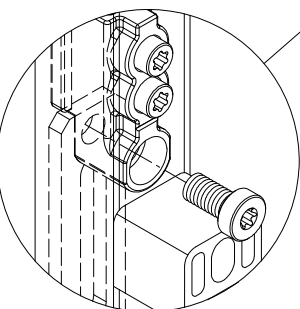

ASSEMBLAGGIO ZB0035/ZB0036/ZB0046 CON ZB0048 E ZB0049/ZB0050

8 / 15

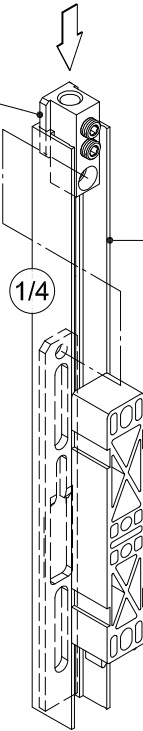
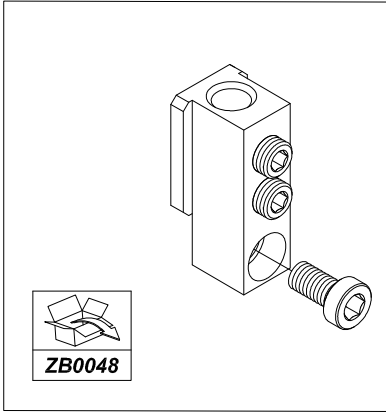
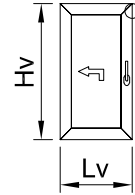

	Hv
ZB0034	1904 - 2203
ZB0035	2204 - 2503
ZB0036	2504 - 2803
ZB0035*	2804 - 3103
ZB0036*	3104 - 3403
ZB0033	1303 - 1903

* + ZB0046

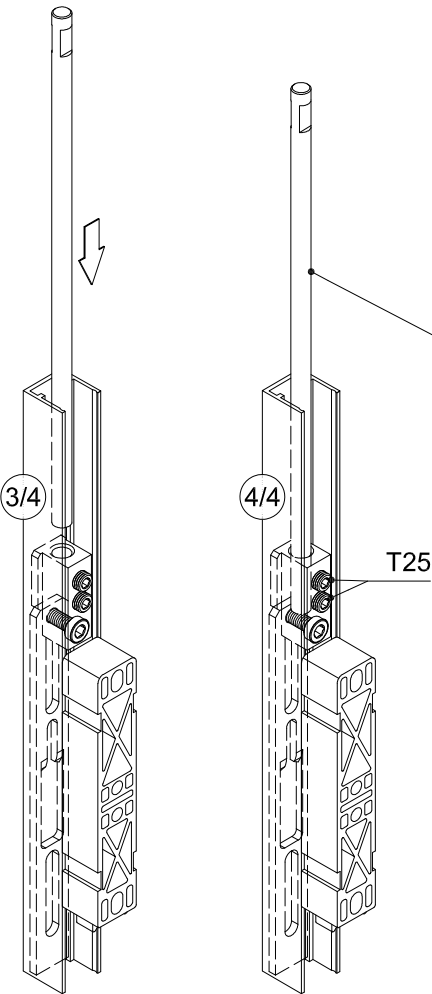
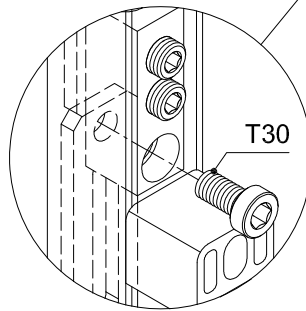
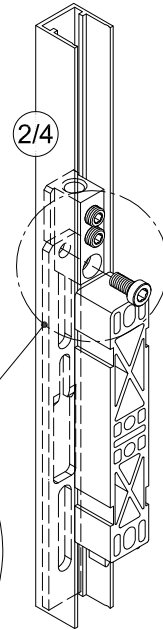

	Hv	C
ZB0034	1904 - 2203	Hv - 1803
ZB0035	2204 - 2503	Hv - 2103
ZB0036	2504 - 2803	Hv - 2403
ZB0035*	2804 - 3103	215 ??
ZB0036*	3104 - 3403	
ZB0033	1303 - 1903	Hv - 1503

* + ZB0046

$Hv + Lv \leq 5258$	ZB0049 (a)
$Hv + Lv > 5258$	ZB0050 (a)

ZB0049/ZB0050 (b)



ASSEMBLAGGIO FERRAMENTA ANTA - RC2

ASSEMBLAGGIO ZB0048 CON ZB0049/ZB0050

9 / 15

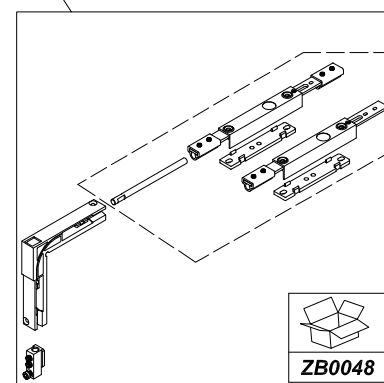
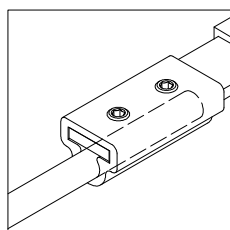
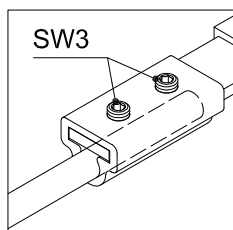
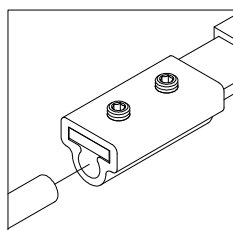
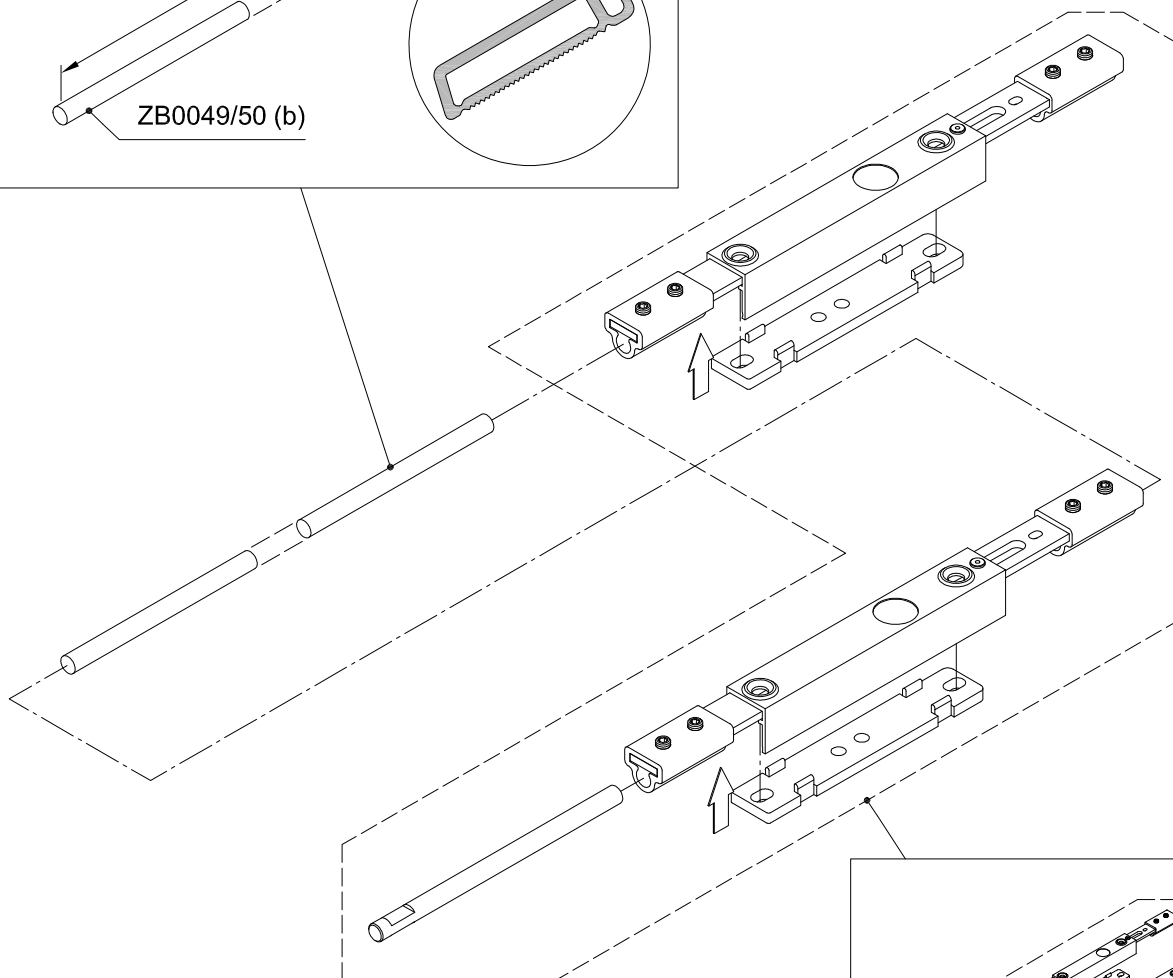
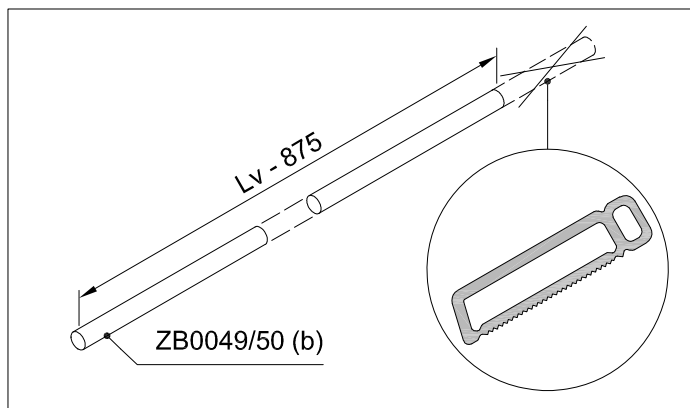
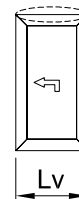
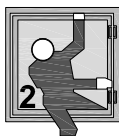

C160-ASS-2162L

ASSEMBLAGGIO ZB0035/ZB0036/ZB0046 CON ZB0048

10 / 15

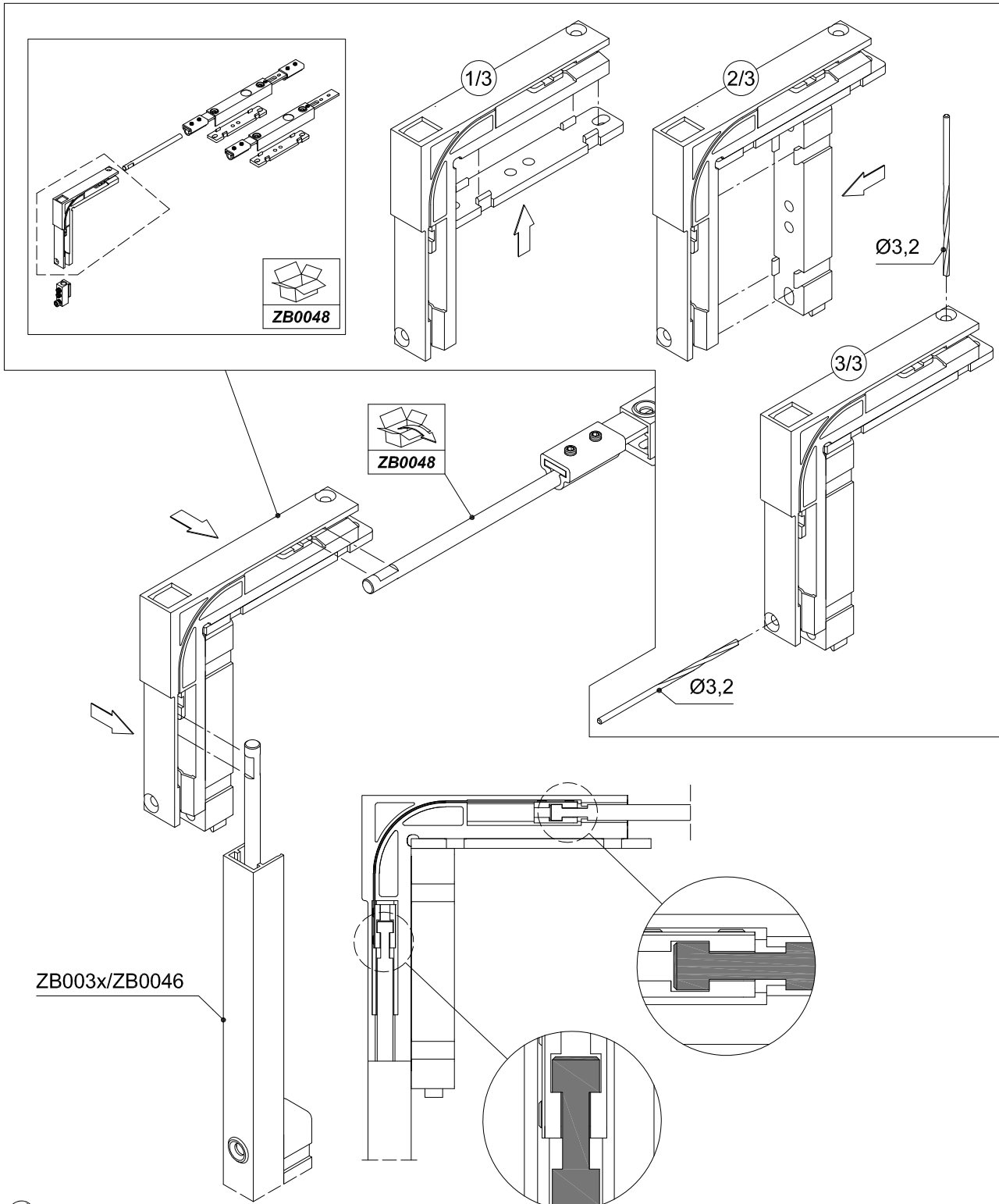
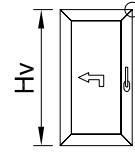

C160-ASS-2163L



ASSEMBLAGGIO FERRAMENTA ANTA - RC2

INSTALLAZIONE CHIUSURA MECCANISMO ALZANTE-SCORREVOLE

11 / 15

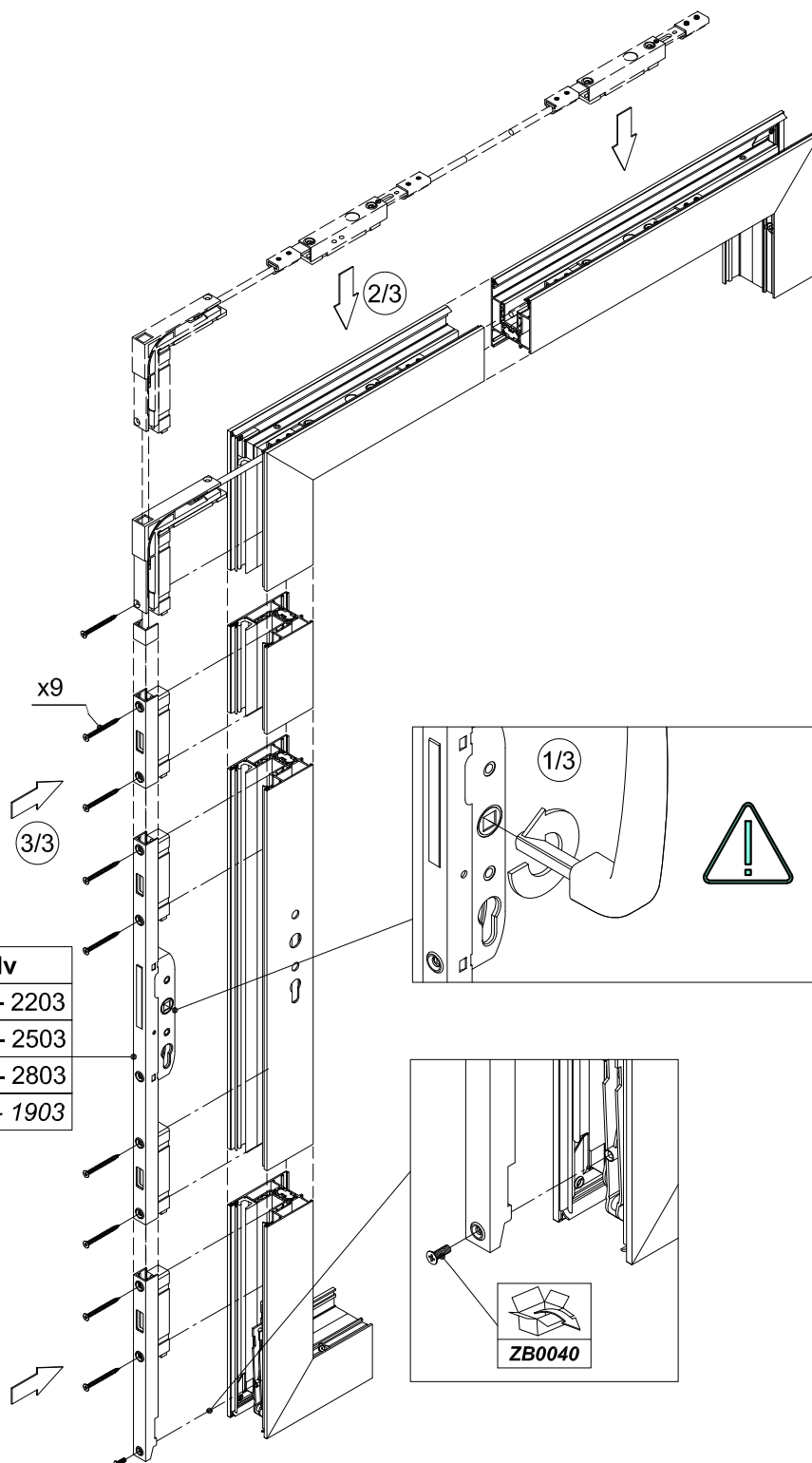
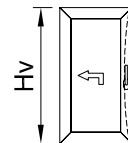
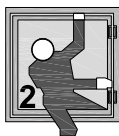

	Hv
ZB0034	1904 - 2203
ZB0035	2204 - 2503
ZB0036	2504 - 2803
ZB0033	1303 - 1903

* + ZB0046

INSTALLAZIONE CHIUSURA MECCANISMO ALZANTE-SCORREVOLE

12 / 15

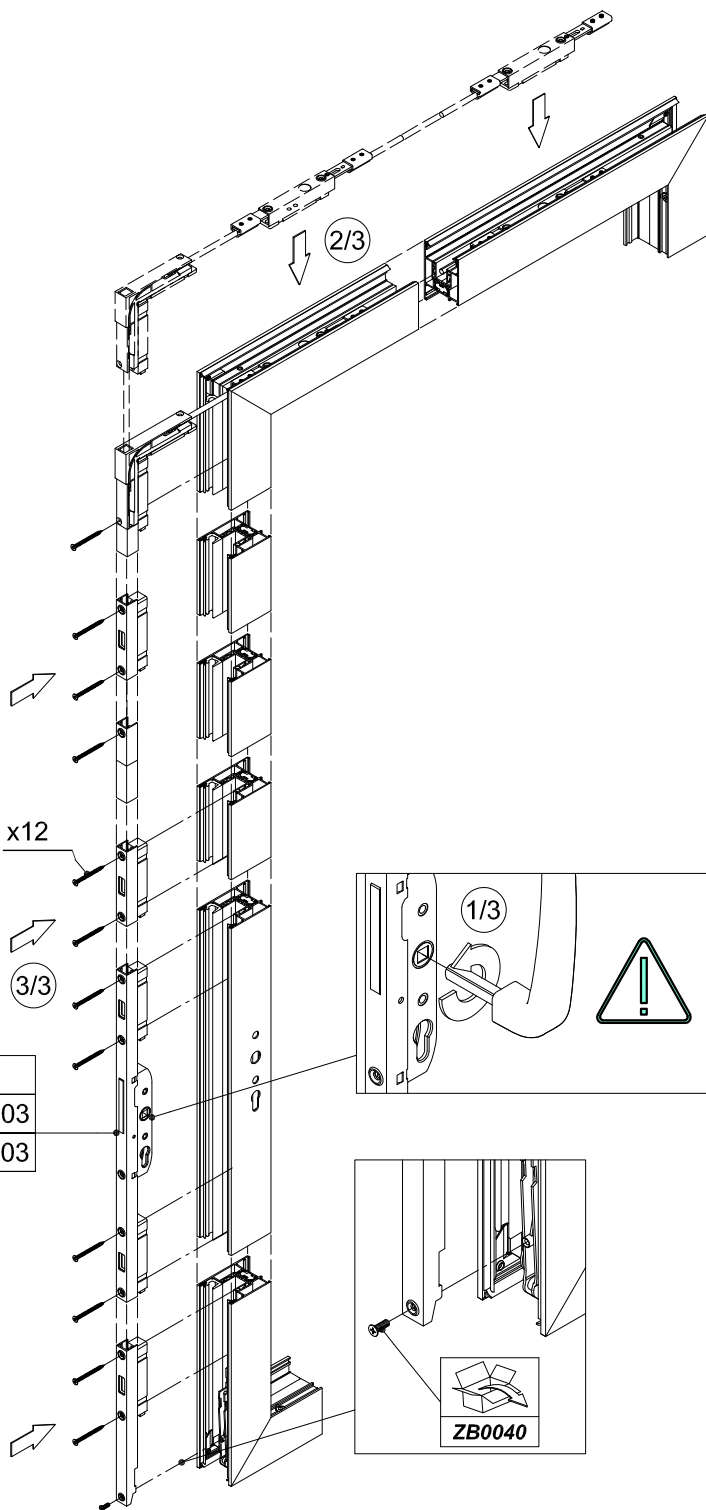
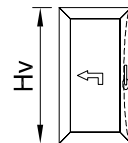
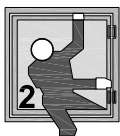

	Hv
ZB0035*	2804 - 3103
ZB0036*	3104 - 3403

* + ZB0046



ASSEMBLAGGIO FERRAMENTA ANTA - RC2

INSTALLAZIONE CHIUSURA MECCANISMO ALZANTE-SCORREVOLE - ANTA PASSIVA SCHEMA 4 ANTE

13 / 15

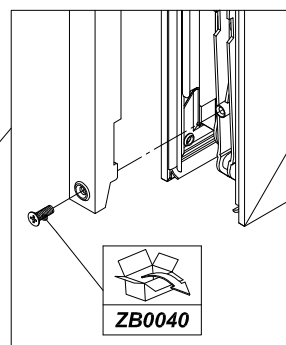
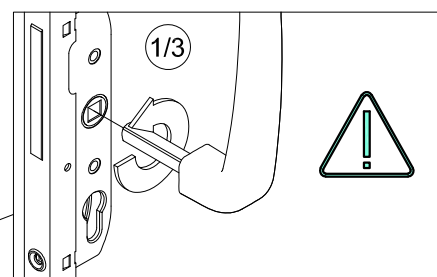
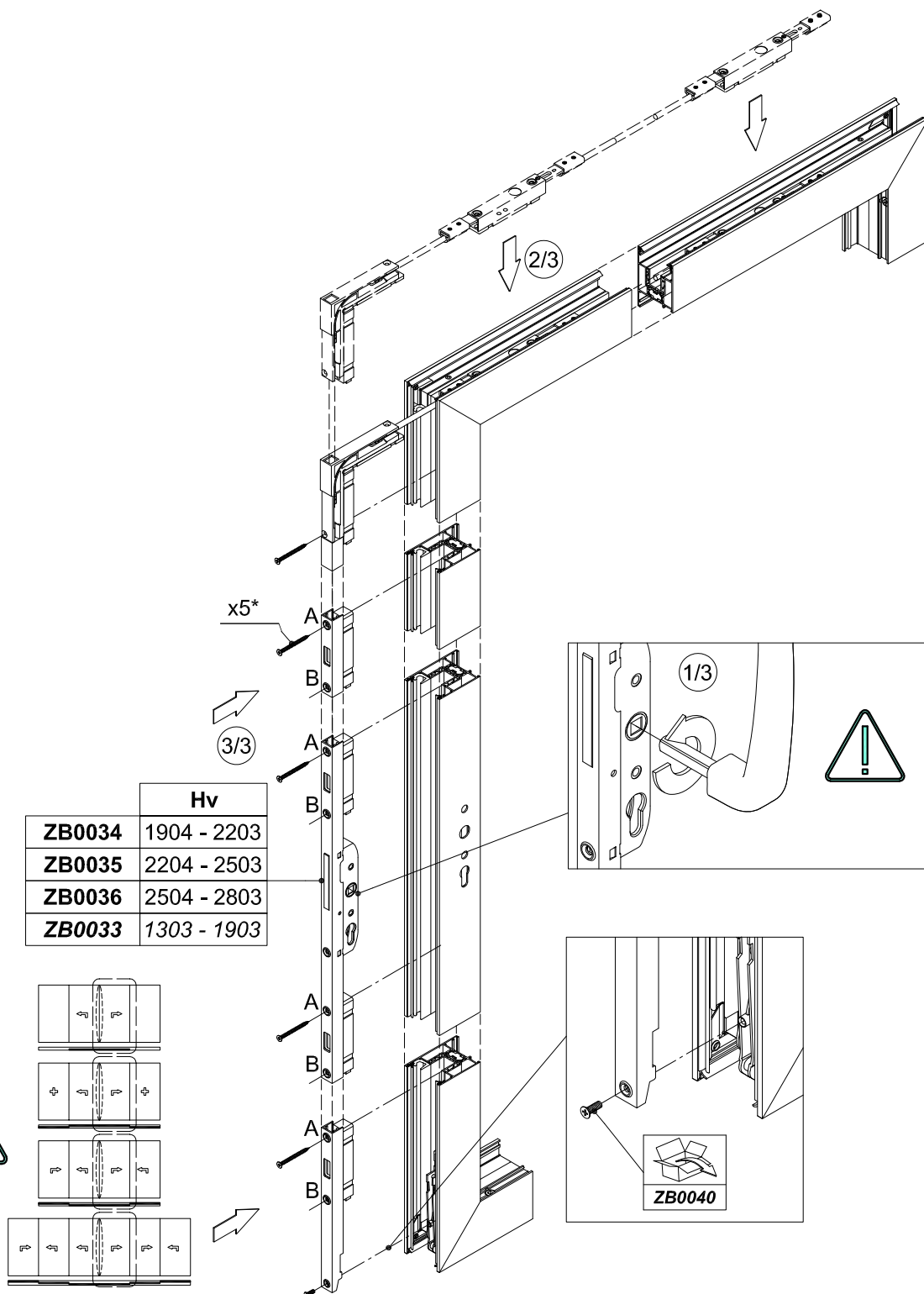
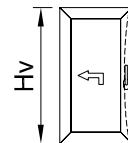
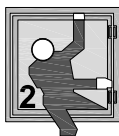

INSTALLAZIONE CHIUSURA MECCANISMO ALZANTE-SCORREVOLE - ANTA PASSIVA SCHEMA 4 ANTE

14 / 15

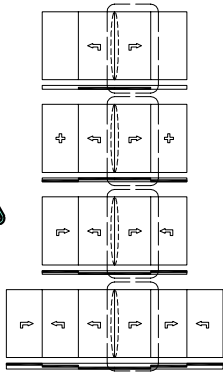
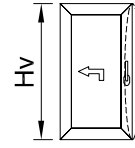

	Hv
ZB0035*	2804 - 3103
ZB0036*	3104 - 3403

* + ZB0046

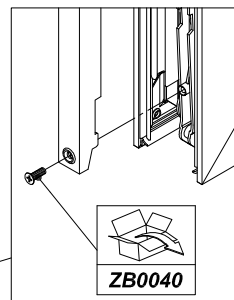
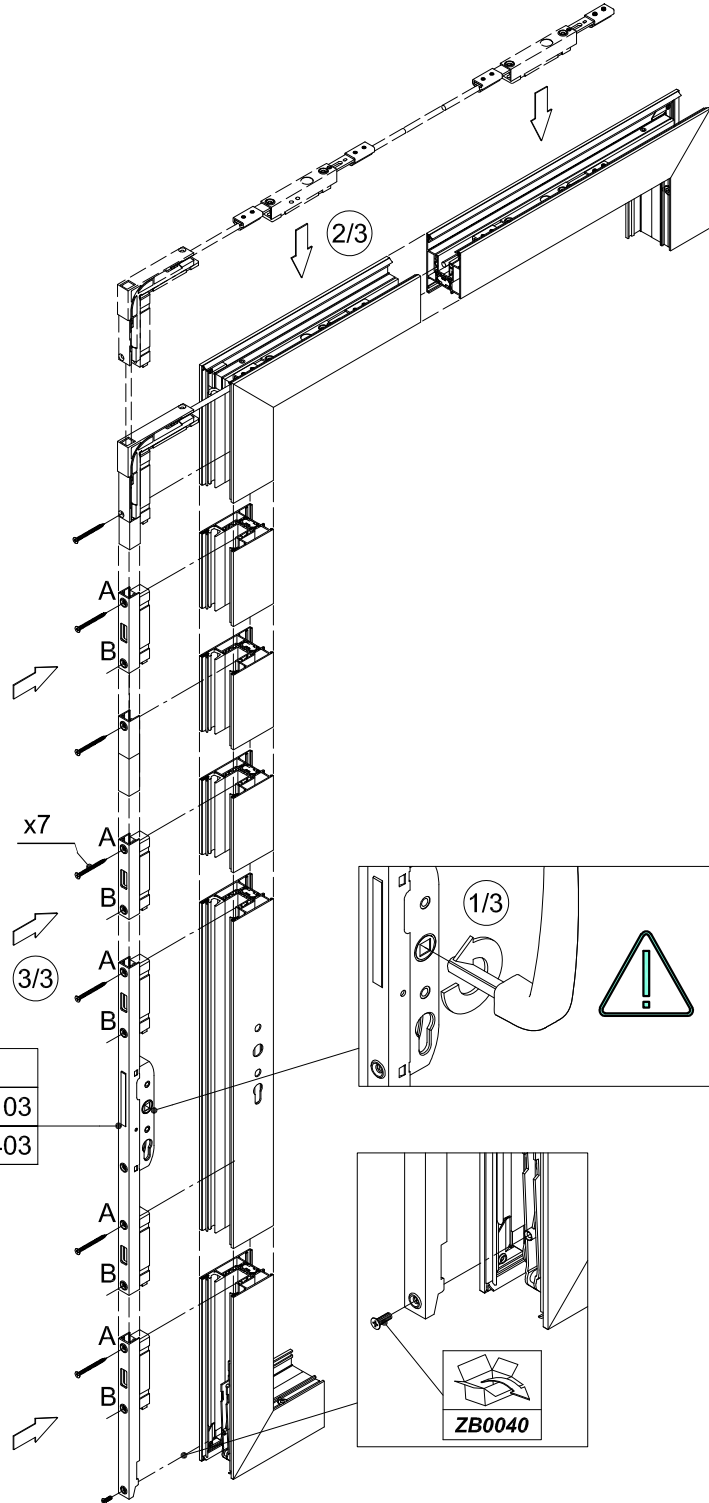



ASSEMBLAGGIO FERRAMENTA ANTA - RC2

INSTALLAZIONE CHIUSURA MECCANISMO ALZANTE-SCORREVOLE ZB0048

15 / 15

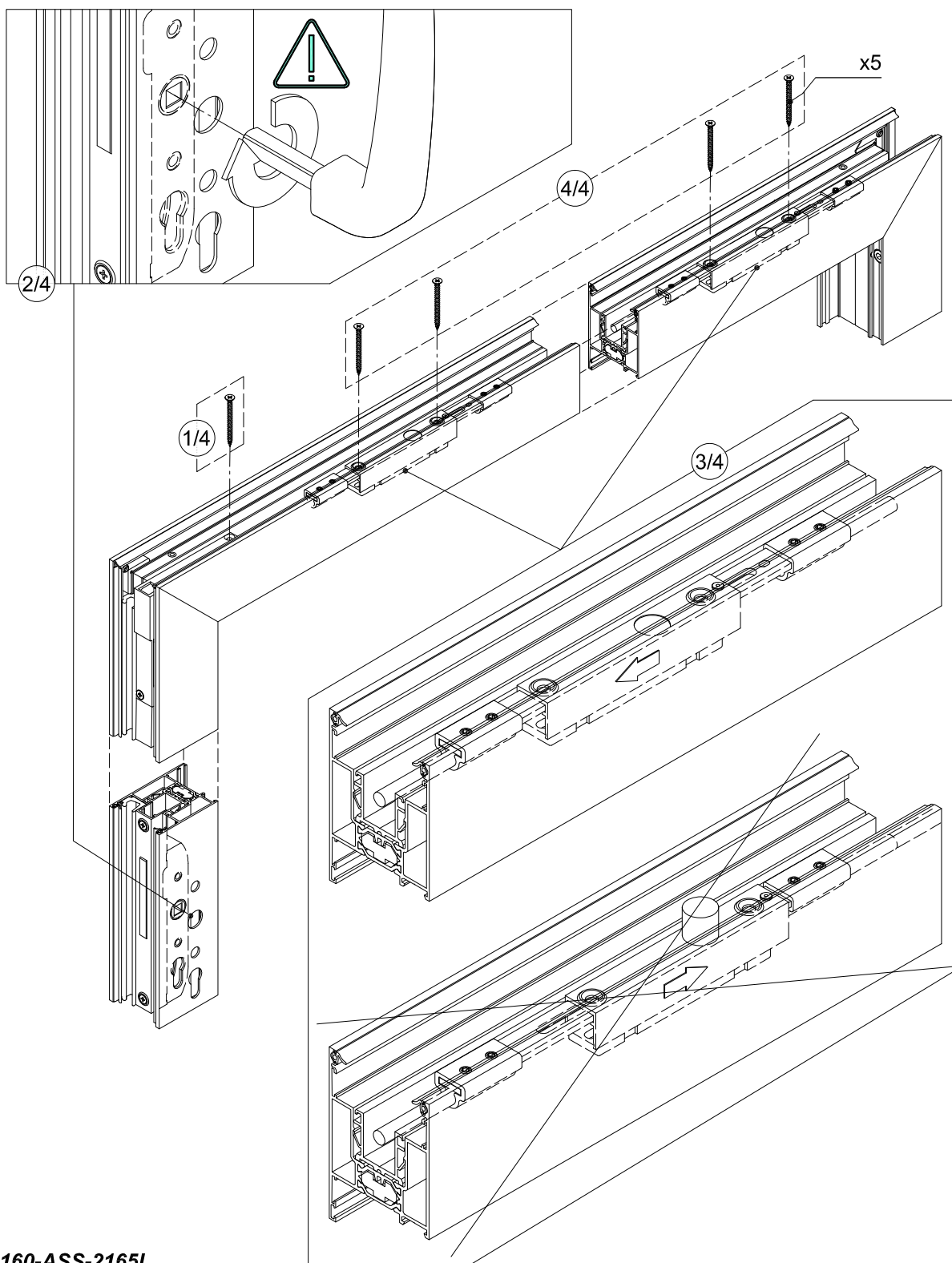
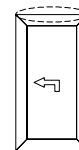
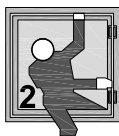

 C160-ASS-2165L



FERRAMENTA & DISEGNI ASSEMBLAGGIO

ASSEMBLAGGIO FERRAMENTA ANTA - RC2



RINFORZO ANTA - OPTIONAL

CONTENUTO

Rinforzo anta - optional.....	J.8.1
Contenuto.....	J.8.1
Installazione blocco supporto VS5132 e RU9094.....	J.8.2
Installazione C9C001.....	J.8.3
Lato ferramenta alzante-scorrevole - installazione RU9094.....	J.8.4
Lato ferramenta alzante-scorrevole - preparazione C9C001.....	J.8.5
Lato ferramenta alzante-scorrevole - installazione C9C001.....	J.8.6

INSTALLAZIONE BLOCCO SUPPORTO VS5132 E RU9094

1 / 2

-SHI-
-SI-
I

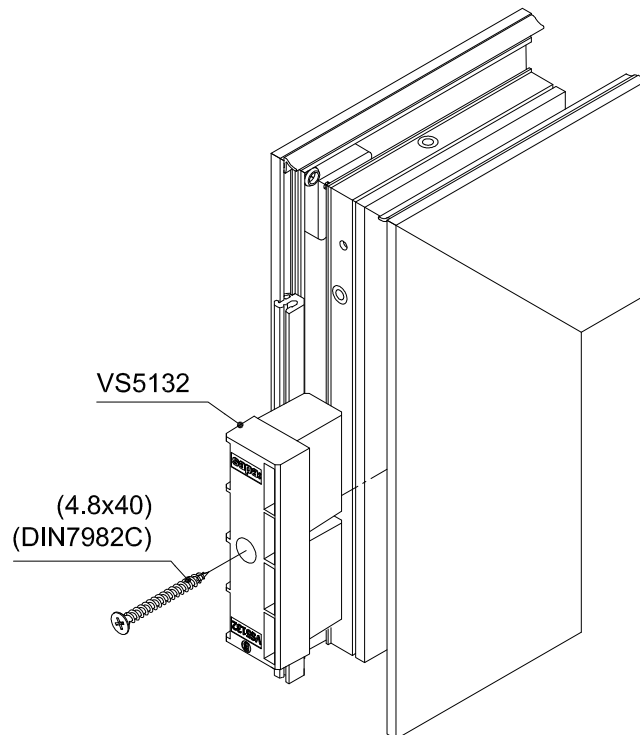
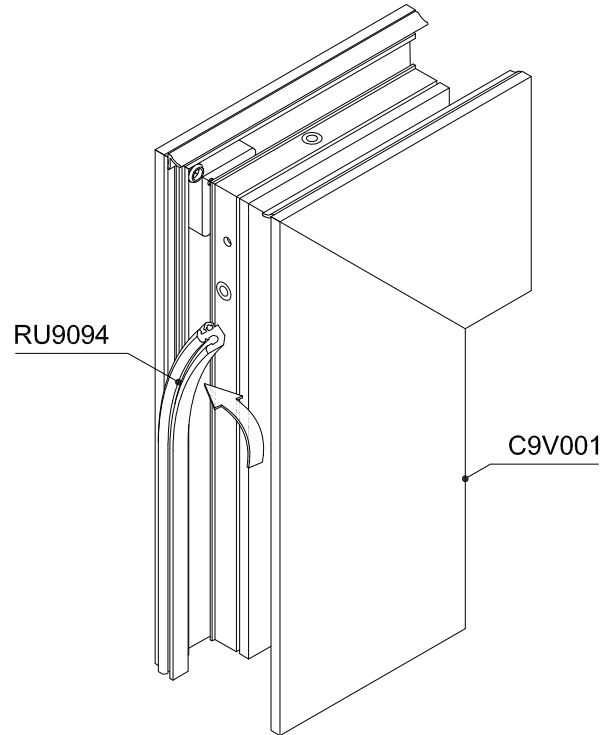
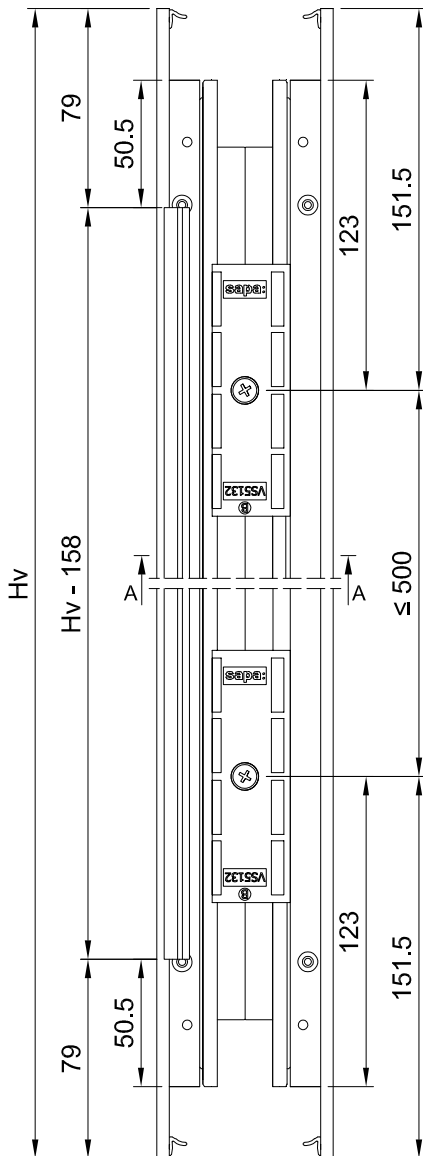
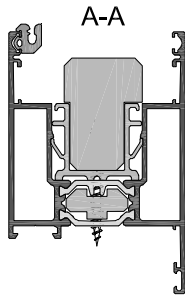
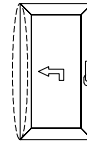



RINFORZO ANTA - OPTIONAL

INSTALLAZIONE C9C001

2 / 2

-SH-
-SI-
I

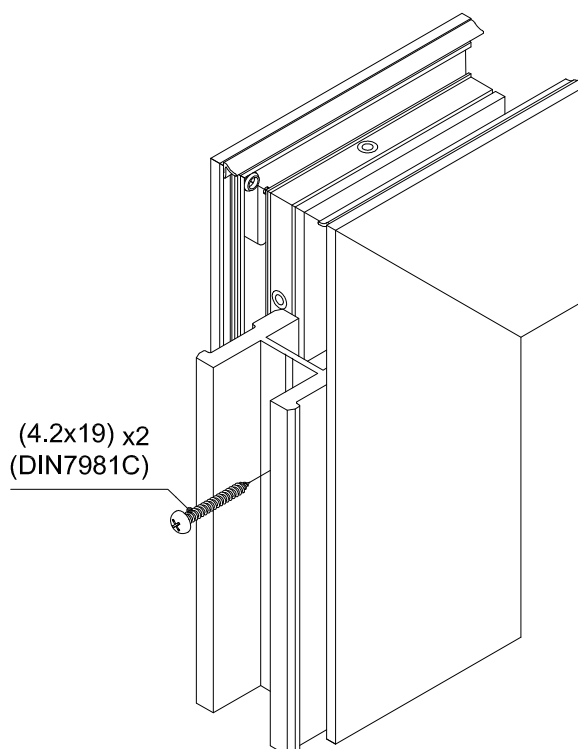
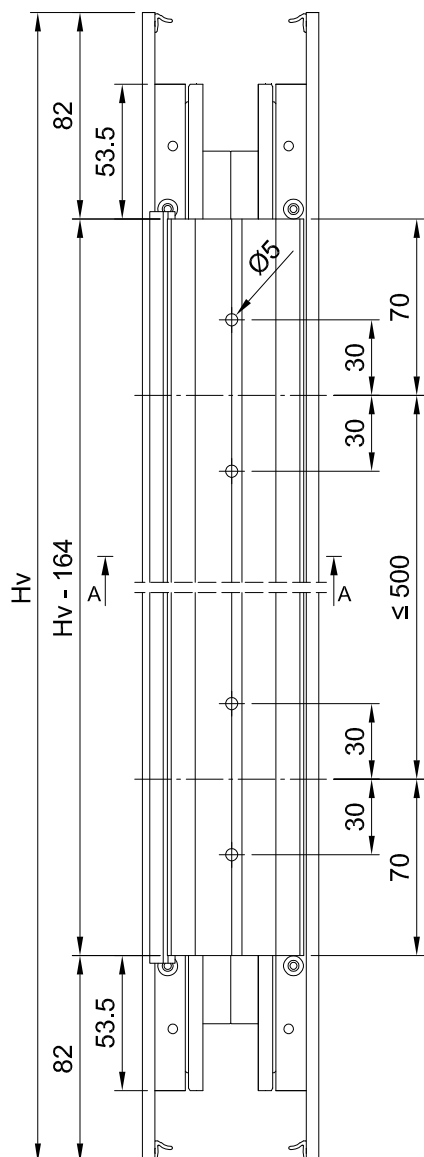
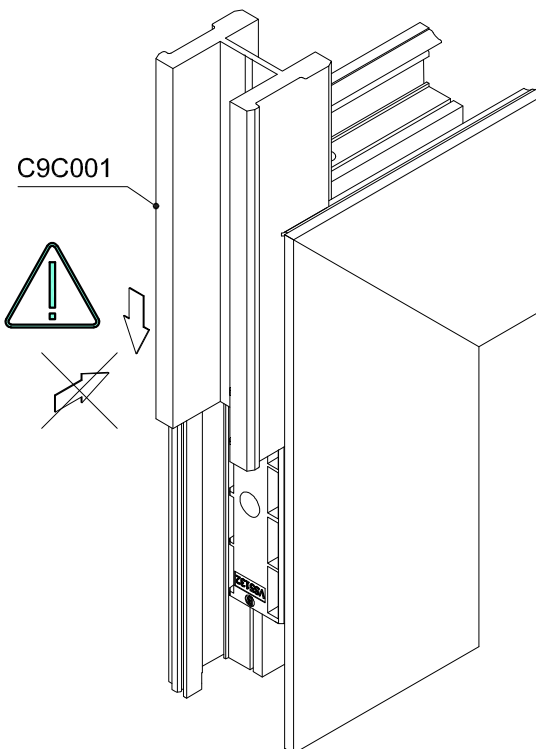
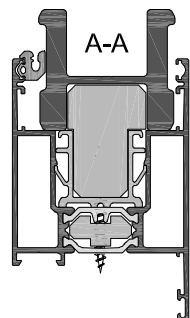
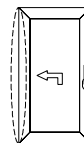

 C160-ASS-2176L

LATO FERRAMENTA ALZANTE-SCORREVOLE - INSTALLAZIONE RU9094

1 / 3

-SHI
-SI
I

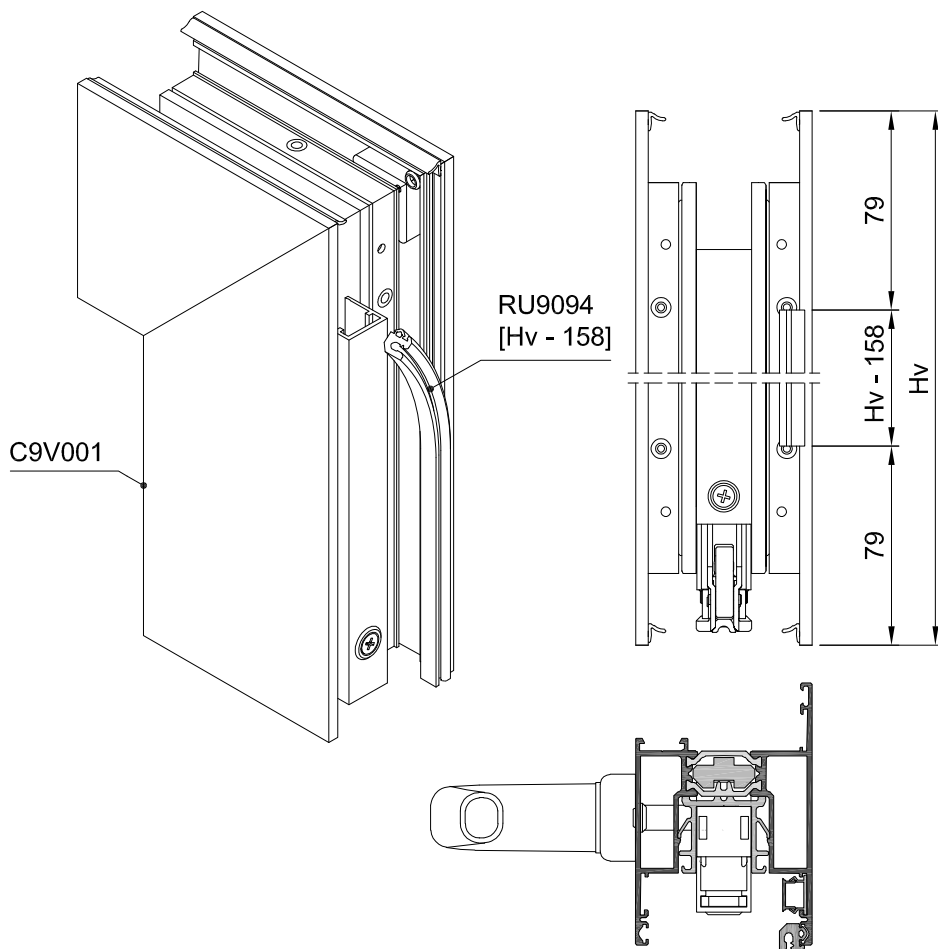
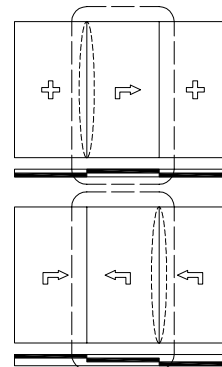
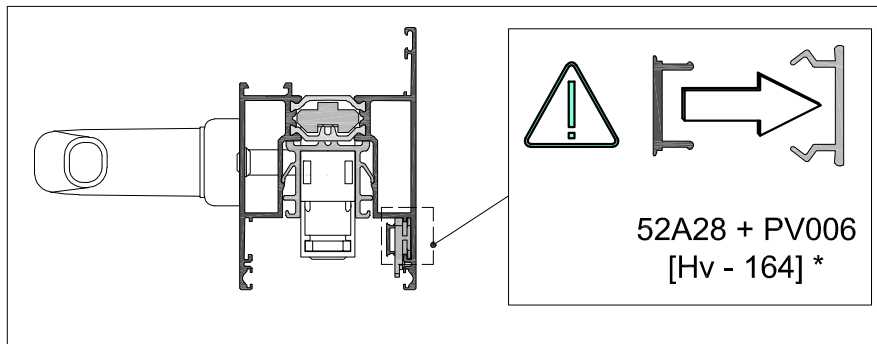
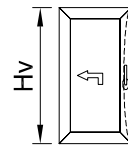

* PV006 + 52A28 devono essere installati prima del montaggio dell'anta.



RINFORZO ANTA - OPTIONAL

LATO FERRAMENTA ALZANTE-SCORREVOLE - PREPARAZIONE C9C001

2 / 3

-SH-
-SI-
I

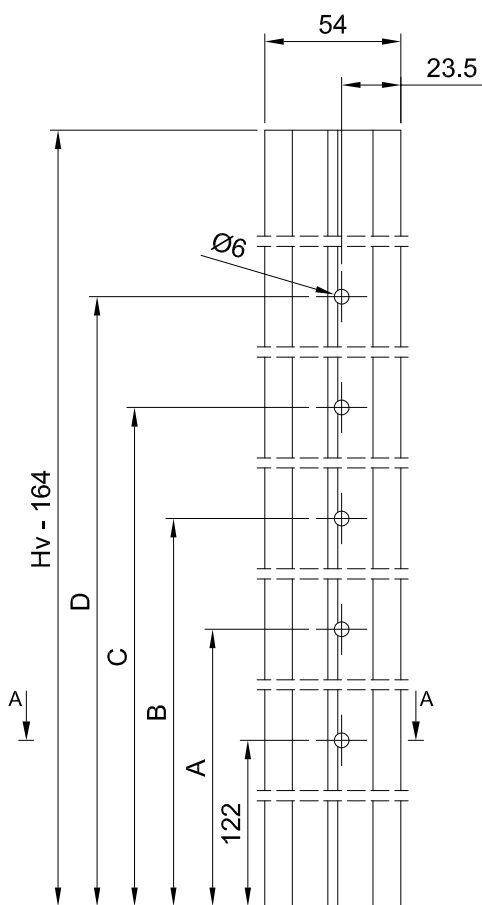
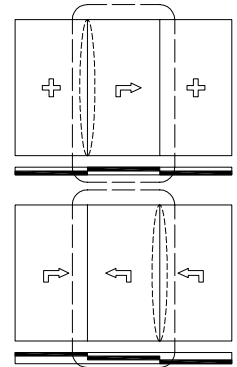
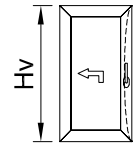

A-A

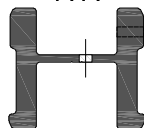

C9C001

	Hv	A	B	C	D	
ZB0034	1904 - 2203	622	1072	1472	/	
ZB0035	2204 - 2503			1772		
ZB0036	2504 - 2803			2072		
ZB0035*	2804 - 3103			1772		Hv - 407
ZB0036*	3104 - 3403			2072		
ZB0033	1303 - 1903	/	472	872	/	

* + ZB0046

LATO FERRAMENTA ALZANTE-SCORREVOLE - INSTALLAZIONE C9C001

3 / 3

-SH-
-SI-
I

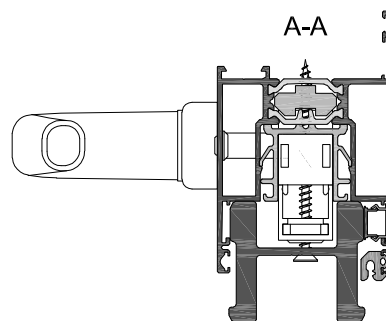
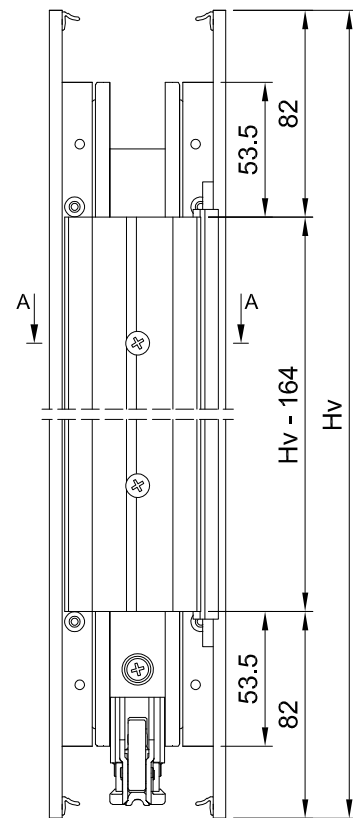
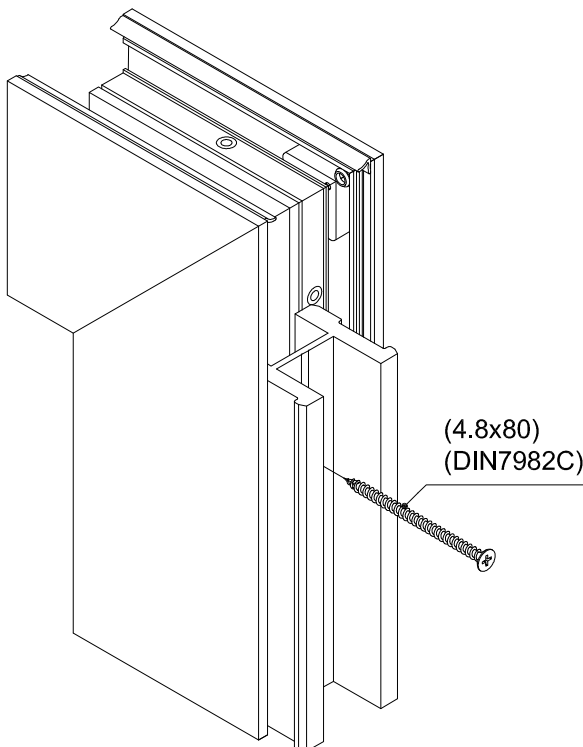
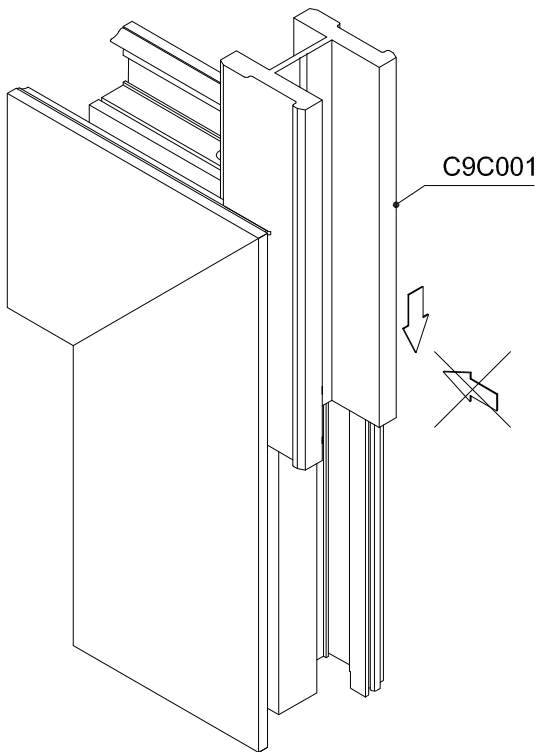
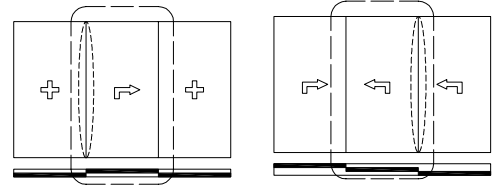
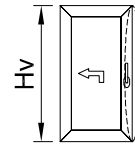



ASSEMBLAGGIO ACCESSORI ANTA

CONTENUTO

Assemblaggio accessori anta.....	J.9.1
Contenuto.....	J.9.1
Installazione distanziatore VS5131.....	J.9.2
Lavorazione profilato anta inserimento tappo terminali.....	J.9.3
Anta standard - installazione VS9149 e RU9094.....	J.9.4
Anta standard - preparazione labirinto.....	J.9.5
Anta standard - assemblaggio labirinto.....	J.9.6
Anta standard - installazione BT6013 e C9A001.....	J.9.7
Anta fissa soglia ribassata - installazione VS9149 e RU9094.....	J.9.8
Anta fissa soglia ribassata - preparazione labirinto.....	J.9.9
Anta fissa soglia ribassata - assemblaggio labirinto.....	J.9.10
Anta fissa soglia ribassata - installazione BT6013 e C9A001.....	J.9.11
Connessione ante alzante-scorrevole schema 4 ante - taglio verticale RU0099..	J.9.12
Anta passiva schema 4 ante - preparazione del C9C002.....	J.9.13
Anta passiva schema 4 ante - installazione tappo sigillatura inferiore.....	J.9.16
Anta passiva schema 4 ante - installazione tappo sigillatura superiore.....	J.9.18

INSTALLAZIONE DISTANZIATORE VS5131

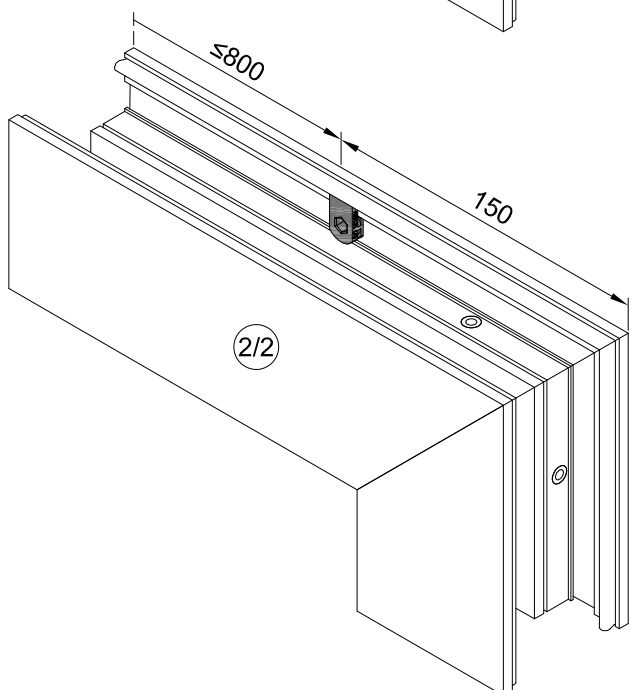
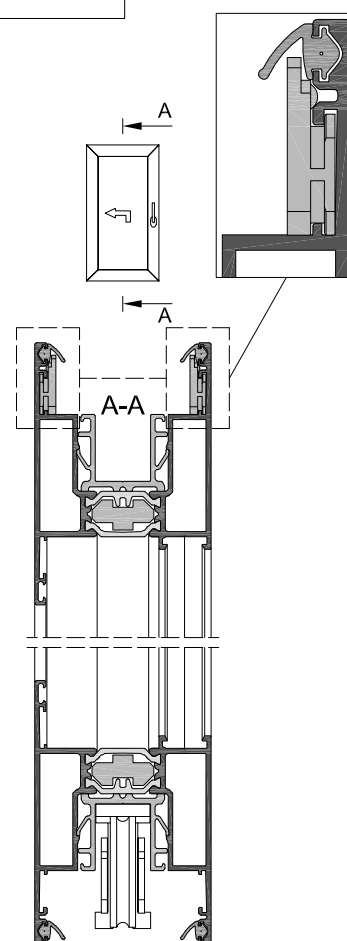
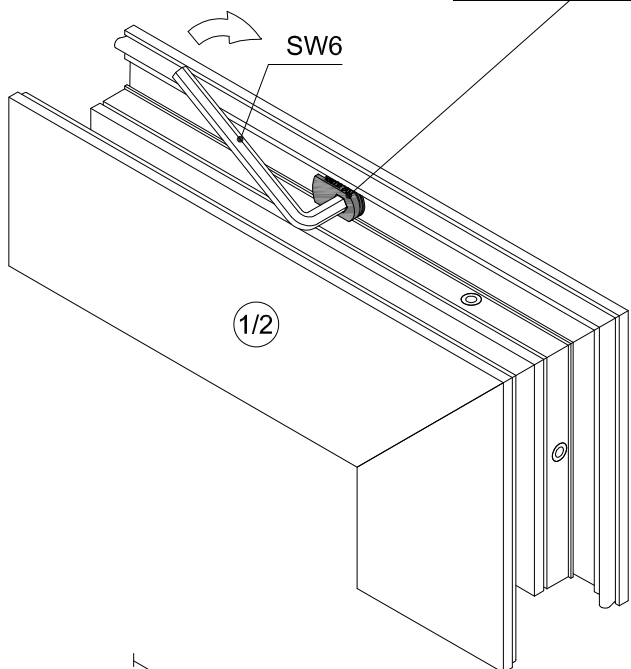
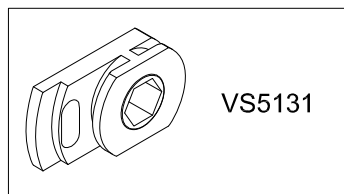
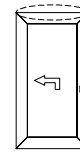



ASSEMBLAGGIO ACCESSORI ANTA

LAVORAZIONE PROFILATO ANTA INSERIMENTO TAPPO TERMINALI

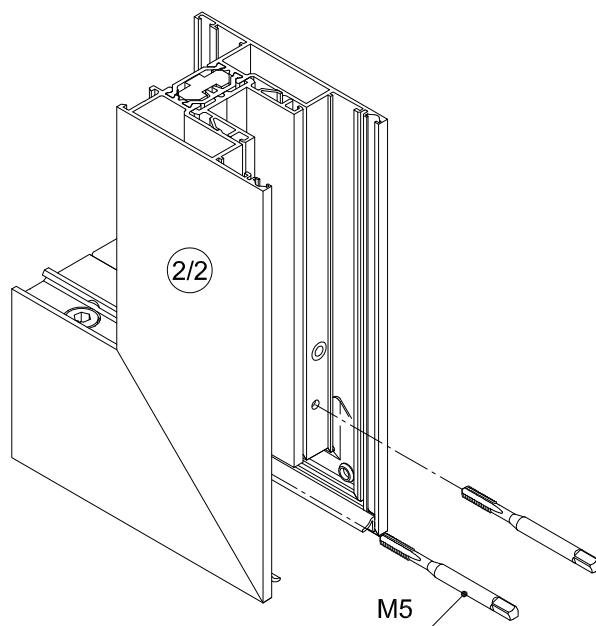
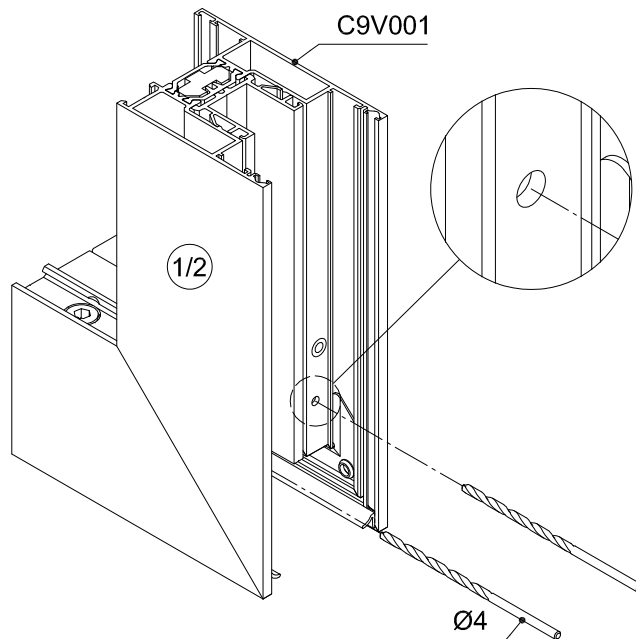
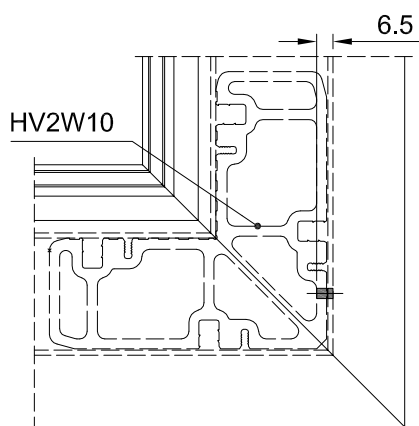
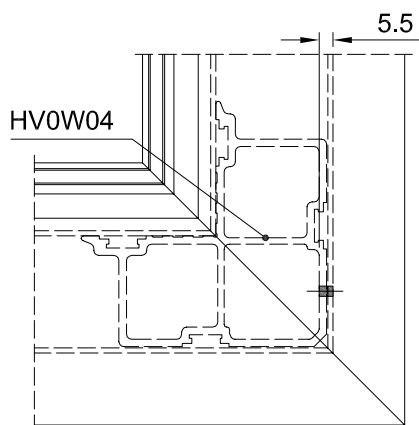
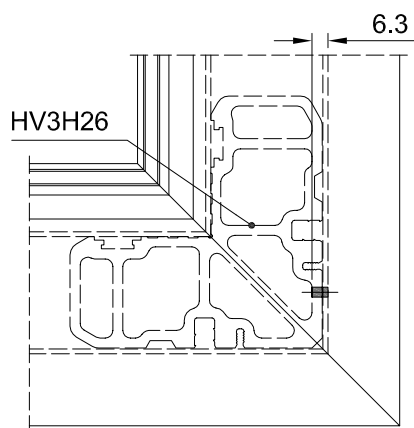
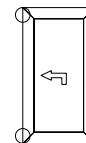

ANTA STANDARD - INSTALLAZIONE VS9149 E RU9094

1 / 4



J.4.10
J.9.3

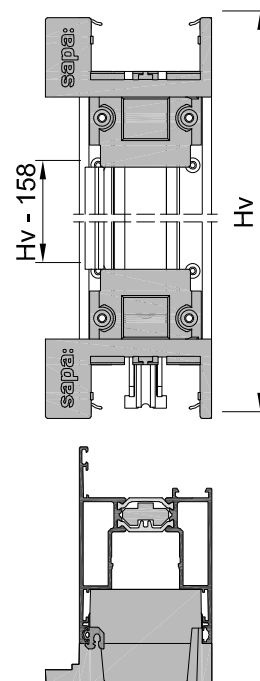
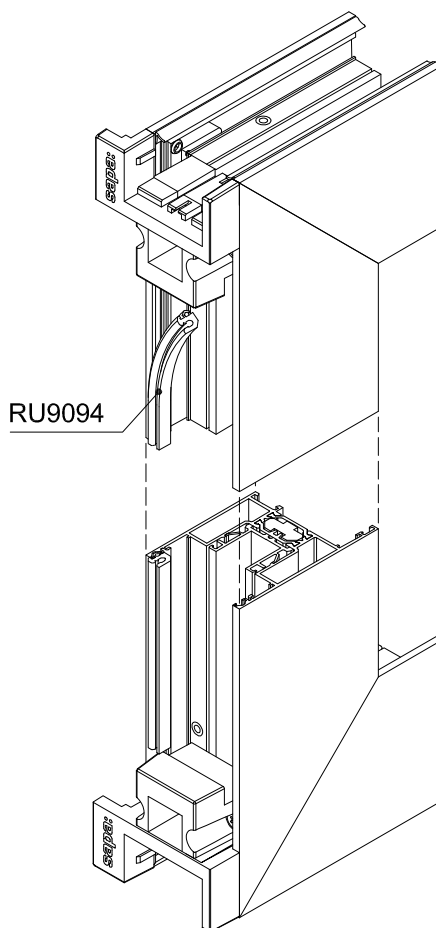
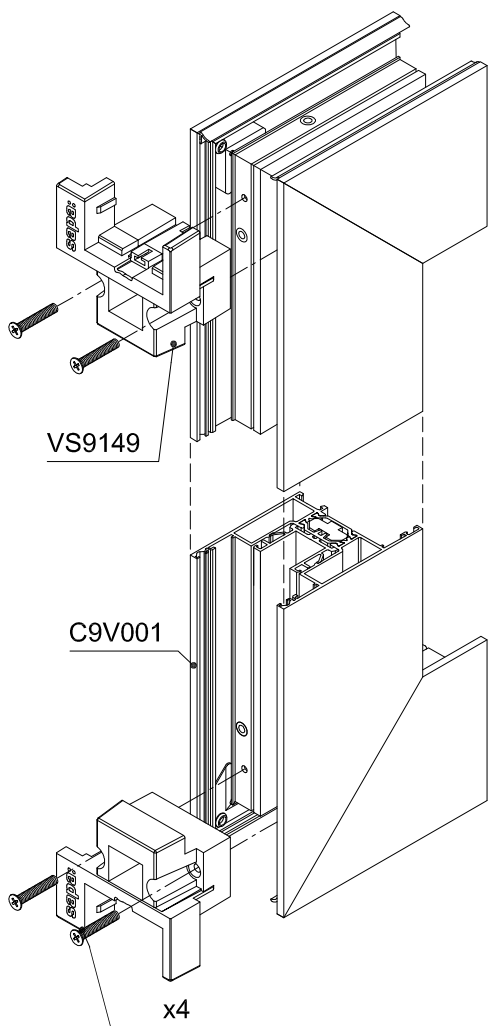
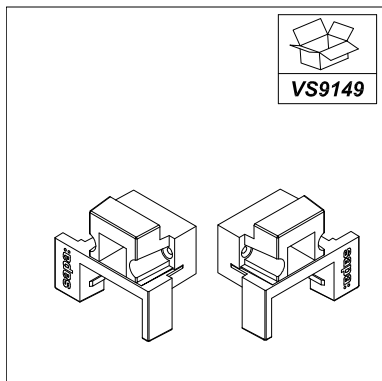
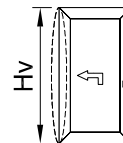



ASSEMBLAGGIO ACCESSORI ANTA

ANTA STANDARD - PREPARAZIONE LABIRINTO

2 / 4

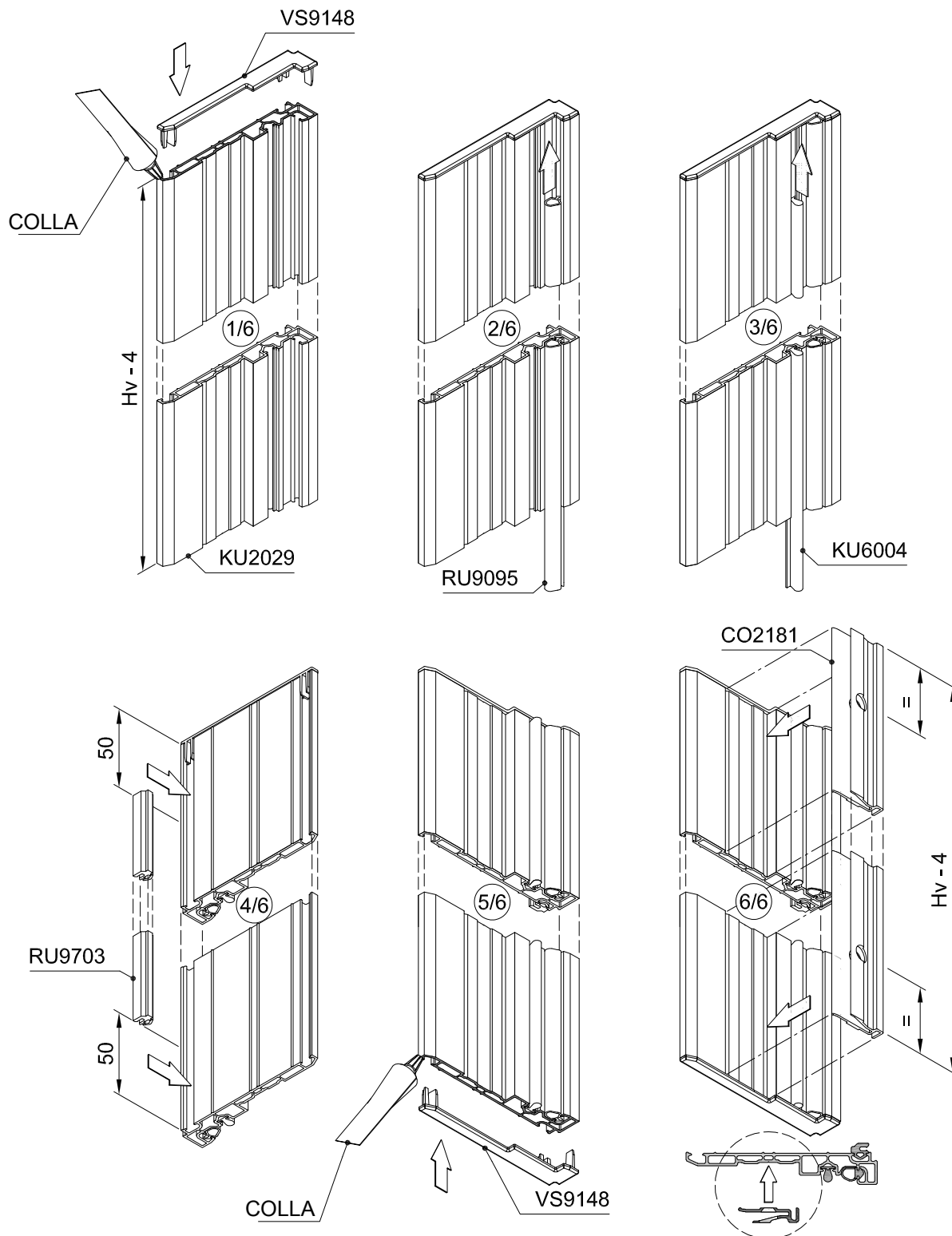
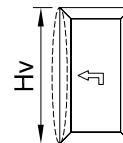

ANTA STANDARD - ASSEMBLAGGIO LABIRINTO

3 / 4

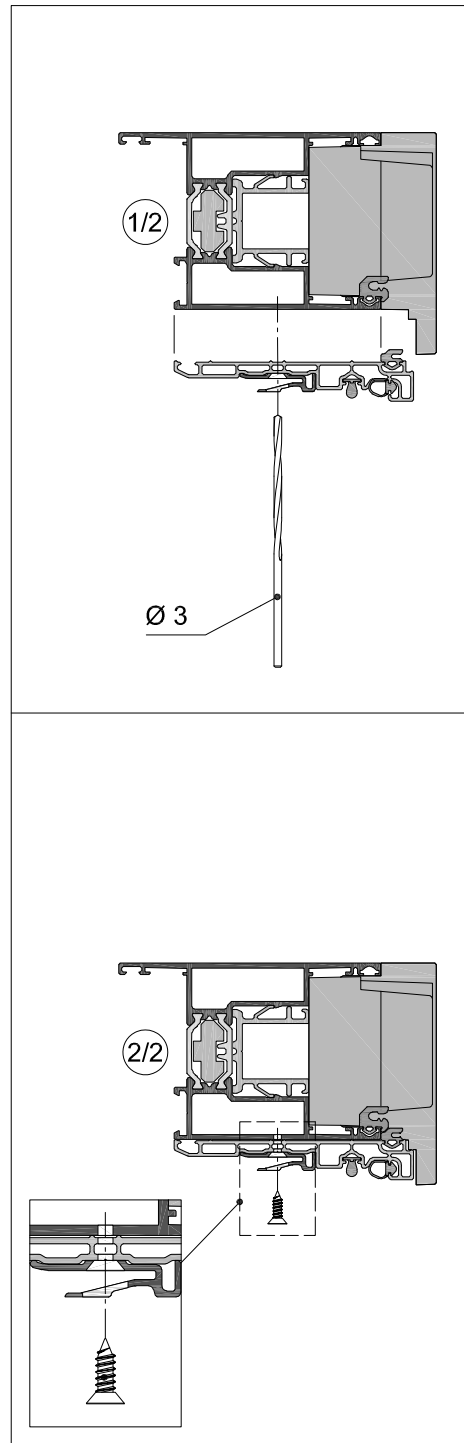
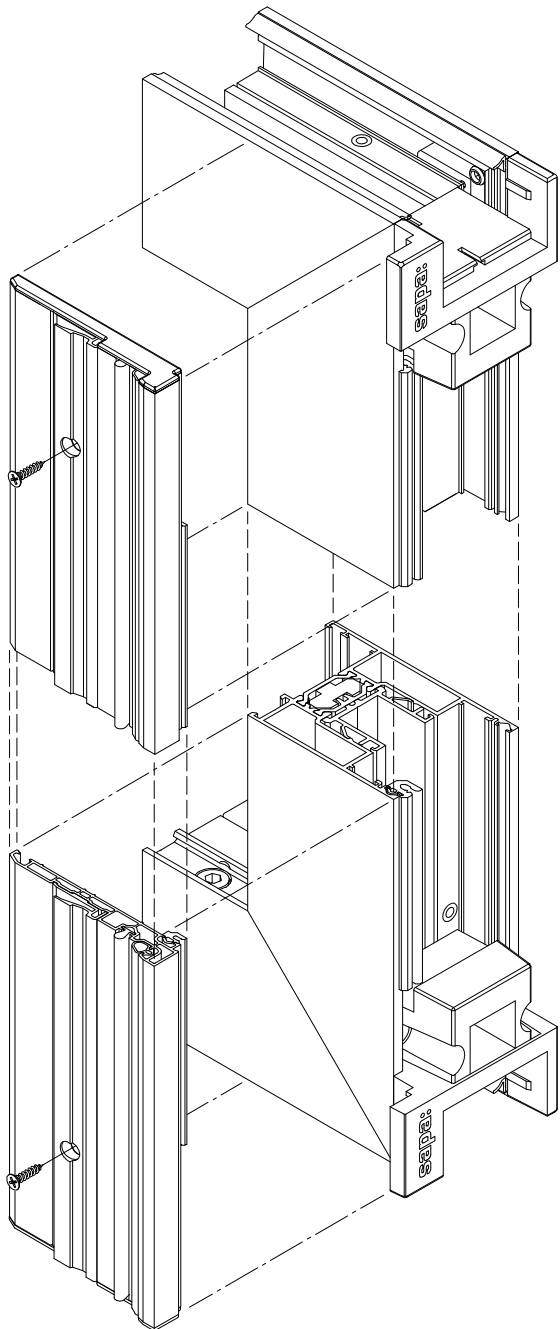
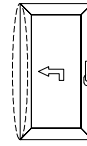



ASSEMBLAGGIO ACCESSORI ANTA

ANTA STANDARD - INSTALLAZIONE BT6013 E C9A001

4 / 4

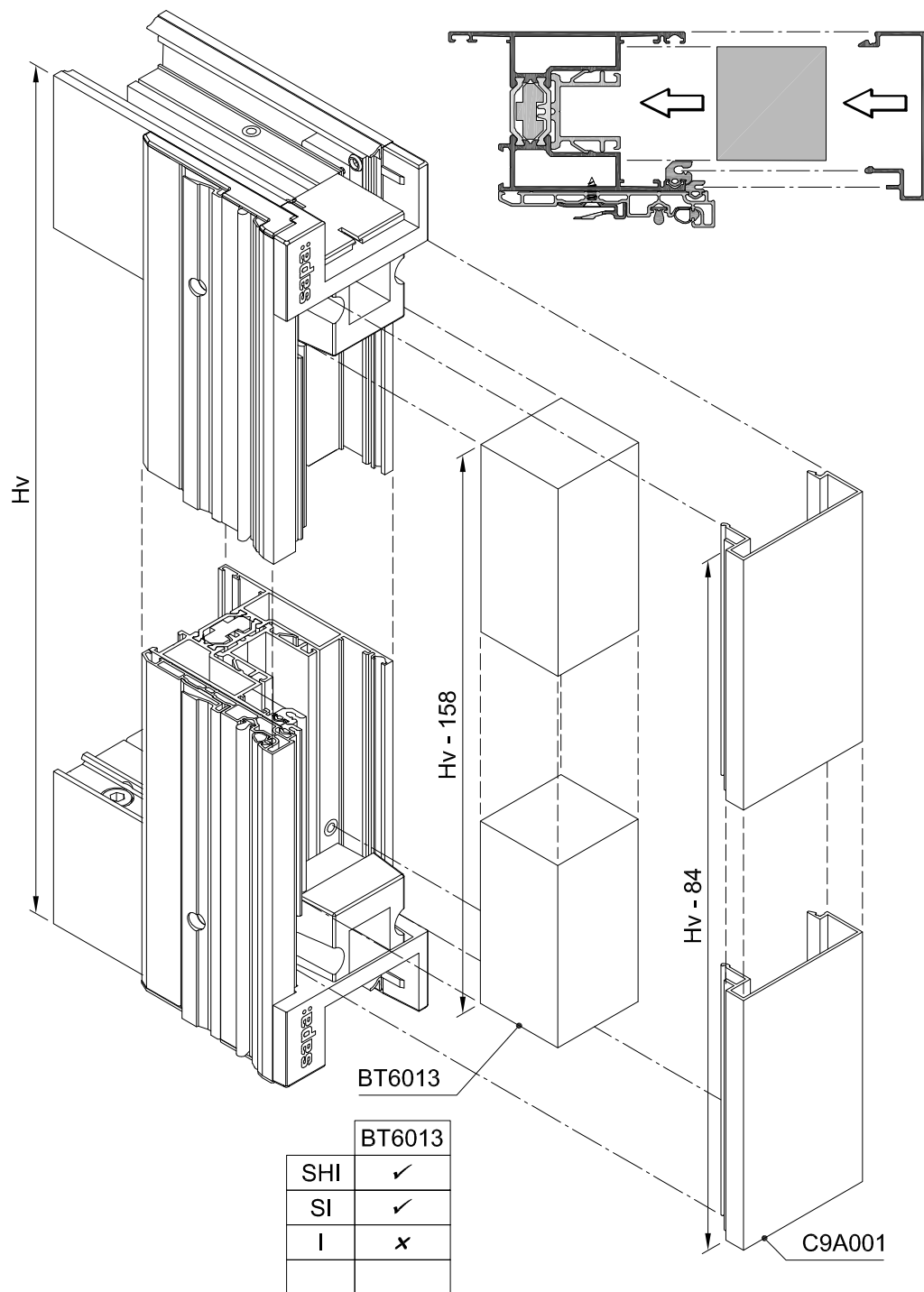
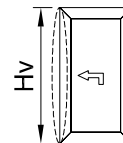

BT6013	
SHI	✓
SI	✓
I	x

ANTA FISSA SOGLIA RIBASSATA - INSTALLAZIONE VS9149 E RU9094

1 / 4

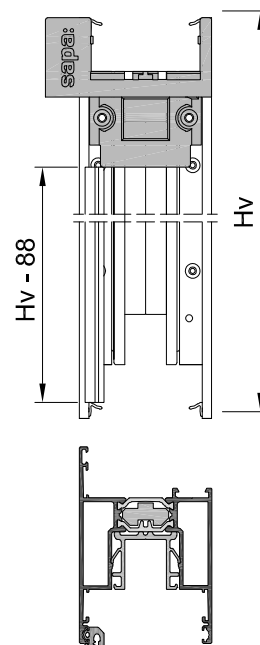
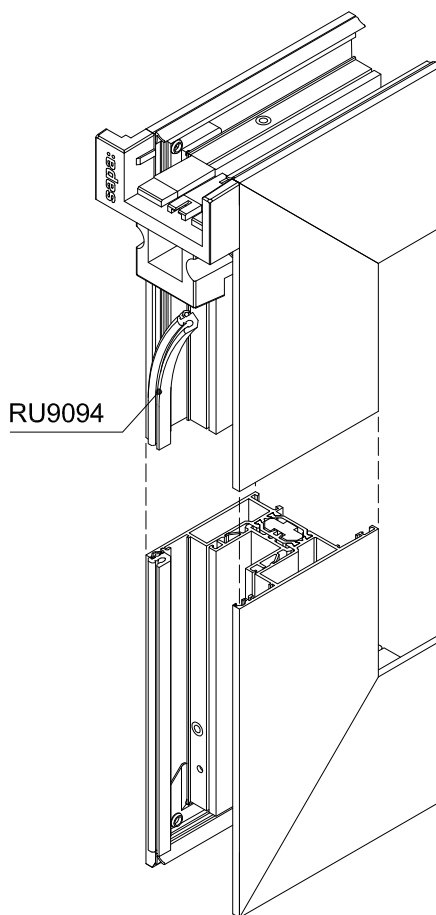
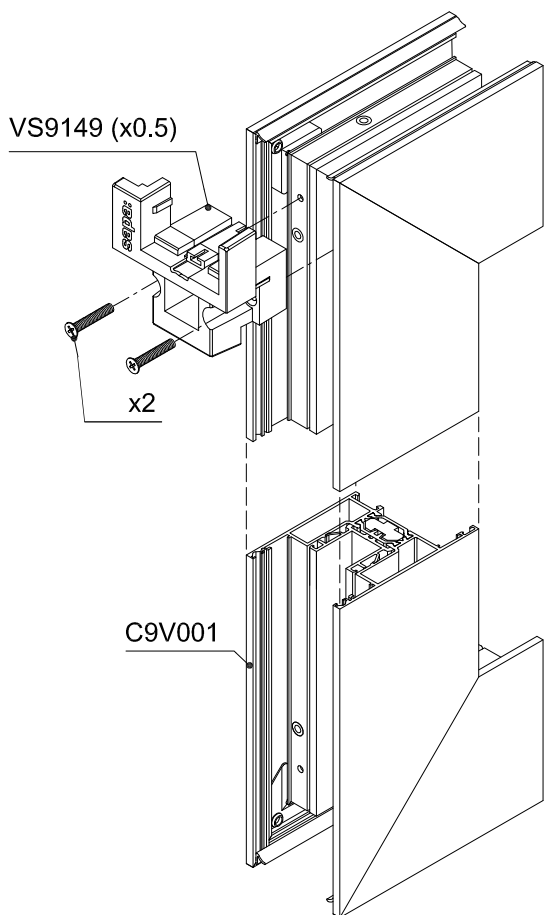
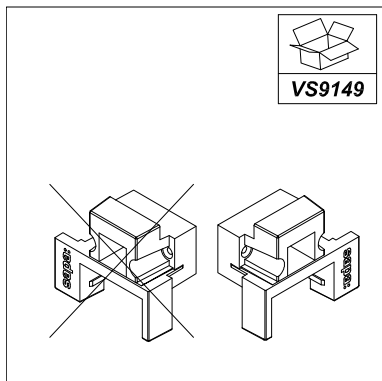
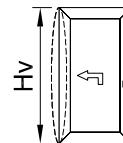
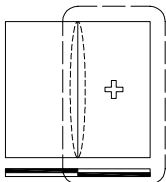



ASSEMBLAGGIO ACCESSORI ANTA

ANTA FISSA SOGLIA RIBASSATA - PREPARAZIONE LABIRINTO

2 / 4

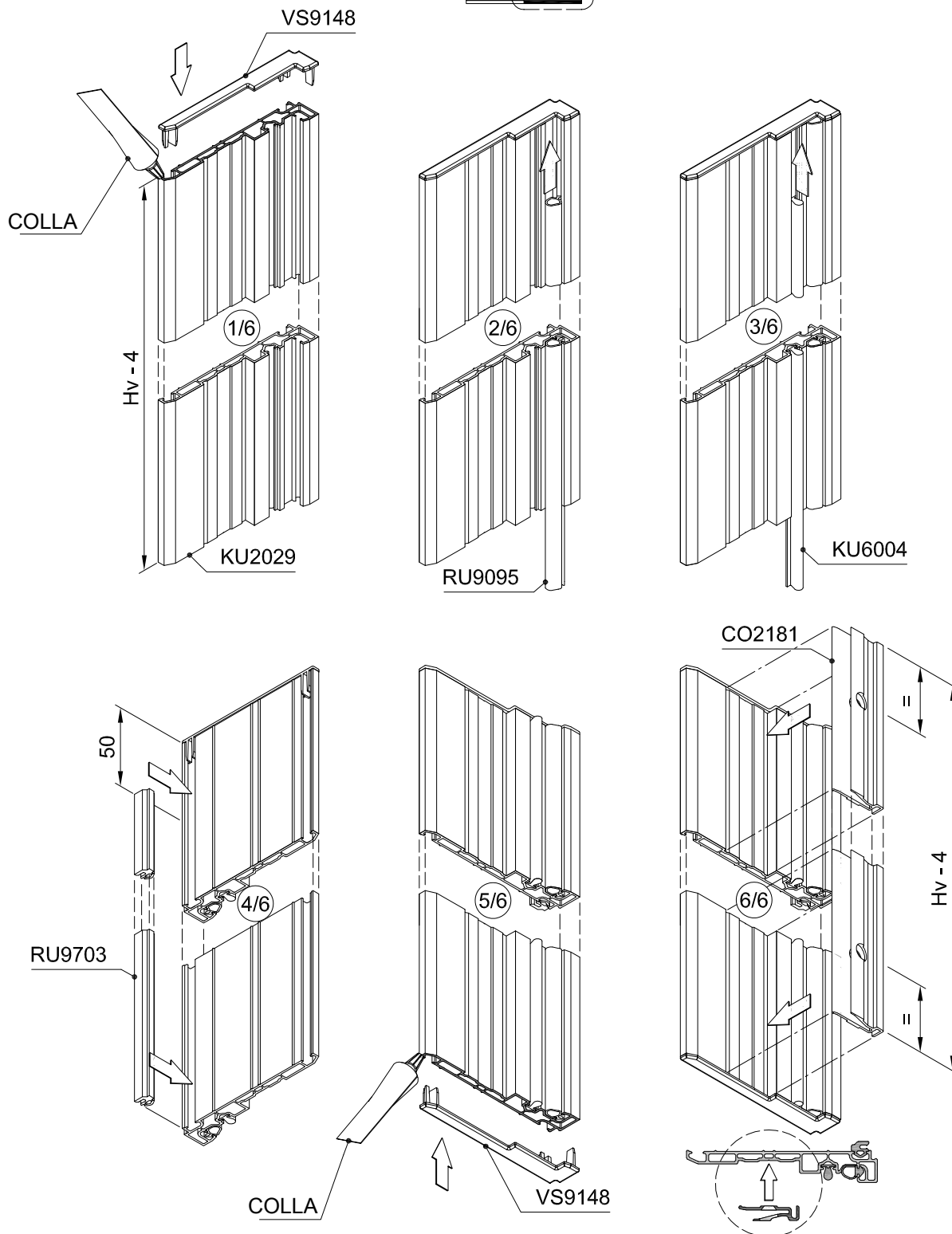
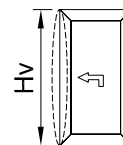
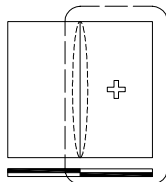

ANTA FISSA SOGLIA RIBASSATA - ASSEMBLAGGIO LABIRINTO

3 / 4

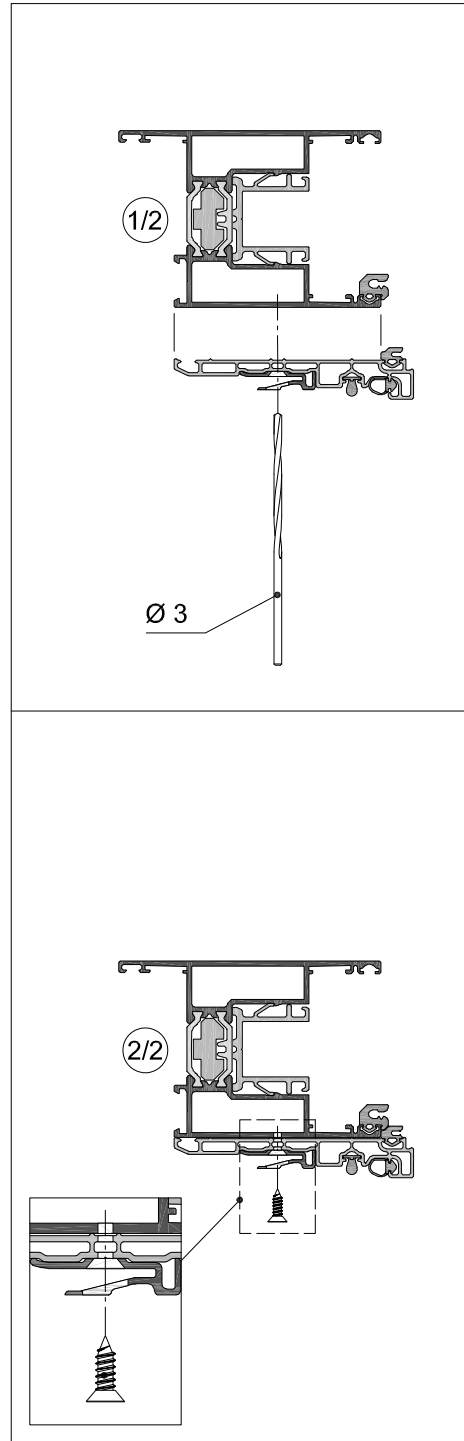
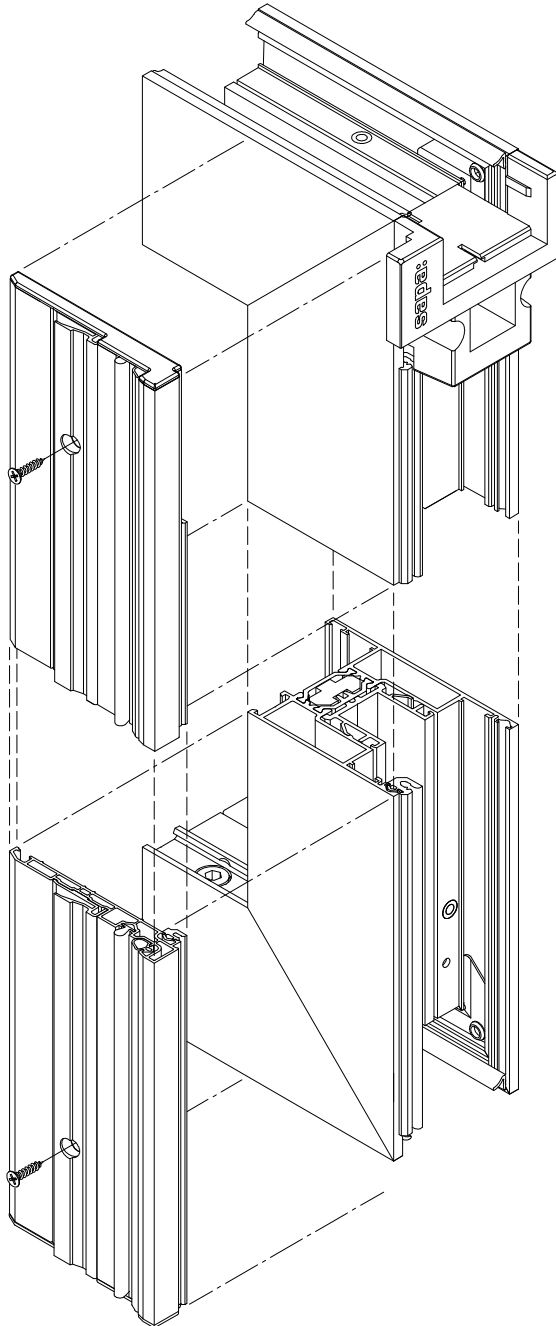
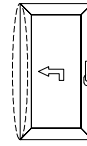
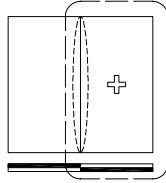

* - Black



ASSEMBLAGGIO ACCESSORI ANTA

ANTA FISSA SOGLIA RIBASSATA - INSTALLAZIONE BT6013 E C9A001

4 / 4

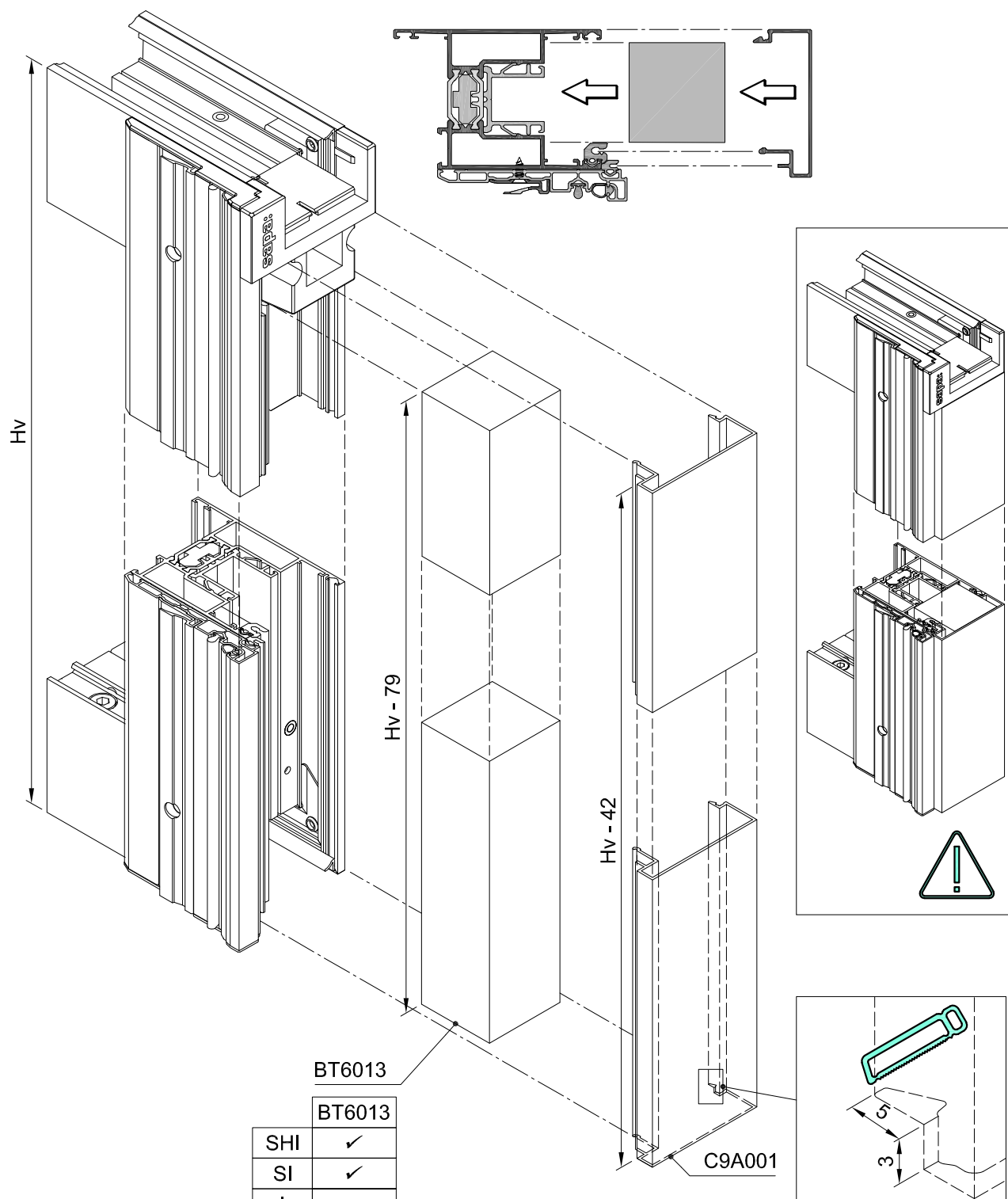
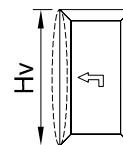
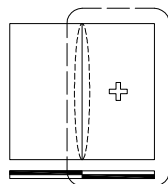

BT6013

	BT6013
SHI	✓
SI	✓
I	x

C9A001

C160-ASS-2276L

CONNESSIONE ANTE ALZANTE-SCORREVOLE SCHEMA 4 ANTE - TAGLIO VERTICALE RU0099

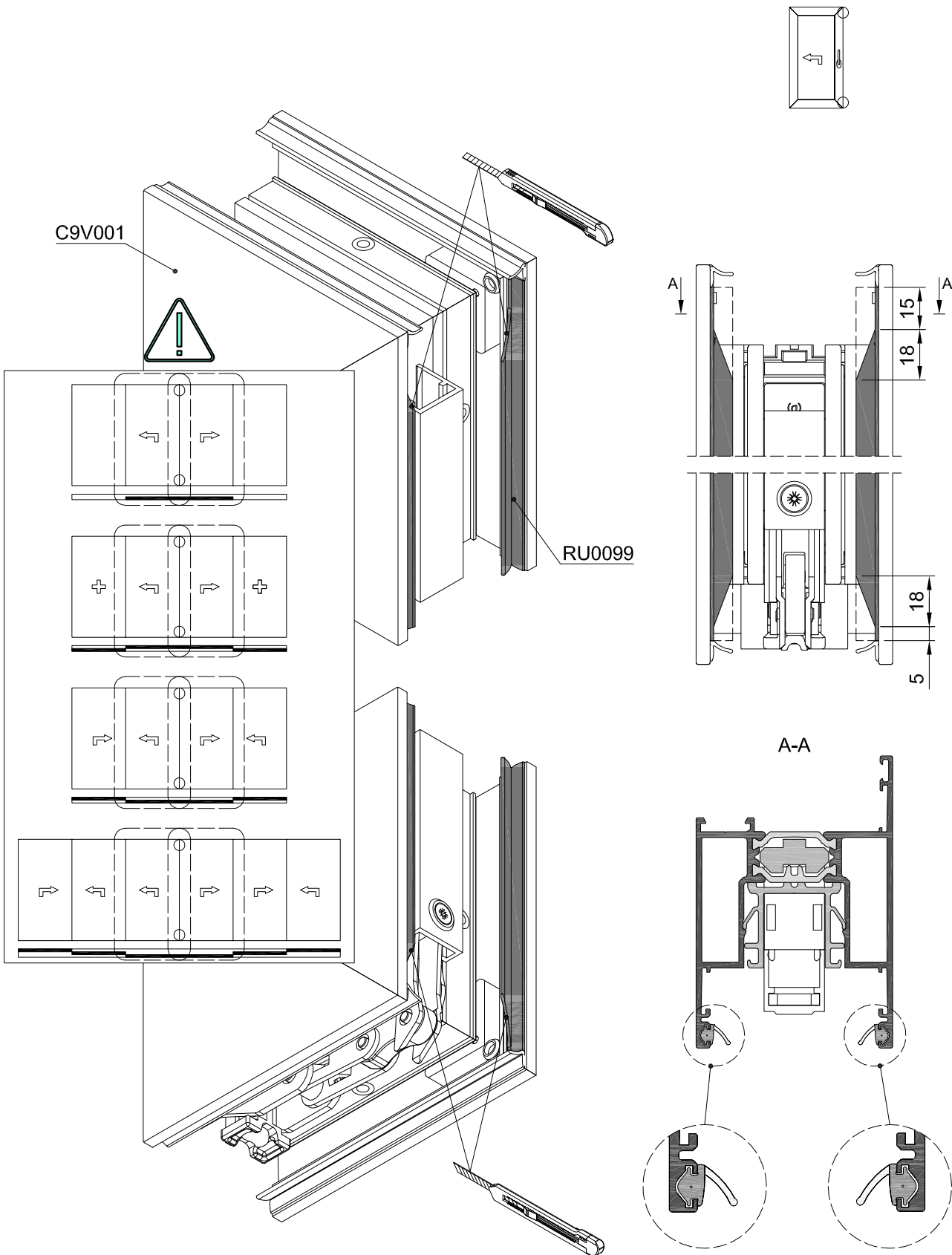



ASSEMBLAGGIO ACCESSORI ANTA

ANTA PASSIVA SCHEMA 4 ANTE - PREPARAZIONE DEL C9C002

1 / 6

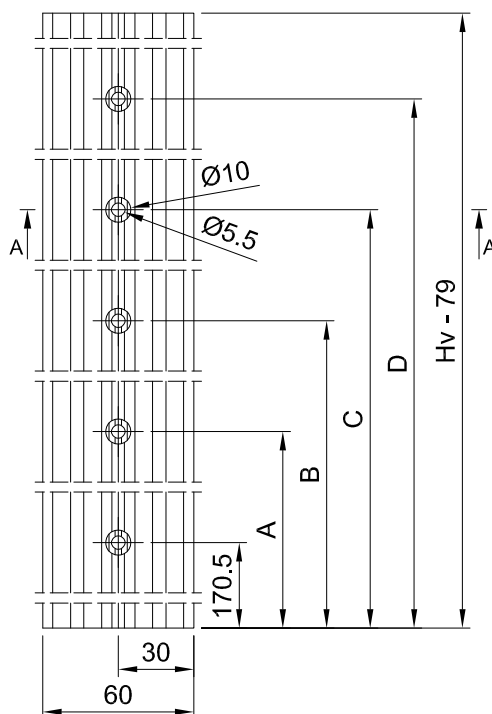
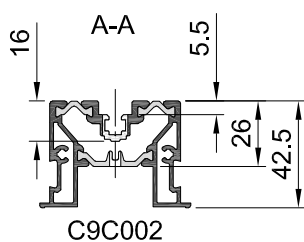
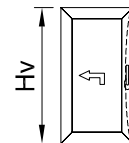

A	B	C	D		Hv
670.5	1120.5	1520.5	/	ZB0034	1904 - 2203
		1820.5		ZB0035	2204 - 2503
		2120.5		ZB0036	2504 - 2803
		1820.5	Hv - 358,5	ZB0035*	2804 - 3103
		2120.5		ZB0036*	3104 - 3403
/	520.5	920.5	/	ZB0033	1303 - 1903

* + ZB0046

ANTA PASSIVA SCHEMA 4 ANTE - ASSEMBLAGGIO C9C002

2 / 6

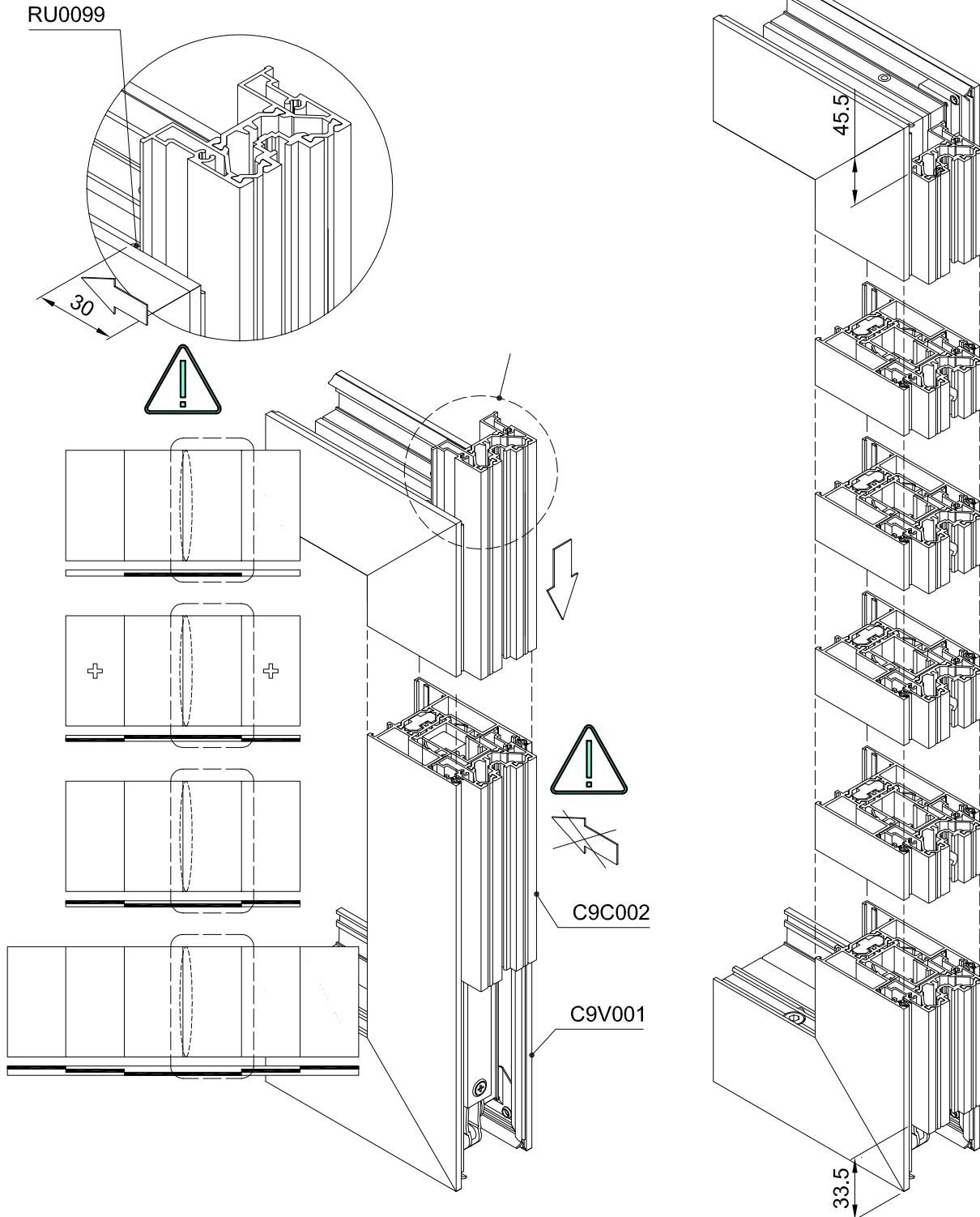
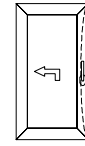

 C160-ASS-2186L



ASSEMBLAGGIO ACCESSORI ANTA

ANTA PASSIVA SCHEMA 4 ANTE - ASSEMBLAGGIO C9C002

3 / 6

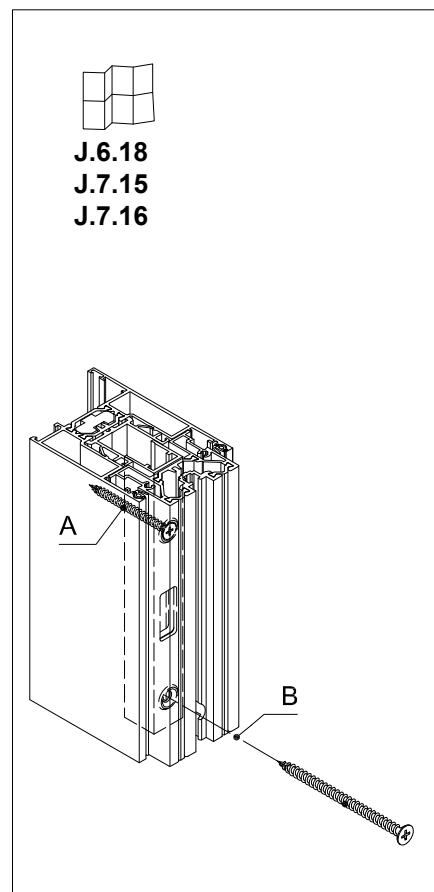
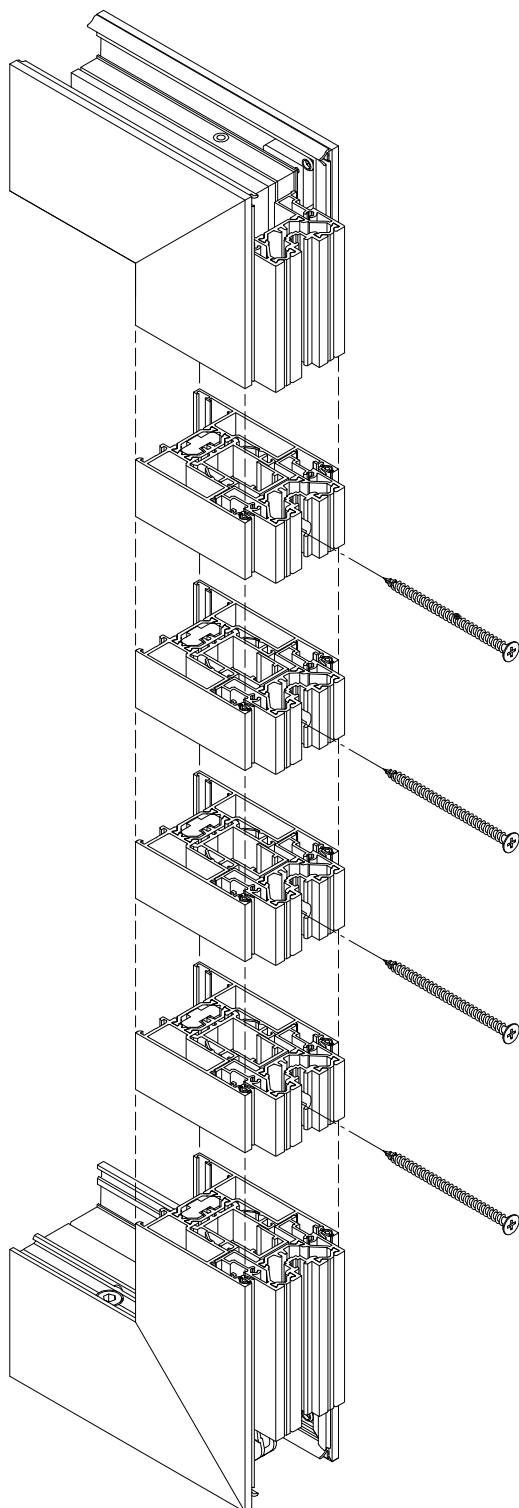
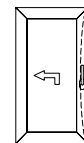

ANTA PASSIVA SCHEMA 4 ANTE - INSTALLAZIONE TAPPO SIGILLATURA INFERIORE

4 / 6



J.11.3

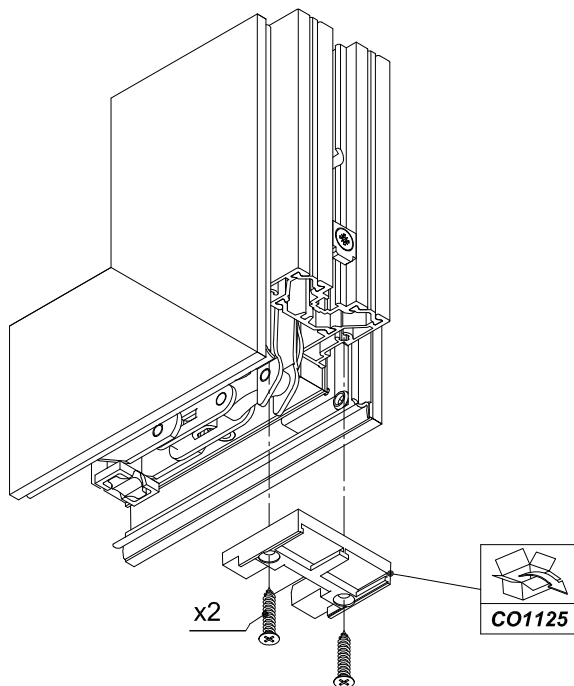
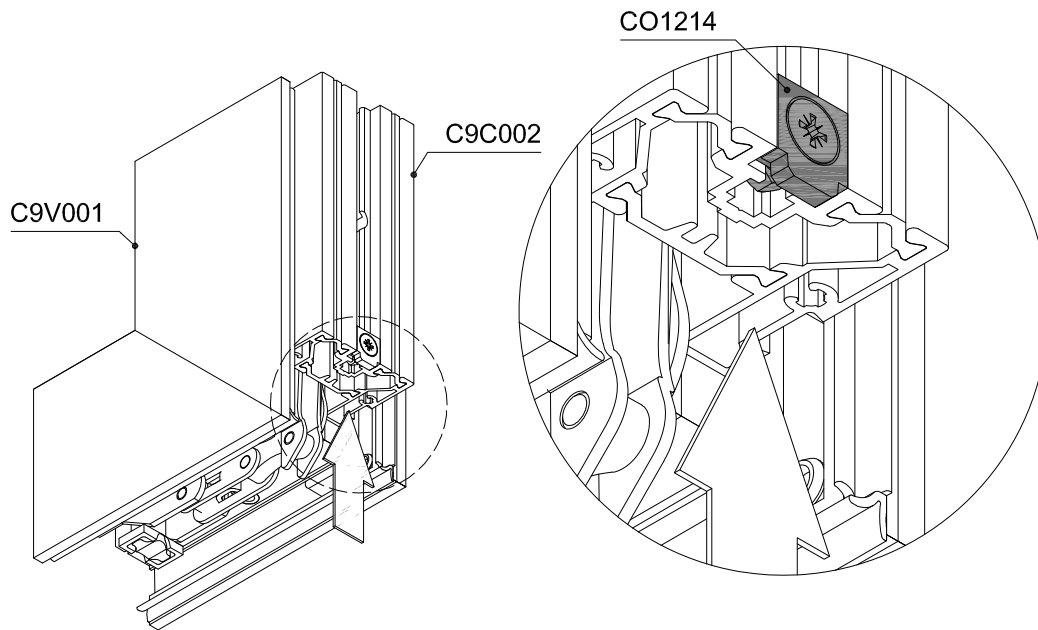
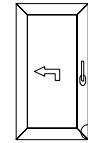



ASSEMBLAGGIO ACCESSORI ANTA

ANTA PASSIVA SCHEMA 4 ANTE - INSTALLAZIONE PUNTI DI CHIUSURA

5 / 6



J.11.4

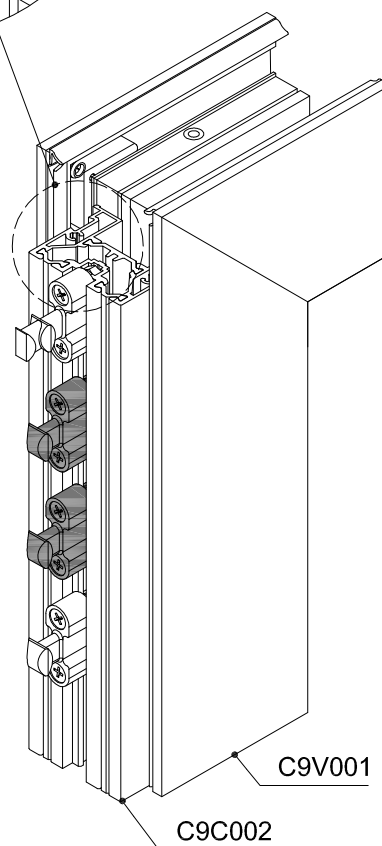
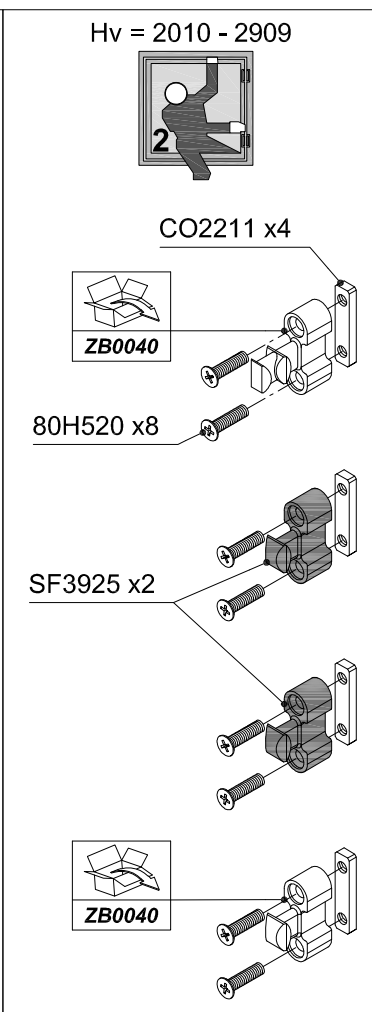
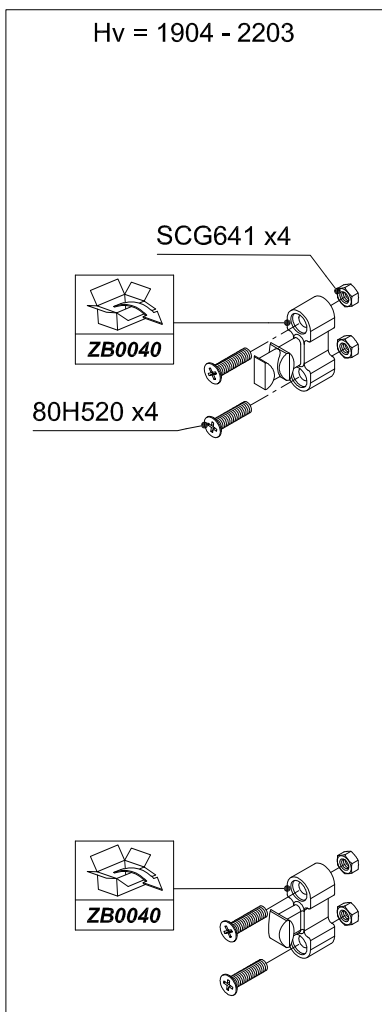
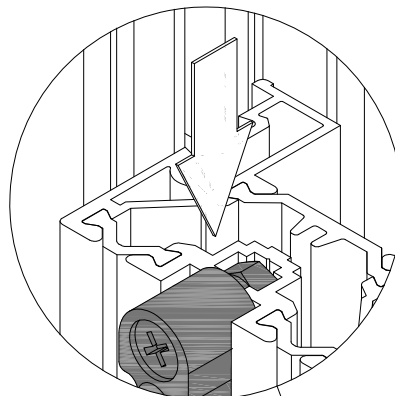
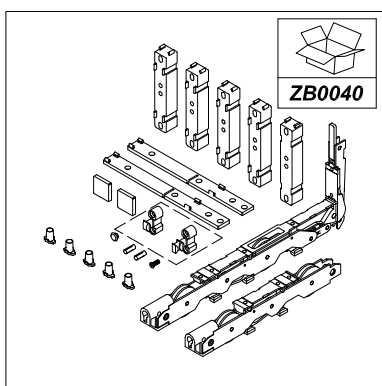
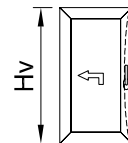

ANTA PASSIVA SCHEMA 4 ANTE - INSTALLAZIONE TAPPO SIGILLATURA SUPERIORE

6 / 6



J.11.3

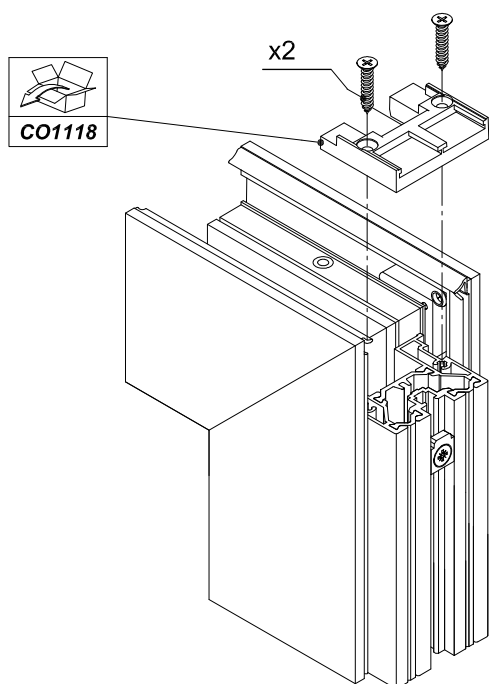
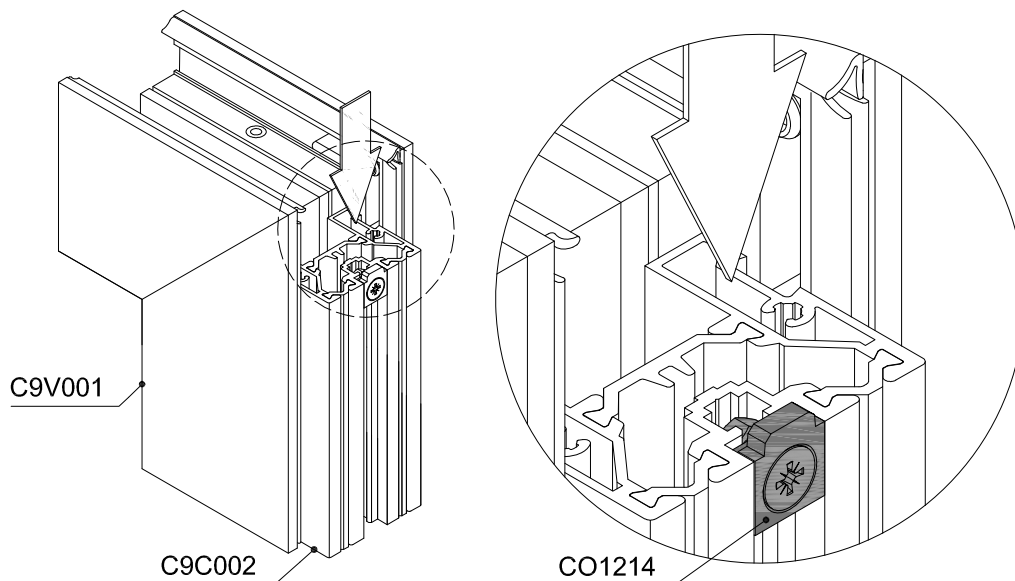
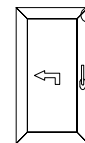



INSTALLAZIONE ANTE SU TELAI

CONTENUTO

Installazione ante su telai.....	J.10.1
Contenuto.....	J.10.1
1-binario - assemblaggio anta.....	J.10.2
1-binario - assemblaggio cartellina copertura telaio C9A012 - inferiore.....	J.10.3
1-binario - assemblaggio cartellina copertura telaio C9A012 - superiore.....	J.10.4
1-binario - assemblaggio cartellina copertura telaio C9A012 - laterale.....	J.10.5
1-binario (C9K010) - assemblaggio anta.....	J.10.6
1-binario (C9K010) - fissaggio tappo di tenuta centrale superiore.....	J.10.7
1-binario (C9K010) - C9A010 assemblaggio cartellina copertura telaio - inferiore.....	J.10.8
1-binario (C9K010) - C9A010 assemblaggio cartellina copertura telaio - superiore.....	J.10.9
1-binario (C9K010) - C9A010 assemblaggio cartellina copertura telaio - laterale.....	J.10.10
1-binario (C9K010) - C9A010 cartellina copertura telaio schema 4 ante - inferiore.....	J.10.11
1-binario (C9K010) - C9A010 cartellina copertura telaio schema 4 ante - superiore.....	J.10.12
Uso standard.....	J.10.13
Aggiustamenti.....	J.10.13
1-binario anta fissa soglia ribassata - utilizzo VS5128/VS5129.....	J.10.13
1-binario anta fissa soglia ribassata - rimozione profilato cartellina.....	J.10.14
1-binario anta fissa soglia ribassata - installazione VS5129 e BT6015/BT6014.....	J.10.15
1-binario anta fissa soglia ribassata - blocchi guida foratura.....	J.10.16
1-binario anta fissa soglia ribassata - installazione VS5129 e BT6026/BT6027.....	J.10.17
1-binario anta fissa soglia ribassata - posizionamento anta fissa sul telaio.....	J.10.18
1-binario anta fissa soglia ribassata - BT6026/BT6027 e VS5129 superiore.....	J.10.19
1-binario anta fissa soglia ribassata - fissaggio con SCZ617/SCZ834.....	J.10.20
1-binario anta fissa soglia ribassata - tappo di tenuta addizionale superiore dell'anta.....	J.10.22
1-binario anta fissa soglia ribassata - tappo di tenuta superiore e cartellina anta.....	J.10.23
1-binario anta fissa soglia ribassata - posizionamento anta apribile sul telaio.....	J.10.24
1-binario anta fissa soglia ribassata - assemblaggio tappo di tenuta superiore.....	J.10.25
Assemblaggio fine corsa.....	J.10.26

1-BINARIO - ASSEMBLAGGIO ANTA

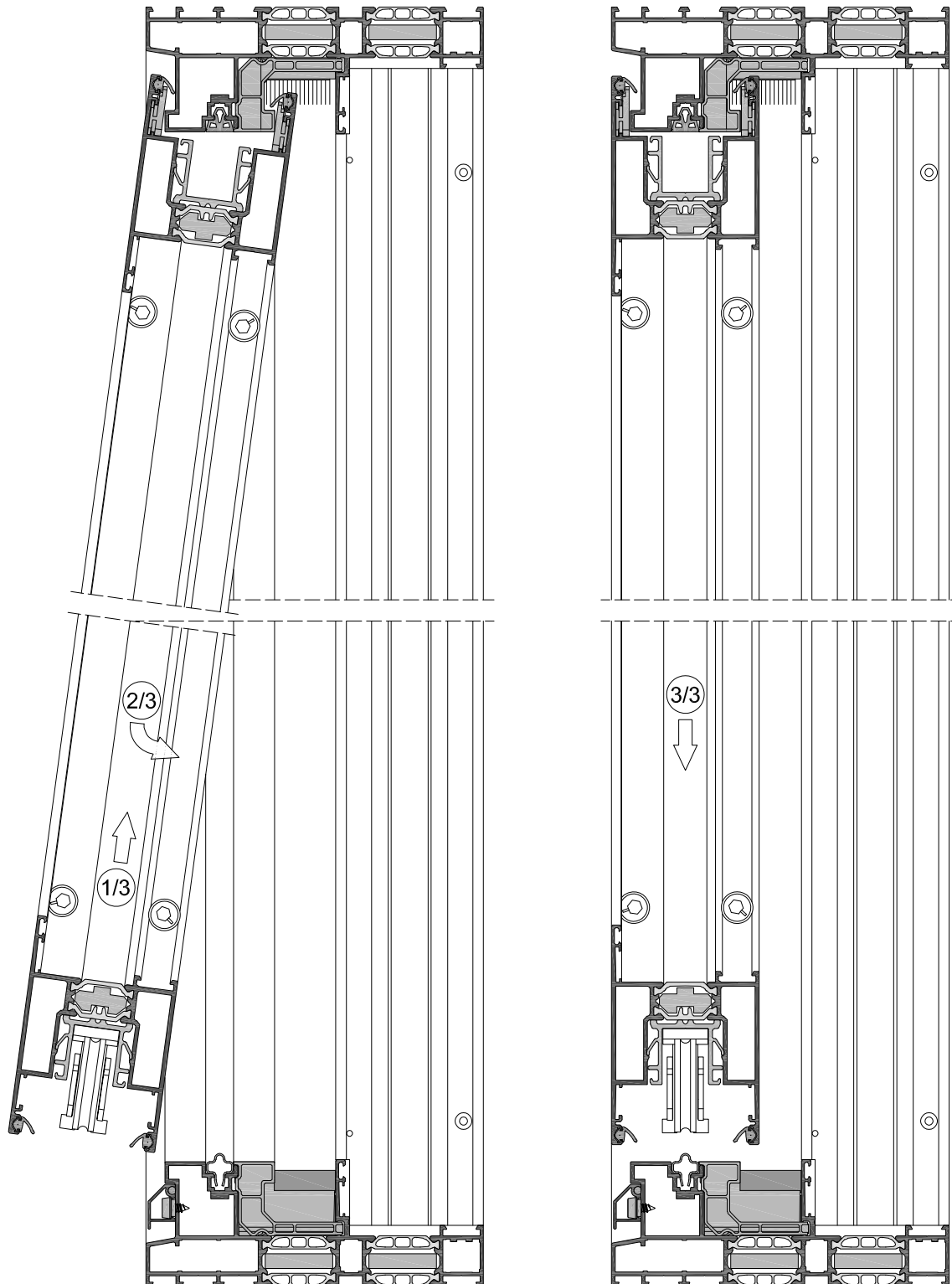
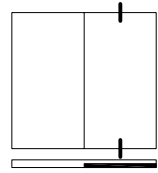



INSTALLAZIONE ANTE SU TELAI

1-BINARIO - ASSEMBLAGGIO CARTELLINA COPERTURA TELAIO C9A012 - INFERIORE

1 / 5

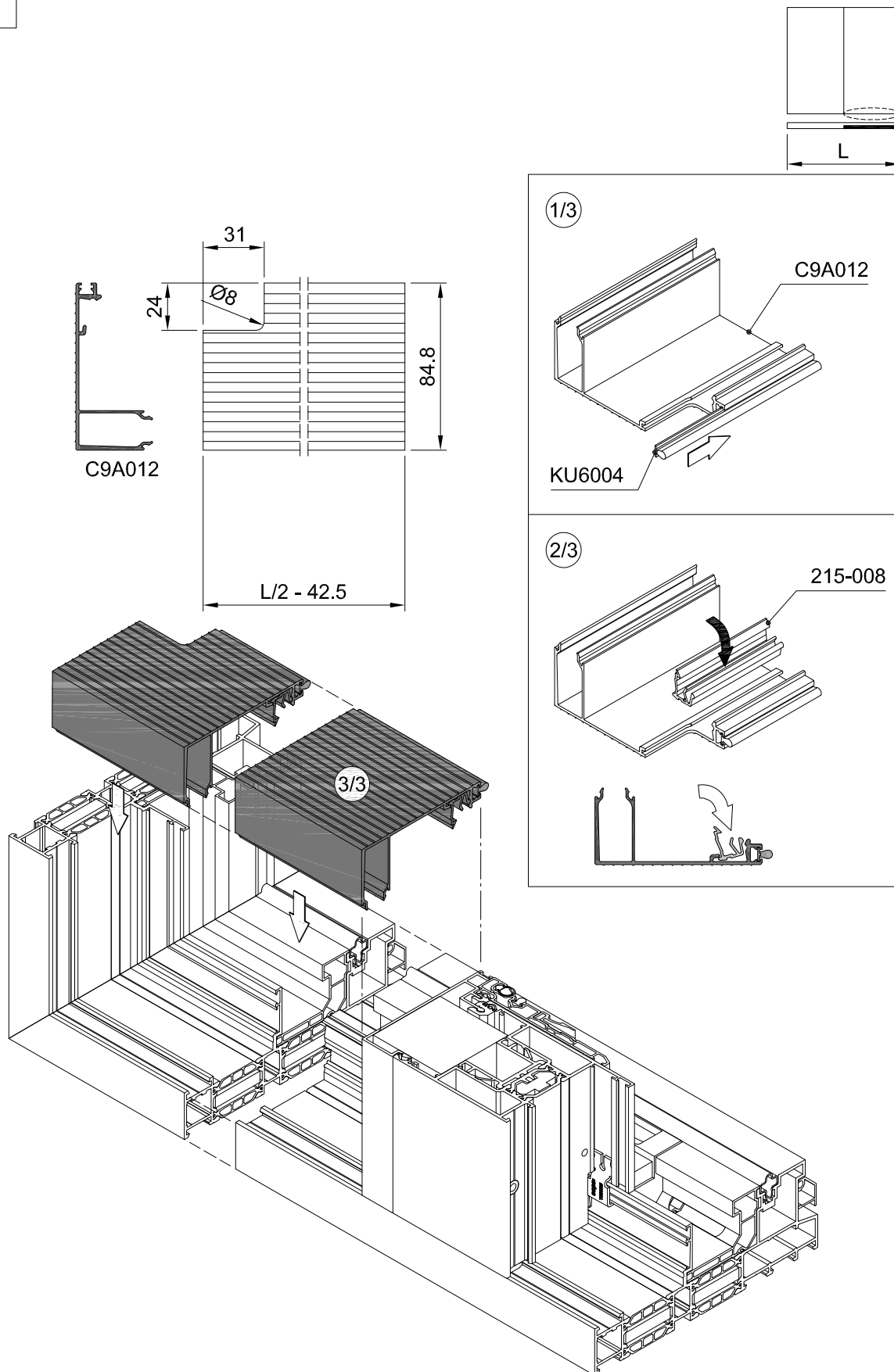

1-BINARIO - ASSEMBLAGGIO CARTELLINA COPERTURA TELAIO C9A012 - SUPERIORE

2 / 5

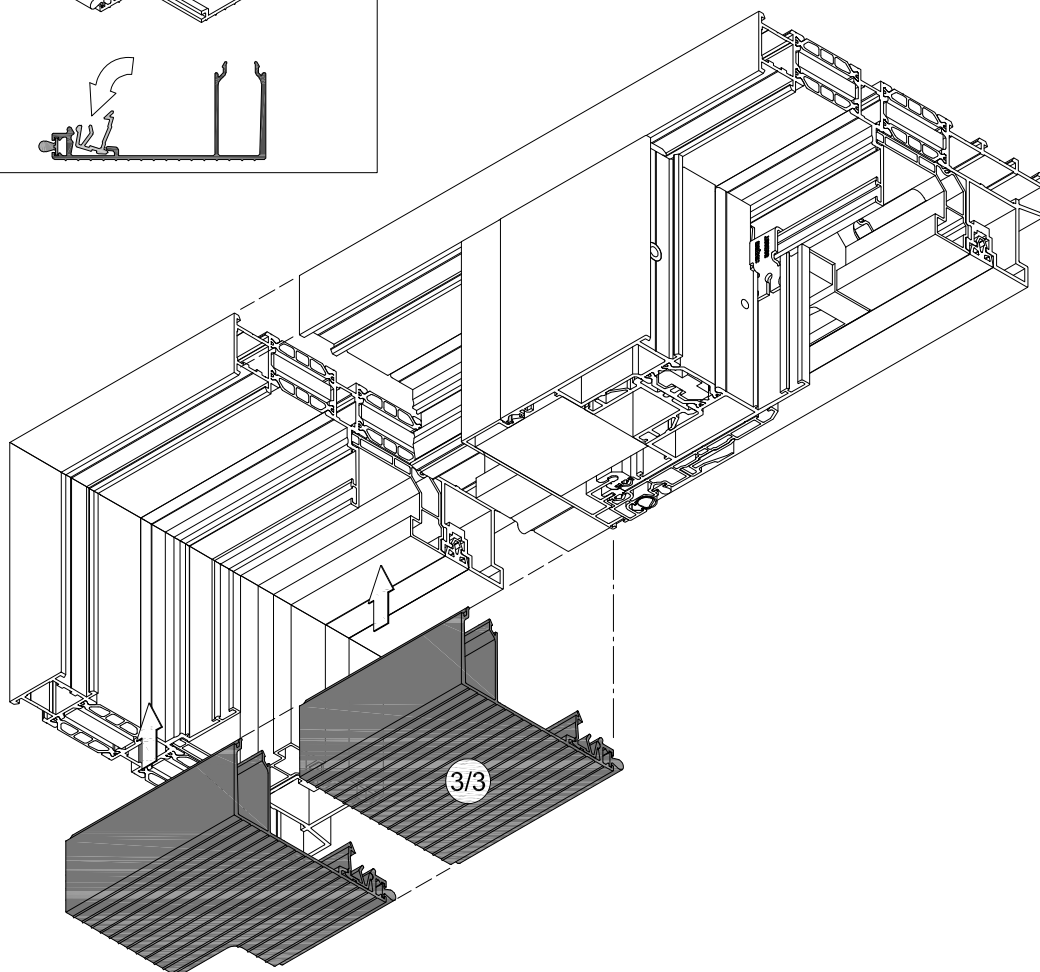
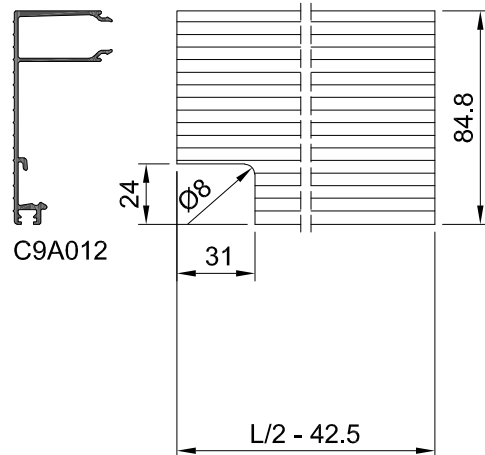
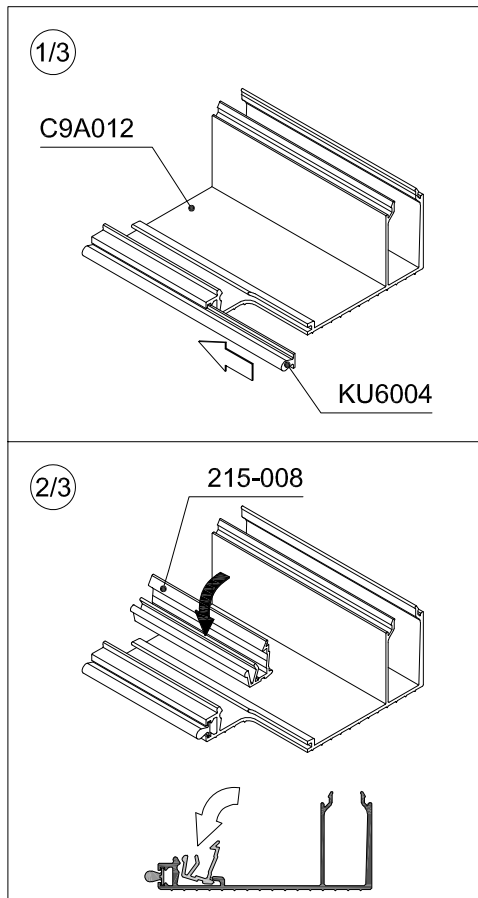



INSTALLAZIONE ANTE SU TELAI

1-BINARIO - ASSEMBLAGGIO CARTELLINA COPERTURA TELAIO C9A012 - LATERALE

3 / 5

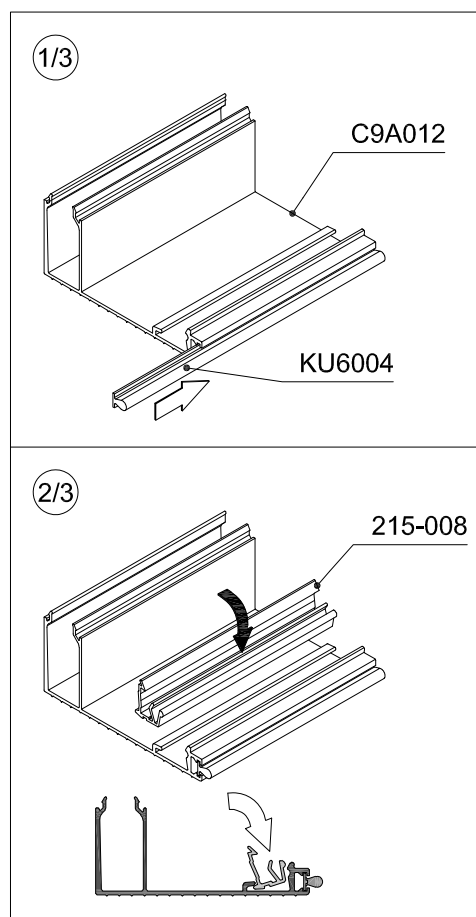
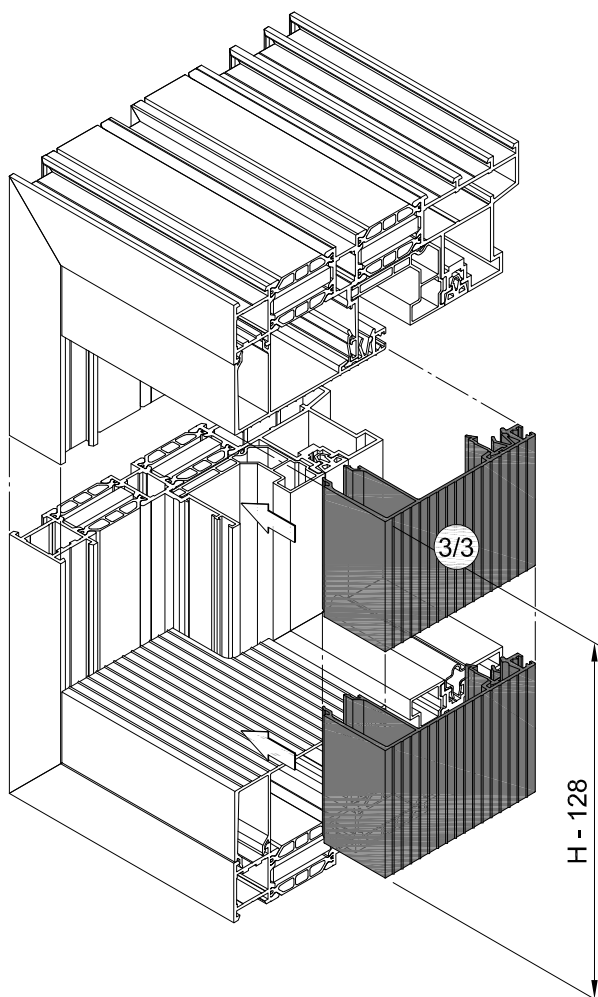
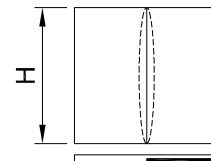

1-BINARIO (C9K010) - ASSEMBLAGGIO ANTA

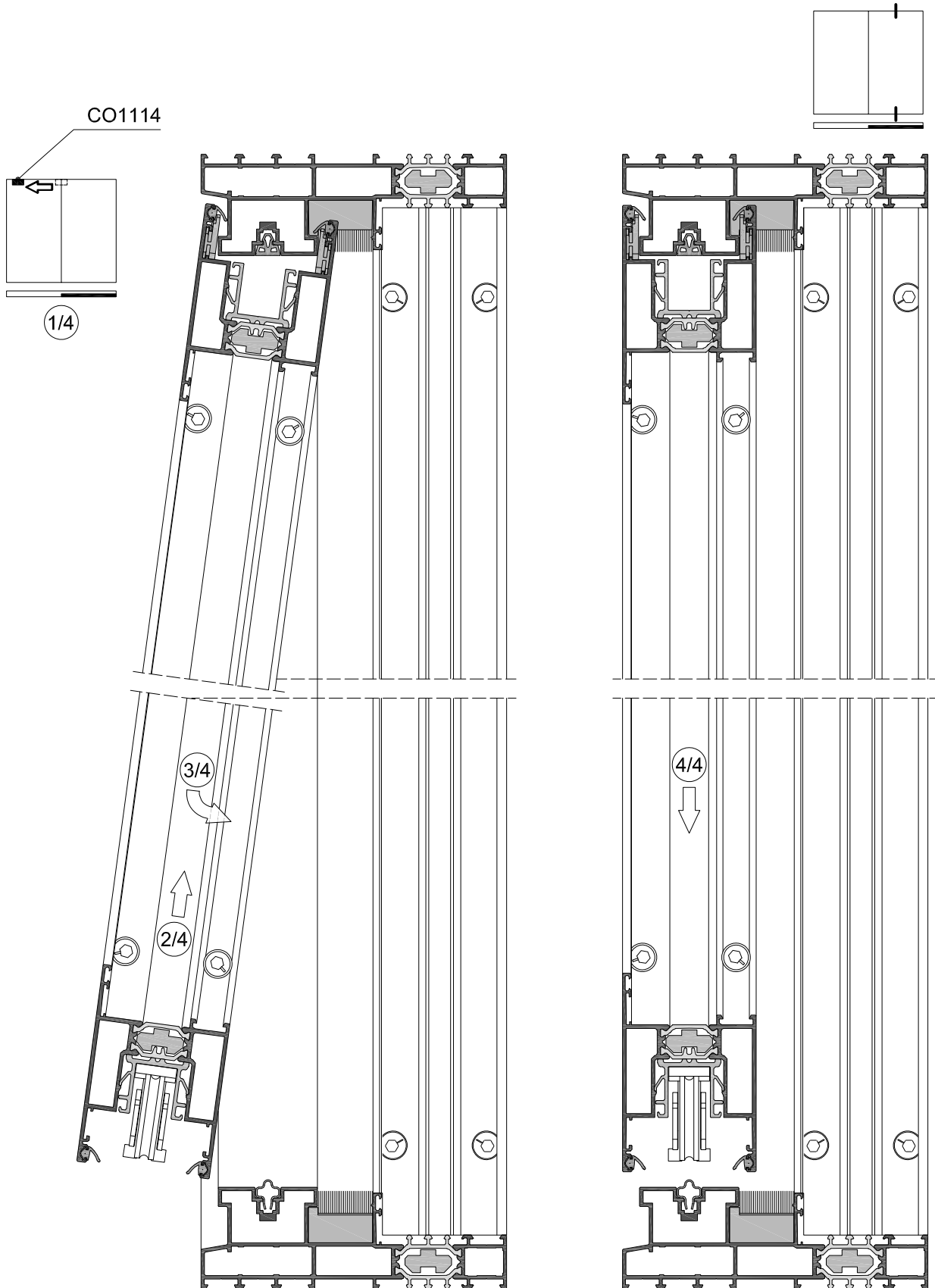



INSTALLAZIONE ANTE SU TELAI

1-BINARIO (C9K010) - FISSAGGIO TAPPO DI TENUTA CENTRALE SUPERIORE

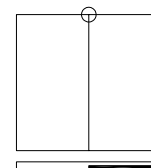

J.2.19

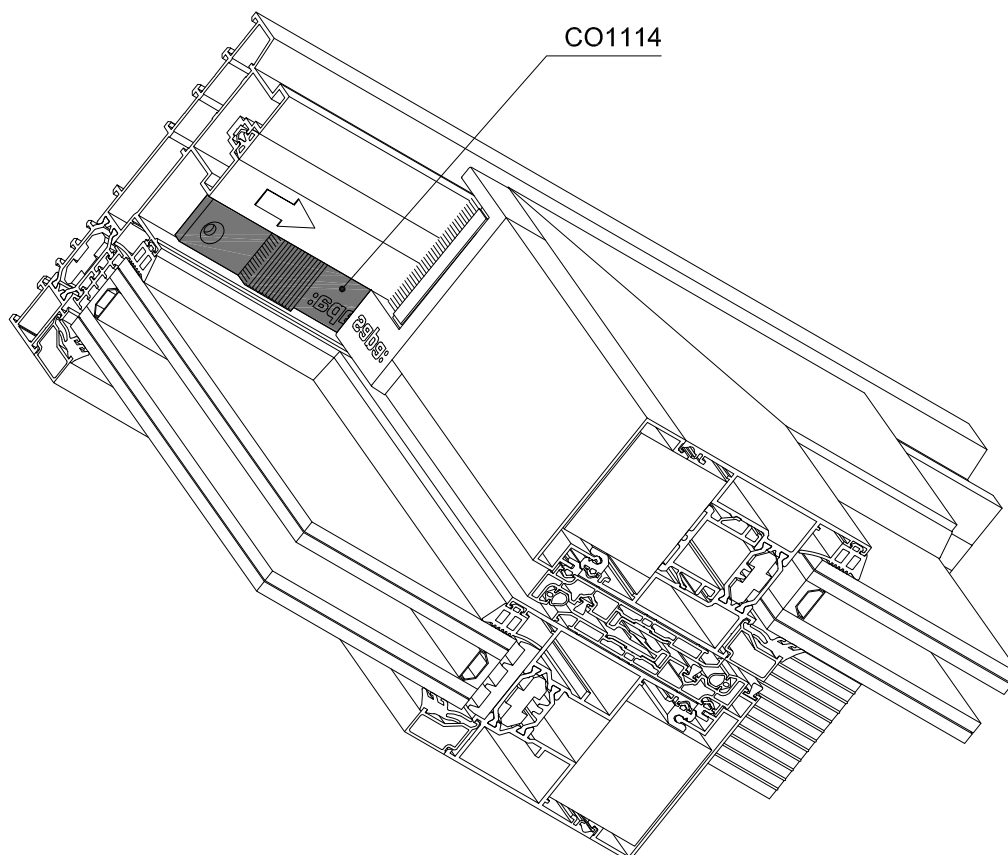
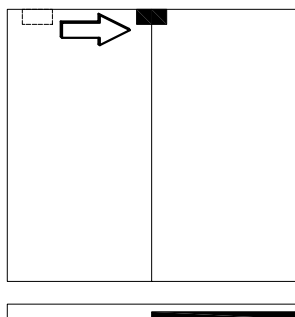

1-BINARIO (C9K010) - C9A010 ASSEMBLAGGIO CARTELLINA COPERTURA TELAIO - INFERIORE

1 / 5

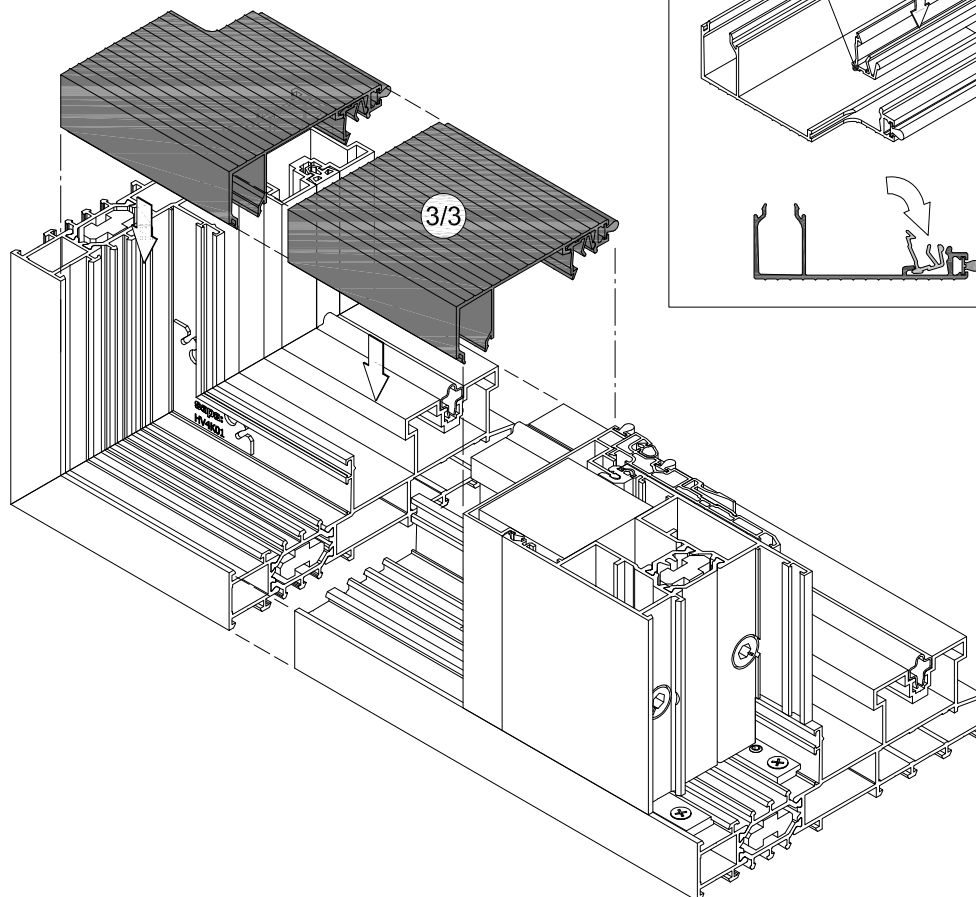
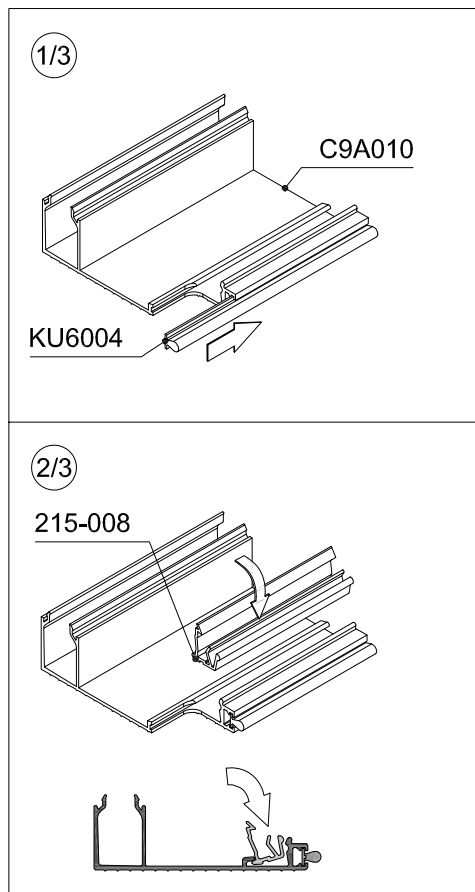
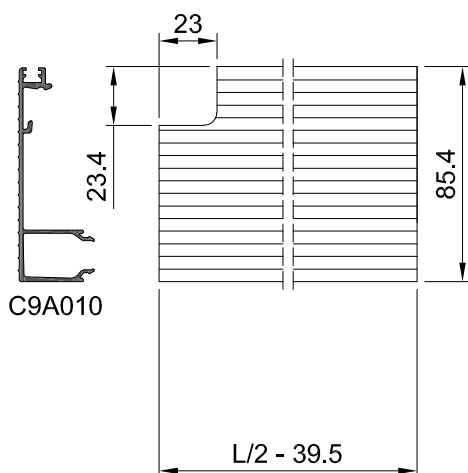
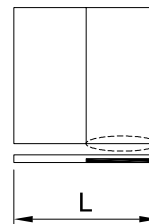



INSTALLAZIONE ANTE SU TELAI

1-BINARIO (C9K010) - C9A010 ASSEMBLAGGIO CARTELLINA COPERTURA TELAIO - SUPERIORE

2 / 5

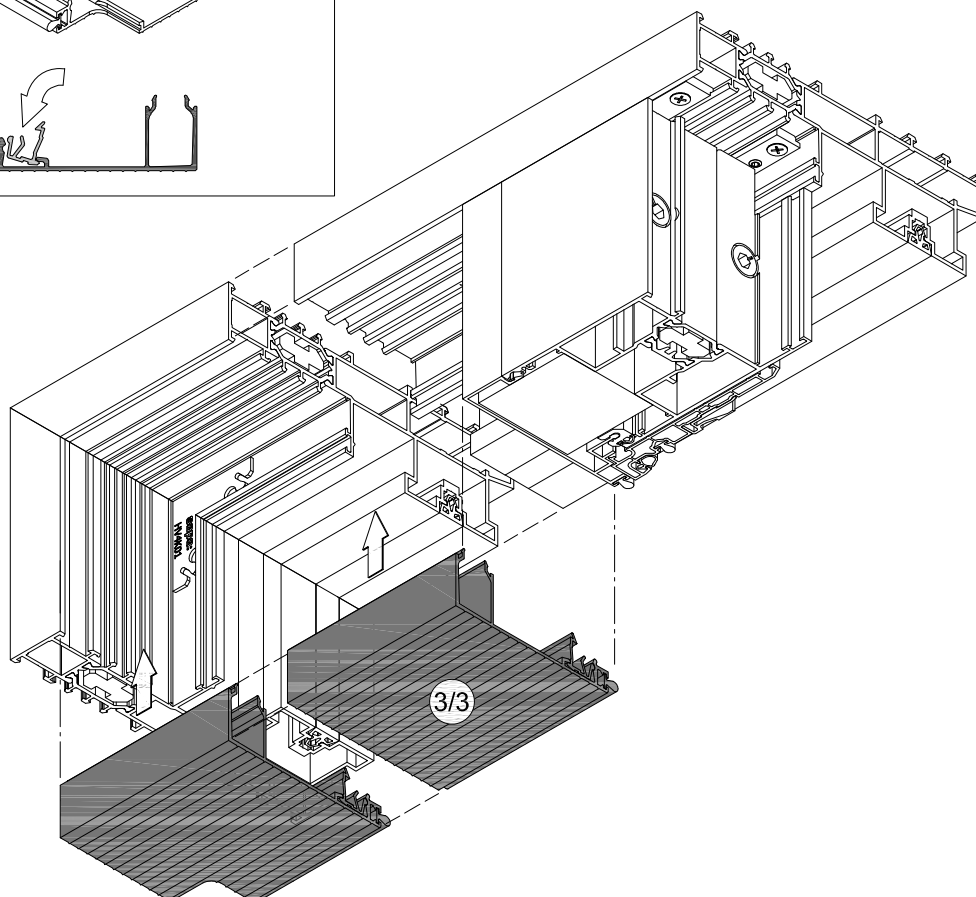
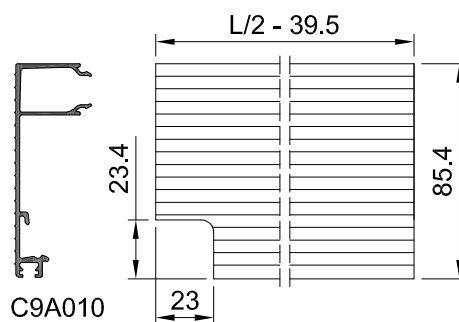
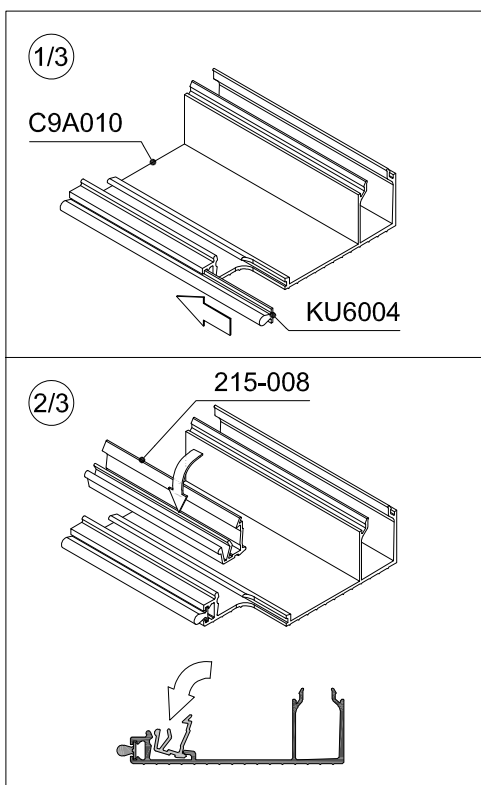
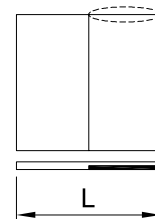

1-BINARIO (C9K010) - C9A010 ASSEMBLAGGIO CARTELLINA COPERTURA TELAIO - LATERALE

3 / 5

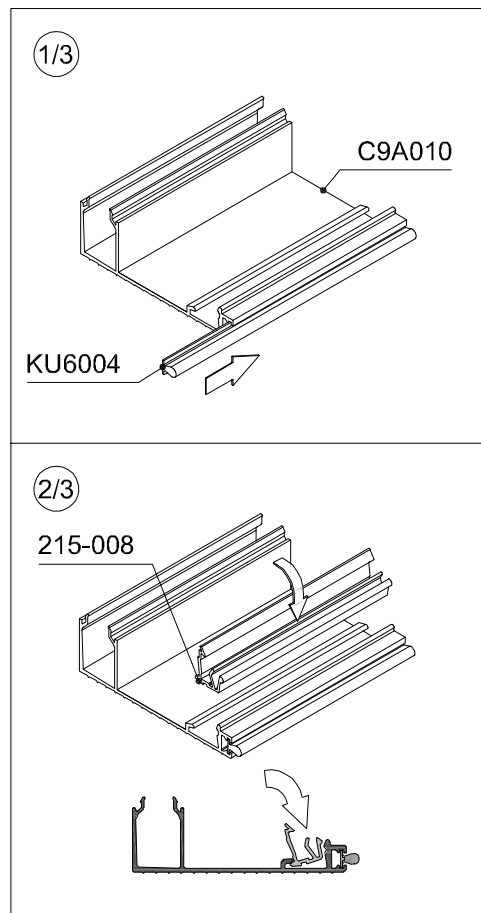
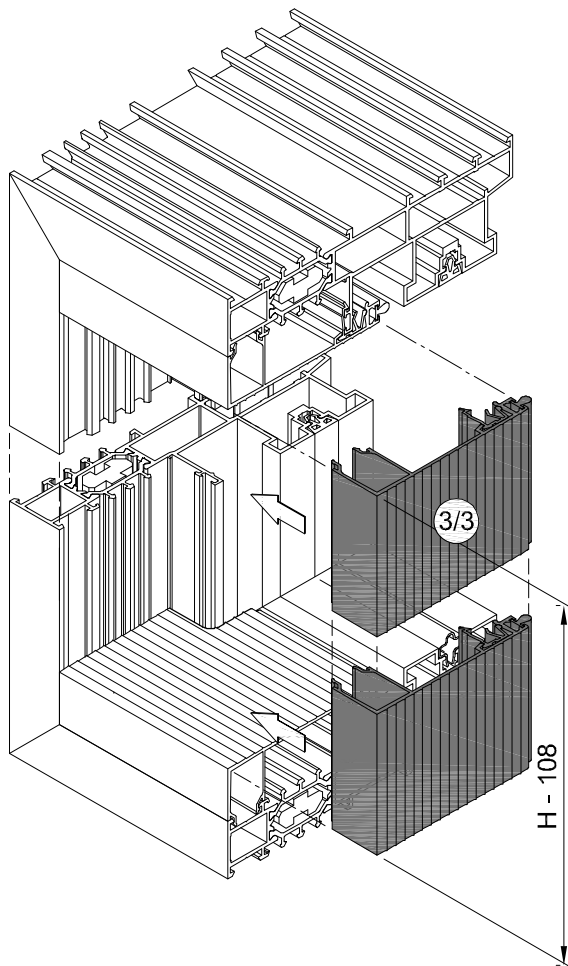
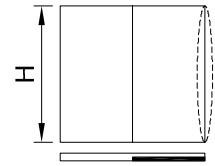



INSTALLAZIONE ANTE SU TELAI

1-BINARIO (C9K010) - C9A010 CARTELLINA COPERTURA TELAIO SCHEMA 4 ANTE - INFERIORE

4 / 5

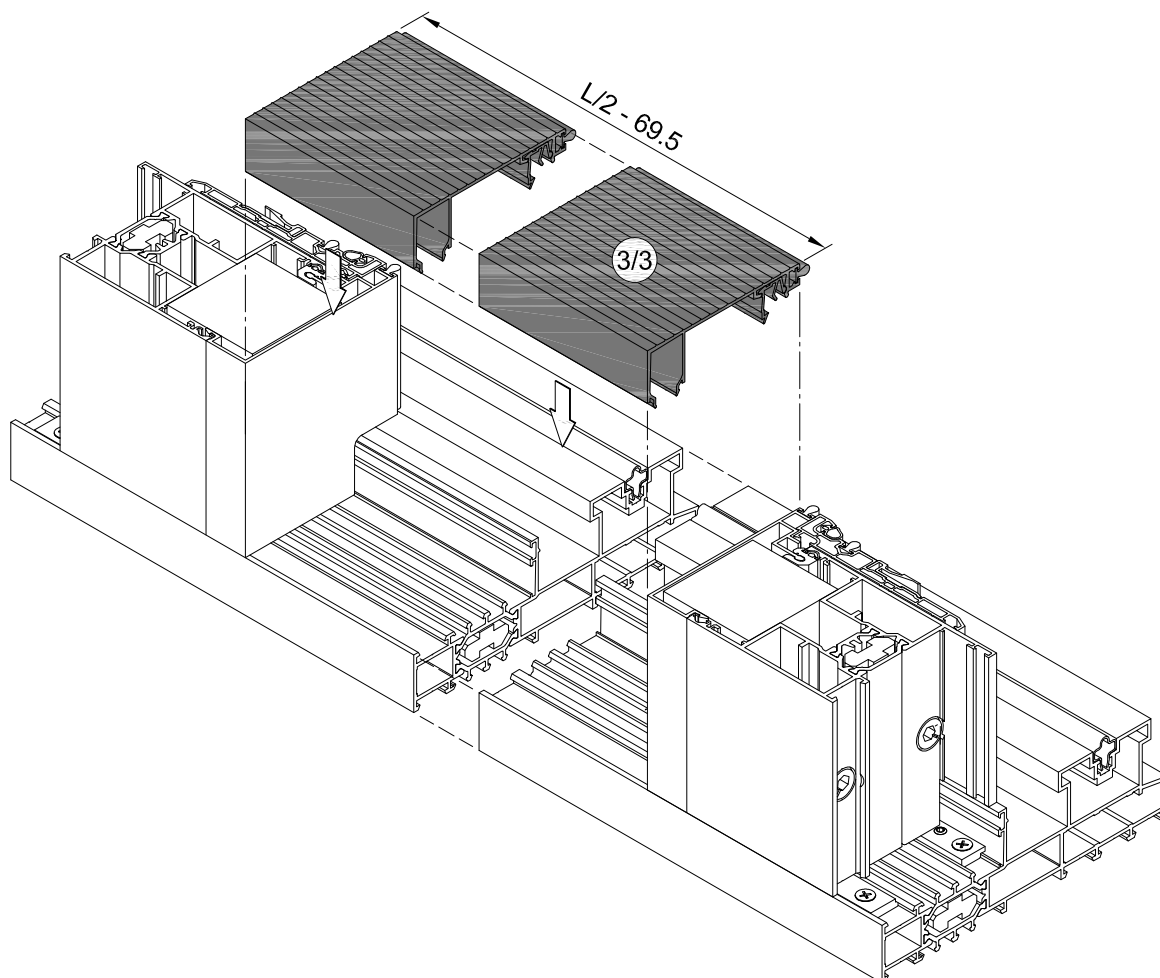
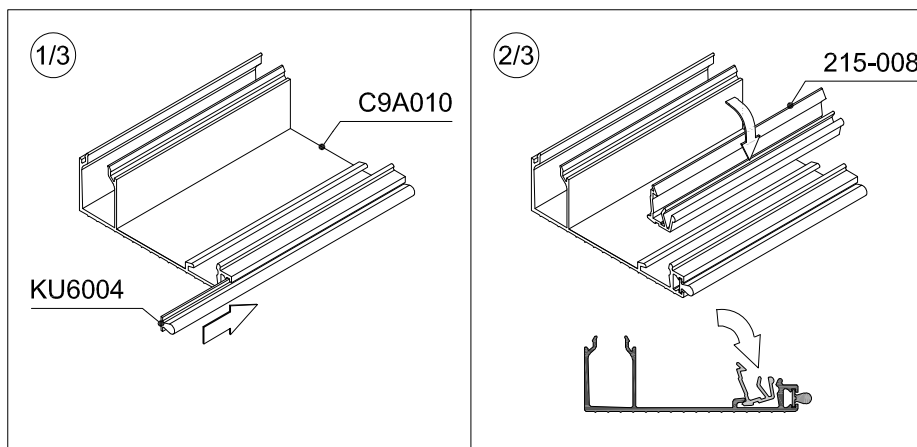
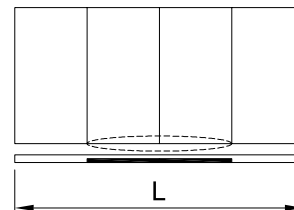

1-BINARIO (C9K010) - C9A010 CARTELLINA COPERTURA TELAIO SCHEMA 4 ANTE - SUPERIORE

5 / 5

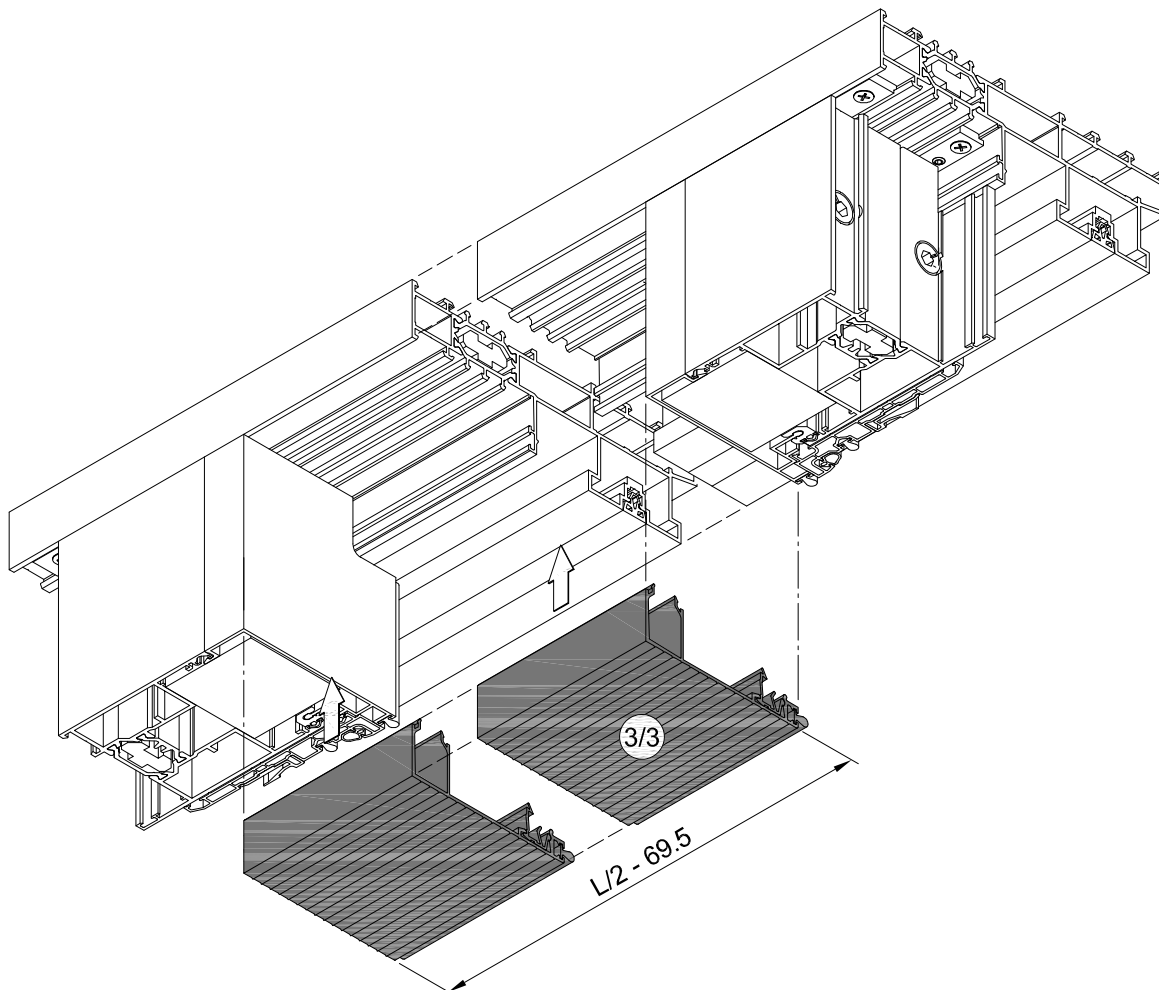
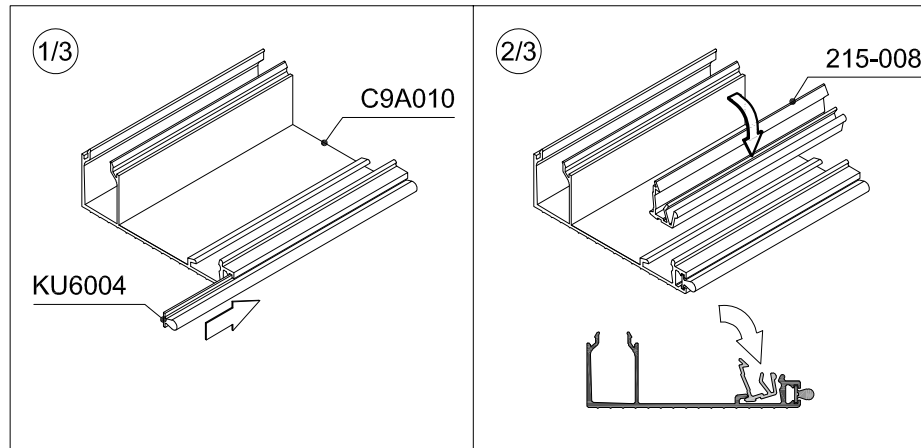
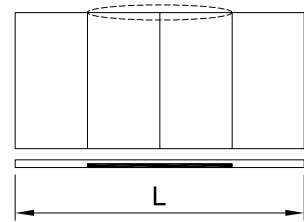



INSTALLAZIONE ANTE SU TELAI

1-BINARIO ANTA FISSA SOGLIA RIBASSATA - UTILIZZO VS5128/VS5129

1 / 11

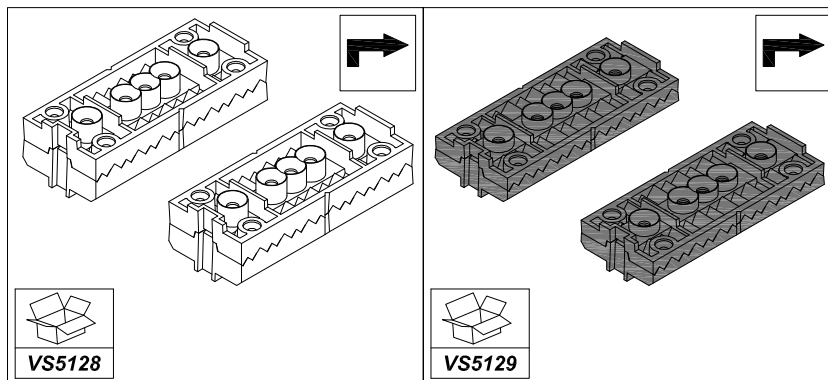

**Uso
STANDARD**

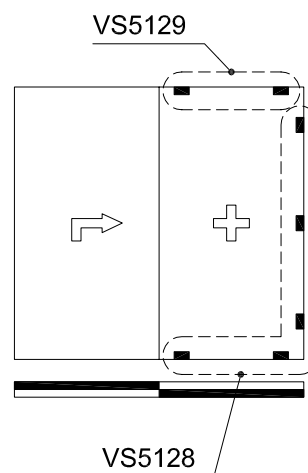

AGGIUSTAMENTI

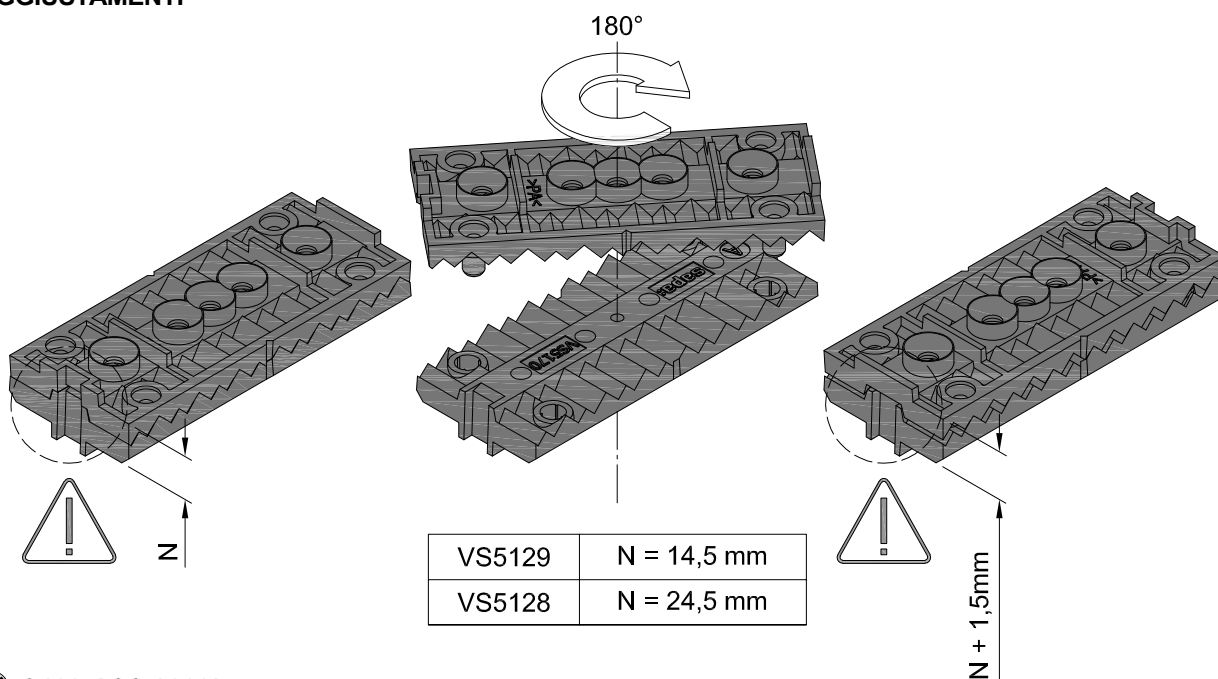

C160-ASS-2289L

1-BINARIO ANTA FISSA SOGLIA RIBASSATA - RIMOZIONE PROFILATO CARTELLINA

2 / 11

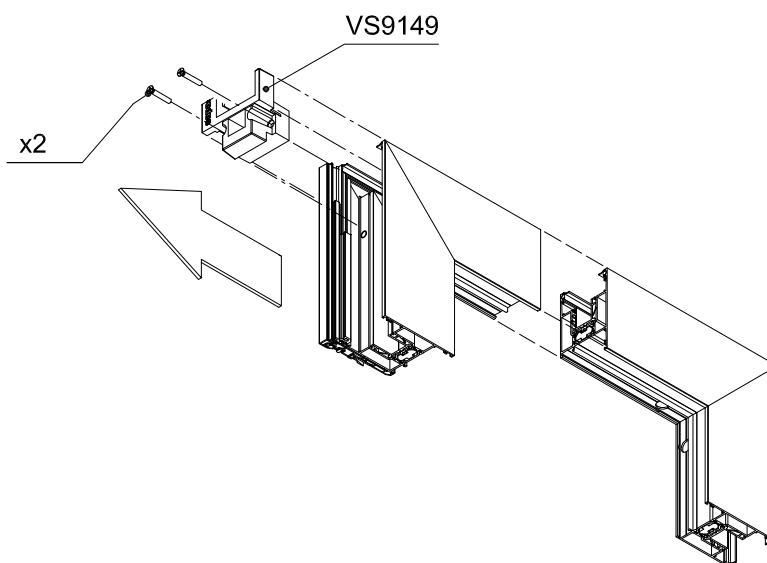
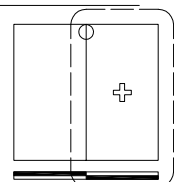
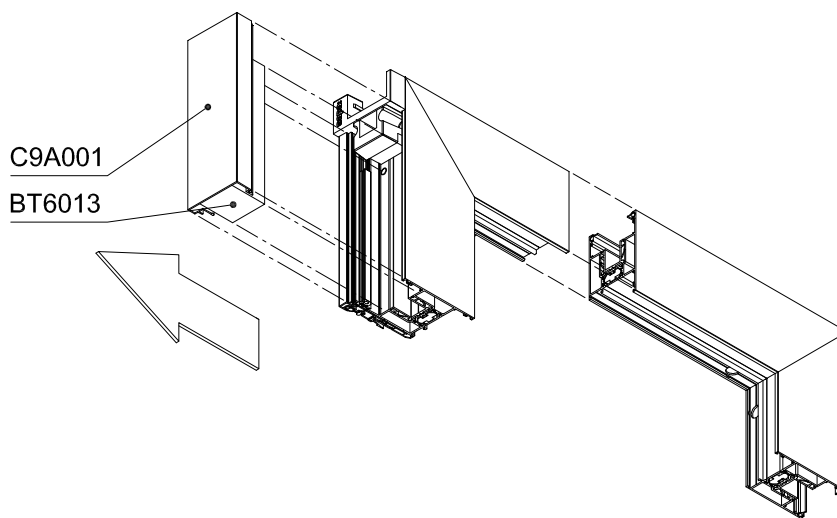
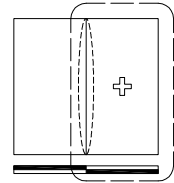



INSTALLAZIONE ANTE SU TELAI

1-BINARIO ANTA FISSA SOGLIA RIBASSATA - INSTALLAZIONE VS5129 E BT6015/BT6014

3 / 11

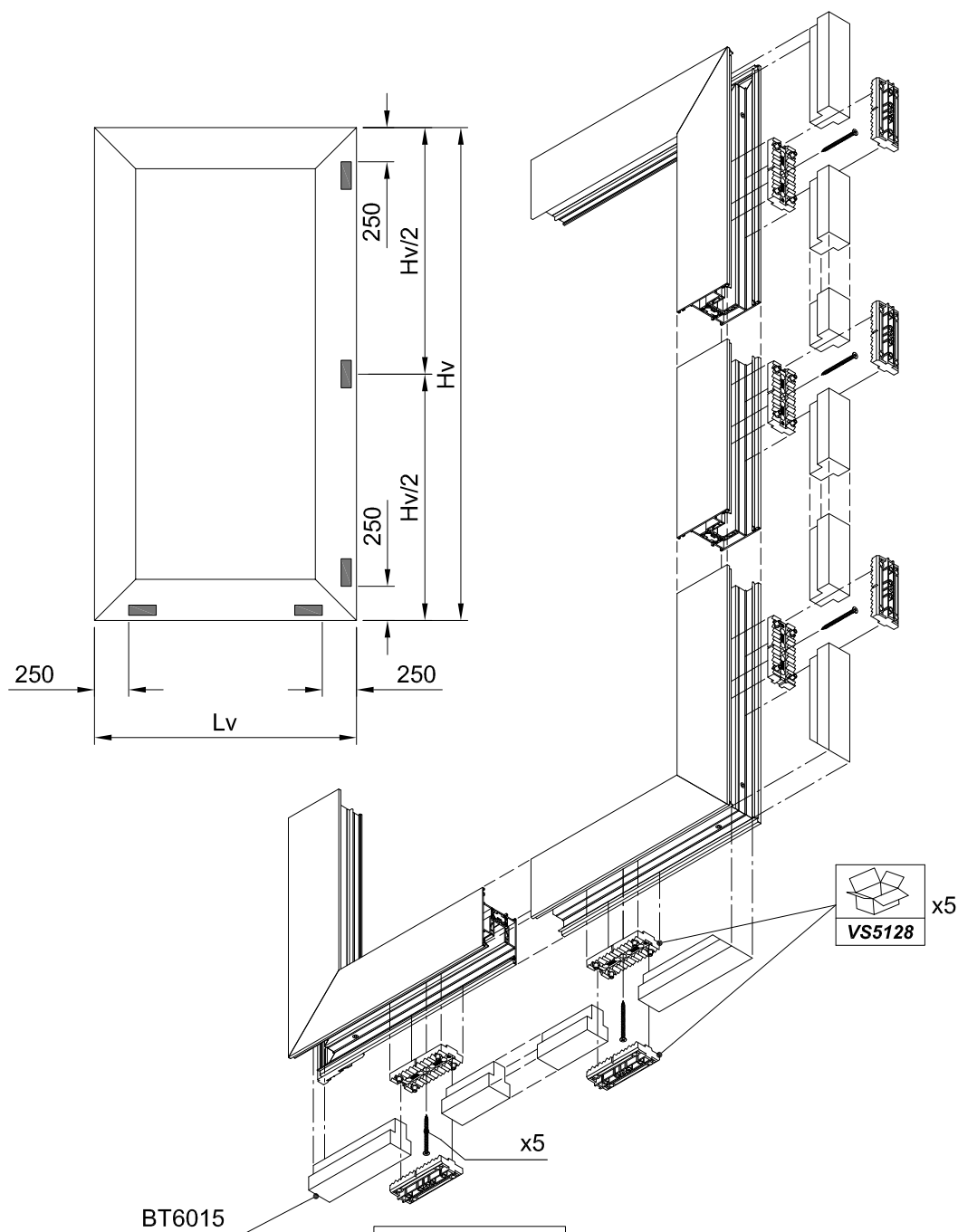
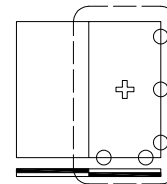

BT6015

	BT6015
SHI	✓
SI	✓
I	x

C160-ASS-2278L

1-BINARIO ANTA FISSA SOGLIA RIBASSATA - BLOCCHI GUIDA FORATURA

4 / 11

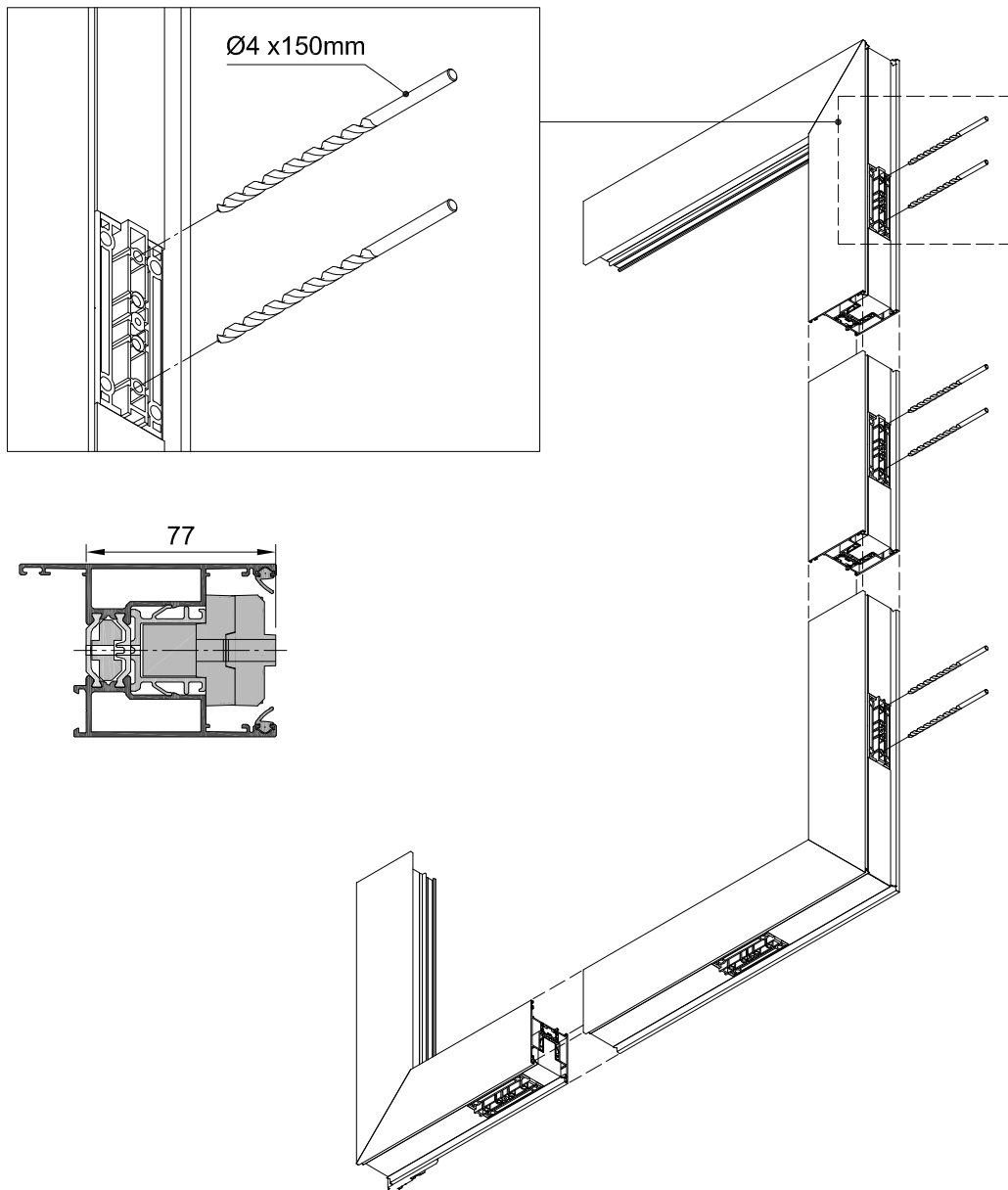
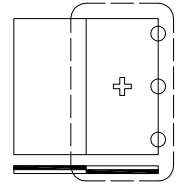



INSTALLAZIONE ANTE SU TELAI

1-BINARIO ANTA FISSA SOGLIA RIBASSATA - INSTALLAZIONE VS5129 E BT6026/BT6027

5 / 11

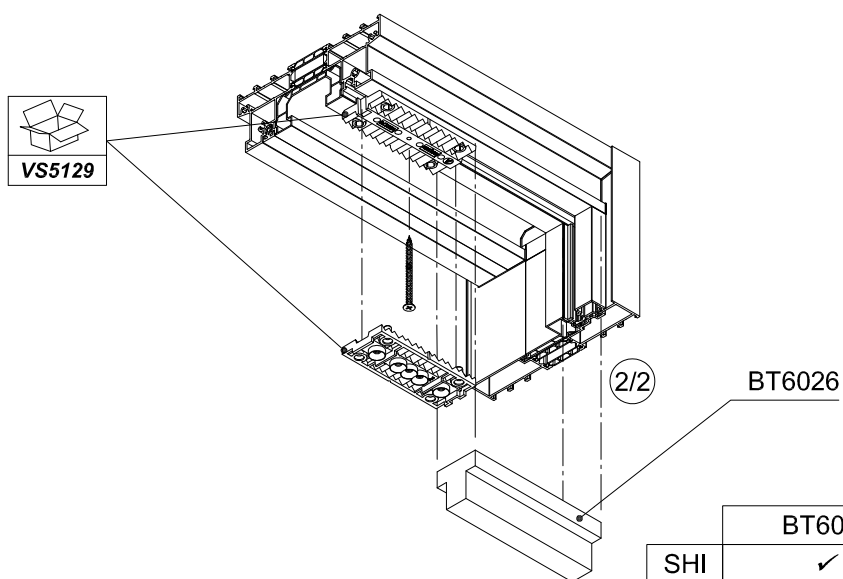
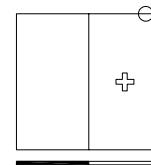
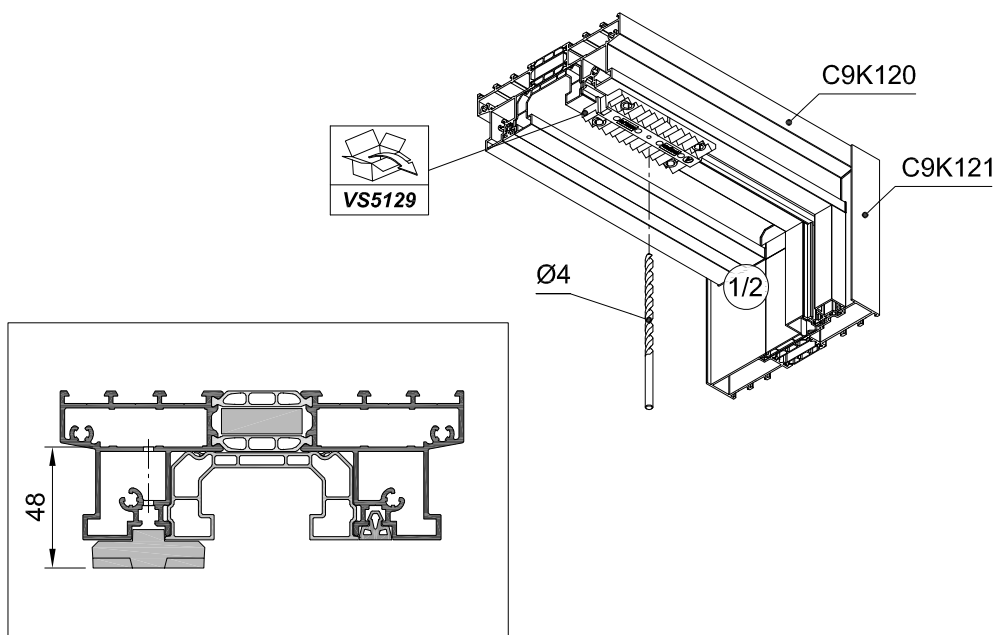
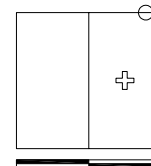

	BT6026
SHI	✓
SI	✓
I	x

C160-ASS-2281L

1-BINARIO ANTA FISSA SOGLIA RIBASSATA - POSIZIONAMENTO ANTA FISSA SUL TELAI

6 / 11

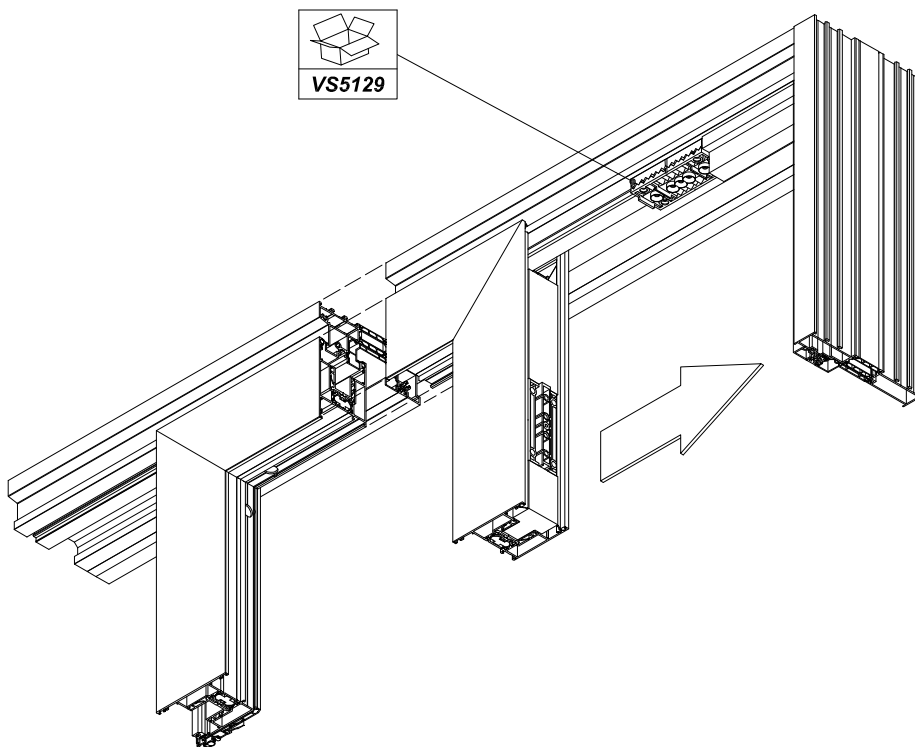
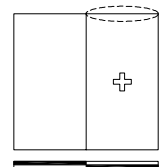
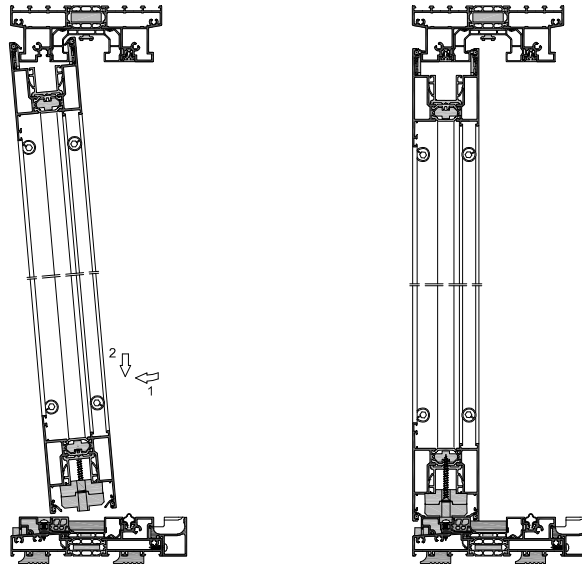
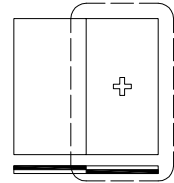

 **C160-ASS-2282L**



INSTALLAZIONE ANTE SU TELAI

1-BINARIO ANTA FISSA SOGLIA RIBASSATA - BT6026/BT6027 E VS5129 SUPERIORE

7 / 11

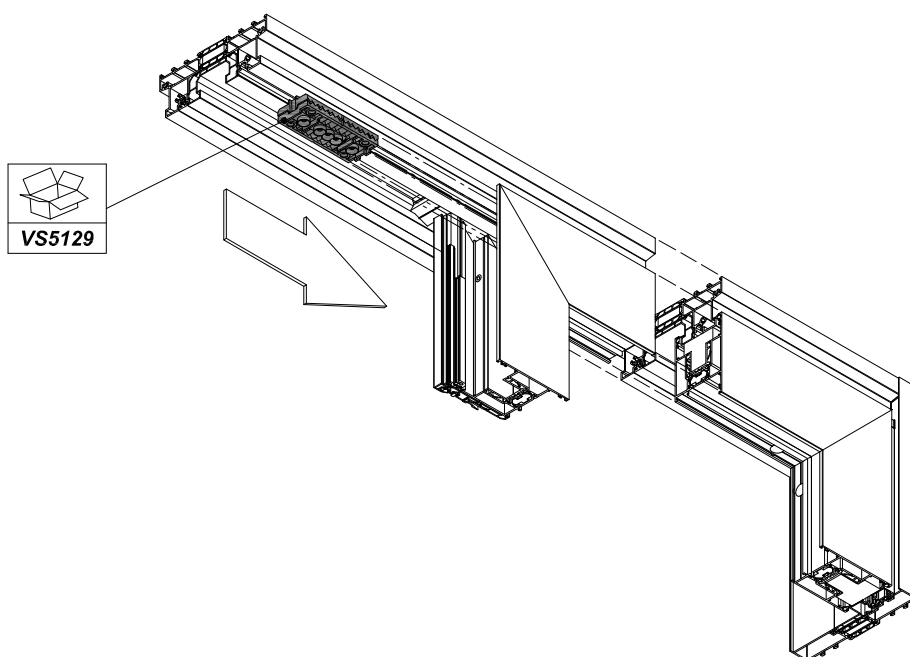
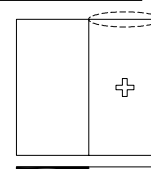
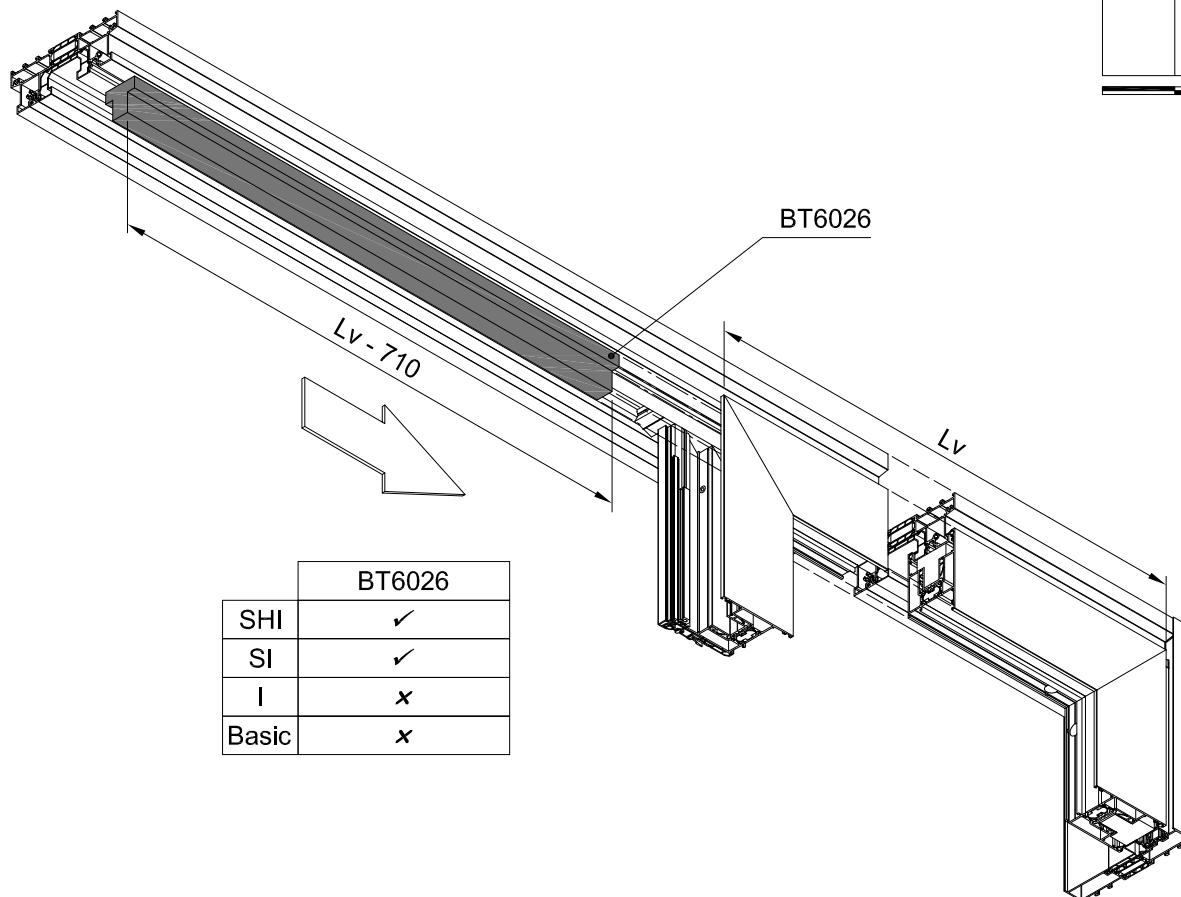
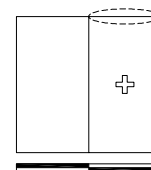

C160-ASS-2283L

1-BINARIO ANTA FISSA SOGLIA RIBASSATA - FISSAGGIO CON SCZ617/SCZ834

8 / 11

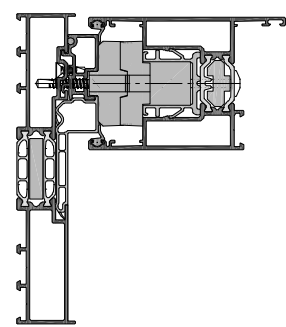
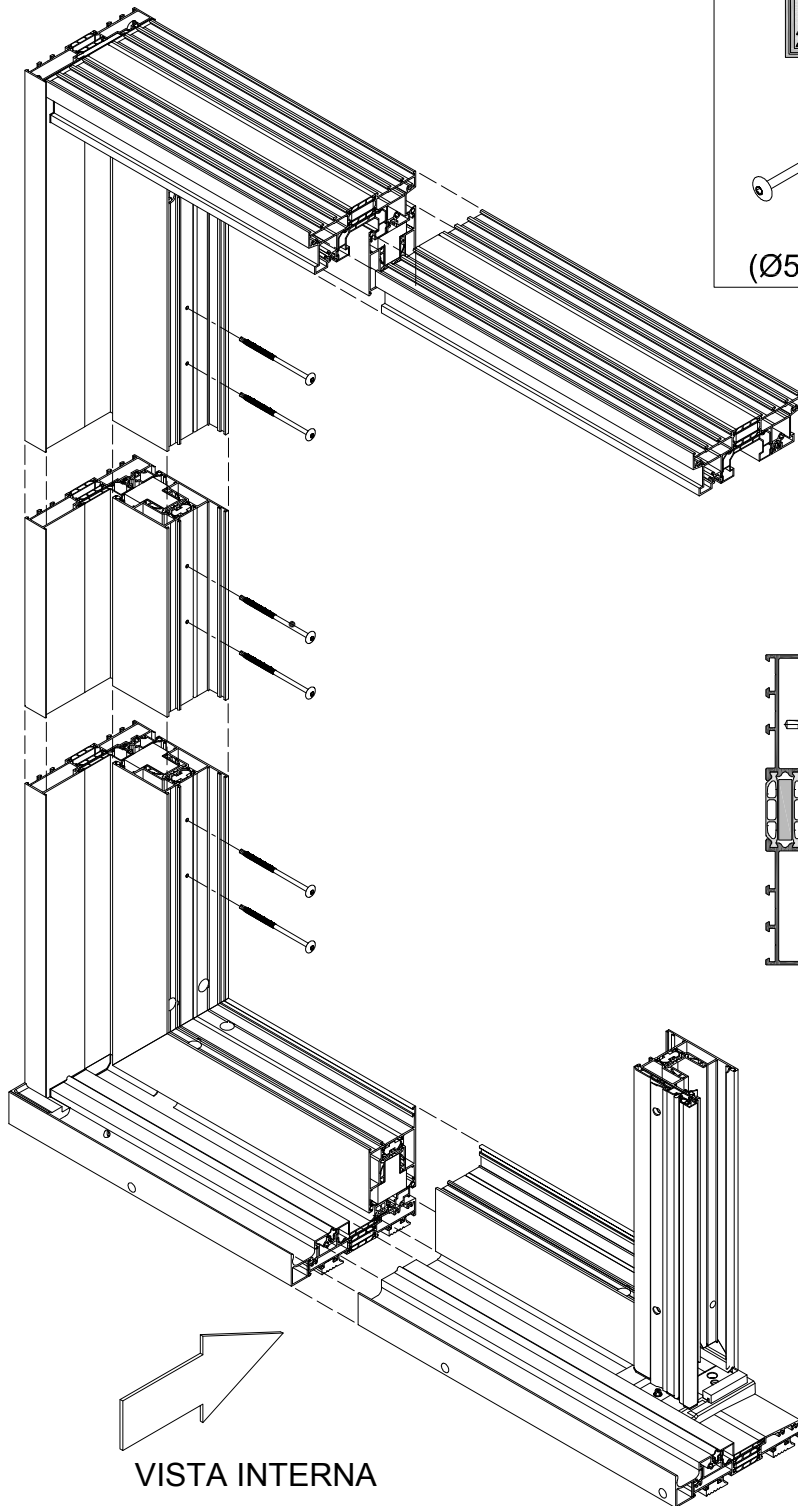
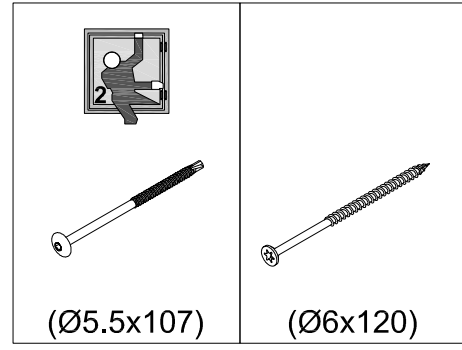
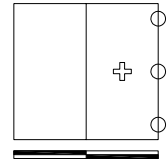

 C160-ASS-2284



INSTALLAZIONE ANTE SU TELAI

1-BINARIO ANTA FISSA SOGLIA RIBASSATA - FISSAGGIO SUPERIORE ANT SCZ617/SCZ834

9 / 11

VISTA INTERNA

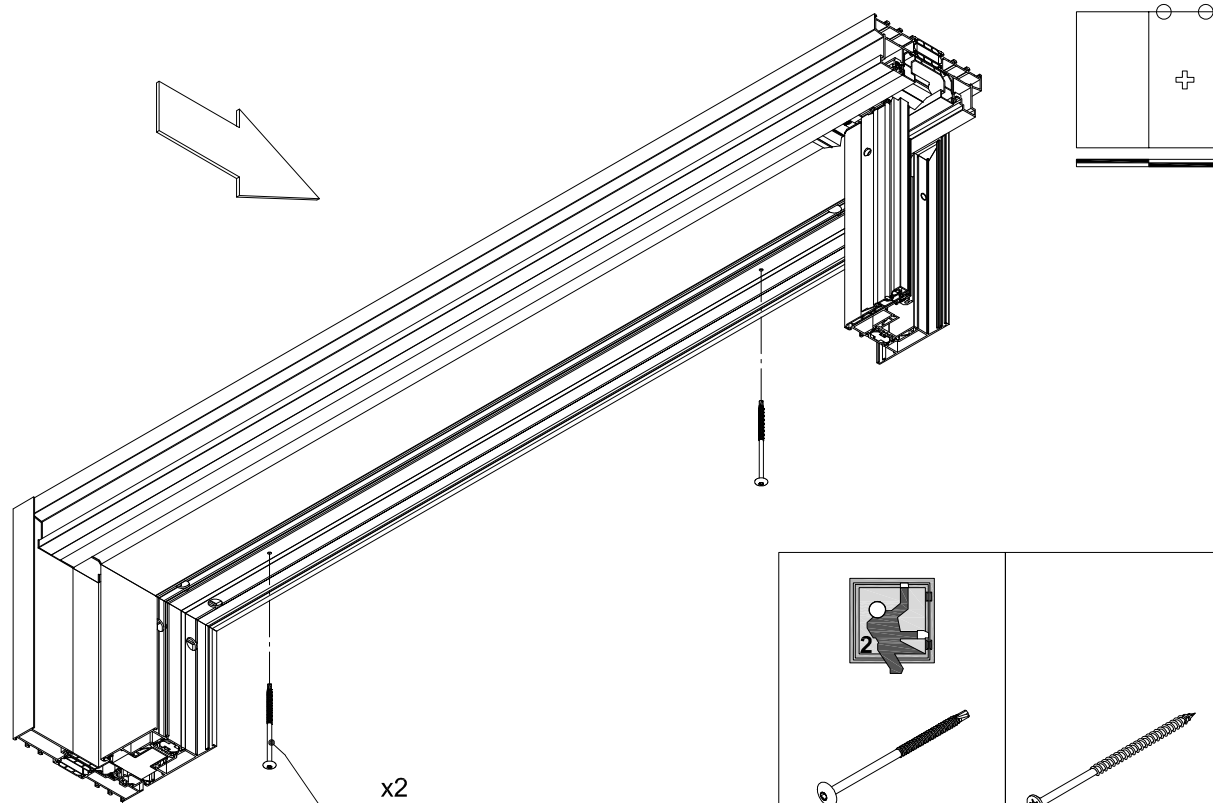
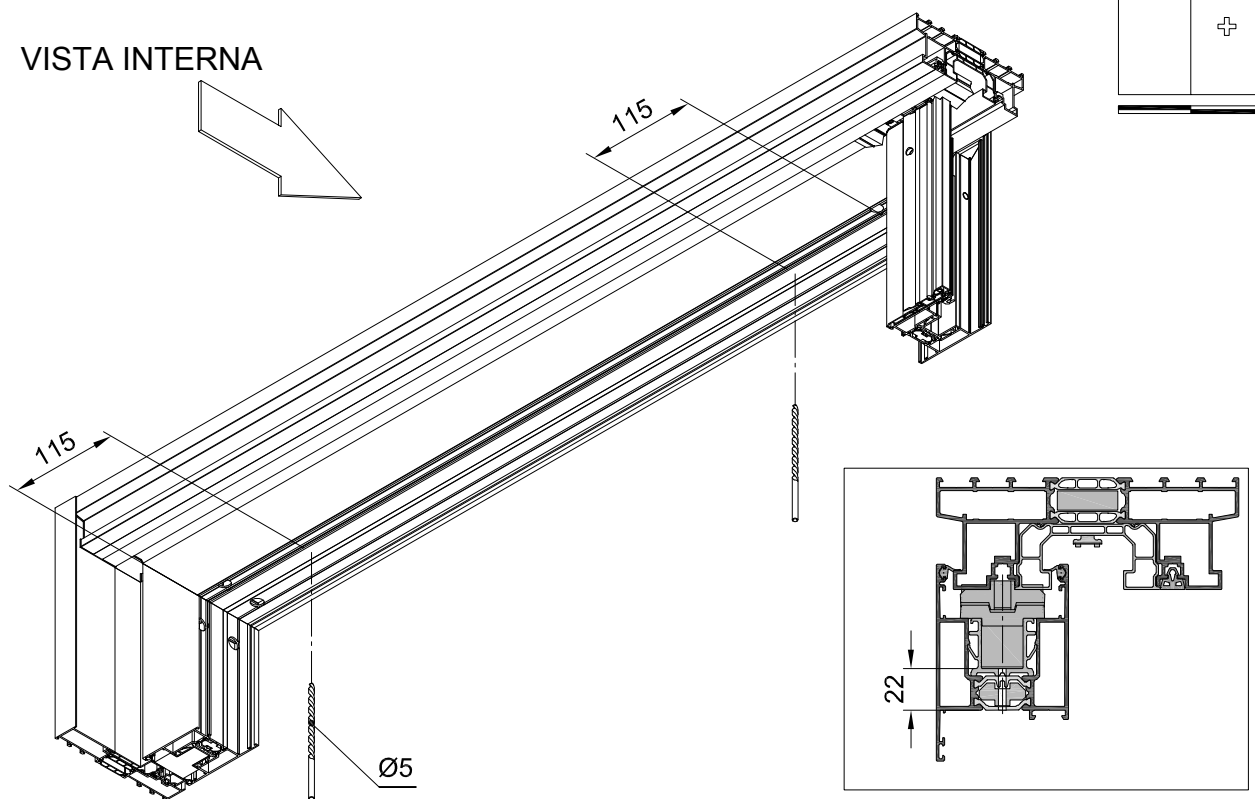

C160-ASS-2285

1-BINARIO ANTA FISSA SOGLIA RIBASSATA - TAPPO DI TENUTA ADDIZIONALE SUPERIORE DELL'ANTA

10 / 11

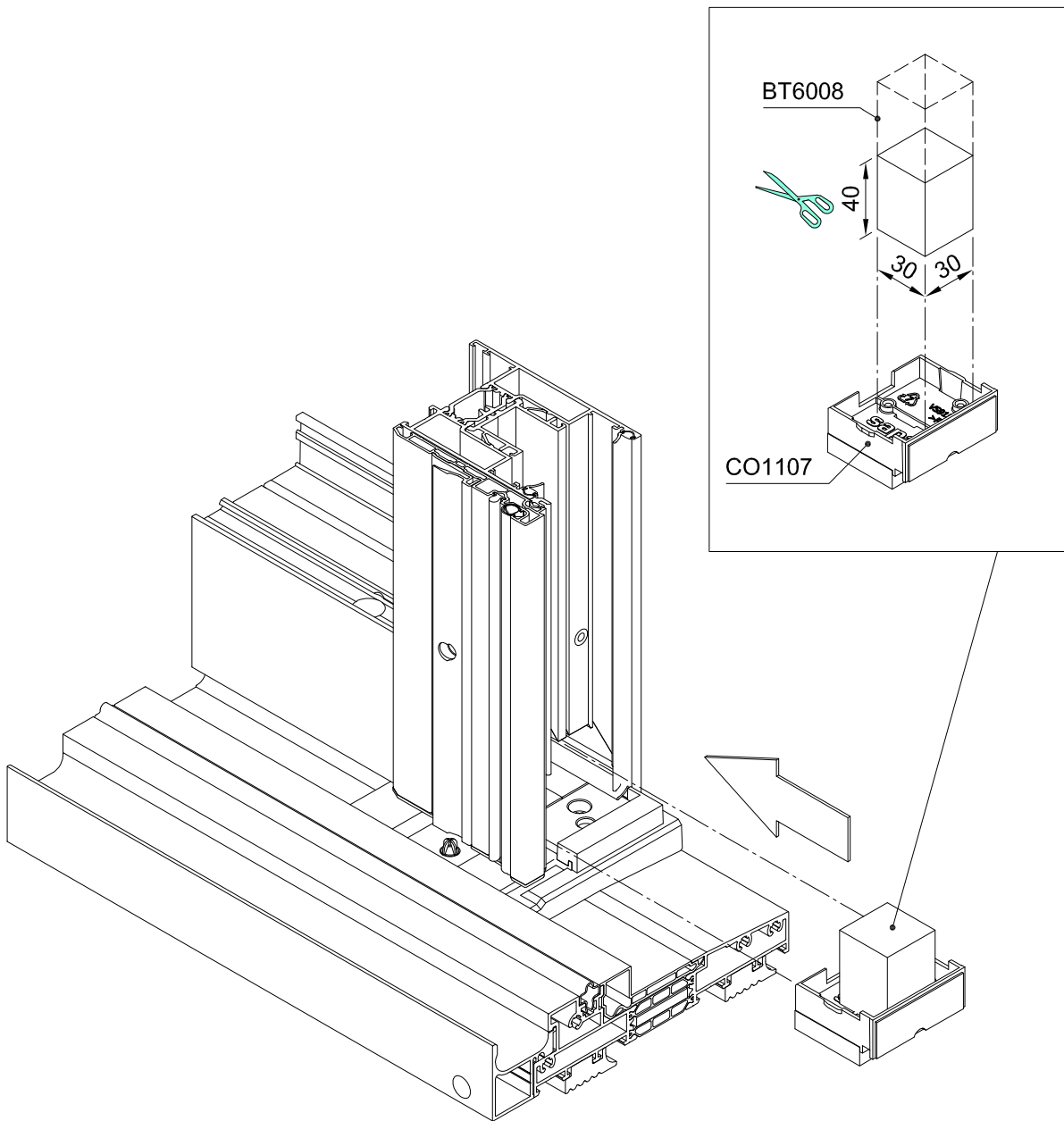
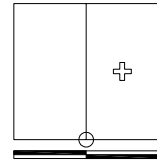



INSTALLAZIONE ANTE SU TELAI

1-BINARIO ANTA FISSA SOGLIA RIBASSATA - TAPPO DI TENUTA SUPERIORE E CARTELLINA ANTA

11 / 11

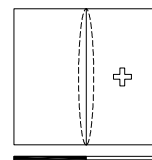
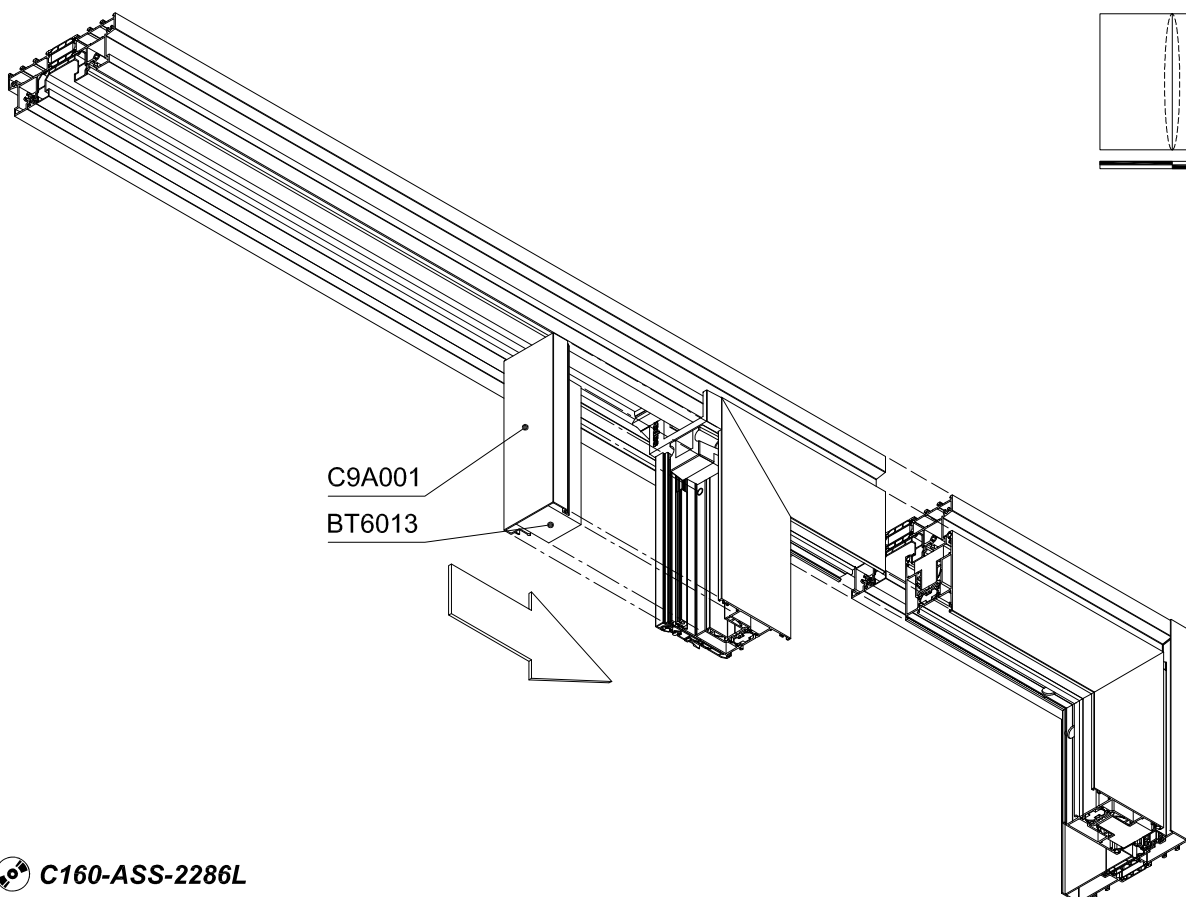
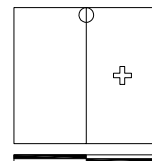
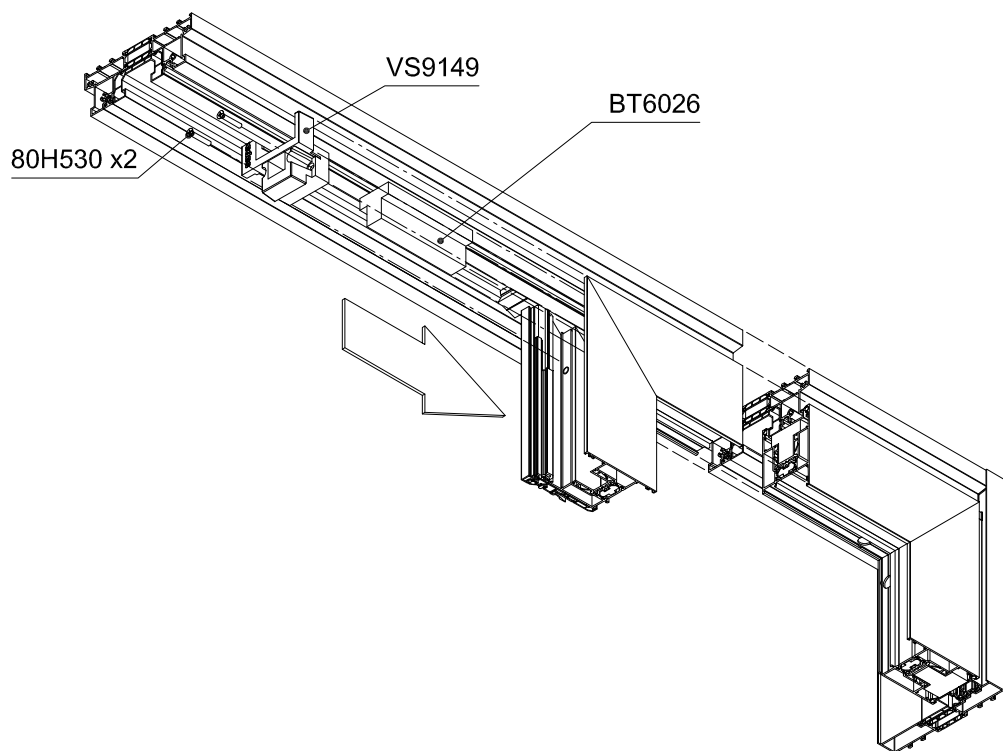

1-BINARIO ANTA FISSA SOGLIA RIBASSATA - POSIZIONAMENTO ANTA APRIBILE SUL TELAI

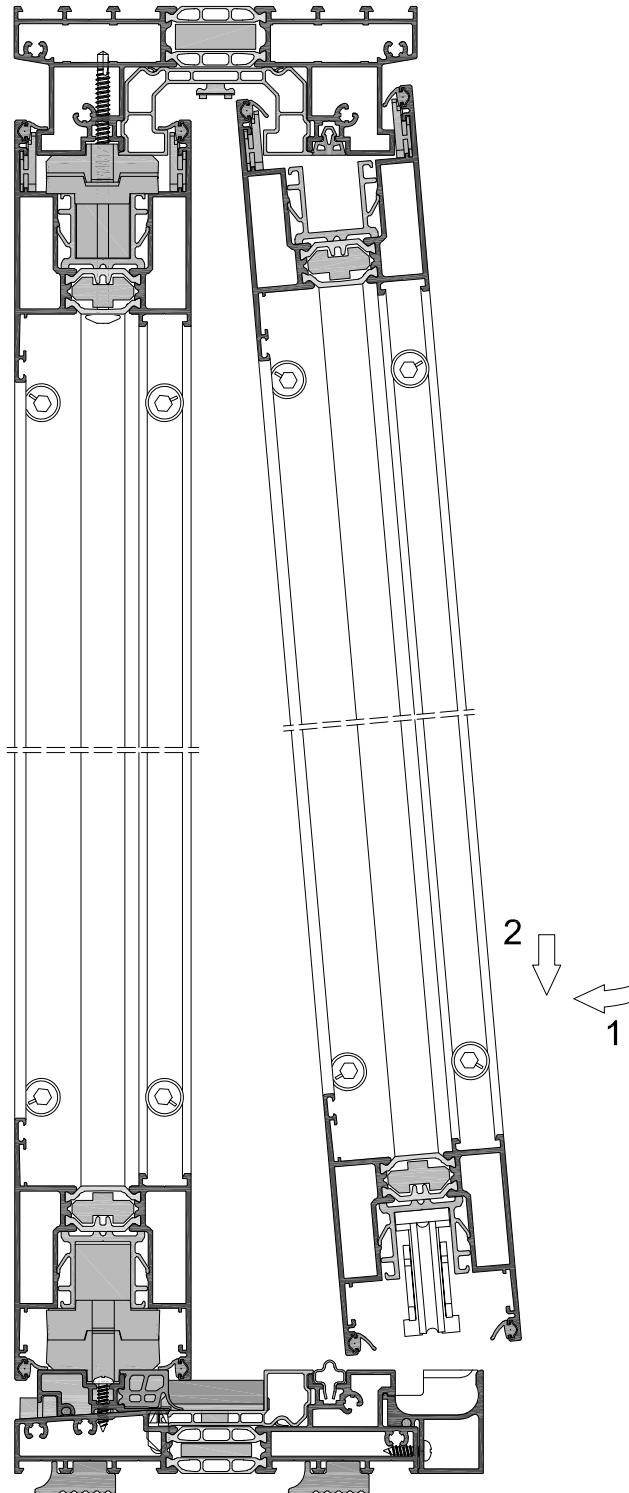
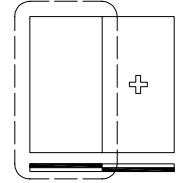



INSTALLAZIONE ANTE SU TELAI

1-BINARIO ANTA FISSA SOGLIA RIBASSATA - ASSEMBLAGGIO TAPPO DI TENUTA SUPERIORE

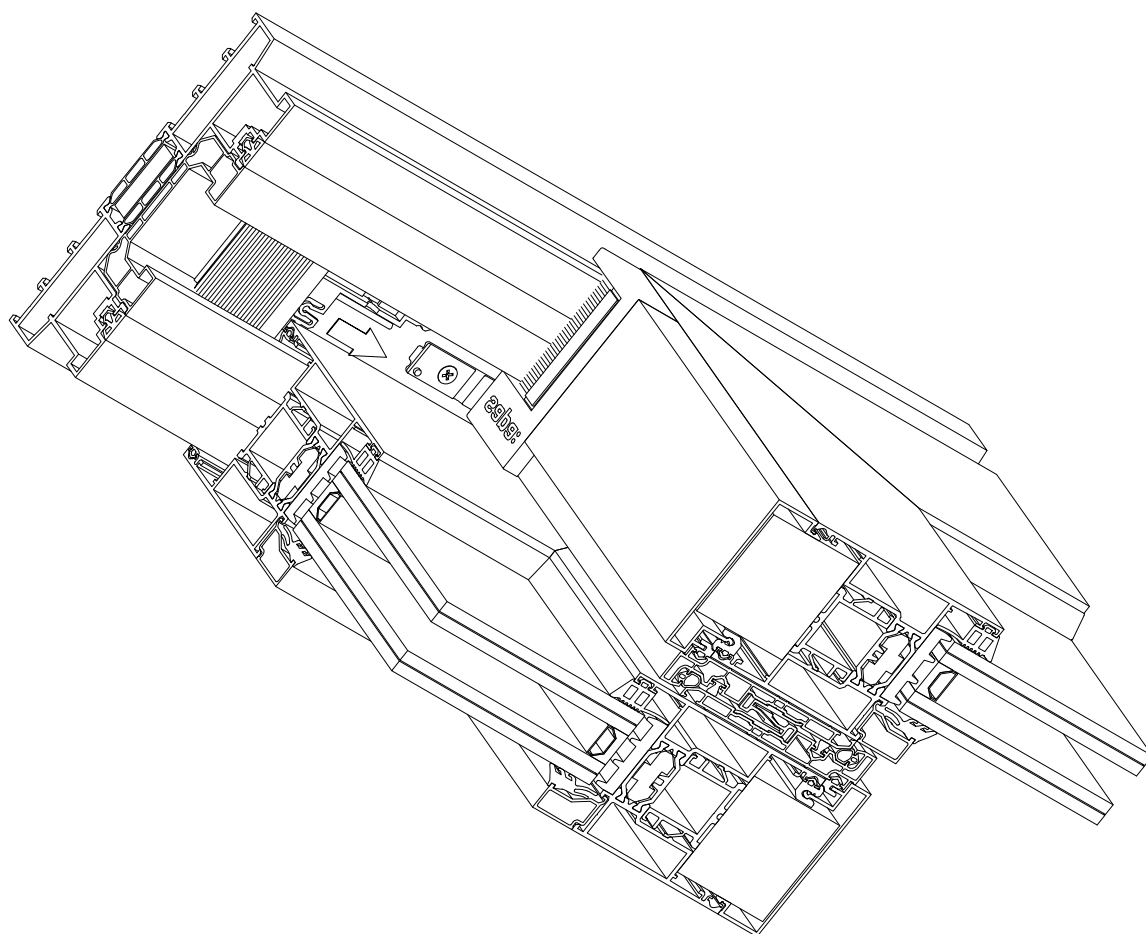
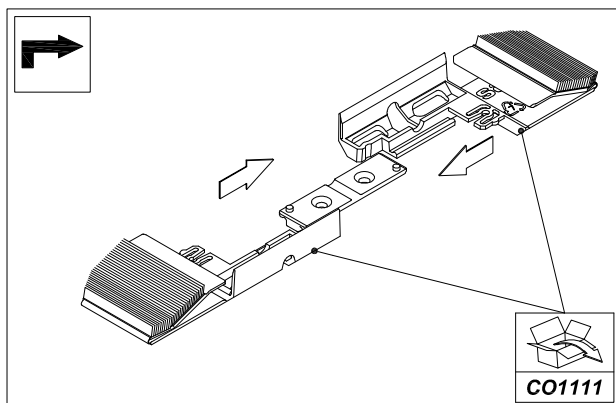
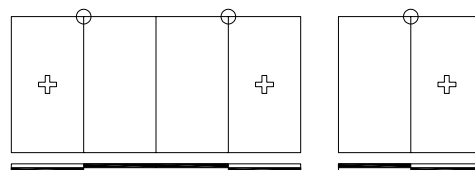

ASSEMBLAGGIO FINE CORSA

C9V001+KU2027
C9V051+KU2027
C9V004

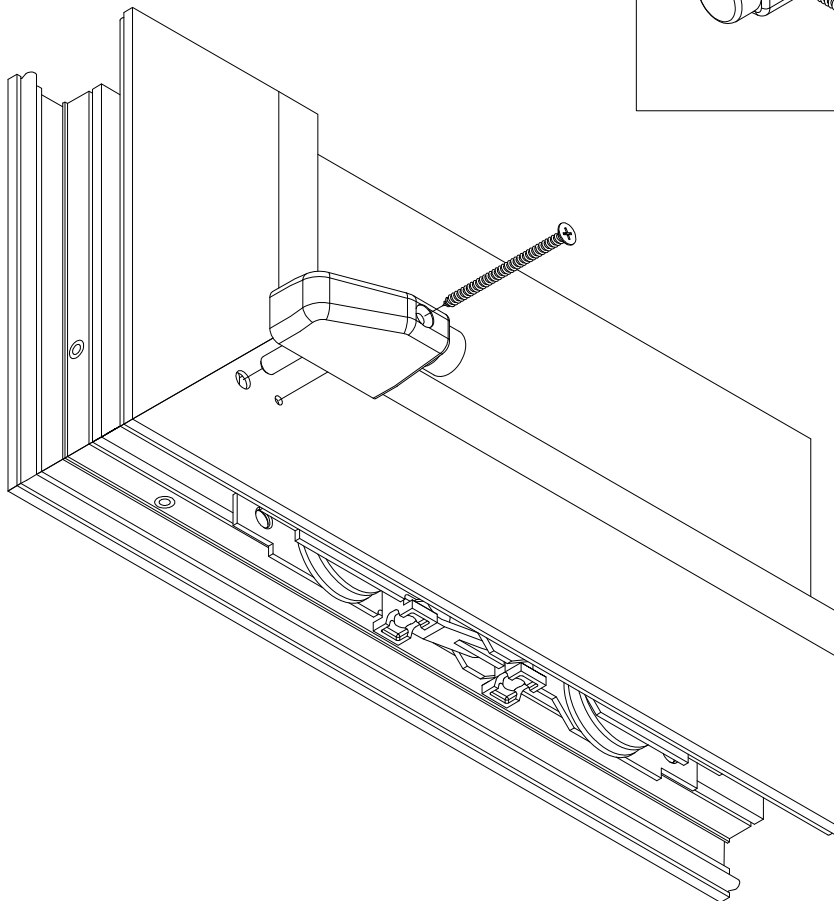
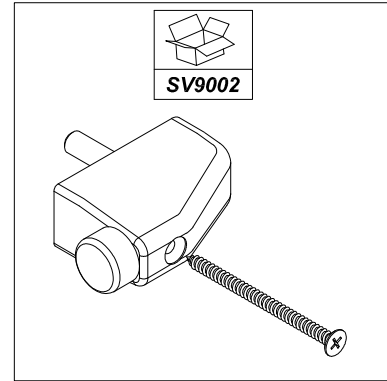
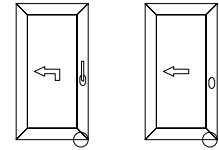



OPERAZIONI FINITURA ANTE

CONTENUTO

Operazioni di finitura anta.....	J.11.1
Contenuto.....	J.11.1
Anta passiva schema 4 ante - tappo di tenuta.....	J.11.2
Anta passiva schema 4 ante - fissaggio tappo di tenuta.....	J.11.3
Anta passiva schema 4 ante - posizionamento incontri di chiusura.....	J.11.4
Anta passiva schema 4 ante - installazione guarnizione di finitura RU9704.....	J.11.5
Inserimento finale tappo di tenuta ante alzante-scorrevole.....	J.11.6

ANTA PASSIVA SCHEMA 4 ANTE - TAPPO DI TENUTA

1 / 2

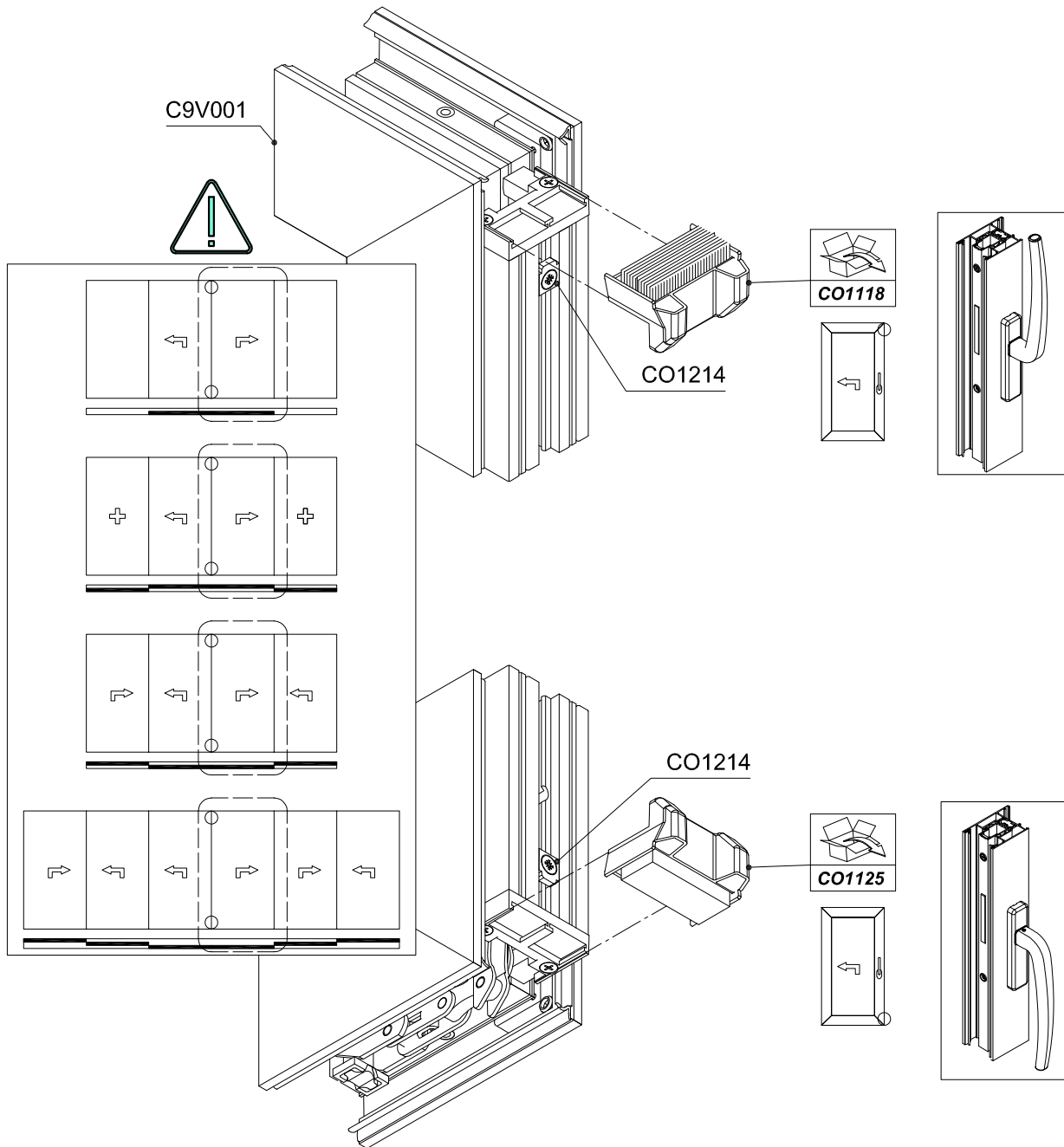
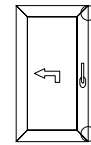



OPERAZIONI FINITURA ANTE

ANTA PASSIVA SCHEMA 4 ANTE - FISSAGGIO TAPPO DI TENUTA

2 / 2



J.9.16
J.9.18

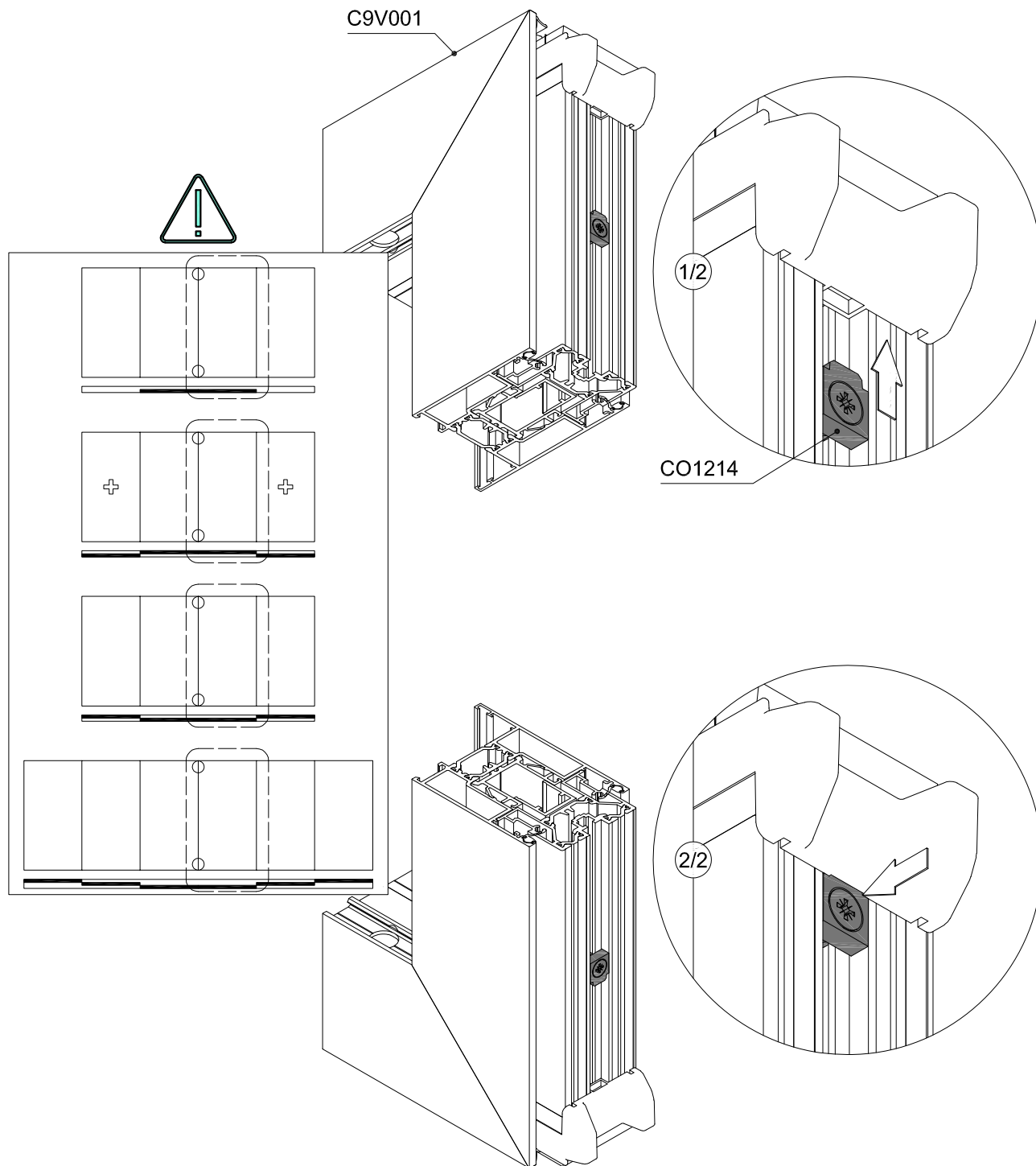
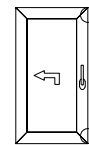

ANTA PASSIVA SCHEMA 4 ANTE - POSIZIONAMENTO INCONTRI DI CHIUSURA



J.9.17

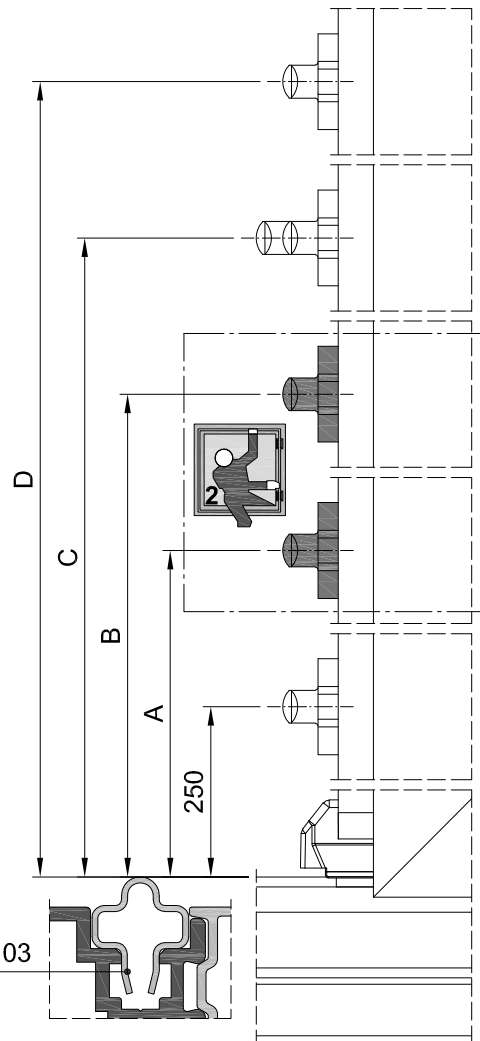
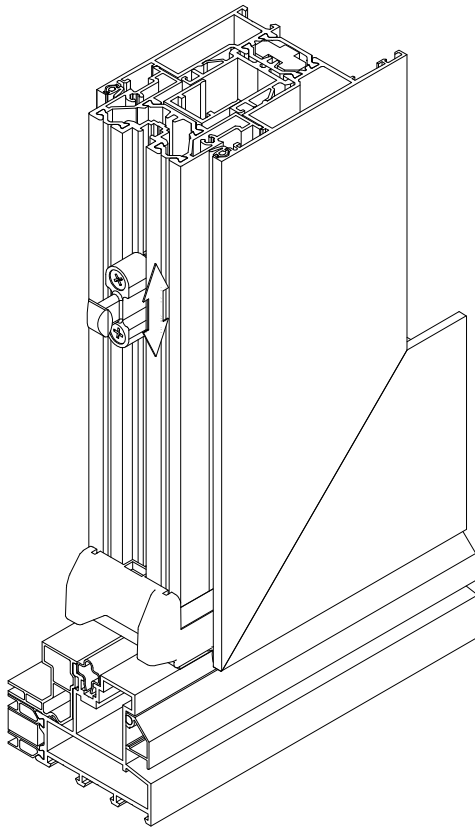
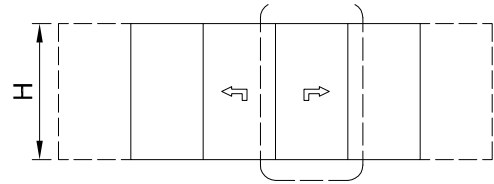

Hv	
H - 100	C9K012 C9K020 C9K021 C9K022 C9K023 C9K030 C9K120/C9K121 C9K130/C9K131
H - 82	C9K010
H - 88	C9K100/C9K120/C9K121

Icon	Hv	Accessories	Dimensions			
			A	B	C	D
	2010 - 2309	ZB0034	750	1200	1600	Hv - 271
	2310 - 2609	ZB0035			1900	
	2610 - 2909	ZB0036			2200	
	2910 - 3209	ZB0035 + ZB0046			1900	
	3210 - 3509	ZB0036 + ZB0046			2200	
	1312 - 2009	ZB0033		600	1000	

C160-ASS-2202



ANTA PASSIVA SCHEMA 4 ANTE - INSTALLAZIONE GUARNIZIONE DI FINITURA RU9704

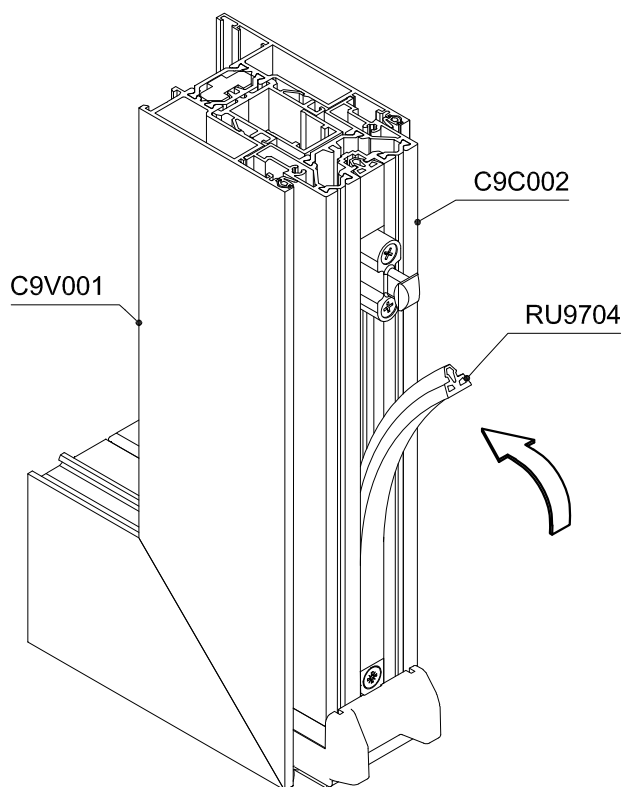
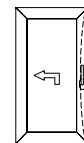

INSERIMENTO FINALE TAPPO DI TENUTA ANTE ALZANTE-SCORREVOLE

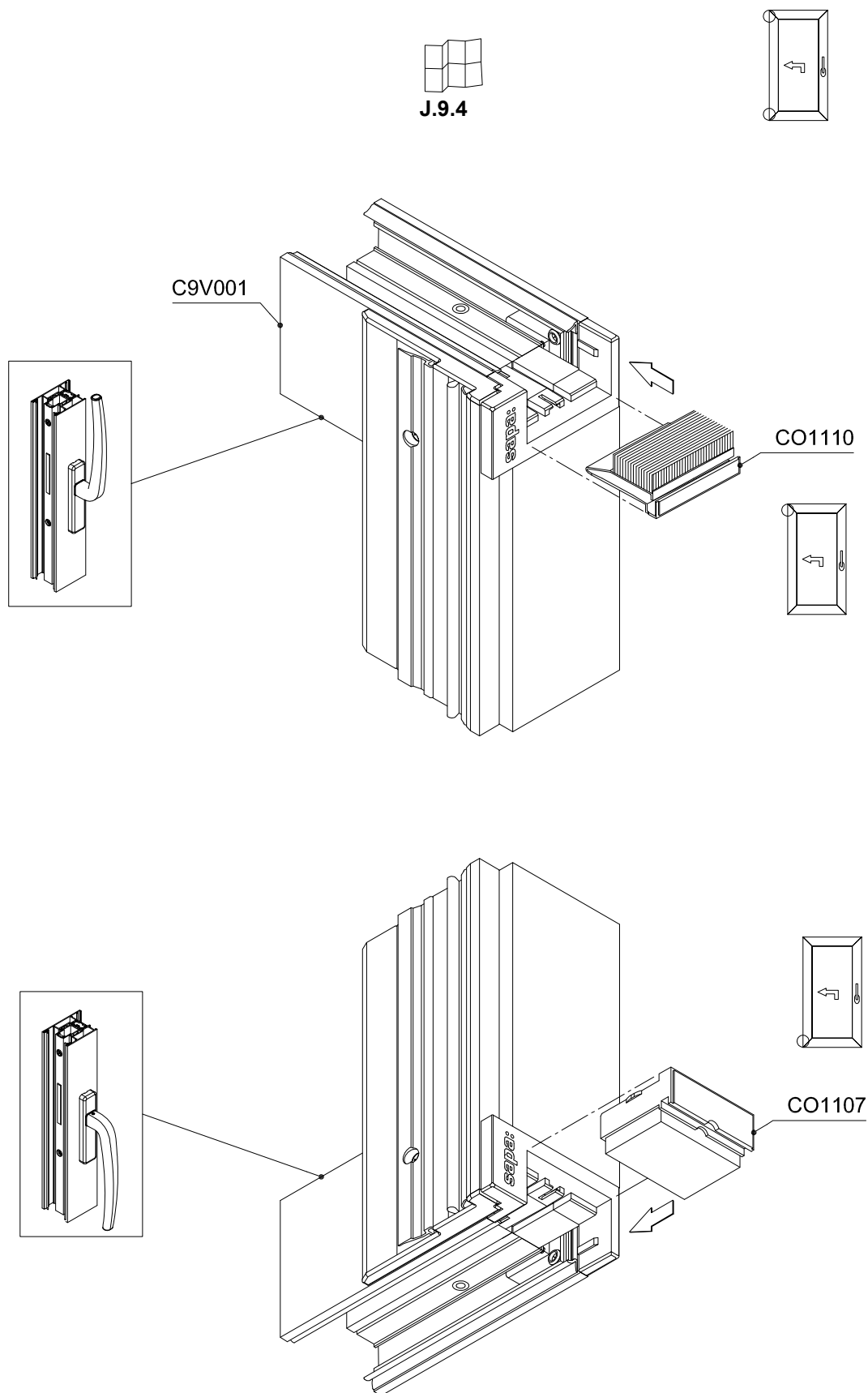



ASSEMBLAGGIO SUPPORTI VETRO VS5130

1 / 5

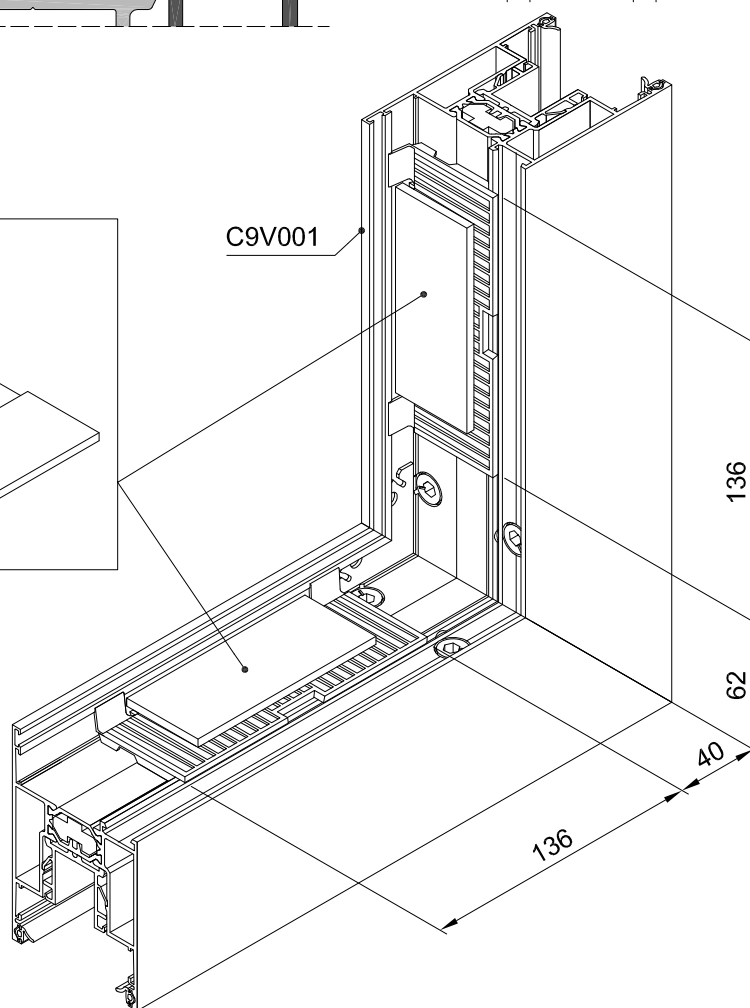
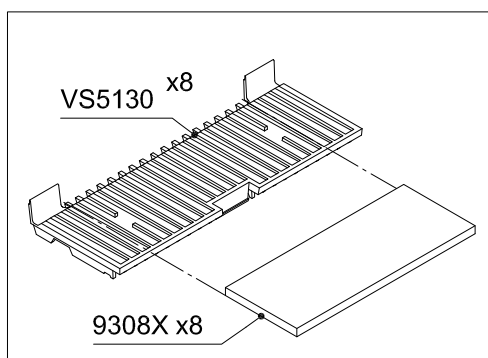
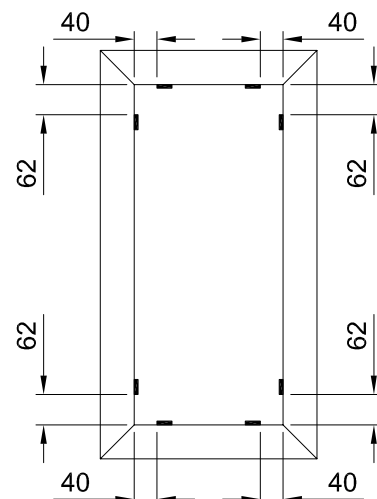
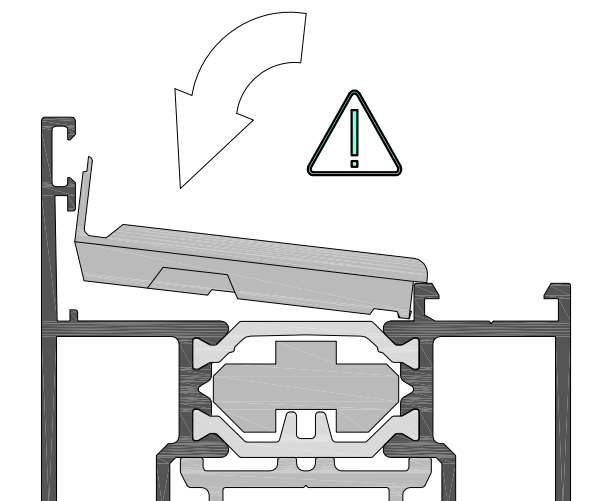
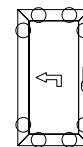

MONTAGGIO FERMAVETRO PER USO CON VS5130

2 / 5

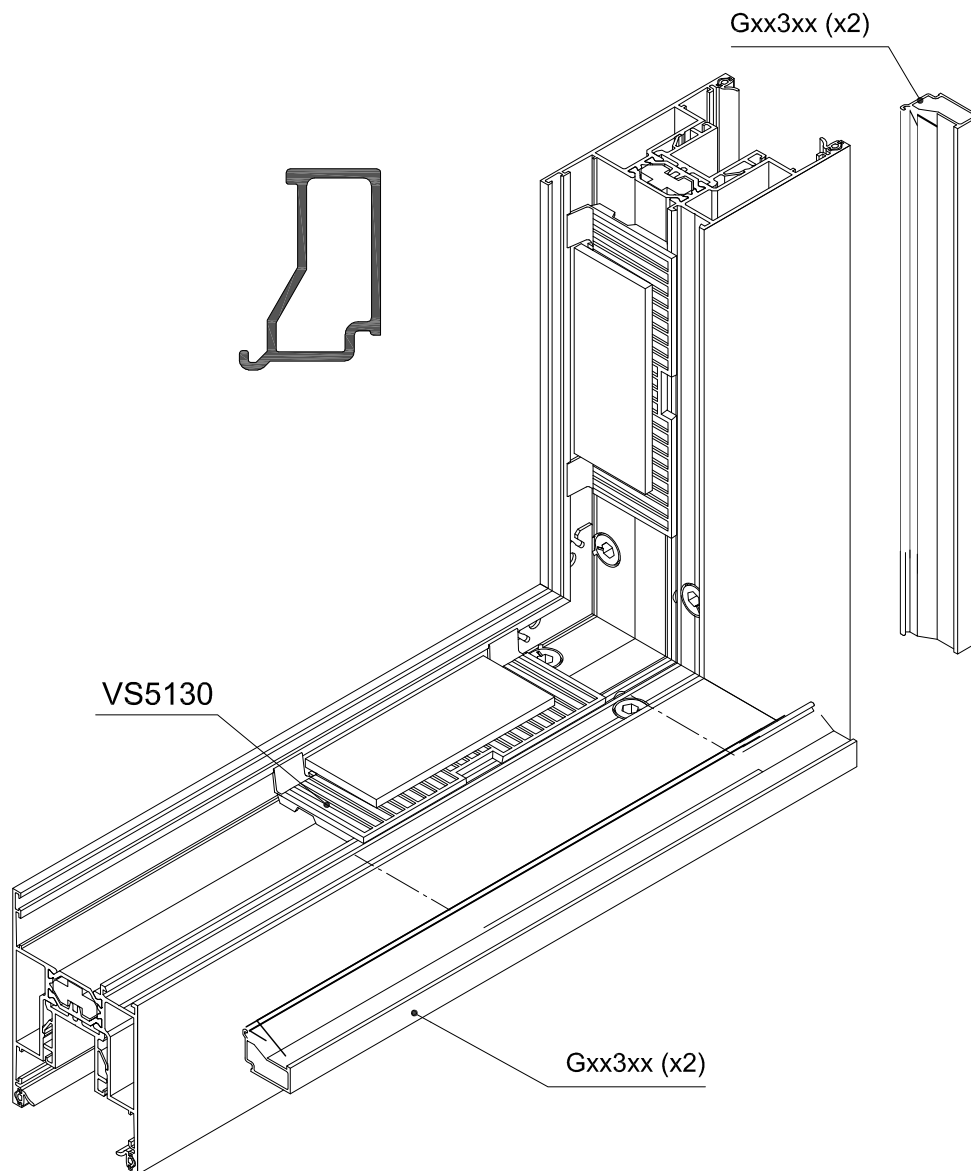
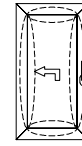



VETRATURA ANTA

VETRATURA SHI CON RU0002

3 / 5

C9V001+KU2027
C9V051+KU2027

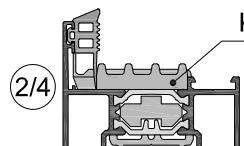
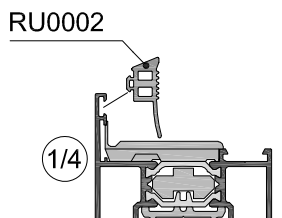
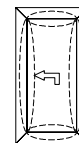

	KU5001
SHI	✓
SI	x
I	x

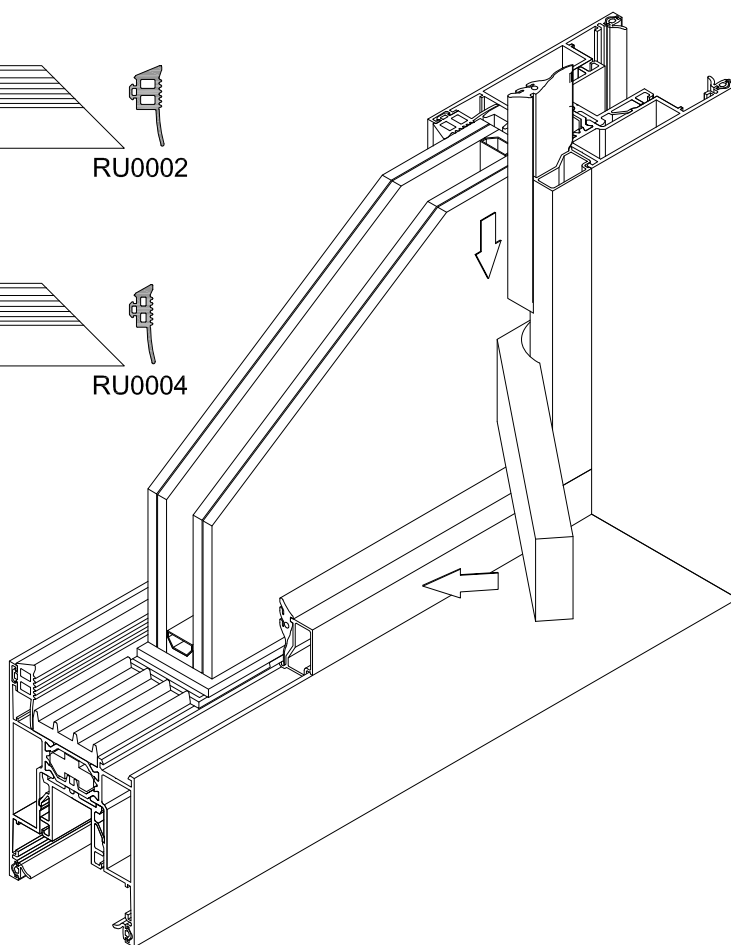
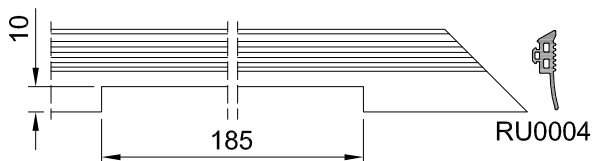
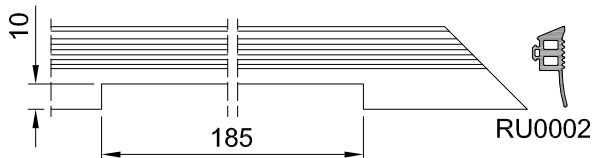
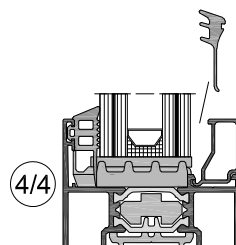
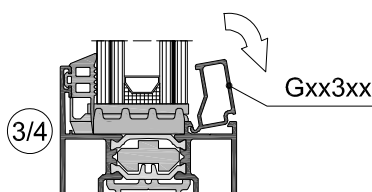



FERRAMENTA & DISEGNI ASSEMBLAGGIO

VETRATURA ANTA



VETRATURA TELAIO 1-BINARIO

1-BINARIO - ASSEMBLAGGIO SUPPORTO VETRO

1 / 7

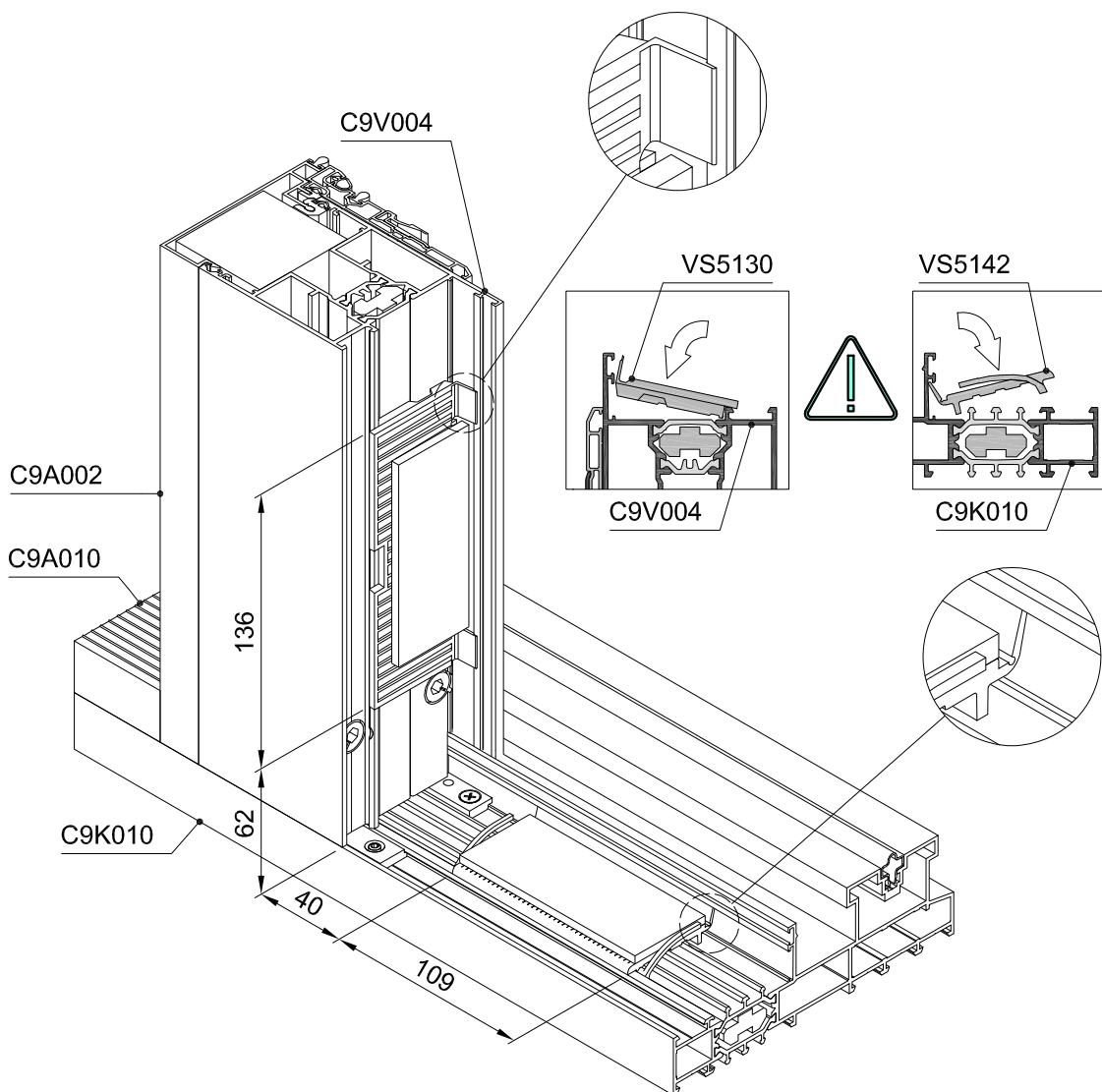
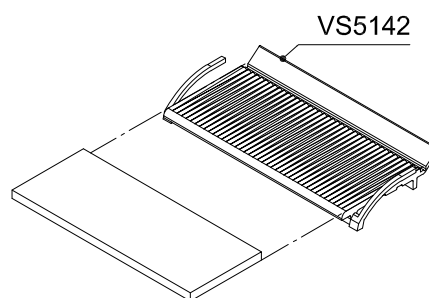
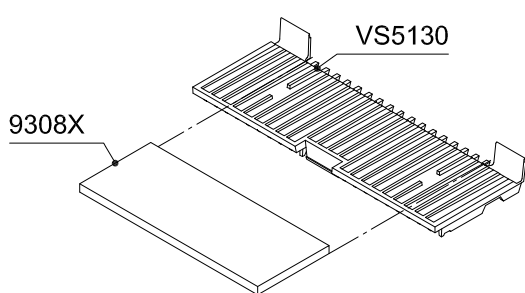
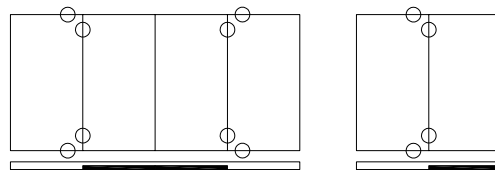

1-BINARIO - ASSEMBLAGGIO SUPPORTO VETRO

2 / 7

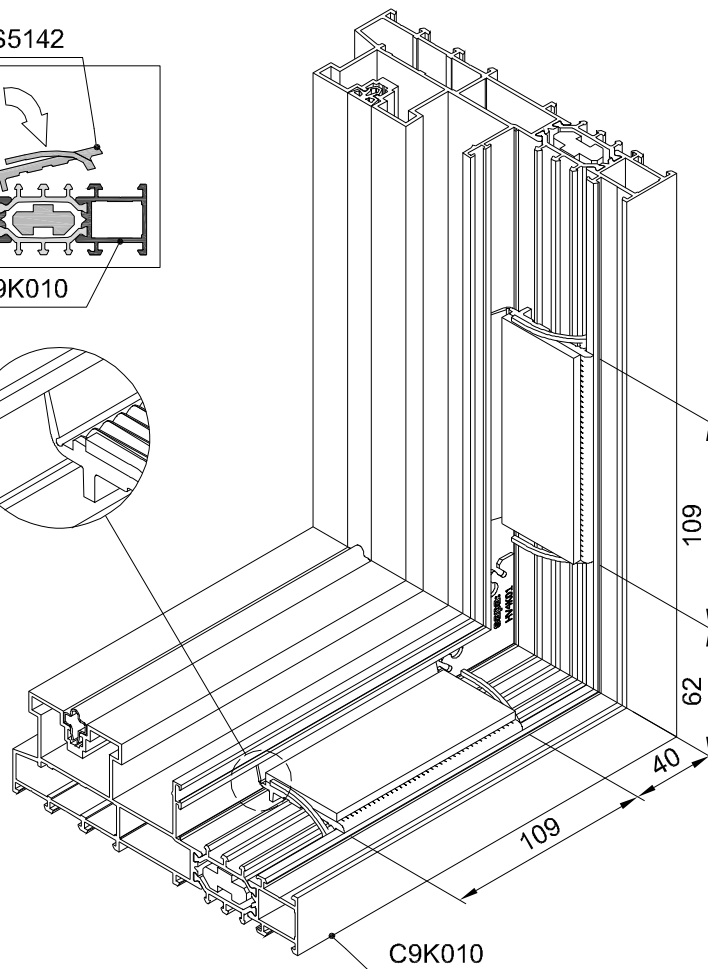
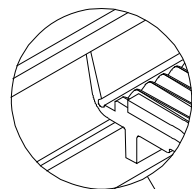
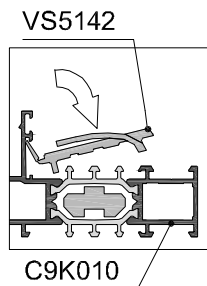
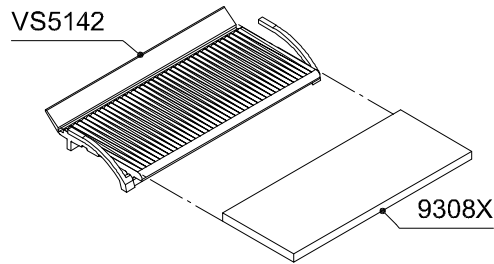
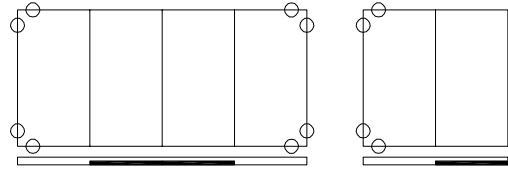



VETRATURA TELAIO 1-BINARIO

1-BINARIO - LAVORAZIONE FERMAVETRI

3 / 7

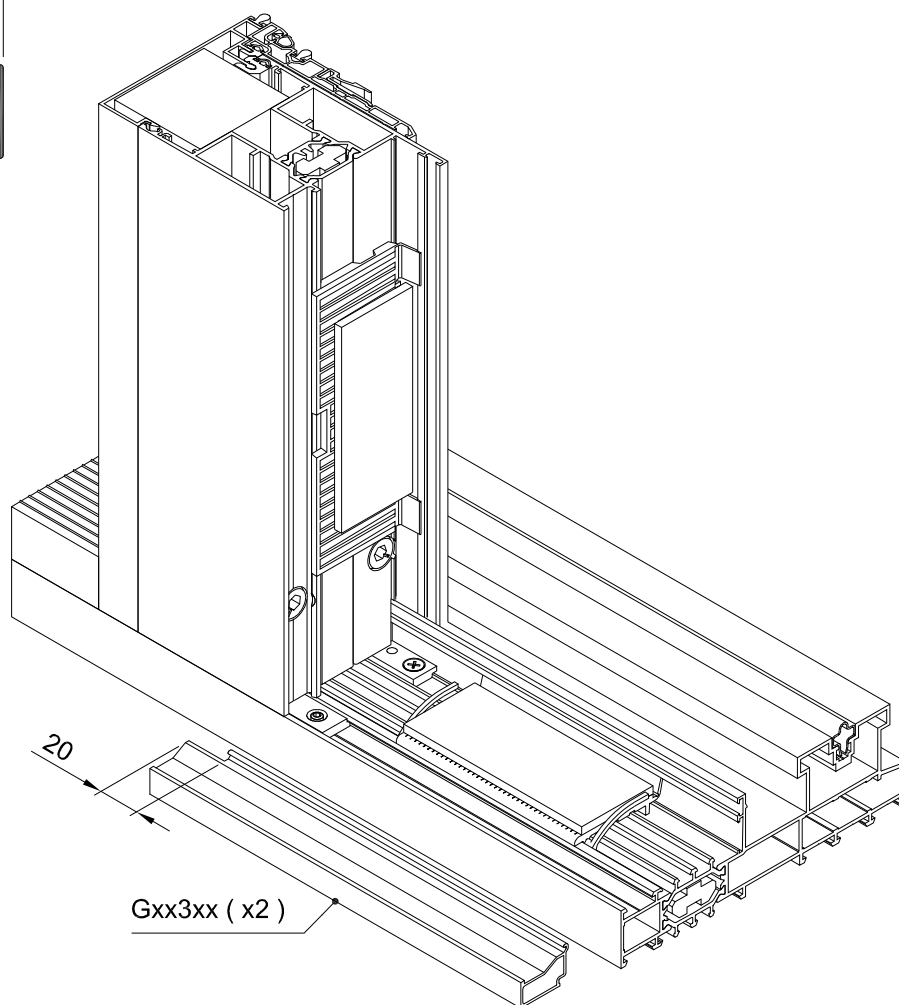
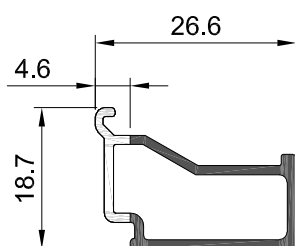
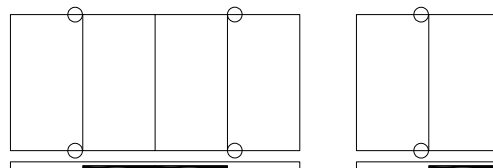

1-BINARIO - VETRATURA SHI CON RU0002

5 / 7

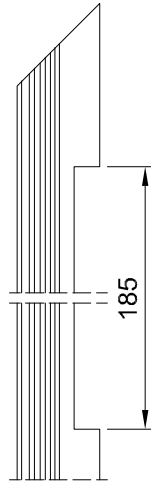
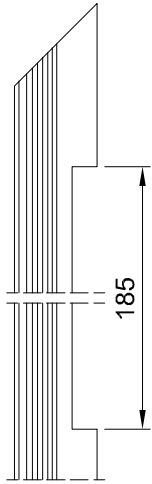
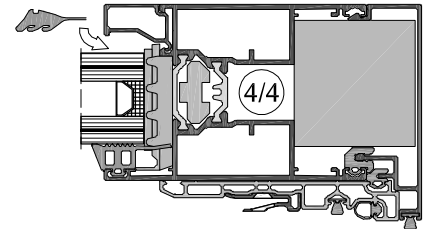
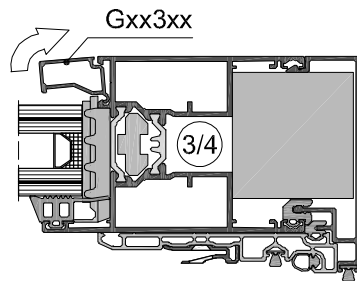
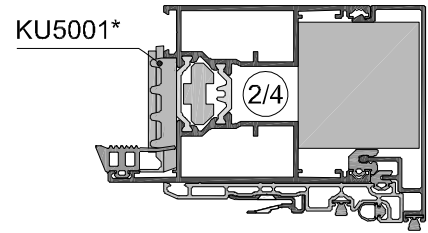
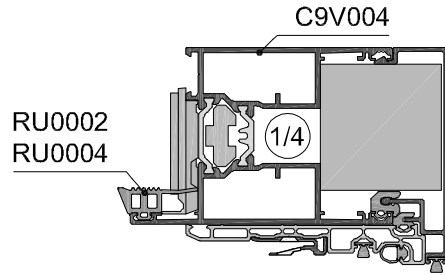
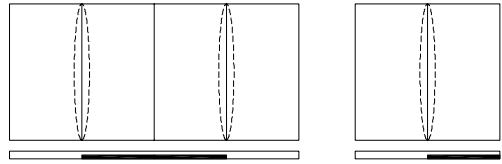

	KU5001	KU5004
SHI	✓	✓
HI	x	x
I	x	x

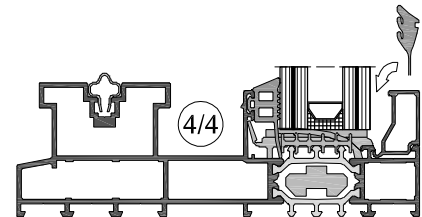
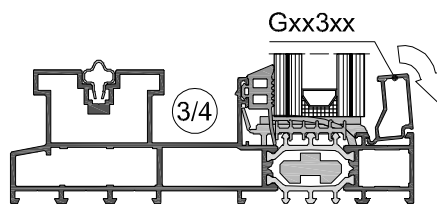
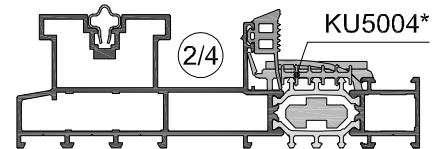
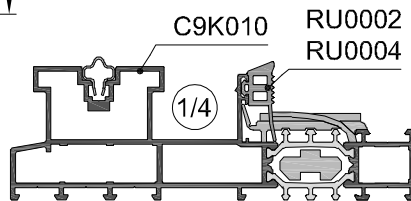
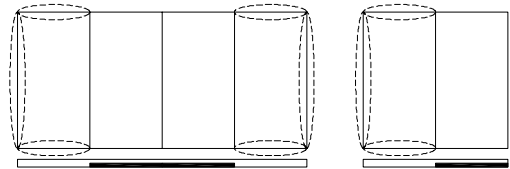



VETRATURA TELAIO 1-BINARIO

1-BINARIO - VETRATURA BASE CON 210-055

6 / 7

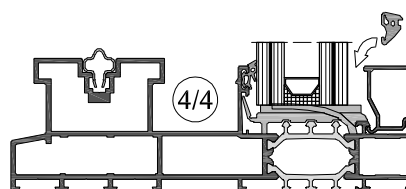
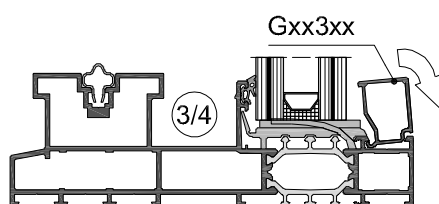
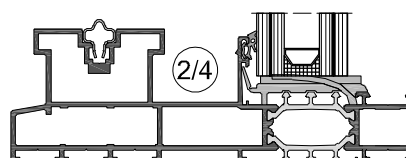
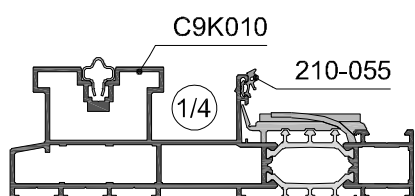
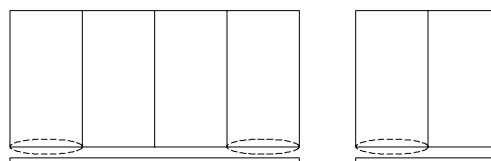

1-BINARIO - VETRATURA BASE CON 210-003

7 / 7

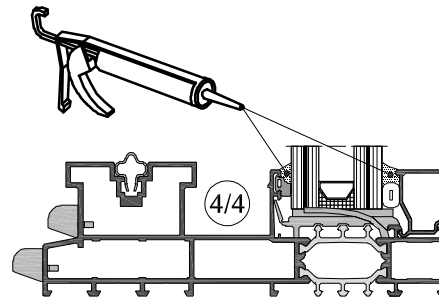
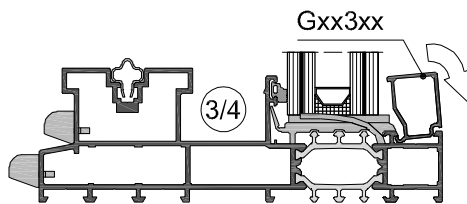
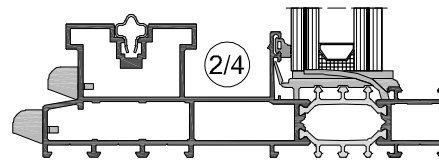
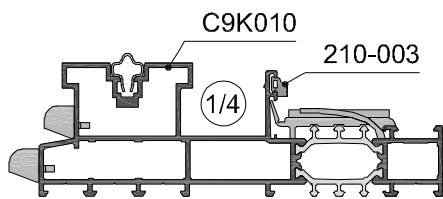
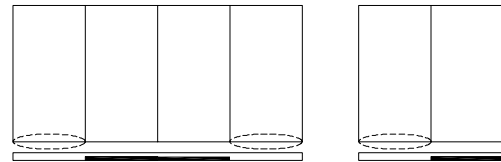



FERRAMENTA ALZANTE-SCORREVOLE

1 / 4

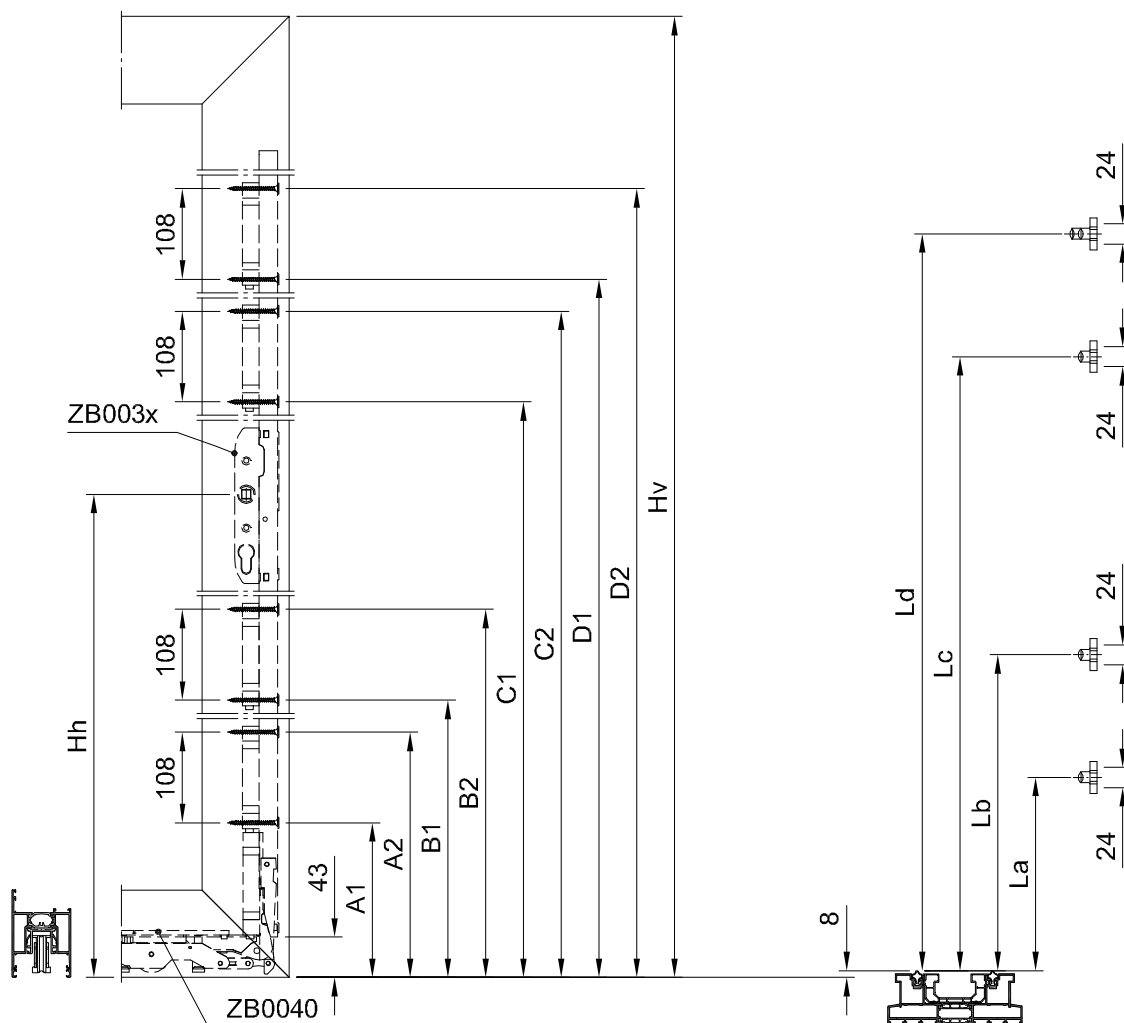

Hv			Hh	A		B		C		D		E	F		L				
min	max			A1	A2	B1	B2	C1	C2	D1	D2		F1	F2	La	Lb	Lc	Ld	Lf
1180	1877	ZB0033	403		-	-	-	554	662	954	1062					-	600	1000	
1878	2177	ZB0034	1003	204	312	704	812	1154	1262	1554	1662	-	-	-	250	750	1200	1600	
2178	2477	ZB0035								1854	1962							1900	
2478	2777	ZB0036								2154	2262							2200	
2778	3077	ZB0035 + ZB0046	Vedi Pagina 2 / 4																
3078	3377	ZB0035 + ZB0046																	

FERRAMENTA ALZANTE-SCORREVOLE

2 / 4

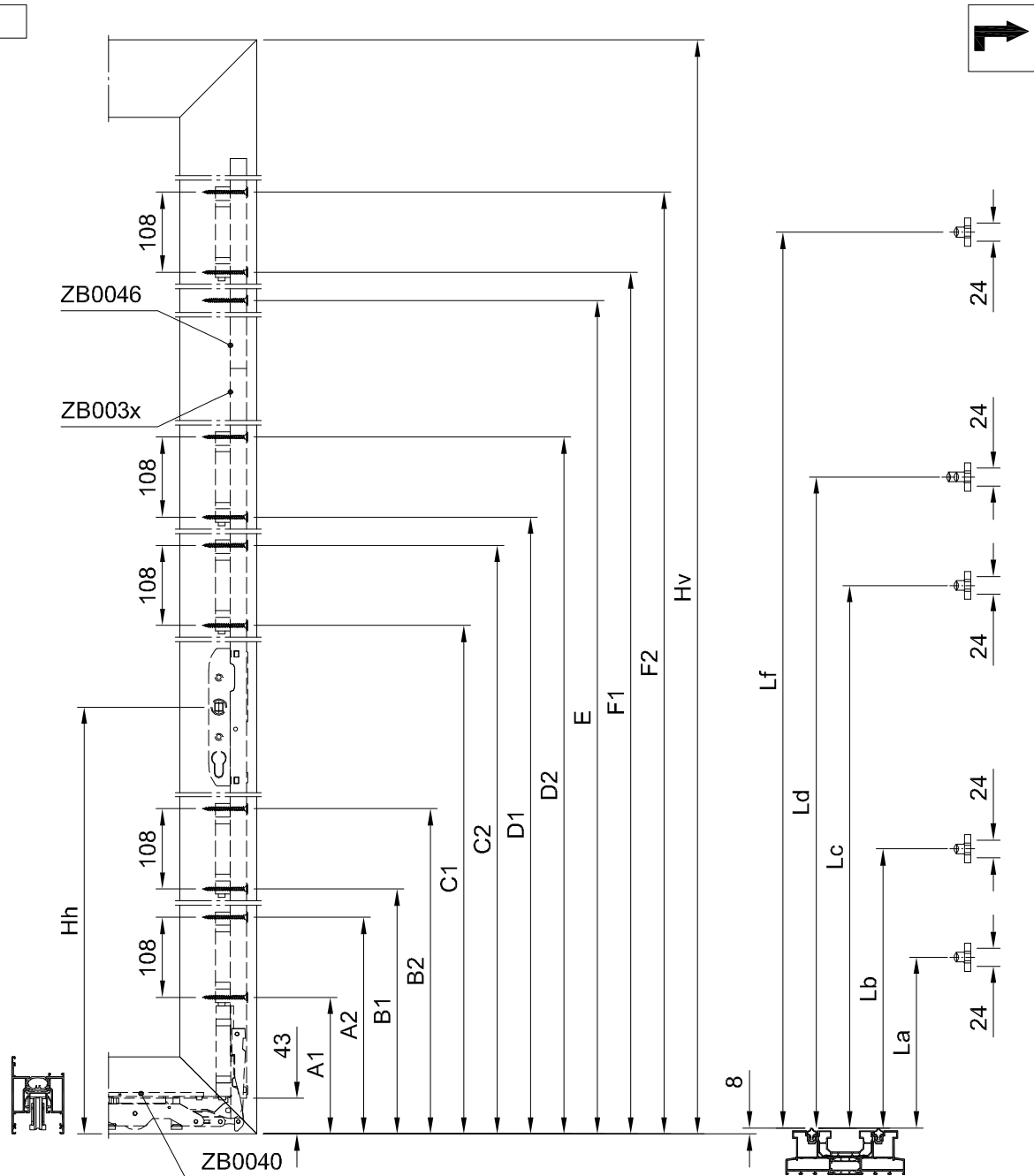

Hv		Hh	A		B		C		D		E	F		L					
min	max		A1	A2	B1	B2	C1	C2	D1	D2		F1	F2	La	Lb	Lc	Ld	Lf	
1180	1877	ZB0033	Vedi Pagina 1 / 4																
1878	2177	ZB0034																	
2178	2477	ZB0035																	
2478	2777	ZB0036																	
2778	3077	ZB0035 + ZB0046	1003	204	312	704	812	1154	1262	1854	1962	Hv - 549	Hv - 325	Hv - 217	250	750	1200	1900	Hv - 271
3078	3377	ZB0035 + ZB0046								2154	2262								

C160-ASS-3101



FERRAMENTA ALZANTE-SCORREVOLE

3 / 4

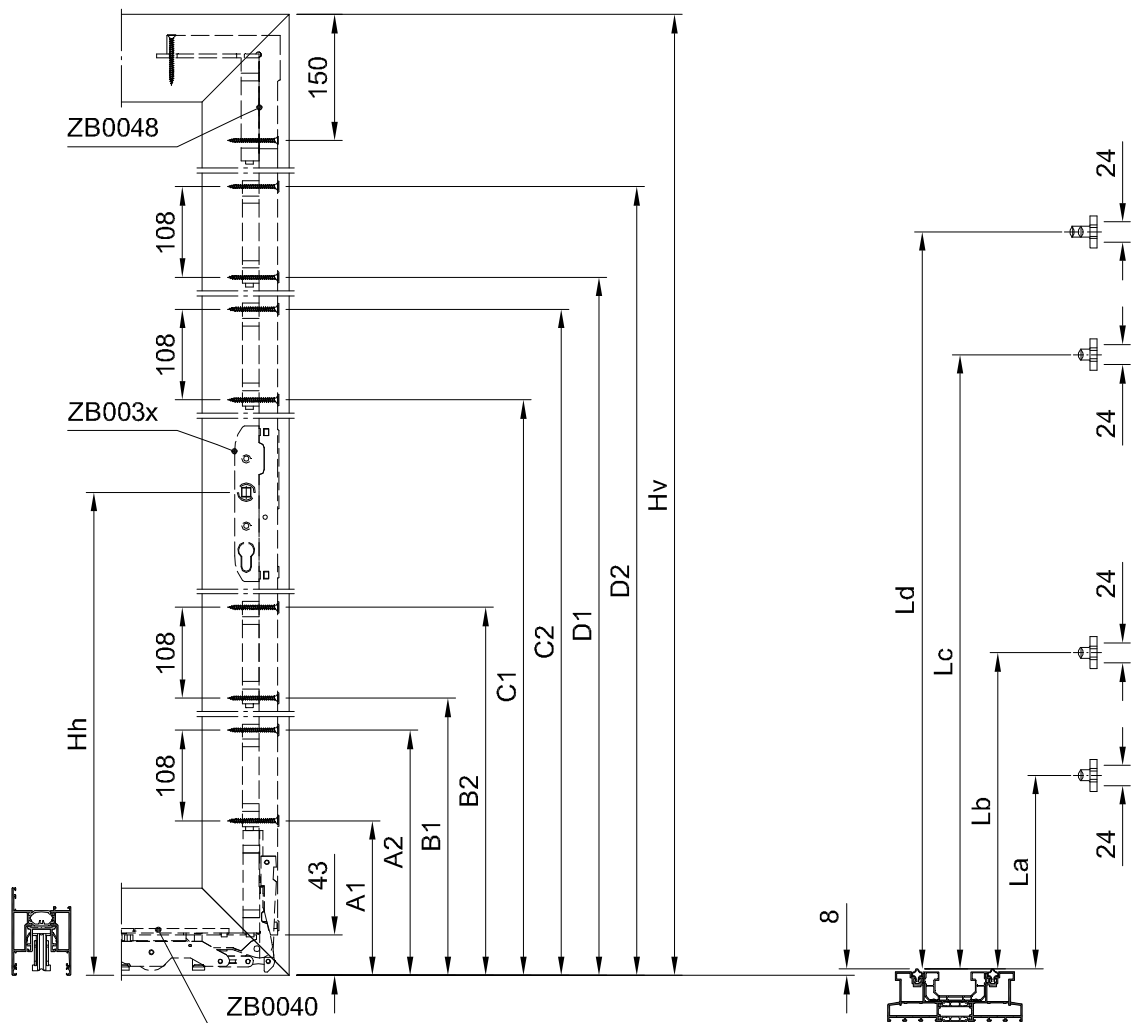
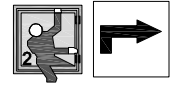

Hv			Hh	A		B		C		D		E	F		L				
min	max			A1	A2	B1	B2	C1	C2	D1	D2		F1	F2	La	Lb	Lc	Ld	Lf
1312	2009	ZB0033	403		-	-	-	554	662	954	1062					-	600	1000	
2010	2309	ZB0034	1003	204						1554	1662							1600	
2310	2609	ZB0035			312	704	812	1154	1262	1854	1962				250	750	1200	1900	
2610	2909	ZB0036								2154	2262							2200	
2910	3209	ZB0035 + ZB0046	Vedi Pagina 4 / 4																
3210	3509	ZB0035 + ZB0046																	

C160-ASS-3102

FERRAMENTA ALZANTE-SCORREVOLE

4 / 4

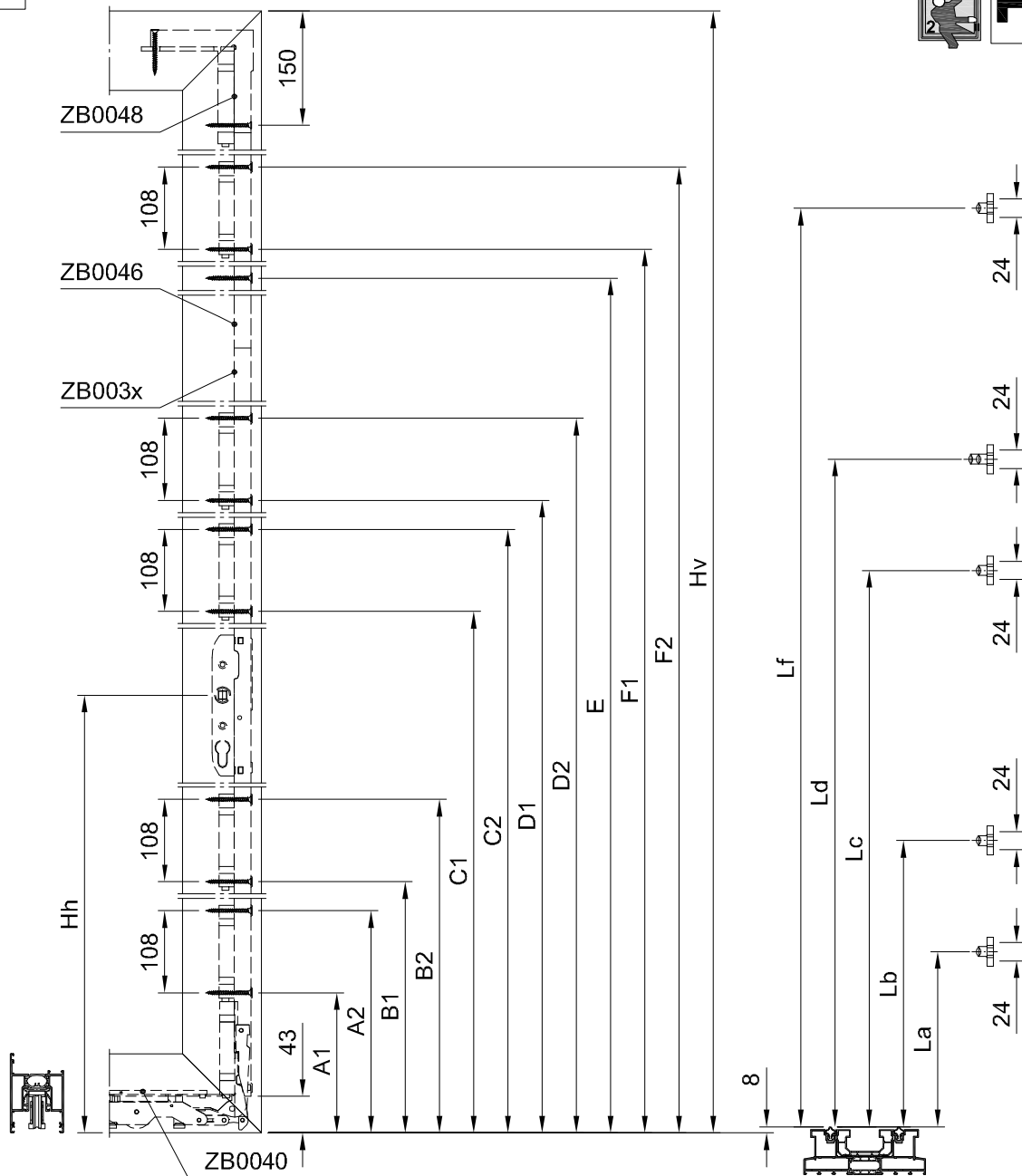
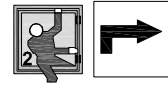

Hv		Hh	A		B		C		D		E	F		L					
min	max		A1	A2	B1	B2	C1	C2	D1	D2		F1	F2	La	Lb	Lc	Ld	Lf	
1312	2009	ZB0033	Vedi Pagina 3 / 4																
2010	2309	ZB0034																	
2310	2609	ZB0035																	
2610	2909	ZB0036																	
2910	3209	ZB0035 + ZB0046	1003	204	312	704	812	1154	1262	1854	1962	HV - 549	HV - 325	HV - 217	250	750	1200	1900	HV - 271
3210	3509	ZB0035 + ZB0046								2154	2262								

C160-ASS-3103



2-BINARI DRENAGGIO

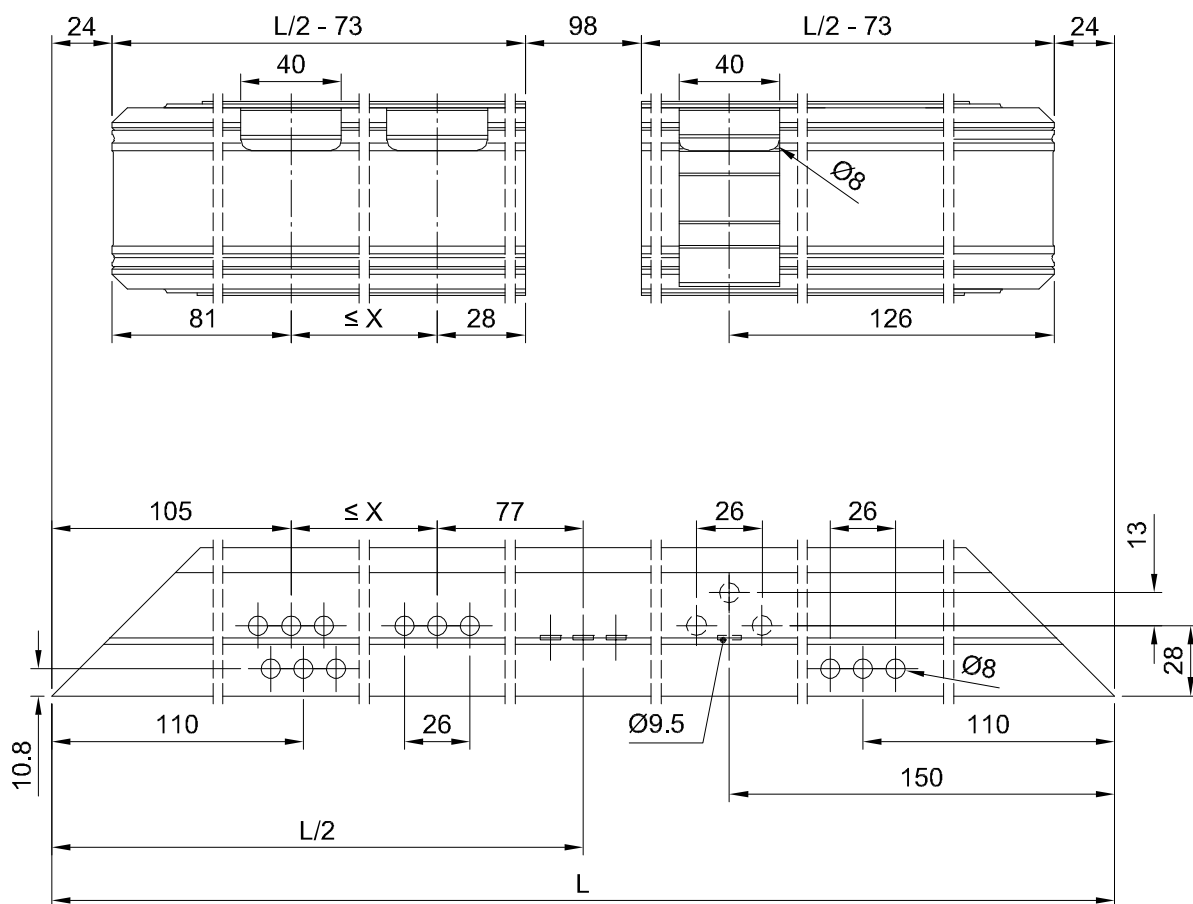

3-BINARI DRENAGGIO

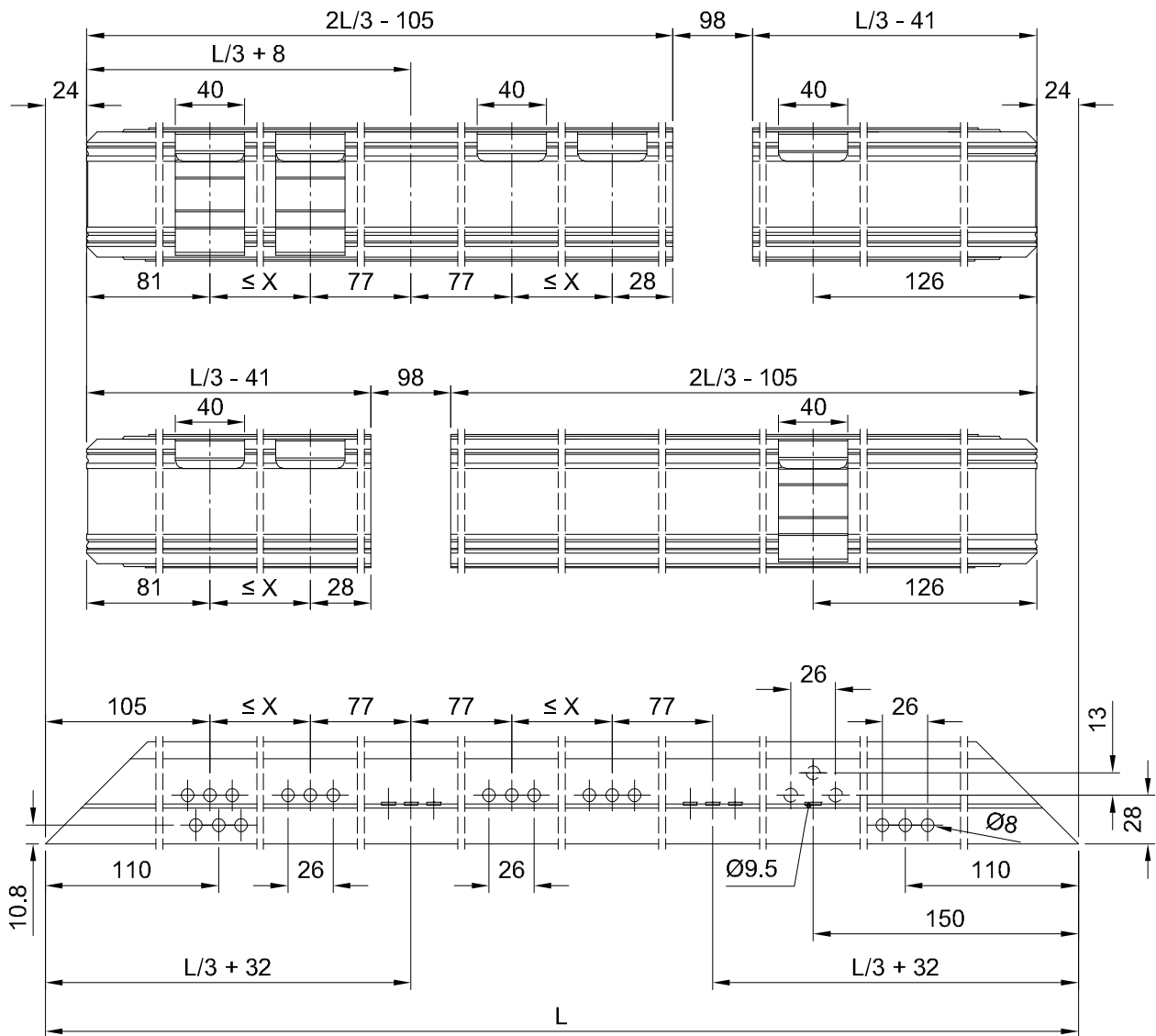



Allegati

LIMITI DI IMPIEGO - ALZANTE-SCORREVOLE

2 ANTE CON C9V001

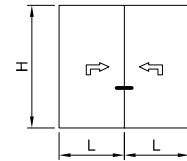
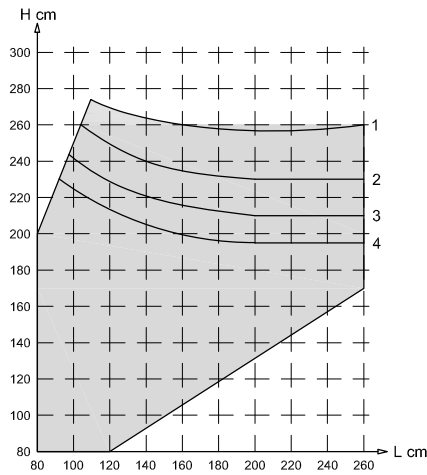
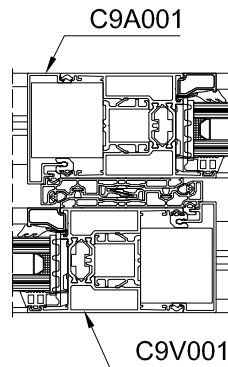
W (DAN/M ²)	80	120	160	200	$f \leq H/300$
	1 C2	2 C3	3 C4	4 C5	$F_{max} \leq 8 \text{ mm}$



 max. 300 kg/
(400 kg)

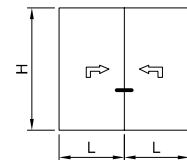
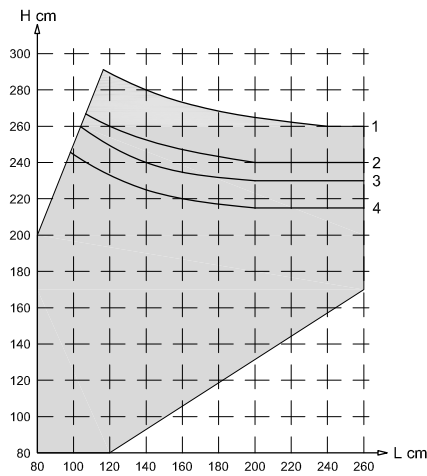
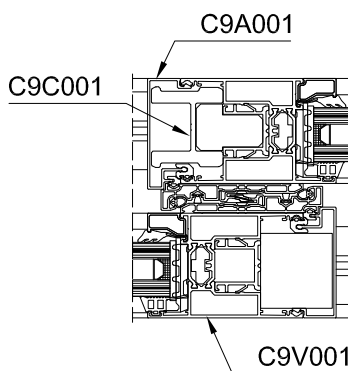

 max. 300 kg/
(400 kg)

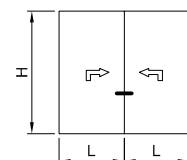
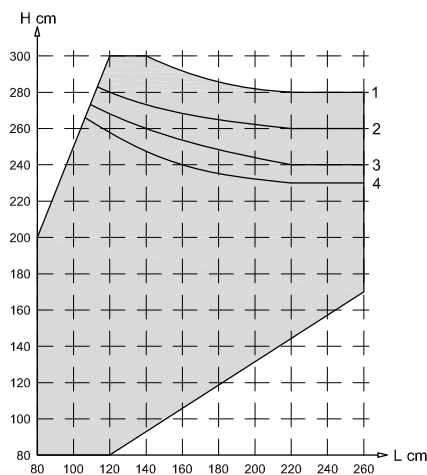
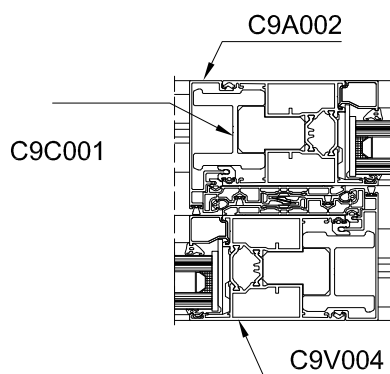

 max. 300 kg/
(400 kg)

2 ANTE CON C9V051

W (DAN/M ²)	80	120	160	200	$f \leq H/300$
	1	2	3	4	$F_{max} \leq 8 \text{ mm}$
	C2	C3	C4	C5	

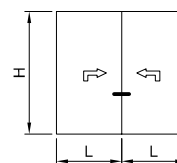
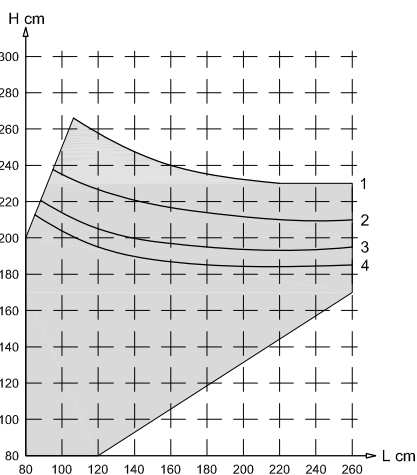
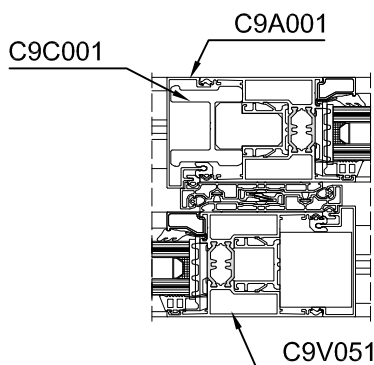

max. 300 kg/
(400 kg)

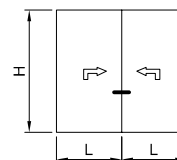
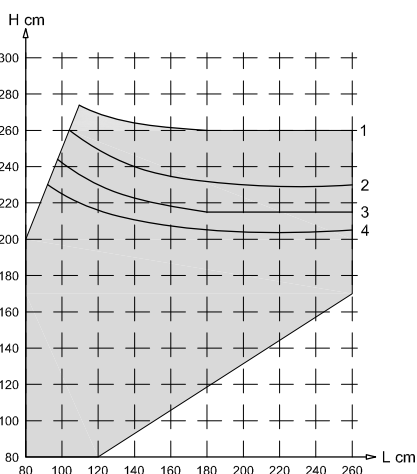
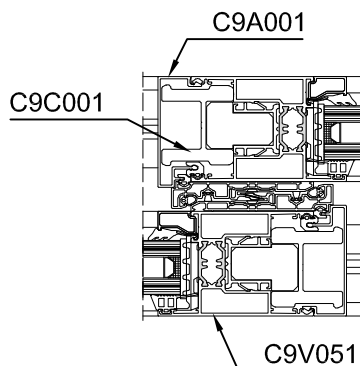

max. 300 kg/
(400 kg)

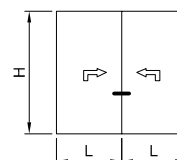
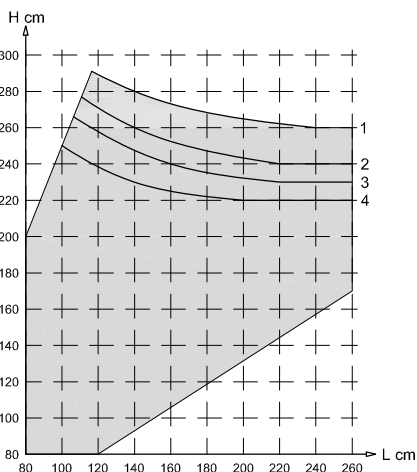
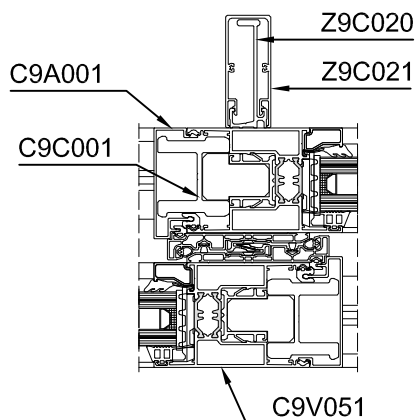

max. 300 kg/
(400 kg)

LIMITI DI IMPIEGO - ALZANTE-SCORREVOLE

4 ANTE

W (DAN/M ²)	80	120	160	200	$f \leq H/300$
	1	2	3	4	$F_{max} \leq 8 \text{ mm}$
	C2	C3	C4	C5	

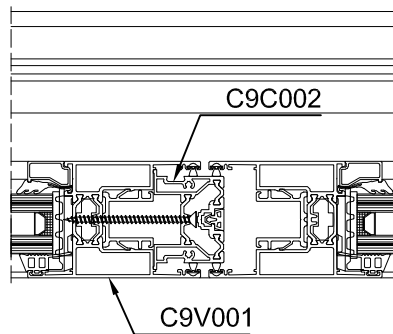
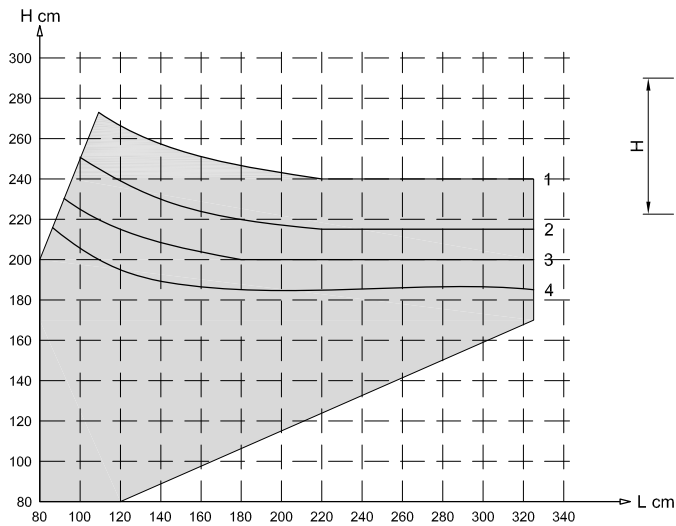



ALLEGATI

LIMITI DI IMPIEGO - ALZANTE-SCORREVOLE

VALORE UF DI FINESTRE E PORTE

La trasmittanza termica U_w dei serramenti nel loro complesso (telaio e vetratura) può essere calcolata con la procedura di calcolo semplificata descritta nella norma EN ISO 10077-1 che tiene conto della trasmittanza termica del telaio, del vetrocamera o del pannello e della trasmittanza termica lineare del distanziatore tra le due lastre vetrate del vetrocamera:

$$U_w = \frac{U_f A_f + U_g A_g + U_p A_p + \Psi_g L_g + \Psi_p L_p}{A_f + A_g + A_p} \left[\frac{W}{m^2 K} \right]$$

dove:

- A_f area del telaio in m^2 definita come l'area della proiezione della superficie del telaio su un piano parallelo al vetro. Corrisponde all'area più grande tra l'area della superficie frontale interna $A_{f,i}$ e l'area della superficie frontale esterna $A_{f,e}$;
- U_f trasmittanza termica del telaio metallico in W/m^2K .
- A_g area della vetratura in m^2 ;
- U_g trasmittanza termica dell'elemento vetrato in W/m^2K ;
- U_p trasmittanza termica del pannello opaco in W/m^2K ;
- A_p area del pannello in m^2 ;
- L_g perimetro della vetratura in metri; se il perimetro visto dall'interno differisce da quello visto dall'esterno deve essere assunto il valore maggiore delle lunghezze perimetrali;
- L_p perimetro del pannello opaco in metri;
- ψ_l trasmittanza lineare in W/mK (da considerarsi solo nel caso del vetro camera) dovuta alla presenza del distanziatore posto tra i due vetri; si ricava in funzione del tipo di vetro e del materiale del telaio; tale valore si considera nullo per vetri singoli. Questo parametro è introdotto per tenere conto della *dispersione termica perimetrale* che si verifica in prossimità del bordo del vetrocamera per la presenza del distanziatore.
- ψ_p trasmittanza termica lineare in W/mK . Può essere calcolata secondo la metodologia descritta dalla norma UNI EN ISO 10077-2. Questo valore può essere posto uguale a zero quando:
 - le superfici interne ed esterne del pannello sono di materiale con conduttività termica inferiore a 0,5 W/mK ;
 - la conduttività termica di qualsiasi materiale di collegamento al bordo del pannello è inferiore a 0,5 W/mK .

Con calcolo semplificato può essere valutata anche la trasmittanza termica di serramenti doppi U_{wD} (costituiti cioè da telai fissi separati):

$$U_{wD} = \frac{1}{\frac{1}{U_{w1}} - R_{SI} + R_S + R_{SE} + \frac{1}{U_{w2}}} \left[\frac{W}{m^2 K} \right]$$

dove:

- U_{w1} trasmittanza termica del serramento esterno calcolata secondo la prima formula, in W/m^2K .
- U_{w2} trasmittanza termica del serramento interno calcolata secondo la prima formula in W/m^2K
- R_{SI} resistenza termica superficiale interna del serramento esterno quando previsto da solo.
- R_{SE} resistenza termica superficiale esterna del serramento interno quando previsto da solo.
- R_S resistenza termica dello spazio compreso tra le vetrazioni dei due serramenti in m^2K/W

Con calcolo semplificato può essere valutata anche la trasmittanza termica di **serramenti accoppiati** U_{wA} (caratterizzati dalla presenza di un telaio fisso unico):

$$U_{wD} = \frac{1}{\frac{1}{U_{G1}} - R_{SI} + R_S + R_{SE} + \frac{1}{U_{G2}}} \left[\frac{W}{m^2 K} \right]$$

dove:

- U_{G1} trasmittanza termica della vetratura esterna
- U_{G2} trasmittanza termica della vetratura interna
- R_{Si} resistenza termica superficiale interna della vetratura esterna quando applicata da sola.
- R_{SE} resistenza termica superficiale esterna della finestra interna
- R_s resistenza termica dello spazio compreso tra la vetratura esterna e quella interna del serramento accoppiato in m^2K/W .

La resistenza termica di una lastra di vetro è fortemente influenzata dalle resistenze superficiali sia interne sia esterne, di conseguenza la presenza di elementi di schermatura contribuisce a modificare lo scambio termico (e conseguentemente tali valori di resistenza liminare) aumentandone la sua resistenza termica.

Pertanto è possibile considerare per i serramenti una *resistenza termica aggiuntiva* che tiene conto della presenza di schermi esterni (tapparelle, persiane, ecc.) e della permeabilità all'aria del serramento. Si esprime cioè la prestazione termica dei serramenti a schermi chiusi tramite la cosiddetta trasmittanza termica notturna U_{WS} :

$$U_{WS} = \frac{1}{\frac{1}{U_W} + \Delta R} \quad \frac{W}{m^2 K}$$

dove:

- U_W trasmittanza termica del serramento in W/m^2K ;
- ΔR resistenza termica aggiuntiva in m^2K/W dovuta alla presenza degli schermi chiusi il cui valore può essere definito in funzione della permeabilità e della resistenza termica R_{sh} degli schermi.

Per la valutazione del contributo delle chiusure oscuranti si può far riferimento alla procedura descritta nella norma EN ISO 10077-1.

TABELLA DI CONTROLLO DEL SERRAMENTO FINITO

Posizione	Caratteristica da esaminare	Requisito	Metodo di prova	Tolleranze
1	Dimensioni telaio	Documenti di commessa	Metro	$\pm 0.5 \text{ mm}$
2	Dimensioni ante	Istruzioni di lavorazione	Metro	$\pm 0.5 \text{ mm}$
3	Angoli	Istruzioni di lavorazione	Goniometro	$\pm 0.5^\circ$
4	Taglio guarnizioni	Istruzioni di lavorazione	Documenti di produzione	$L \times 1.01 \pm 2 \text{ mm}$
5	Montaggio guarnizioni	Istruzioni di lavorazione	Visivo	
6	Sigillatura giunzioni	Istruzioni di lavorazione	Visivo	
7	Numero di drenaggi	Istruzioni di lavorazione	Visivo	
8	Fori di ventilazione	Istruzioni di lavorazione	Visivo	
9	Posizionamento vetrocamera	Istruzioni di lavorazione	Documenti di produzione	
10	Componenti della ferramenta	Completezza	Visivo	
11	Posizionamento della ferramenta	Istruzione di montaggio	Visivo	
12	Regolazione della ferramenta	Istruzione di montaggio	Calibro a corsoio	
13	Funzionamento ferramenta	Istruzione di montaggio	Prova di funzionamento	

CONDIZIONI GENERALI DI VENDITA

1. Premessa

- Le presenti condizioni generali di vendita si applicano integralmente ad ogni ordine e a tutte le nostre vendite, salvo stipulazione contraria che deve risultare espressamente e per iscritto da parte della nostra Società.

- L'invio o la consegna di qualsiasi ordine di acquisto da parte dell'Acquirente alla nostra Società implica l'accettazione integrale e senza riserve da parte sua delle condizioni generali di vendita della nostra Società.

- Le presenti condizioni generali sono riportate in ogni modulo di conferma d'ordine, nei manuali, anche informativi, nei cataloghi e nel sito della nostra Società e si considerano conosciute da tutti i Compratori.

2. Offerte

- Le offerte formulate dalla nostra Società sono senza impegno e non valgono quale proposta.

- Le offerte sono subordinate alle condizioni generali di vendita.

- Le condizioni generali di vendita sono riportate nella nostra offerta e s'intendono accettate mediante invio o consegna dell'Ordine/Commessa.

3. Ordini/Commessa

- Ogni ordine/commessa formulato dall'Acquirente è soggetto ad accettazione scritta (c.d. Conferma) da parte della nostra Società ed implica l'accettazione delle condizioni generali della nostra Società.

- Gli ordini devono essere completi e definiti in ogni loro parte mediante Distinta inviata a mezzo fax o e-mail.

- La trasmissione dell'ordine impegna l'Acquirente ai dati contenuti nella propria scheda commerciale consegnatagli da nostro delegato e comunque, se non diversamente specificato per iscritto, ai prezzi, alle condizioni di listino ed alle condizioni generali di vendita della nostra Società in vigore alla data di conferma d'ordine.

- Eventuali richieste di variazioni, modifiche o cancellazione dell'ordine da parte dell'Acquirente sono soggette ad approvazione da parte della nostra Società e dovranno pervenire unicamente e inderogabilmente entro 12 ore lavorative dall'invio dell'ordine solo a mezzo e-mail o fax.

- Le 12 ore verranno calcolate considerando data e ora indicata sulla e-mail/fax dell'invio ordine e sulla e-mail/fax di richiesta cancellazione/variazione.

- In caso di variazioni dell'ordine la nostra Società si riserva la facoltà di ritardare i tempi di consegna e di modificare il prezzo.

4. Conferme d'Ordine

- La Conferma d'Ordine della nostra Società giungerà all'Acquirente a mezzo e-mail, fax, posta, o a mano.

- La Conferma d'Ordine inviata dalla nostra Società definisce e riporta tutte le condizioni e i contenuti definitivi e vincolanti del Contratto, sostituendosi integralmente all'ordine/commessa.

- La Conferma d'Ordine e le presenti condizioni generali di contratto prevarranno in ogni caso su eventuali condizioni generali o particolari di acquisto predisposte dall'Acquirente.

- Qualsiasi condizione scritta o verbale inviata da parte di nostri collaboratori, funzionari di vendita dipendenti della nostra Società o agenti di vendita è priva di valore se non riprodotta nel testo della nostra conferma d'ordine o se non confermata per iscritto dalla nostra Società.

5. Oggetto del contratto

- Il contratto ha ad oggetto la fornitura dei materiali, per i quantitativi specificati nella nostra Conferma d'Ordine o in ogni eventuale successiva modifica trasmessa via fax, mail o a mani dalla nostra Società.

- Non rientrano nell'oggetto del presente contratto con la nostra Società i campioni di materiale e i prototipi da sottoporre a prove e/o a test, tutte le informazioni rese in qualsiasi forma o sede per le lavorazioni dei nostri prodotti, quali ad esempio proposte di calcoli, di progetti, di disegni, informazioni relative all'assemblaggio, all'installazione, alla lavorazione, alle verifiche statiche, all'offerta per gare d'appalto; pertanto non ci assumiamo alcuna responsabilità per le fasi di lavorazione successive alla fornitura dei nostri prodotti, anche con riguardo alla loro interazione con altri prodotti.

- In ogni caso, le dimensioni, gli schemi di montaggio e di lavorazione, i prezzi, le prestazioni e gli altri dati figuranti nei cataloghi, nei manuali di lavorazione, nei prospetti, negli annunci pubblicitari, nelle illustrazioni, nei listini prezzi, od in altri documenti illustrativi della nostra Società, così come le caratteristiche dei modelli e campioni inviati dalla nostra Società all'Acquirente, hanno carattere di mere indicazioni, non saranno vincolanti e non contengono alcuna promessa di qualità in relazione ai prodotti.

- Tali dati non hanno valore impegnativo se non sono espressamente richiamati nella Conferma d'ordine.

- La nostra Società si riserva di apportare in qualunque momento ai propri prodotti quelle modifiche tecniche non sostanziali, dettate da esigenze di produzione, che riterrà convenienti, senza obbligo di comunicazione.

6. Prezzi

- I prezzi delle nostre merci si intendono sempre Porto Franco (DDP per gli Incoterms), salvo diversa pattuizione tra le parti. I pagamenti e ogni altra somma dovuta a qualsiasi titolo alla nostra Società si intendono netti al domicilio della nostra Società.

- Eventuali pagamenti fatti ad agenti, rappresentanti, funzionari di vendita, dipendenti o collaboratori della nostra Società non saranno considerati validi fino a quando le relative somme non giungeranno alla nostra Società.

- I prezzi applicati sono quelli indicati nel listino prezzi della nostra Società valido al momento della consegna dei nostri prodotti allo spedizioniere, oltre alle rispettive imposte sul valore aggiunto, salvo diversa indicazione da provarsi per iscritto contenuta nella nostra Conferma d'ordine o in altro documento da noi proveniente.

7. Condizioni di pagamento

- Il pagamento dovrà essere effettuato, salvo diverso accordo scritto, a fine mese dalla data della fattura o entro il diverso termine indicato nella fattura, a mezzo di ricevuta bancaria, bonifico bancario presso l'istituto bancario indicato dalla nostra Società o tramite rimessa diretta. Vale quale consegna della merce il ritiro della merce da parte dello spedizioniere o il ritiro autonomo della merce da parte dell'Acquirente se concordato tra le parti.

- La nostra Società si riserva di chiedere degli acconti sul prezzo da versare al momento della conclusione del contratto o successivamente.

8. Ritardati pagamenti

- In caso di ritardato, mancato o parziale pagamento da parte dell'Acquirente, la nostra Società si riserva il diritto di sospendere immediatamente la fornitura, e/o di risolvere tutti i contratti in essere con l'Acquirente, anche se non relativi al

pagamento in questione, fatto salvo il diritto al risarcimento del danno.

- In caso di ritardato, mancato o parziale pagamento, su tutte le somme dovute matureranno interessi di mora calcolati ai sensi dell'art. 5, comma 2, del decreto legislativo 9 ottobre 2002, n. 231 ("Attuazione della direttiva 2000/35/CE relativa alla lotta contro i ritardi di pagamento nelle transazioni commerciali" pubblicato nella Gazzetta Ufficiale n. 249 del 23 ottobre 2002) senza necessità di messa in mora e tutti i crediti diventeranno immediatamente esigibili con decadenza dal beneficio del termine.

- Nessuna contestazione per eventuali inadempimenti, né eccezione alcuna, né azioni legali di qualsiasi natura potrà essere sollevata od esercitata dall'Acquirente se non previo integrale pagamento del prezzo.

- Non è ammessa alcuna compensazione fra il prezzo dovuto alla nostra Società ed eventuali crediti vantati dall'Acquirente.

- L'Acquirente è obbligato al pagamento integrale del prezzo anche in caso di contestazioni.

9. Consegna

- Salvo patto contrario, la fornitura della merce si intende Porto Franco.

- E' facoltà della nostra Società effettuare forniture parziali e/o consegne ripartite della merce.

- I termini di consegna indicati nella Conferma d'Ordine non sono termini essenziali, salvo diverso accordo. La forza maggiore o altre circostanze eccezionali o imprevedibili che si verificassero nei confronti della nostra Società o dei nostri fornitori (quali a mero titolo di esempio scioperi, blocchi stradali, etc. etc.) sospendono i termini per la consegna, senza alcuna responsabilità per la nostra Società.

- Qualora vi sia un ritardo nella consegna della merce superiore ai 30 (trenta) giorni, che non dipenda da forza maggiore o da eventi imprevedibili, è fatto obbligo all'Acquirente contestare per iscritto tale ritardo alla nostra Società, la quale avrà un termine di ulteriori 30 (trenta) giorni per effettuare la consegna. Nessun diritto al risarcimento del danno spetterà all'Acquirente.

- In caso di consegne ripartite, valgono le disposizioni che precedono.

- La nostra Società non risponde per danni da anticipata o ritardata consegna, totale o parziale.

10. Rischio di perimento della merce

- Il rischio del perimento o della rovina della merce passa in capo all'Acquirente al più tardi quanto la stessa merce lascia gli stabilimenti della nostra Società ovvero alla consegna. A seguito del passaggio dei rischi la nostra Società non risponde del perimento o della rovina della merce.

- In caso di ritardo da parte dell'Acquirente di presa in consegna della merce, il rischio, qualora non sia già passato in capo all'Acquirente ai sensi del capoverso precedente, si trasmetterà allo stesso alla data di consegna prevista.

- L'Acquirente è obbligato al pagamento integrale del prezzo in caso di danneggiamento o perimento della merce avvenuto dopo il passaggio allo stesso dei rischi.

11. Verifiche

- E' fatto obbligo all'Acquirente di verificare la conformità della merce e l'assenza di vizi entro 8 (otto) giorni dal ricevimento, e comunque prima di effettuare qualsiasi lavorazione aggiuntiva sulla stessa.

- Eventuali contestazioni saranno considerate valide solo se comunicate per iscritto mediante raccomandata a.r. entro 8 (otto) giorni dalla ricezione della merce.

- Eventuali vizi occulti dovranno essere denunciati per iscritto, mediante raccomandata a.r., entro 8 (otto) giorni dalla scoperta.

- In ogni caso nessuna denuncia per vizi, difetti o non conformità sarà valida se effettuata oltre un anno dalla consegna.

- Eventuali denunce dovranno essere dettagliate e specifiche, indicare esattamente i difetti riscontrati e, su richiesta della nostra Società, dovranno anche comprendere la restituzione del prodotto difettoso a proprie spese, al fine di consentire le verifiche del caso.

12. Garanzie

- La nostra Società garantisce la conformità dei prodotti: per conformità dei prodotti si intende che essi corrispondano per qualità e tipo a quanto stabilito nel contratto e che siano esenti da vizi che possano renderli non idonei all'uso cui sono destinati. I campioni, le indicazioni contenute nei depliant o le informazioni risultanti da altro materiale pubblicitario non sono vincolanti e non contengono alcuna promessa di qualità in relazione ai prodotti.

- La nostra Società non si assume alcuna responsabilità circa la conformità del prodotto alla normativa di Paesi stranieri ove sarà utilizzato il prodotto o destinato, circa eventuali usi speciali, circa gli usi abitualmente previsti nel Paese di destinazione.

- La garanzia avrà una durata di un anno dalla consegna.

- Sulle quantità l'Acquirente riconosce alla nostra Società di accettare quantità di fornitura determinate dalle minime quantità produttive nel caso di ordini riferiti a prodotti non disponibili a magazzino e a multipli interi delle unità di vendita per quanto concerne i materiali gestiti a magazzino.

- La garanzia per i vizi è limitata ai soli vizi dei prodotti dipendenti da difetti di materiale o di lavorazione riferibili alla nostra Società, e non si applica in caso di difetti di installazione o non corretto uso da parte dell'Acquirente. Sarà onere dell'Acquirente fornire alla nostra Società la prova di aver effettuato una corretta installazione o uso.

- La garanzia non si estende a difetti che siano riconducibili a richieste dell'Acquirente, a richieste di imprese terze incaricate dello stesso, alle lavorazioni successive, all'assemblaggio, all'installazione, alle caratteristiche della struttura, o ad altre cause che non sono oggetto della nostra fornitura.

- La nostra Società non risponde dei difetti di conformità dovuti all'usura normale di quelle parti che, per loro natura, sono soggette ad una rapida e continua usura.

- In generale, in nessun caso la nostra Società risponde per difetti di conformità che abbiano la loro causa in un fatto successivo al passaggio dei rischi all'Acquirente ai sensi dell'art. 10.

13. Contenuto della garanzia

- In caso di contestazione dei vizi nei termini e con le modalità di cui all'art. 11, la nostra Società eseguirà una verifica del prodotto in contestazione non appena lo stesso verrà inviato presso il nostro stabilimento, a spese dell'Acquirente; in caso di impossibilità di spedizione, la nostra Società effettuerà sopralluogo, a spese dell'Acquirente. All'esito delle verifiche la nostra Società redigerà un verbale contenente il dettaglio degli accertamenti eseguiti.

- Nel caso in cui saranno accertati dalla nostra Società i vizi o i difetti contestati, provvederemo, gratuitamente, a nostra discrezione:

a) alla riparazione;

b) alla sostituzione mediante la fornitura gratuita Porto Franco dei prodotti dello stesso genere e quantità di quelli risultati non conformi o difettosi, entro un termine ragionevole. Prima della sostituzione della merce l'Acquirente dovrà restituirci la merce difettosa.

- La sostituzione s'intende solo in relazione al singolo pezzo danneggiato e non all'intera partita.

- Non è dovuto alcun risarcimento danni; in particolare l'Acquirente non potrà avanzare altre richieste di risarcimento del danno, di riduzione del prezzo o di risoluzione del contratto.

- In nessun caso la nostra Società risponde per danni indiretti o consequenziali, per danni da mancata o ridotta produzione, anche rispetto a già pattuiti termini di consegna.

14. Riserva di proprietà

- La merce resta di proprietà della nostra Società fino al completo pagamento del prezzo.

- Nel caso venga esercitata la riserva di proprietà da parte della nostra Società, l'Acquirente presta fin da ora il consenso a consentirci l'accesso presso i luoghi dove è depositata la merce e il diritto a ritirare la merce di nostra proprietà.

- Fino a quando sussiste la riserva di proprietà è fatto divieto all'Acquirente, senza il consenso scritto della nostra Società, di costituire pegno o di vendere a terzi la merce di nostra proprietà.

- E' fatto obbligo all'Acquirente di comunicarci tempestivamente per iscritto eventuali pignoramenti o sequestri della merce di nostra proprietà e di dichiarare all'Ufficiale Giudiziario il nostro diritto di proprietà sulla suddetta merce, al fine di consentirci di esercitare le azioni legali necessarie.

- In caso di omessa o mancata tempestiva comunicazione, le spese legali relative ai procedimenti da noi sostenuti saranno a carico dell'Acquirente.

15. Divieto di cessione

- Il presente contratto e i diritti da esso derivanti non potranno, in tutto o in parte, essere ceduti dall'Acquirente, senza il consenso scritto della nostra Società.

16. Forma, esclusività e nullità

- Qualsiasi modifica al presente contratto non sarà valida se non fatta per iscritto ed approvata dalla nostra Società.

- L'eventuale nullità di una qualsiasi delle clausole previste nel presente contratto non comporterà la nullità dell'intero contratto, il quale andrà integrato ed interpretato nella sua globalità. Le parti si impegnano a sostituire la clausola nulla o inefficace con una clausola che tenga conto e consenta di realizzare lo scopo economico che le parti, il contratto e le condizioni generali si erano prefissati.

17. Obbligo di riservatezza

- L'Acquirente si obbliga a mantenere riservate tutte le notizie e le informazioni di carattere tecnico (disegni, prospetti tecnici, documentazione, formule, corrispondenza etc.) ricevute dalla nostra Società o apprese in esecuzione del presente contratto.

18. Risoluzione

- La nostra Società potrà risolvere il presente contratto, senza preavviso, mediante dichiarazione della propria volontà di risoluzione, comunicata per iscritto alla Società acquirente mediante raccomandata a.r., fax o mail, al verificarsi di uno dei seguenti eventi:

a) il mancato pagamento, parziale o totale, di quanto dovuto dalla Società acquirente secondo i tempi e le modalità previste nel presente contratto, salvo che la nostra Società non si avvalga della facoltà di chiedere l'adempimento del contratto, in ogni caso con pagamento dell'importo stabilito nel presente contratto, e previa determinazione dei termini delle consegne ripartite, oltre al risarcimento del danno;

b) In caso di dichiarazione di fallimento della Società acquirente o nel caso in cui la stessa venga sottoposta ad una procedura concorsuale;

c) in tutti gli altri casi previsti dagli artt. 1453 e segg. del codice civile.

19. Legge applicabile

- Per tutto quanto non espressamente previsto dalle presenti condizioni generali si applica la legge italiana e gli artt. 1470 e seguenti del codice civile italiano.

20. Foro competente

- Per tutte le controversie che dovessero sorgere in relazione all'esistenza, validità interpretazione, esecuzione e risoluzione del presente contratto sarà competente in via esclusiva il Foro di Milano.

21. Comunicazioni

- Tutte le comunicazioni riguardanti questo contratto devono essere fatte per iscritto, e si intenderanno validamente effettuate se inviate a mezzo raccomandata a.r. o a mezzo e-mail certificata ai seguenti indirizzi: Sapa Building Systems S.p.A, Via Fonchielli 3, 20063 Cernusco sul Naviglio (MI) - sapabuildingsystems@peccasapysystems.it

22. Privacy

- Ai sensi del D.Lgs. n.196 del 30.6.2003 entrambe le Società dichiarano di aver ricevuto informativa, ed autorizzano fin da ora ogni trattamento nonché comunicazione e diffusione dei dati, anche sensibili, necessari per la conclusione del presente Contratto di fornitura.

- Entrambe le parti si impegnano altresì a provvedere a propria cura e spese ad ogni adempimento del sopra citato decreto legislativo per soggetti terzi di propria competenza che, nel corso del rapporto contrattuale di cui trattasi, dovesse rendersi necessario per l'espletamento dell'incarico ricevuto.

23. Norme tecniche e responsabilità del produttore

- Per ciò che concerne le caratteristiche dei prodotti della nostra Società, essi sono conformi alla legislazione, alle norme tecniche vigenti in Italia e alle norme di prodotto specifiche al momento della conclusione del contratto.

- L'Acquirente si assume per intero il rischio di un'eventuale difformità tra le norme italiane e quelle del Paese di destinazione dei prodotti, tenendo indenne la nostra Società da ogni eventuale richiesta di risarcimento danni o sanzione o altra conseguenza economica.

- La nostra Società garantisce le prestazioni dei prodotti di sua fabbricazione solo ed esclusivamente in relazione ad usi, destinazioni, applicazioni, tolleranze da essa espressamente indicati.

- L'Acquirente non è autorizzato a disporre dei prodotti forniti dalla nostra Società in modo non conforme alle indicazioni di cui al punto precedente.



Sapa Building Systems S.p.A..
Via A. Ponchielli 3, 20063
Cernusco sul Naviglio (MI)
T: + 02 92 42 91
F: 02 92 42 94 96
www.domal.it

