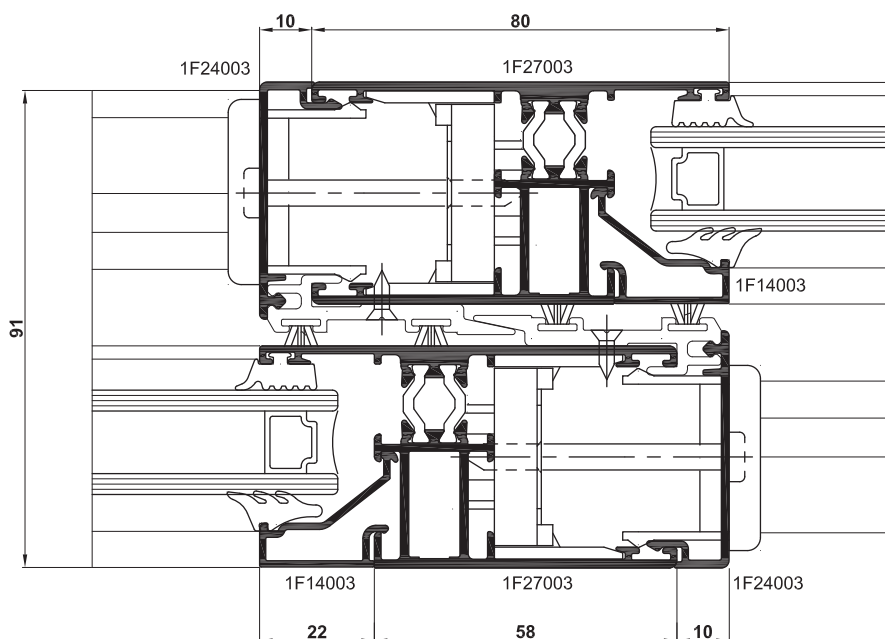

Original Systems®

**Teknowindow****WIN** 90s^{TT} SYSTEM - **WIN** 90s SYSTEM

Scorrevole - Sliding

Un solo sistema, progettato organicamente sia nei profilati sia negli accessori e nelle guarnizioni, basta per rispondere a tutte le esigenze dimensionali, tecnologiche ed architettoniche che il mercato richiede.

One single system, organically designed for profiles, accessories and weatherstrips, is enough to fulfill the dimensional, technological and architectural demands of the market.

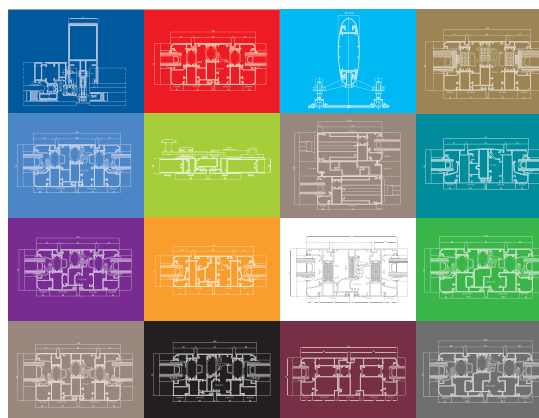

Sapa Profili Srl

sapa:

WIN 90s^{TT}
SYSTEM

WIN 90s
SYSTEM

Finestre e porte scorrevoli con e senza taglio termico
Windows and sliding doors with or without thermal break

About the Sapa Group

Sapa develops, manufactures and markets value added profiles, profile-based building systems and heat-exchanger strip in the light-weight material aluminium and is one of the world's leading manufacturers.

Sapa's business concept is based on close co-operation with its customers, who are primarily located in Europe, North America and Asia. The largest customer segments are the construction, transport, domestic and office, and engineering sectors.

Sapa is organised into six Business Areas: Profiles North Europe, Profiles Central Europe, Profiles South Europe, Profiles North America, Building System and Heat Transfer.

Sapa Profiles

Sapa is the world's leading producer of extruded aluminium profiles and maintains extensive operations in the value-added fabrication of profiles.

The company has 111 presses and more than 12.000 employees and production facilities in 18 countries: Belgium, China, Denmark, France, Germany, Hungary, Italy, Lithuania, Mexico, the Netherlands, Poland, Portugal, Romania, Slovakia, Spain, Sweden, the United Kingdom and the United States, plus sales representation in a number of additional countries.

With footprints in North and Central America, Europe and Asia we can serve customers on a worldwide basis.

Sapa Profili Srl

With 3 plants in Italy and the support of the rest of the group, Sapa Profili Srl is one of the largest extrusion companies within Italy.

Soft- and hard-alloy aluminium extrusions, standard rod and bars, seamless tube (round or shaped), simple or complex aluminium extrusion profiles (drawings), high fin ratio, tight tolerances with superior surface finish quality, or other demanding high-tech applications... There is a simple solution to almost any design problem: aluminium profiles by Sapa. The solutions are based on our unique experience in extrusion and our focus on the local market.

Sapa Profili Srl strategy is providing its customers with expertise, high quality and resources, releasing capacity to allow them to concentrate on their core operations. It's all about creating competitive, comprehensive solutions.

Il gruppo Sapa

Sapa sviluppa, produce e commercializza profili a valore aggiunto, profili per l'edilizia e scambiatori di calore in alluminio. Sapa è un leader tra i produttori nel mondo.

Un elemento determinante per il concetto di business di Sapa è la stretta collaborazione con il cliente maggiormente basati in Europa, Nord America ed Asia. I segmenti di mercato maggiori sono quelli dell'edilizia, il settore trasporti, casa ed uffici ed il settore della meccanica.

La Sapa è suddivisa in sei aree: Profili Nord Europa, Profili Europa centrale, Profili Sud Europa, Profili Nord America, Sistemi per l'edilizia ed il settore per gli scambiatori di calore.

Sapa Profili

Sapa è il maggior produttore di profili estrusi al mondo.

Questa nuova azienda dispone di 111 presse con oltre 12.000 dipendenti e con centri di produzione in 18 paesi: Belgio, Cina, Danimarca, Francia, Germania, Ungheria, Italia, Lituania, Messico, Olanda, Polonia, Portogallo, Romania, Slovenia, Spagna, Svezia, Gran Bretagna e negli stati uniti oltre ad avere rappresentanti commerciali in altri paesi.

Grazie alla presenza in America del Nord e Centrale, Europa ed Asia, possiamo servire i clienti in tutto il mondo.

Sapa Profili Srl

Con i 3 stabilimenti produttivi in Italia ed il supporto del resto del gruppo la Sapa Profili Srl diventa uno dei maggiori estrusori in Italia.

Estrusioni di alluminio in lega leggera o dura, profili standard o barrame, tubi tondi o a disegno senza saldature, profili estrusi semplici o complessi a disegno, elevato rapporto di alettatura, tolleranze ristrette con qualità superficiale elevata o qualsiasi altra esigenza per applicazioni high tech... esiste una semplice soluzione a quasi tutte le esigenze di design: profili in alluminio Sapa. Le soluzioni basano sulla nostra esperienza unica e focalizzata sul mercato locale..

La strategia di Sapa Profili Srl è quella di fornire al cliente competenza, qualità superiore e risorse, per permettere loro di concentrarsi sulle proprie operazioni essenziali. Plasmiamo il futuro creando soluzioni comprehensive e competitive.

sapa:



Teknowindow
Scorrevole - Sliding

Sapa keys to Build the future

Since its beginnings Sapa has been recognized as an innovator. Through the years, we've balanced experience with innovation. We've listened to our customers, and we are dedicated to providing the tools our customers need to succeed.

Following this spirit, in the market of B&C Sapa offers a comprehensive line of architectural aluminum building products and systems for residential and non-residential buildings framing systems, windows and curtain wall systems.

In Italian B&C market, Teknowindow offers the most complete and advanced technological solution to construct doors and windows.

The primary value of Teknowindow system is the capability to propose a complete system, able to satisfy with compatible profiles, accessories and gaskets all the markets needs, both for its technical and architectural characteristics.

From the smallest Win54 to the largest Win140s sections, from the "cold" to the thermal-break solutions (up to class 1.0), from the various types of opening (casement window, tilt-and-turn window, pivoting window, sliding window, lifting-sliding window, etc.) to the different aesthetic forms (squared, blunt, rounded, unframed, etc.), this system is able to satisfy whatever need.

High performance levels and manufacturing and assembling simplicity make this a state-of-the-art system in the Italian and foreign market.



Le chiavi Sapa per costruire il futuro

Fin dalle sue origini, Sapa è stata riconosciuta come innovatrice. Attraverso gli anni, abbiamo equilibrato l'esperienza con l'innovazione. Abbiamo ascoltato i nostri clienti e ci siamo dedicati a fornir loro i mezzi necessari per avere successo.

Seguendo questo spirito, nel mercato dell'edilizia, Sapa offre una completa linea di prodotti architettonici in alluminio e sistemi strutturali per edifici residenziali e non, finestre e pareti divisorie.

Nel mercato dell'edilizia, il sistema Teknowindow offre le soluzioni tecnologiche più complete ed avanzate per costruire porte e finestre.

Il pregio principale del sistema Teknowindow è dato dalla capacità di proporre un sistema completo, in grado di soddisfare con profilati, accessori e guarnizioni compatibili tra loro, tutte le esigenze del mercato, sia per quanto riguarda le caratteristiche tecniche che quelle architettoniche.

Dalle sezioni più piccole della Win54 a quelle maggiori della Win140s, dalle soluzioni "fredde" a quelle a Taglio Termico (sino alla classe 1.0), dai vari tipi di apertura (a battente, ad anta-ribalta, a bilico, a scorrevole, ad alza-e-scorri, ecc.) alle differenti forme estetiche (squadrata, smussata, arrotondata, scorniciata, ecc.), questo sistema è in grado di soddisfare ogni necessità.

Livelli prestazionali elevati, uniti alla facilità di lavorazioni e di montaggio, ne fanno un sistema all'avanguardia nel panorama dell'edilizia in Italia ed all'estero.

sapa:



Teknowindow
Scorrevole - Sliding

Original Systems®
sapa:

Le serie dei sistemi di Sapa

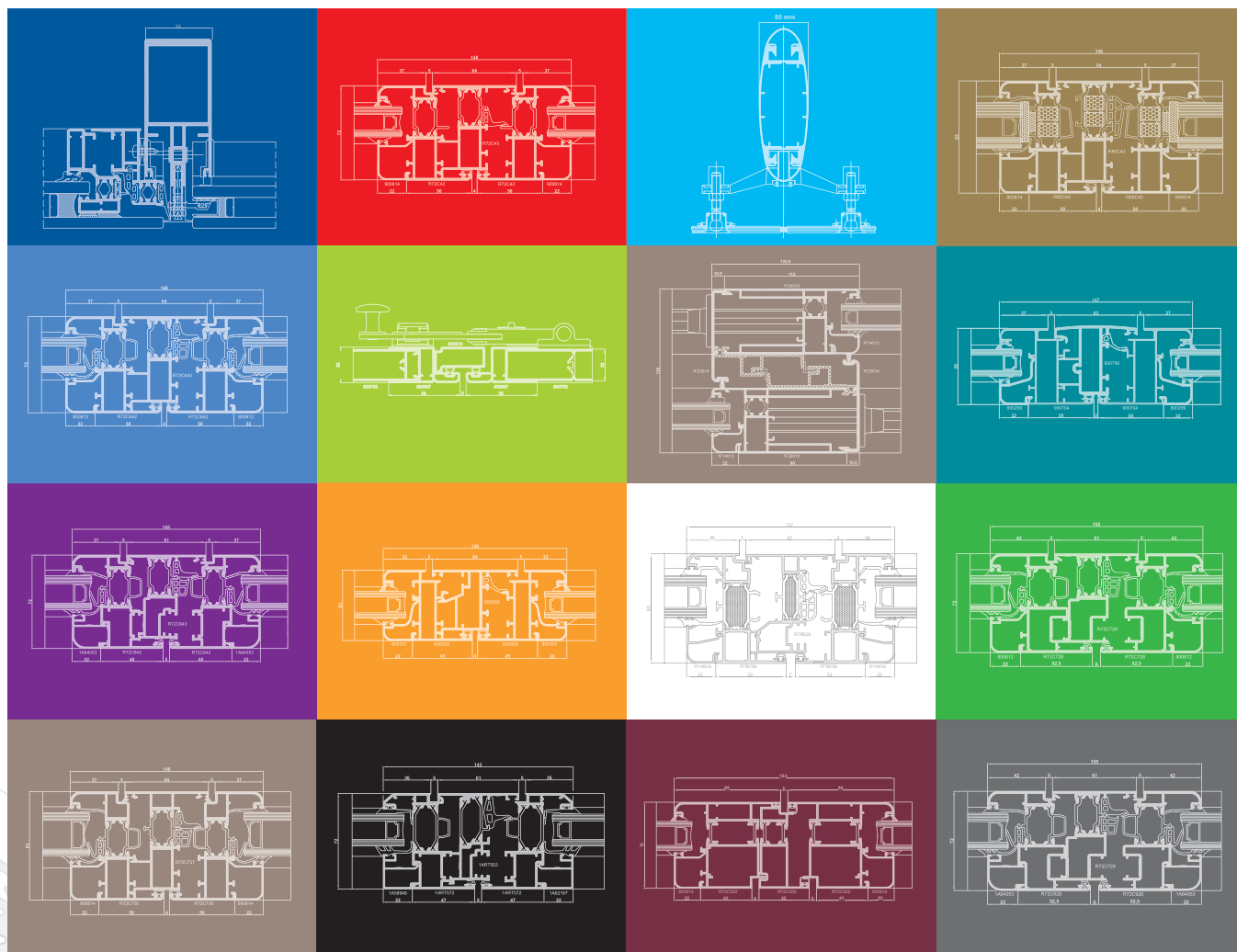

Scegliere con **serenità**

sapa:
Creiamo il futuro

sapa:

Original Systems®

... scegliere con serenità

Original Systems Sapa non è soltanto un profilo in alluminio: è una soluzione completa per tutti gli attori della filiera, con l'obiettivo di fornire il miglior prodotto, col più alto valore aggiunto, dalla bauxite al serramento.

L'assistenza tecnica pre e post vendita, i certificati delle prestazioni dei serramenti, la formazione della Scuola del Serramento di Bareggio (MI), i software di calcolo, le soluzioni Autocad, gli opuscoli tecnici, i cataloghi, la comunicazione ed una capillare e competente Rete di Distribuzione Original Systems Sapa vi danno la serenità di aver fatto la scelta migliore.

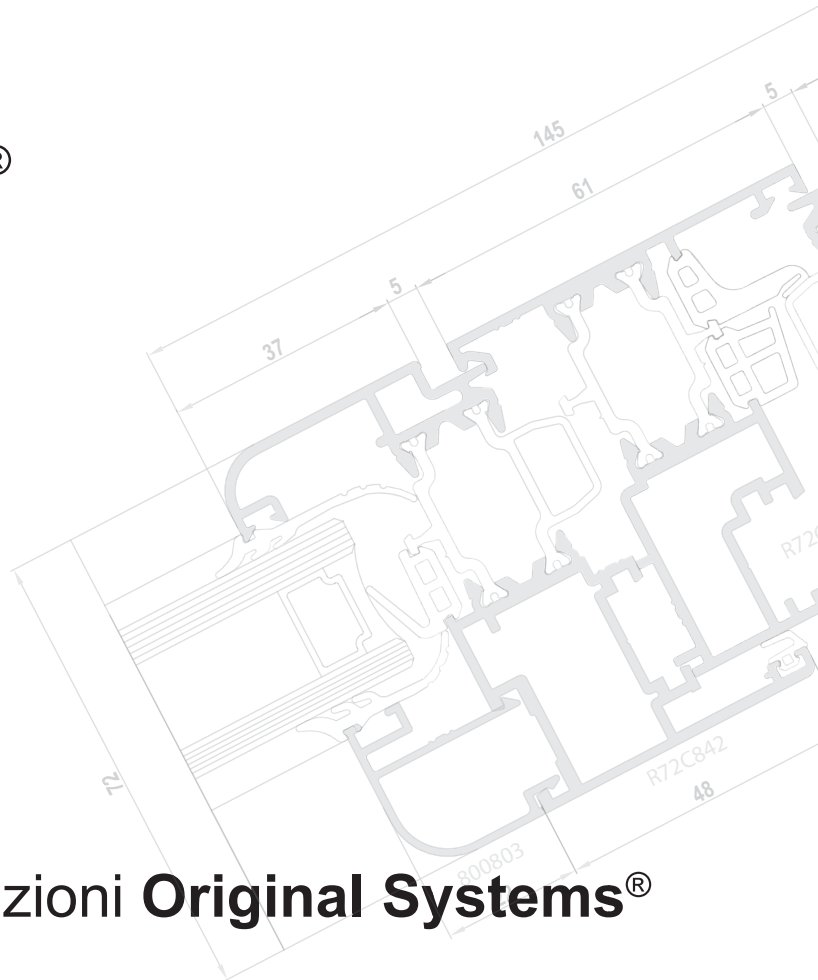

soluzioni Original Systems®

Sistema R^{TT}

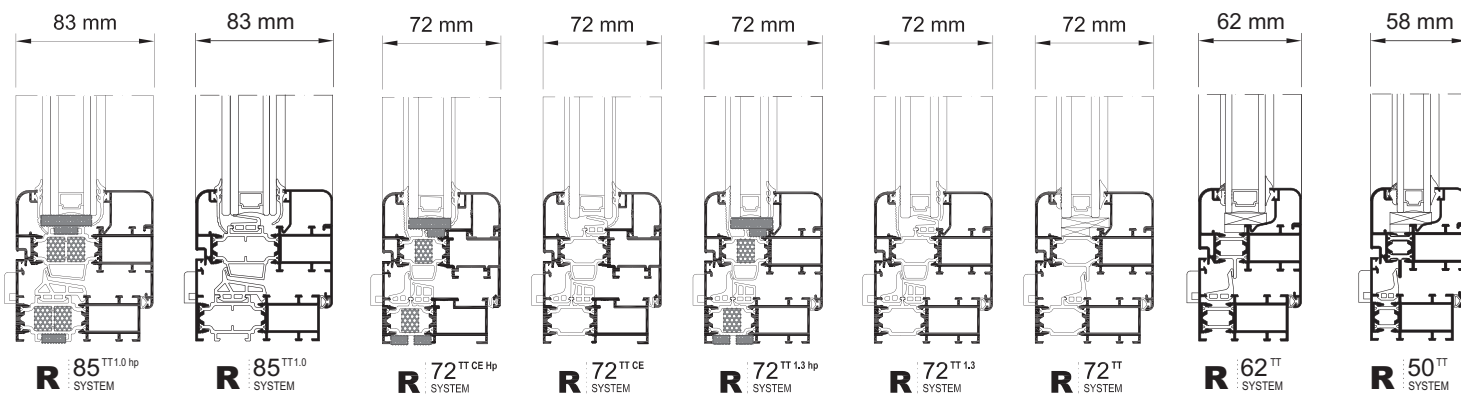

Alfil *next*

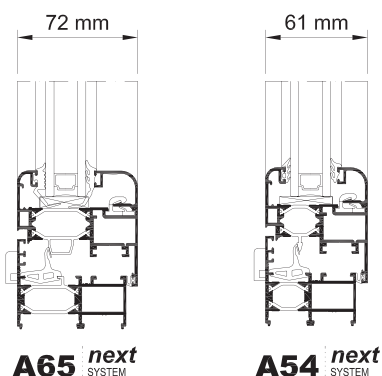

Sistema R

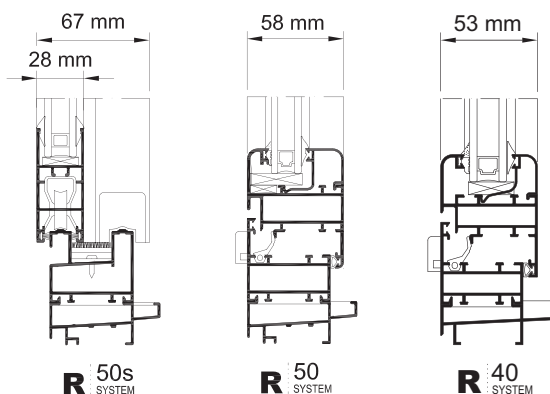

Mr. Hide SYSTEM

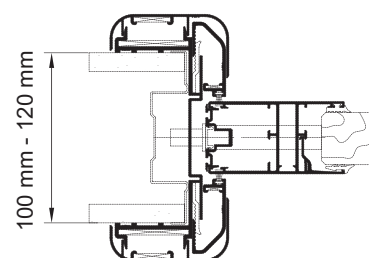

Teknowindow Battente

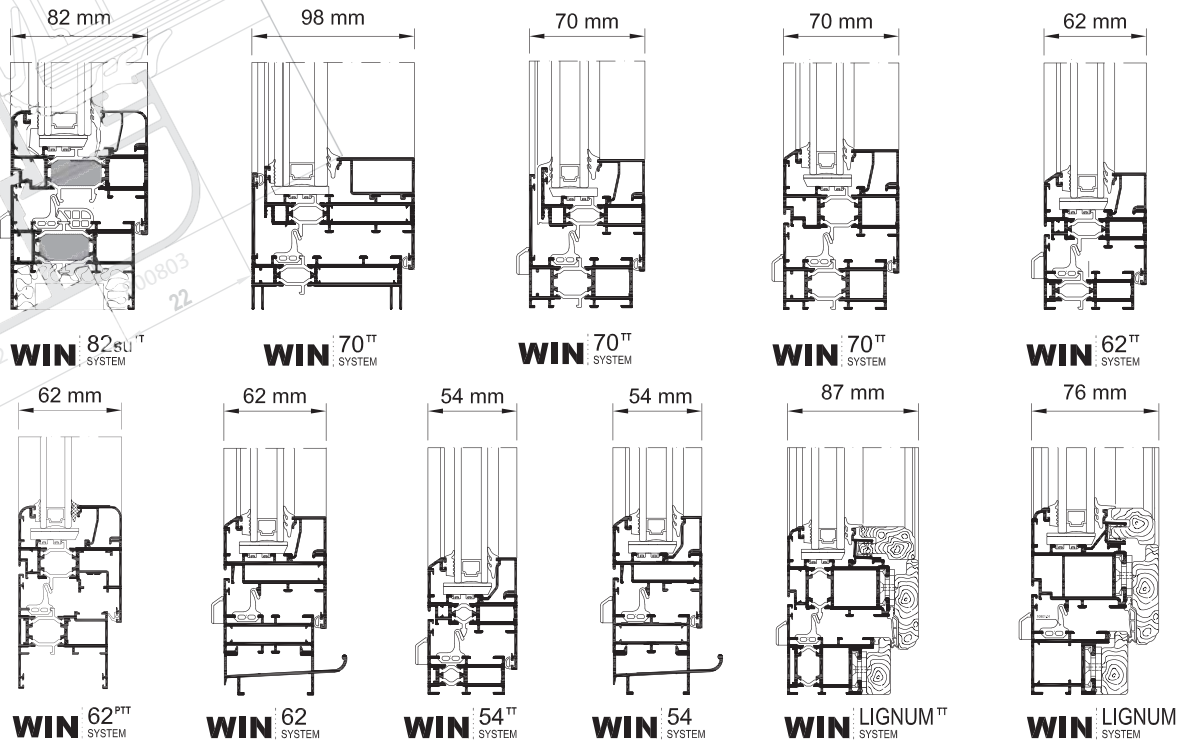

Teknowindow Scorrevole

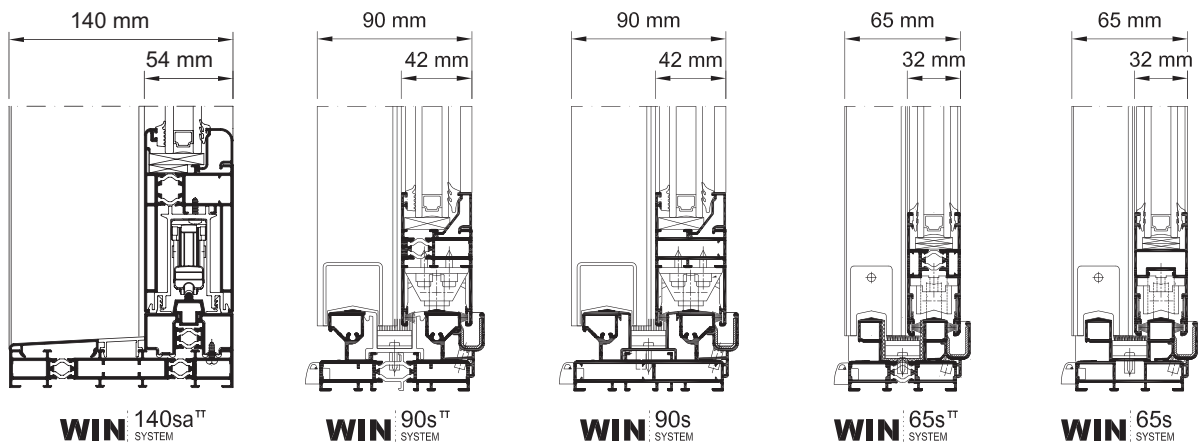

Sistemi Oscuranti

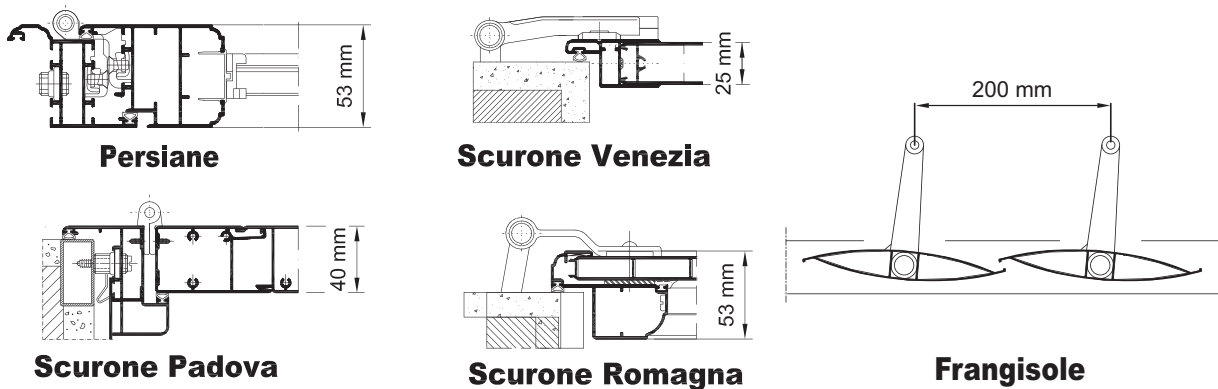

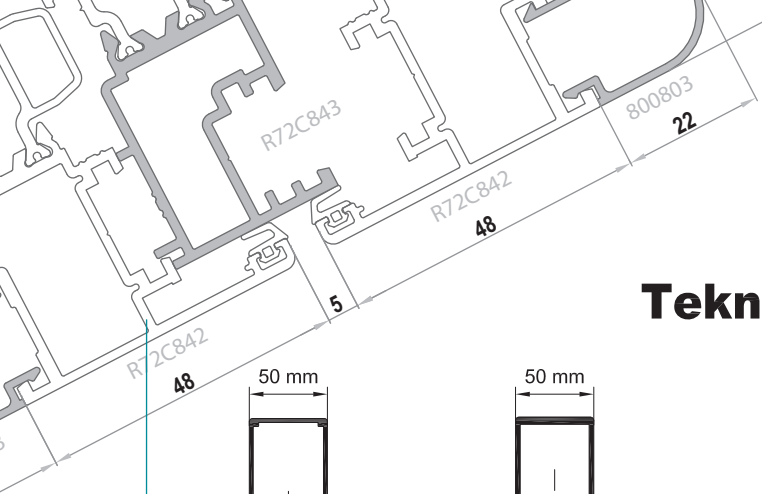

Teknowall

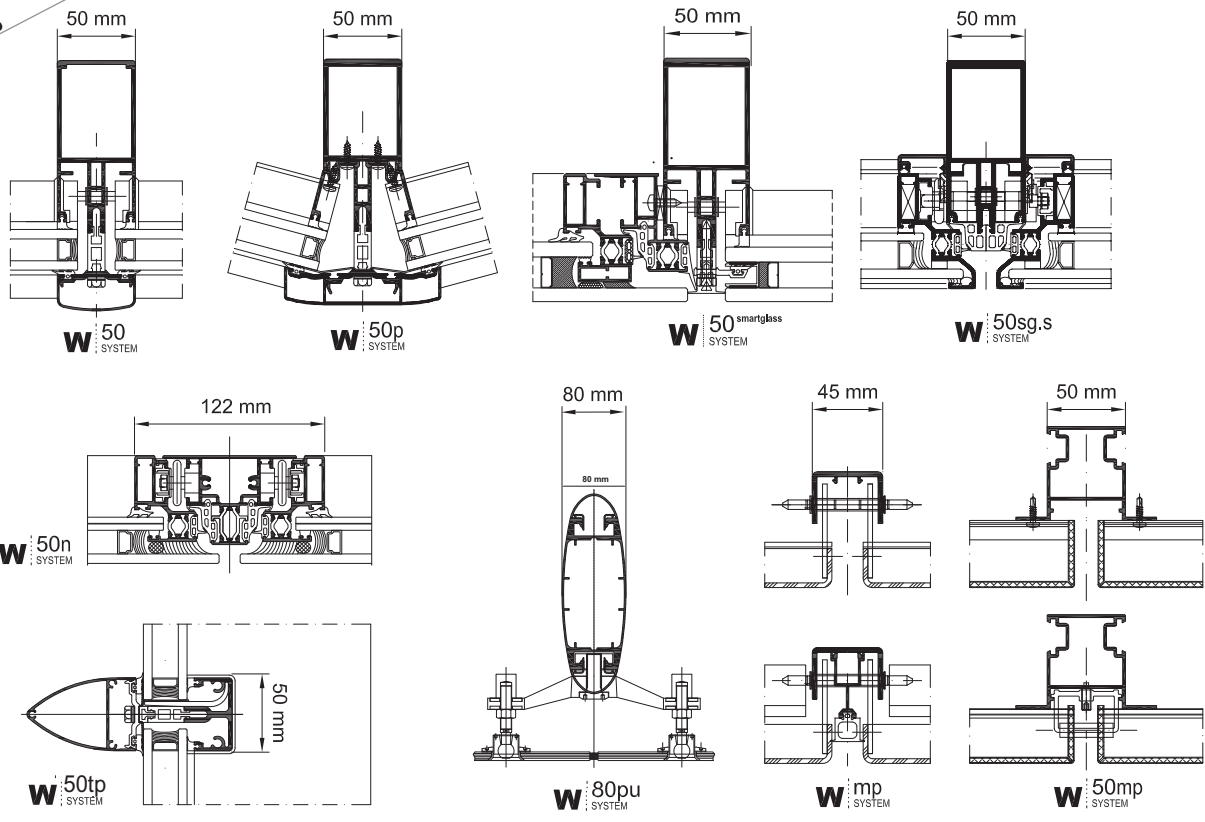

Portoni

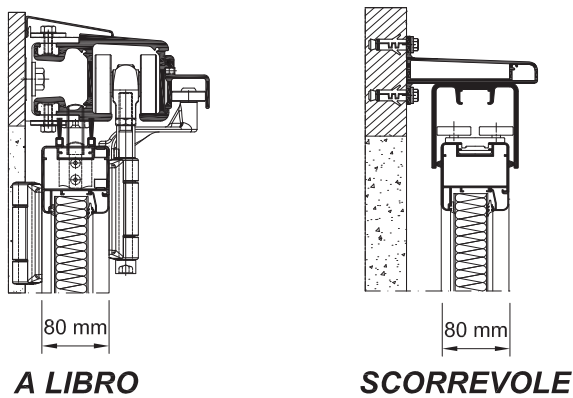

Veranda a Libro

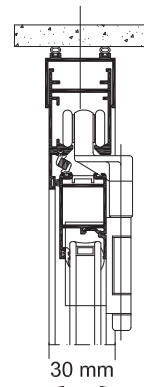

GR 14 SYSTEM

plus® SYSTEM

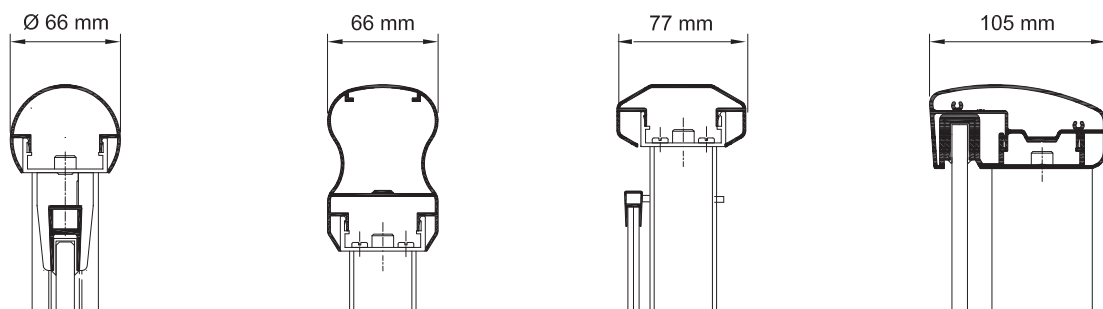

RINGHIERE E BALCONI

I Profilati:

Estrusi in lega di alluminio primario da lavorazione plastica EN AW 6060 UNI-EN 573-3 sottoposti ad un processo di trattamento termico applicato secondo Normativa UNI EN 755-2 (bonifica con tempra in aria alla pressa, seguita da invecchiamento artificiale) per ottenere lo stato T5. Per dettagli tecnici vedere pagina F1-90s-A.04

Trattamenti superficiali:

I trattamenti superficiali di ossidazione anodica, elettrocolorazione e di verniciatura eseguiti negli impianti di proprietà Sapa, sono nel rispetto di quanto previsto dalle normative richieste dai marchi Qualanod (per ossidazione) e Qualicoat (per la verniciatura).

Vetratura:

La scelta ed il tipo di vetro sarà in funzione del suo campo di impiego, per il montaggio attenersi scrupolosamente alle prescrizioni dei produttori.

Il Sistema consente l'inserimento di vetri aventi spessori da 4 a 20 mm per Win 65; da 4 a 29 mm per Win 90; da 16 a 25 per Win 90 vetro ad infilare; da 20 a 38 mm per Win 140sa.

Le guarnizioni di tenuta vetro sono in EPDM ed inseribili e sostituibili a serramento assemblato, studiate in vari spessori che, interpolati nel modo idoneo, garantiscono un'adeguata compressione sulla lastra di vetro. La tassellatura sarà effettuata con appositi tasselli di regolazione e spessoramento aventi posizioni nel serramento ideali e rinforzate. Solo la completa e totale osservanza della tecnica di vetratura potrà garantire uno scatto vincolante e sicuro del fermavetro e la garanzia di durata agli sforzi di normale utenza.

Calcolo dimensioni massime serramenti:

Nel definire le misure massime dei diversi tipi di serramento, si devono considerare oltre agli elementi costruttivi dell'infixo (sezione dei profilati e loro campi d'impiego, tipo di attacco al muro, spessore e tipo del vetro), le caratteristiche di utilizzo, nonché le varianti metereologiche (esposizione dell'infixo, velocità dei venti agenti nella zona, altezza dal suolo alla quale sarà installato l'infixo, ecc.).

Consigliamo a tal fine la consultazione delle prescrizioni Uncsaal.

Attrezzature:

Le attrezzature raccomandate (Comall e Tekna) sono state appositamente progettate e realizzate per le particolari caratteristiche del sistema e per l'applicazione specifica degli accessori a catalogo.

Peso dei profilati:

I pesi indicati sono puramente indicativi (peso teorico ricavato sullo spessore nominale del profilato); Le matrici di estrusione sono soggette ad un normale processo di usura che porta il peso dell'estruso da un minimo (matrice nuova) ad un massimo (matrice usurata al limite delle tolleranze dimensionali).

NB:

Il mancato impiego, anche parziale, dei prodotti originali, esclude qualsiasi possibilità di rivalsa nei confronti di Sapa.

Al fine di migliorare i propri prodotti, Sapa si riserva la facoltà di apportare, in qualsiasi momento e senza preavviso, le modifiche che riterrà opportuno.

I dati riportati su questo catalogo sono indicativi e non impegnativi.

The sections

These are extruded in primary aluminium alloy from EN AW 6060 UNI-EN 573-3 plastic manufacturing, subject to a thermal treatment, applied according to UNI EN 755-2 regulation (austempering through air tempering at the press, followed by artificial ageing) in order to achieve the T5 physical state.

For technical detail refer to page F1-90s-A.04

Surface treatments:

The surface treatments of anodization, electrocoloration and painting carried out in Sapa Italy plants, respect the regulations required by the brands: Qualanod (for anodization) and Qualicoat (for painting).

Glazing:

The choice and the type of glass will depend on its final use.

While assembling, it is essential to follow scrupulously the manufacturers' instructions.

With this System it is possible to insert glass with thickness of 4 to 20 mm for Win65; 4 to 29 mm Win 90; 16 to 25 mm for Win 90 glass insertion; 20 to 38 mm Win140sa.

The weatherstrips for the glass containment is in EPDM and is conceived in different thickness. If interpolated in the correct way, it assures a proper compression on the glass.

The plugging will be carried out through proper adjusting and shimming plugs, located in ideal and reinforced positions in the fastening. Only the full respect of the glazing technique will assure the proper functioning of the glass beading and will guarantee a long term resistance to the normal uses.

Window maximum dimensions:

During the definition of the maximum dimensions of the different sorts of windows, beside the structural elements of the frame (section, uses, juncture to the wall, thickness and sort of glass), the final use and the weather conditions (exposure of the window frame, speed of the wind in the area, distance from the ground where the frame will be installed, etc.) have to be taken into account.

To this purpose, we suggest to consult the Uncsaal regulations.

Equipment:

The recommended equipment (Comall and Tekna) has been planned and realized on purpose according to the particular characteristics of the system and to the specific application of the catalogue accessories.

Weight:

Any weight is shown just as an indication (theoretical weight made out of the nominal thickness of the section) The extrusion dies are subject to the natural wear and tear, therefore the section weight varies from a minimum when the dies is new, to a maximum weight when the die is at highest dimensional tolerances limits

NB:

Sapa declines any responsibility in case of use or partial use of non original products.

With the aim of improving it's products, Sapa reserves the possibility to make changes to this document at any moment and with no advise.

The data reported in this catalogue are indicative and not binding.

L'esecuzione del serramento dovrà prevedere tutte le operazioni necessarie per il buon funzionamento del "componente finestra" quali la sigillatura e il bloccaggio sicuro degli angoli, il fissaggio a muro adeguato e, necessariamente, l'utilizzo di accessori e guarnizioni originali. Le lavorazioni, proprio per garantire la giusta applicazione dei particolari, dovranno essere eseguite con attrezzature originali e collaudate sul sistema stesso. Gli scarichi dell'acqua e le asole di aerazione per vetri camera dovranno essere di dimensione e numero ottimale in funzione della dimensione e della tipologia del serramento.

The frame construction must include all the operations necessary for good working of the "window component", such as sealing and safe blocking of corners, suitable wall fixtures and the use of the original accessories and weatherstrips. In order to guarantee the correct application of the parts, works must be carried out with original equipment that has been tested on the system. The size and number of water drains and ventilation slots for double glazing must correspond to the size and type of window frame.

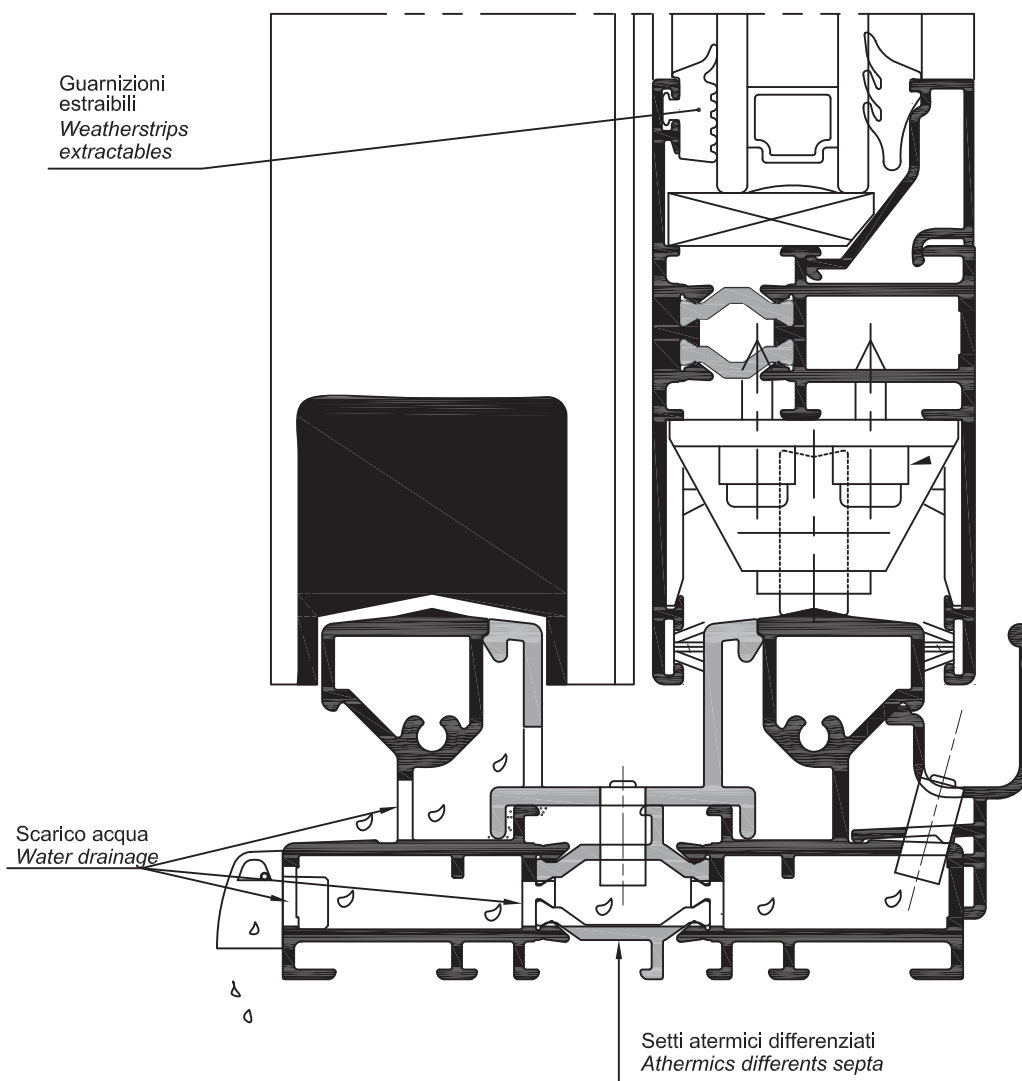

ACCESSORI DI ASSEMBLAGGIO E MOVIMENTO **ASSEMBLY AND MOVEMENT ACCESSORIES**

Gli accessori, brevettati, originali Teknowindow, sono frutto della collaborazione con le migliori aziende specializzate del settore. Sono realizzati con materiali equivalenti, per prestazioni e resistenza alla corrosione, a quelli dei telai; i perni sono in acciaio inox, le boccole ed i particolari di scorrimento sono realizzati in nylon rinforzato con bloccaggio del tipo a contrasto. Le squadrette di serraggio angoli, ad avvitare, a spinare ed a cianfrinare, sono realizzate con leghe di alluminio diverse secondo le esigenze del loro impiego.

The original patented Teknowindow accessories are the result of the collaboration with the best a specialized company in the sector.

They are constructed with materials of equivalent performance and corrosion resistance to the frames; the pins are in stainless steel, the bushes and sliding parts in reinforced nylon with blocking of the type with contrast.

The screwing, pinning and caulking corner joints are constructed with different aluminium alloys depending on their use

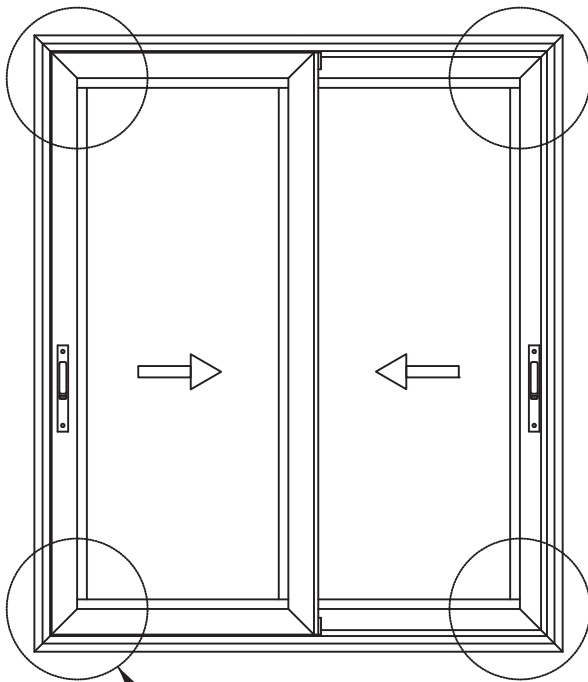

AVVERTENZE PER L'ASSEMBLAGGIO

1. Sigillare tutte le unioni tra profilati, nei tagli a 45° e nei collegamenti tra montanti e traversi
2. Sigillare in "A" per tutta la lunghezza del profilo
3. Le squadrette a cianfrinare e di allinamento battuta devono essere incollate con collante poliuretano monocomponente
4. Nei profilati a taglio termico, ove utilizzate squadrette a cianfrinare, devono essere prima incollate e poi cianfrinate. Cianfrinatura eseguibile anche con attrezzatura manuale (Art. M. 2001.00).
5. Le guarnizioni cingivetro interne ed esterne devono essere tagliate a 45° ed unite agli angoli con sigillante.
6. Le guarnizioni di battuta perimetrali devono essere tagliate a 45° ed unite sulla base degli angoli con collante cianoacrilico LOCTITE 406.

ASSEMBLY INSTRUCTIONS

1. Seal all the joints between sections, in the 45° cuts and in the connections between uprights and transoms.
2. Seal in position "A" for the all length of section
3. The caulking, levelling and rabbet alignment corner joints must be glued with monocomponent polyurethan adhesive.
4. In the thermal break section, if you use crimping corner joints, these must be glued and caulked. Caulking may also be carried out by hand (Art. M.2001.00).
5. The internal and external glass-clamping weatherstrips must be cut at 45° and united to the corners with sealer
6. The perimetral rabbet weatherstrips must be cut at 45° and united on the base of the corners with LOCTITE 406

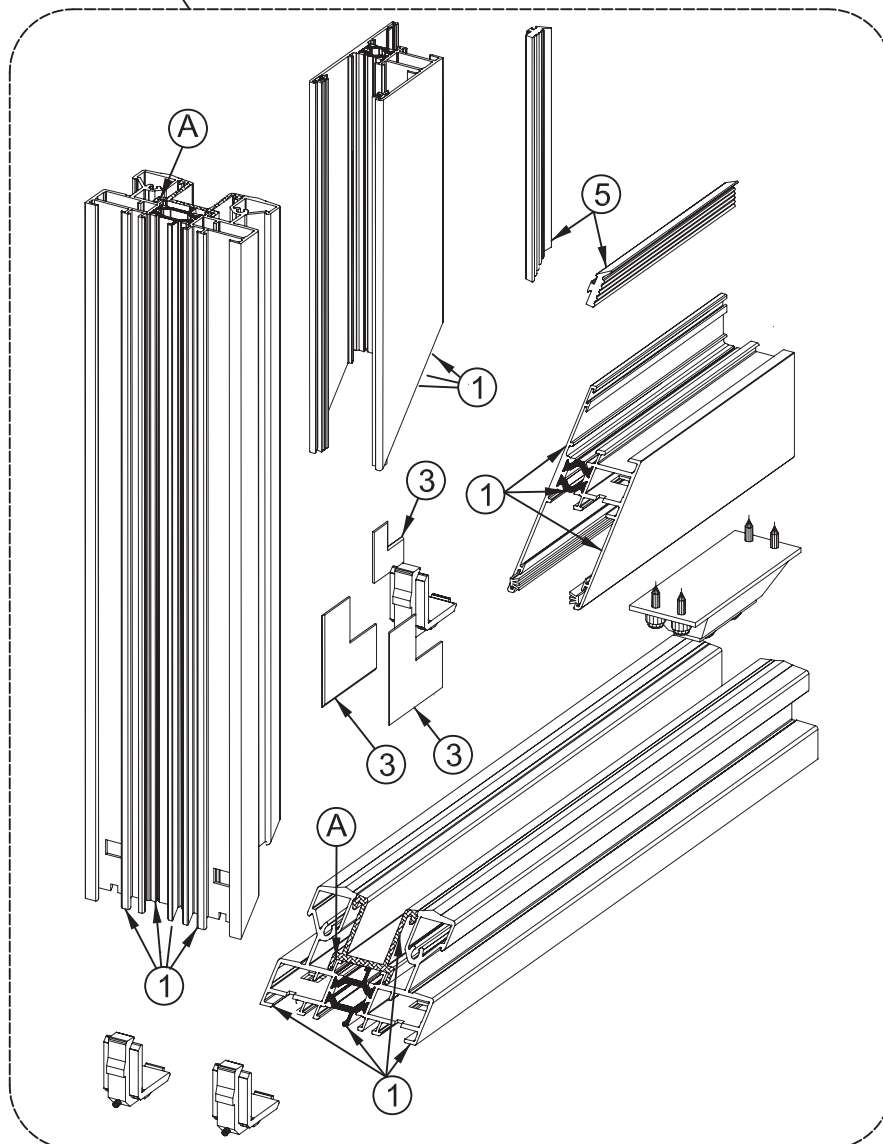

Una corretta posa in opera, evita spesso il decadimento delle prestazioni ottenute in laboratorio, curare in maniera appropriata la posa valorizza tutto il processo produttivo dalla progettazione all'installazione.

Fare una pulizia periodica con prodotti neutri riduce notevolmente i rischi di corrosione ed allunga sicuramente la vita dell'infisso. Per una corretta installazione, manutenzione e pulizia dei serramenti, Vi raccomandiamo di consultare le prescrizioni riportate sulle seguenti note tecniche UNCSAAL:

UX42 - "Guida alla posa in opera dei serramenti"

UX10 - "La pulizia delle superfici di serramenti e facciate continue"

A correct installation, often avoids the decay of the performances obtained in the laboratory. Taking appropriate care of the installation increases the value of the whole production process from the planning to the installation.

Cleaning periodically with neutral products reduces remarkably the corrosion risk and extends surely the life of the frame.

For a correct installation, maintenance and cleaning of the sections, we recommend you refer to the prescriptions quoted in the following technical notes of UNCSAAL UX42 and UX10



LEGHE IN ALLUMINIO DA BONIFICA - PROFILATI ESTRUSI
HEAT-TREATABLE ALUMINIUM ALLOYS - EXTRUSION SECTIONS

Leghe / Alloys		6060 UNI EN 573-3				
Composizione chimica normale / Normal chemical compos		Mg 0,4 Si 0,4 Fe 0,2				
Stato / State		0	T1	T5	T6	
Caratteristiche meccaniche <i>Mechanical Characteristics</i>	Carico di rottura a trazione <i>Ultimate tensile stress</i>	R _m N/mm ²	140 Max	120	185	205
	Carico al limite di snervamento <i>Yield point</i>	R _p N/mm ²	80 Max	50	145	165
	Allungamento <i>Elongation</i>	A %	20	16	11	10
Caratteristiche fisiche <i>Physical Characteristics</i>	Peso specifico <i>Specific weight</i>	Kg/dm ³	2,70			
	Conduttività termica a 20°C <i>Heat conductivity at 20°C</i>	W/ (cm °K)	≈ 2,09		≈ 1,75	
	Resistività elettrica a 20°C <i>Electrical resistivity at 20°C</i>	μΩ · cm	≈ 3,14		≈ 3,25	
	Coef. di dilatazione termica lineare da 20° a 200°C <i>Linear thermal expansion coefficient from 20° to 200° C</i>		24 · 10 ⁻⁶ K ⁻¹			

PRESTAZIONI AGLI AGENTI ATMOSFERICI
ATMOSPHERIC AGENTS PERFORMANCES

WIN 90s^{TT}
 SYSTEM

WIN 90s
 SYSTEM

Per garantire il massimo delle prestazioni in funzionalità e durata, il sistema TEKNOWINDOW è stato sottoposto ai collaudi prescritti dalle vigenti Normative europee ottenendo ottimi risultati

To guarantee the maximum functionality and wear, TEKNOWINDOW system has been tested according to the running european norms.

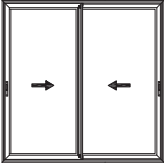
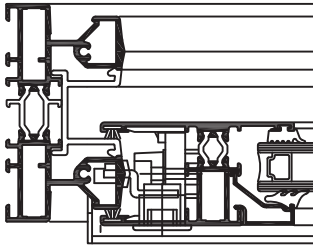
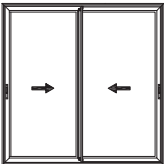
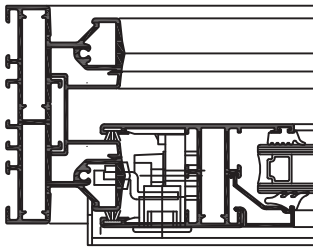
CERTIFICATI		CERTIFICATES						
Sistema System	Tipologia Windows and doors	Dimensioni Dimensions L x H mm	Risultati prove Test values			Sezioni Cross section	Laboratorio Certificato n° Laboratory Certificate nr.	
			Aria Air	Acqua Water	Vento Wind			
WIN 90s^{TT} SYSTEM		2200 x 2100	A3	E4	V3		ISTEDIL 428/96-A	
WIN 90s SYSTEM		2400 x 2200	A3	E4	V2a		ISTEDIL 631/97	

Tecnicamente, viene definito "a taglio termico" un profilato metallico che, una volta impiegato nella costruzione di un infisso, presenti il lato rivolto all'interno nettamente diviso dal lato esposto all'esterno per impedire lo scambio termico. Le due parti della sezione devono essere perciò separate da un materiale diverso, con bassi valori di conducibilità termica.

Il taglio termico del sistema Teknowindow, realizzato con barrette in poliammide rinforzato, si colloca su bassi valori di trasmittanza termica, in linea con i sistemi a taglio termico più avanzati.

Per evitare slittamenti dei vari componenti del profilato a taglio termico è prescritta la pre-zigrinatura dei particolari di bloccaggio prima dell'operazione meccanica di accoppiamento.

A metal section which, when used in the construction of a frame, has the side facing inwards clearly divided from that facing outwards to prevent heat exchange is technically defined as "thermal break". The two parts of the section must therefore be separated by a different material, with low conductivity values.

The thermal break of the Teknowindow system, produced with reinforced polyamide bars, is placed on low Uf values (heat transmission coefficient), in line with the most advanced thermal break systems.

To prevent the components of the thermal break section from slipping, it is advisable to pre-knurl the blocking parts before carrying out the mechanical coupling operation.

Tutti i profilati a taglio termico venduti da Sapa sono sempre riconoscibili.

Il marchio, impresso a laser è stato previsto per essere sempre visibile nel profilato assemblato come dalla figura sottostante

All thermal break sections are always recognizable.

The laser impressed brand is always visible on the assembled sections as you can see in the picture here under



Sapa non risponde di eventuali difetti imputabili ad accoppiamenti non eseguiti nei propri stabilimenti e/o dovuti all'utilizzo di macchine non idonee e/o mal regolate.

Sapa will not be responsible for any incidental defects due to couplings which have not been carried out in its own premises and/or due to the use of not proper and/or not well-regulated machines.

I valori di trasmittanza termica U_f sotto riportati sono i risultati di calcolo eseguito secondo la normativa UNI EN ISO 10077-2 e secondo normativa UNI EN 12412-2

The thermal performance values U_f hereunder reported are calculation results in accordance with the norm UNI EN ISO 10077-2 and in accordance with the norm UNI EN 12412-2

Nella porzione di tubolarità delimitata dalle barrette del taglio termico si assume:

- Il valore pari a 0,90 per l'emissività dell'alluminio verniciato
- Il valore pari a 0,30 per l'emissività dell'alluminio non verniciato

The equivalent thermal conductivity of the cavity between aluminium and polyamid bars is:

- 0,90 If the aluminium is painted
- 0,30 If the aluminium is mill finish

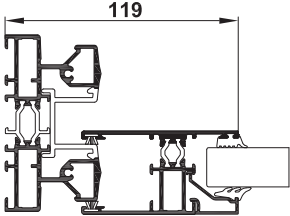
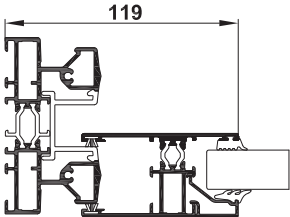
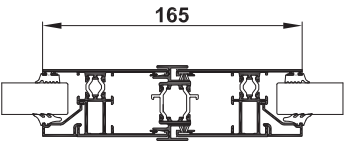
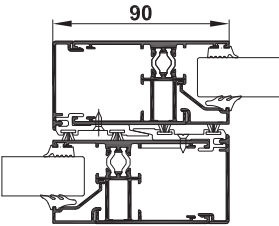
CERTIFICATI		CERTIFICATES					
Sistema System	Sezioni Cross section	Profilati Section	Risultati calcolo Calculus values		Laboratorio Certificato N°. Laboratory Certificate Nr°.	Risultati test in camera calda Hot box test values	Laboratorio Certificato N°. Laboratory Certificate Nr°.
			$U_f = W/m^2 \cdot K$	$\varepsilon = 0.9$ $\varepsilon = 0.3$		$U_f = W/m^2 \cdot K$	
WIN 90s ^{TT} SYSTEM		1F27003 1F27001	3,81	3,77	ITC 4725/RP/08		
WIN 90s ^{TT} SYSTEM		1F27003 1F27001				3,1	SGM S882KA03
WIN 90s ^{TT} SYSTEM		1F27003 1F27007 1F27003				2,32	SGM S882KA02
WIN 90s ^{TT} SYSTEM		1F27003 1F24003				2,8	SGM S882KA01

"Valido solo per il territorio ITALIANO"

"Applicable only for Italy"

Requisiti della prestazione energetica degli edifici

Decreto legislativo 29 dicembre 2006, n. 311

Disposizioni correttive ed integrative al decreto legislativo 19 agosto 2005, n. 192, recante attuazione alla direttiva 2002/91/CE, relativa al rendimento energetico nell'edilizia.

Stabilisce i valori massimi della trasmittanza termica dei vetri e delle chiusure trasparenti comprensive di vetri e profilati metallici.

Tabella 4a Valori limite della trasmittanza termica U delle chiusure trasparenti comprensive degli infissi espressa in W/m ² K			
Zona climatica	Dall' 1 gennaio 2006 U (W/m ² K)	Dall' 1 gennaio 2008 U (W/m ² K)	Dall' 1 gennaio 2010 U (W/m ² K)
A	5,5	5,0	4,6
B	4,0	3,6	3,0
C	3,3	3,0	2,6
D	3,1	2,8	2,4
E	2,8	2,4	2,2
F	2,4	2,2	2,0

Tabella 4b Valori limite della trasmittanza U dei vetri espressa in W/m ² K			
Zona climatica	Dall' 1 gennaio 2006 U (W/m ² K)	Dall' 1 gennaio 2008 U (W/m ² K)	Dall' 1 gennaio 2011 U (W/m ² K)
A	5,0	4,5	3,7
B	4,0	3,4	2,7
C	3,0	2,3	2,1
D	2,6	2,1	1,9
E	2,4	1,9	1,7
F	2,3	1,7	1,3

Il territorio nazionale è suddiviso nelle seguenti zone climatiche in funzione dei gradi-giorno, indipendentemente dalla ubicazione geografica:

Zona A - Comuni che presentano un numero di gradi-giorno non superiore a 600;

Zona B - Comuni che presentano un numero di gradi-giorno maggiore di 600 e non superiore a 900;

Zona C - Comuni che presentano un numero di gradi-giorno maggiore di 900 e non superiore a 1400;

Zona D - Comuni che presentano un numero di gradi-giorno maggiore di 1400 e non superiore a 2100;

Zona E - Comuni che presentano un numero di gradi-giorno maggiore di 2100 e non superiore a 3000;

Zona F - Comuni che presentano un numero di gradi-giorno maggiore di 3000.

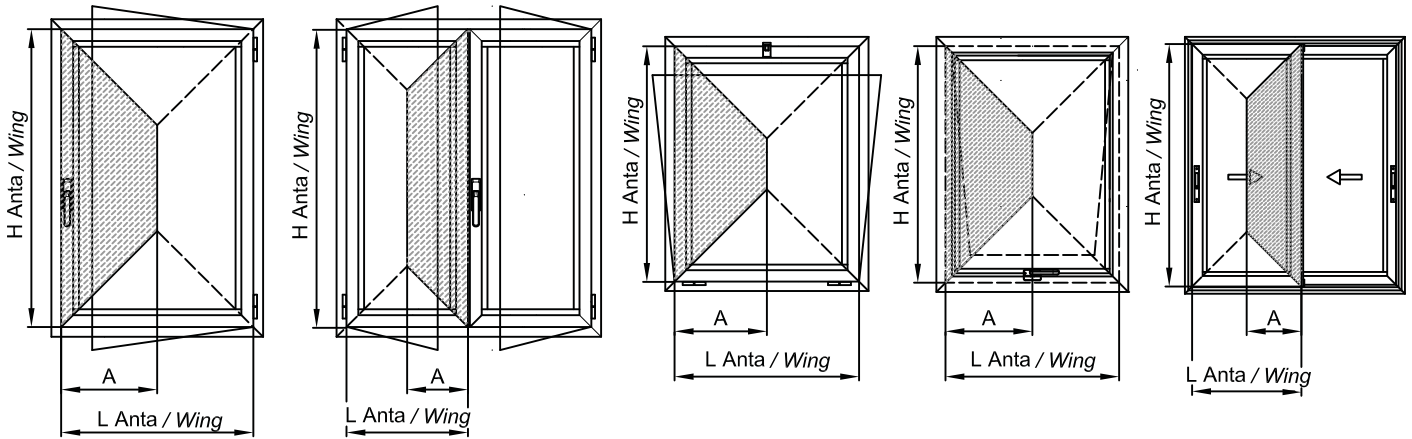

I grafici di seguito riportati sono stati ottenuti con la seguente formula:

The graphs below were created using the following formula:

$$J(\text{cm}^4) = \frac{q(\text{Kgf/cm}^2) \times H^4(\text{cm}) \times A(\text{cm})}{1920 \times E(\text{Kgf/cm}^2) \times f(\text{cm})} \times \left[25-40 \times \left(\frac{A}{H}\right)^2 + 16 \times \left(\frac{A}{H}\right)^4 \right]$$

Dove:

- Jx = Momento d'inerzia (cm⁴)
- q = Carico del vento (Kgf/cm²)
- H = Altezza anta (cm)
- A = Larghezza anta : 2 (cm)
- E = Modulo di elasticità (Kgf/cm²)
- f = Freccia (cm)

Were:

- Jx = Moment of inertia (cm⁴)
- q = Wind load (Kgf/cm²)
- H = Wing height (cm)
- A = Wing/2 width (cm)
- E = Coefficient of elasticity (Kgf/cm²)
- f = Camber (cm)

Essa è riferita al dimensionamento delle ante rispetto all'inerzia del profilato, per cui verificare sempre che il peso delle ante sia compatibile con la portata degli accessori impiegati, cerniere ecc. Inoltre verificare sempre che la freccia dei profilati sia compatibile con il vetro impiegato.

This refers to the size of the wings compared with the section inertia so always make sure the weight of the wings is compatible with the load of accessories hinge etc. used. Also always check that the section camber is suitable for the glass used.

CARICO DEL VENTO/ WIND LOAD : q= 50 Kg/m²
 f max H/200 (Vetro in lastra singola/ Single pane glass)

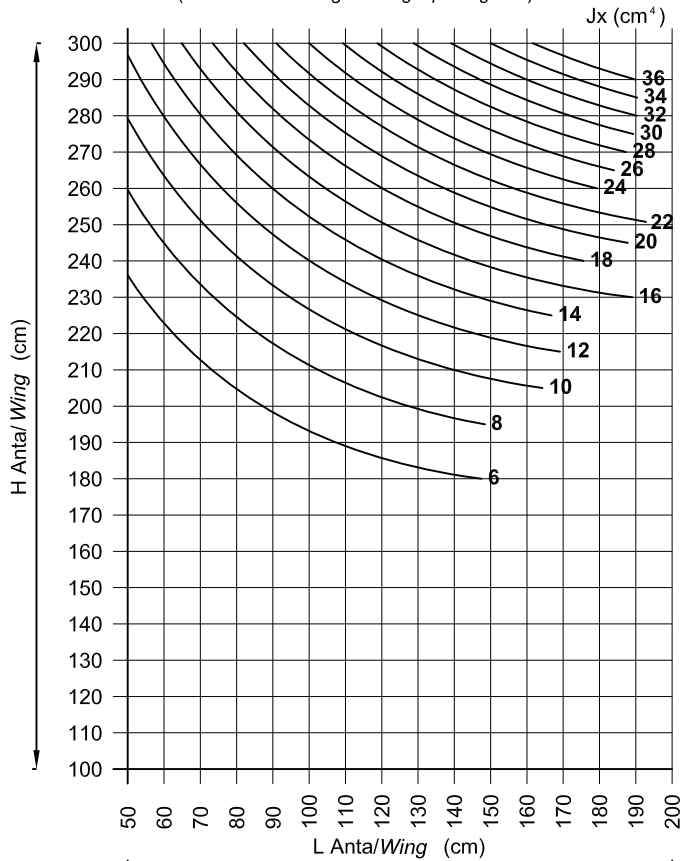

CARICO DEL VENTO/ WIND LOAD : q= 50 Kg/m²
 f max H/300 (Vetro isolante / insulating glass)

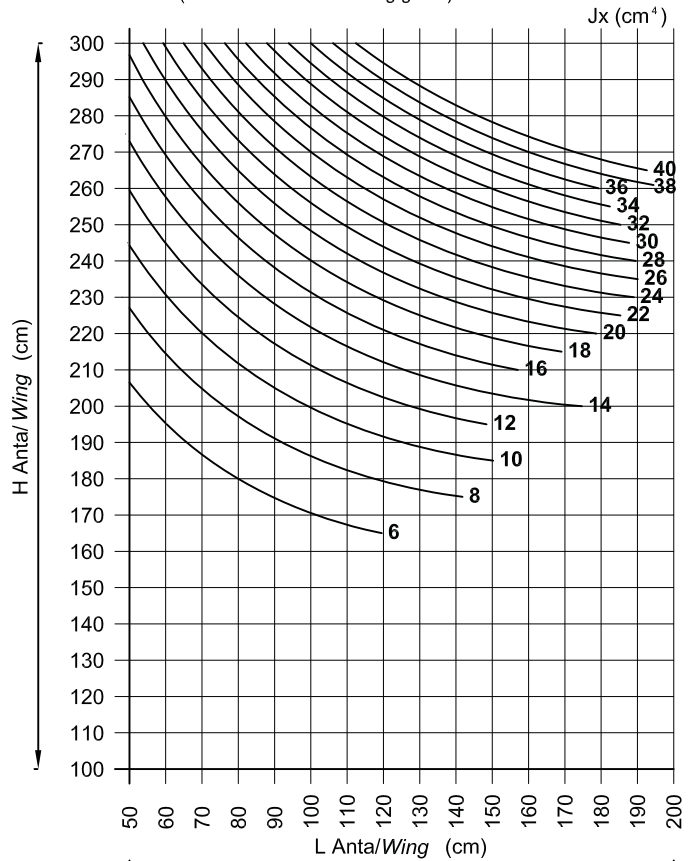

CARICO DEL VENTO/ WIND LOAD : $q=60 \text{ Kg/m}^2$
 f max H/200 (Vetro in lastra singola/ Single pane glass)

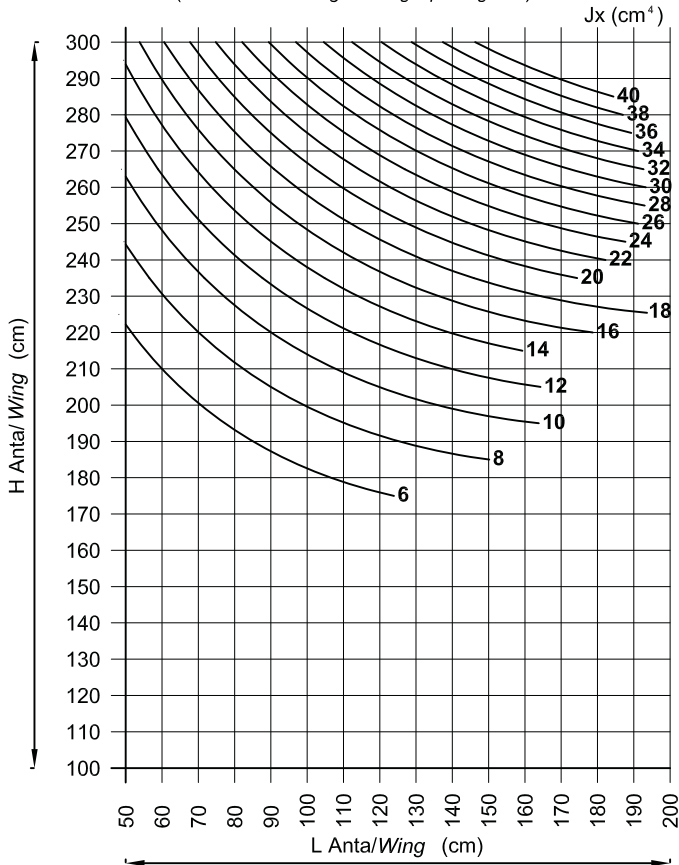

CARICO DEL VENTO/ WIND LOAD : $q=60 \text{ Kg/m}^2$
 f max H/300 (Vetro isolante / insulating glass)

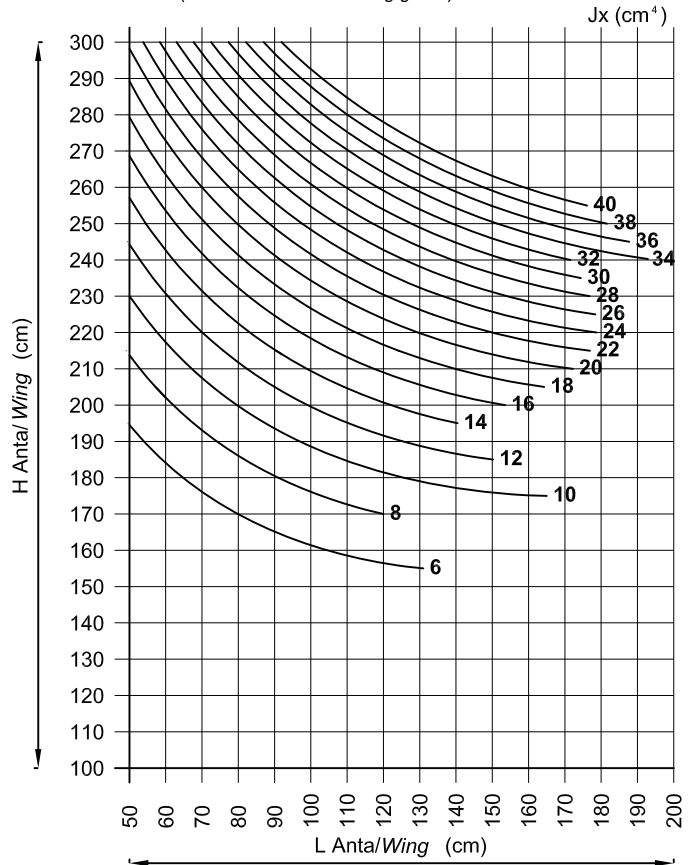

CARICO DEL VENTO/ WIND LOAD : $q=80 \text{ Kg/m}^2$
 f max H/200 (Vetro in lastra singola/ Single pane glass)

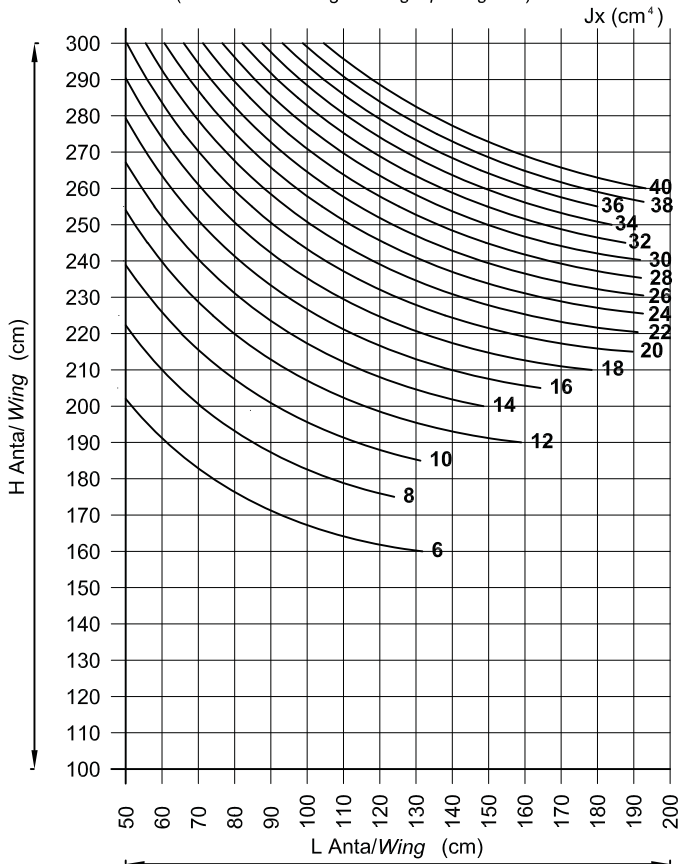

CARICO DEL VENTO/ WIND LOAD : $q=80 \text{ Kg/m}^2$
 f max H/300 (Vetro isolante / insulating glass)

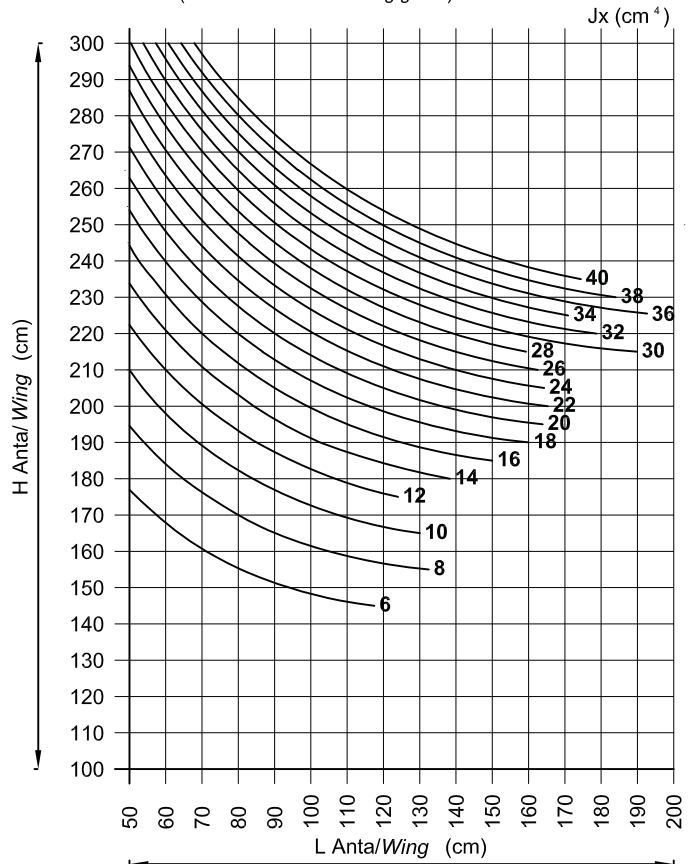

CARICO DEL VENTO/ WIND LOAD : $q = 100 \text{ Kg/m}^2$
 f max H/200 (Vetro in lastra singola/ Single pane glass)

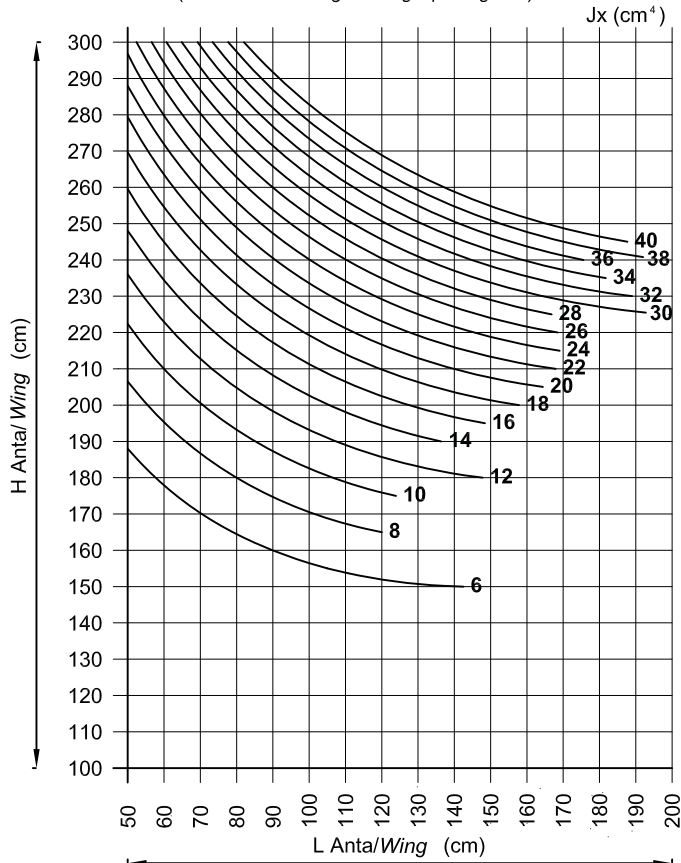

CARICO DEL VENTO/ WIND LOAD : $q = 100 \text{ Kg/m}^2$
 f max H/300 (Vetro isolante / Insulating glass)

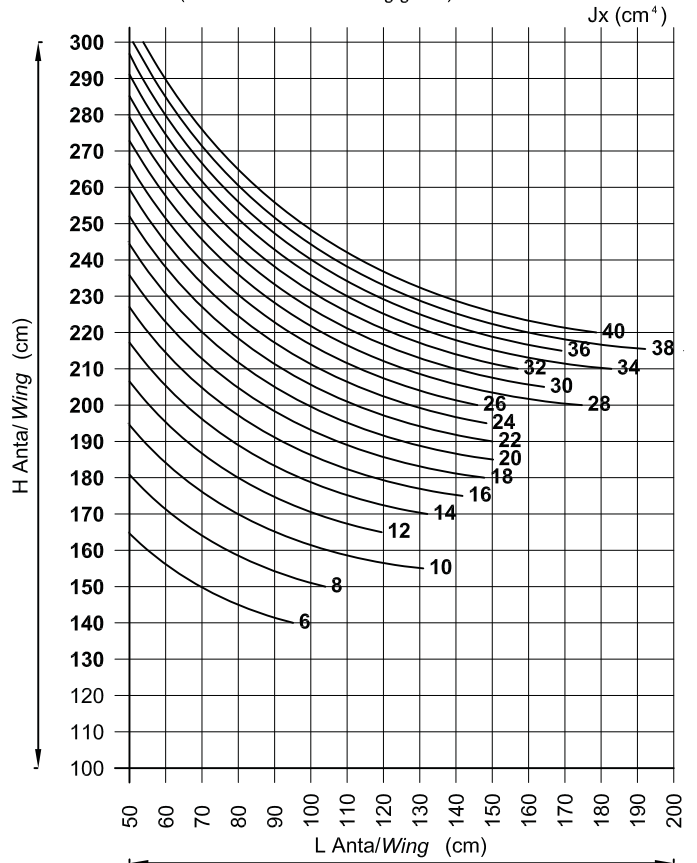

CARICO DEL VENTO/ WIND LOAD : $q = 120 \text{ Kg/m}^2$
 f max H/200 (Vetro in lastra singola/ Single pane glass)

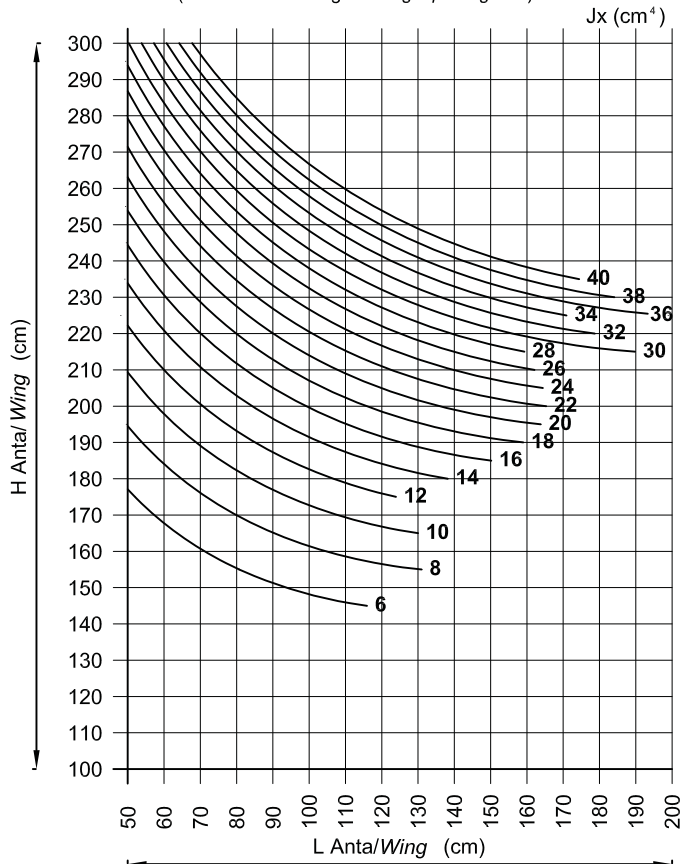

CARICO DEL VENTO/ WIND LOAD : $q = 120 \text{ Kg/m}^2$
 f max H/300 (Vetro isolante / Insulating glass)

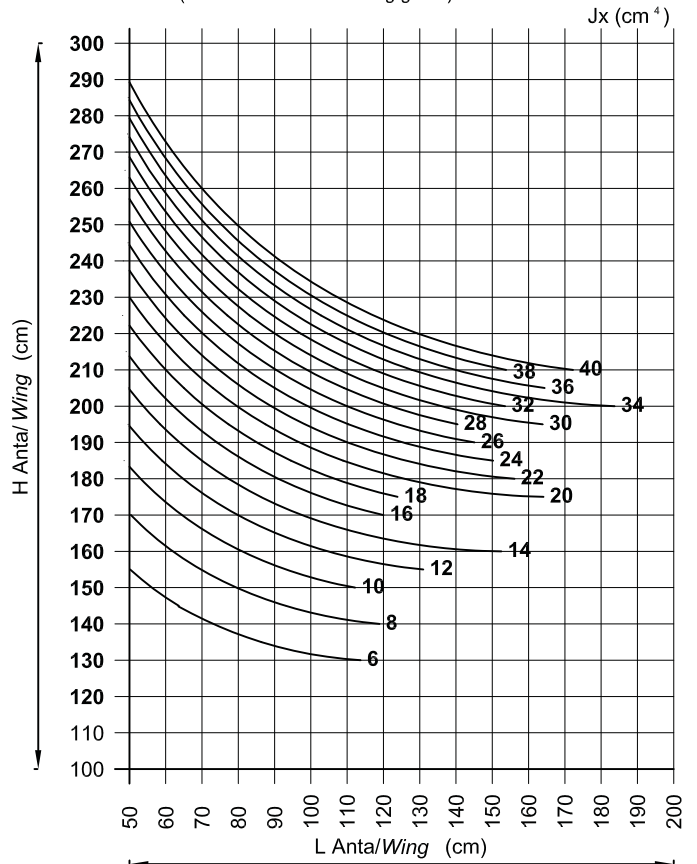

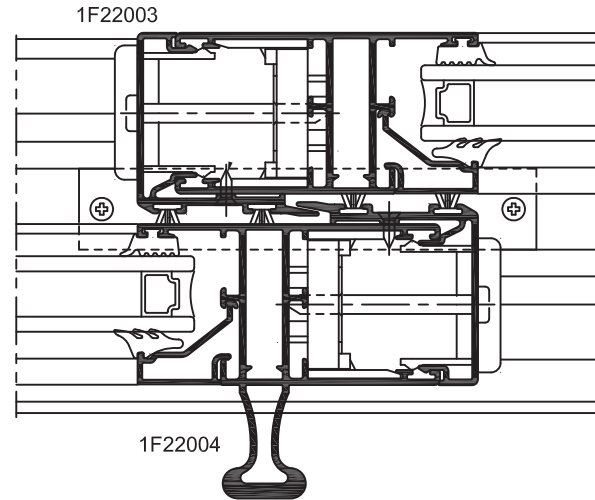
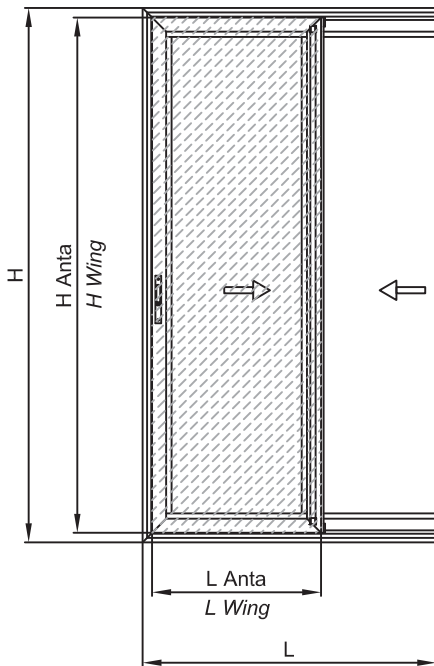

NOTE TECNICHE

- Peso Max Kg. 100 per anta
- Dimensioni La Max 1200 mm
- Dimensioni Ha Max 2120 mm
- Spessore vetro Max 16 mm
(Con La x Ha Max 1200x2120)

N.B.: Lo spessore del vetro si riferisce allo spessore del materiale senza la camera d'aria.

TECHNICAL DETAILS

- Maximum wing weight 100 Kg.
- Dimensions La Max 1200 mm
- Dimensions Ha Max 2120 mm
- Maximum glass thickness 16 mm
(With La x Ha Max 1200x2120)

N.B.: The glass thickness refers to the material thickness without air chamber.

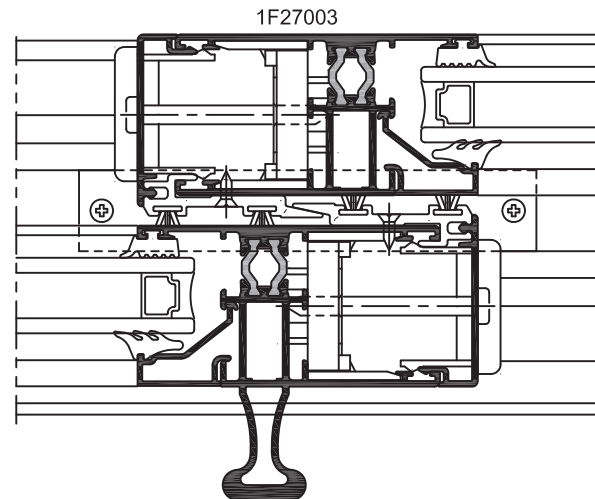
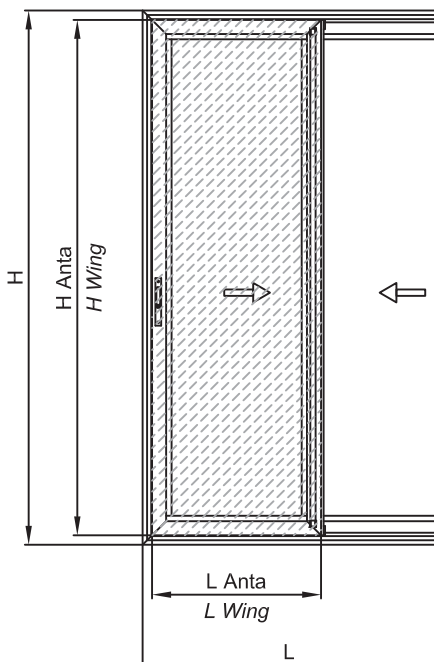

NOTE TECNICHE

- Peso Max Kg. 100 per anta
- Con kit carrelli regolabili art. A.0400.VA e binario acciaio inox art. B.0300.V1 portata 200 Kg
- Dimensioni La Max 1100 mm
- Dimensioni Ha Max 2020 mm
- Spessore vetro Max 20 mm
(Con La x Ha Max 1100x2020)

N.B.: Lo spessore del vetro si riferisce allo spessore del materiale senza la camera d'aria.

TECHNICAL DETAILS

- Maximum wing weight 100 Kg.
- Using roller kit A.0400.VA and rail code B.0300.V1 maximum wing weight 200 Kg
- Dimensions La Max 1100 mm
- Dimensions Ha Max 2020 mm
- Maximum glass thickness 20 mm
(With La x Ha Max 1100x2020)

N.B.: The glass thickness refers to the material thickness without air chamber.

Gli accessori originali, progettati appositamente e specifici del Sistema TEKNOWINDOW, sono gli unici collaudati e garantiscono nel tempo la qualità del prodotto finale.

Only the original accessories in the TEKNOWINDOW System guarantee lasting quality of products

AVVERTENZA **NOTE**

Per gli articoli indicati con ^(XXX) è possibile scegliere tra diversi produttori, tali articoli sono comunque forniti da Sapa. Le combinazioni possibili sono le seguenti:

(BP) - Prodotte da BMP e PRODUCTA.

Per ordinare tali prodotti, è necessario inserire al termine del codice i seguenti numeri:

01 - Per BMP

03 - Per PRODUCTA

Esempio: Art. G.0004.EN^(BP) La scelta può essere fatta tra BMP (ordinando il codice G.0004.EN.01) e PRODUCTA (codice G.0004.EN.03).

For the articles indicating^(XXX) there is the possibility to choose between different manufacturers although the goods will be supplied by Sapa. Here following the different combinations:

(BP) - Produced by BMP and PRODUCTA.

To order the articles you will need to indicate following numbers at the end of the code:

01 - For manufacturer BMP

03 - For manufacturer PRODUCTA

Example: Article G.0004.EN^(BP) the choice may be between BMP (ordering art. G.0004.EN.01) and PRODUCTA (ordering art. G.0004.EN.03).

AVVERTENZA **NOTE**

I prodotti descritti con il suffisso **.XX**, potranno essere forniti nelle finiture sotto indicate, sostituendo in sede di ordinazione l'indicazione **.XX** con i codici qui elencati:

00 = Grezzo

01 = Nero su materiali plastici

02 = Ossidato argento

06 = Ossidato bronzo

15 = Elettro 5

19 = Ossidato nero

37 = Verniciato argento

39 = Verniciato elettro 5

41 = Verniciato bianco RAL 9010

43 = Verniciato avorio RAL 1013

50 = Verniciato nero RAL 9005

60 = Verniciato su commessa ***

*** Quantitativi e prezzi da concordare

Esempio:

La maniglia int./est. ad incasso art. 12203.xx, se ordinata come 12203.41 verrà fornita verniciata bianca RAL 9010.

*Products described with the suffix **.XX** can be supplied with the finished by replacing the **.XX** with the codes listed below when ordering:*

00 = Raw

01 = Black on plastics

02 = Anodized silver

06 = Anodized bronze

15 = Electro 5

19 = Anodized black

37 = Painted silver

39 = Painted electro 5

41 = Painted white RAL 9010

43 = Painted ivory RAL 1013

50 = Painted black RAL 9005

*60 = Painted to order ****

*** Quantities and prices to be agreed

For example:

Insert internal/external handle code 12203.xx, will be supplied painted white RAL 9010 if ordered as 12203.41

SQUADRETTE D'ANGOLO
CORNER JOINTS

Articolo Item	Immagine Picture	Descrizione Description
10001.00		Squadretta allineamento battuta <i>Corner joint for alignment rabbet</i>
10040.01		In zama <i>Zamac</i> WIN90STT WIN90S
		In nylon <i>Nylon</i> WIN90STT WIN90S
10008.00		Squadretta a cianfrinare <i>Corner joint to be crimped</i>
10011.00		9,8 x 20,3 mm WIN90STT WIN90S
10012.00		9,8 x 36,1 mm WIN90S
		9,8 x 44,1 mm WIN90S
A.2921.AA		Squadretta a cianfrinare <i>Corner joint to be crimped</i>
10009.00		16,8 x 7 mm WIN90STT
10014.00		16,8 x 20,3 mm WIN90STT
		16,8 x 44,1 mm WIN90S
10026.00		Squadretta ad avvitare <i>Corner joint to be screwed</i>
10029.00		9,8 x 20,3 mm WIN90STT
10030.00		9,8 x 36,1 mm WIN90S
		9,8 x 44,1 mm WIN90S
10027.00		Squadretta ad avvitare <i>Corner joint to be screwed</i>
10032.00		16,8 x 20,3 mm WIN90STT
		16,8 x 44,1 mm WIN90STT

ELEMENTI DI FISSAGGIO
FIXING ELEMENTS

10401.00		Basetta in alluminio per regolo mobile <i>Aluminium plate for adjustable fixing</i>
		WIN90STT WIN90S
10402.01		Basetta in nylon per regolo mobile <i>Nylon plate for adjustable fixing</i>
		WIN90STT WIN90S
10403.00		Basetta rettangolare in alluminio per regolo mobile <i>Rectangular aluminium plate for adjustable fixing</i>
		WIN90STT WIN90S
10410.00		Grano per regolo mobile <i>Dowel for adjustable fixing</i>
		16,5 mm WIN90STT WIN90S
10411.00		23 mm WIN90STT WIN90S
10425.00		Molla aggancio coprifili <i>Edge cover coupling spring</i>
		WIN90STT WIN90S

TAPPI PLUGS

Articolo Item	Immagine Picture	Descrizione Description
10519.01		Tappo coprivite per vite da 4,8 mm <i>Cover plug for 4,8 mm screw</i>
		WIN90STT WIN90S
10535.01		Tappo copriforo Ø 12 mm <i>Hole plug Ø mm 12</i>
		WIN90STT WIN90S
10510.01		Base spessore 5 mm per tassello regolazione vetro <i>Glass registration dolly block 5 mm</i>
		WIN90STT WIN90S
10511.01		Spessore regolazione vetro <i>Glass registration spacer</i>
		2 mm WIN90STT WIN90S
10512.01		3 mm WIN90STT WIN90S
10513.01		4 mm WIN90STT WIN90S

SCARICHI ACQUA
WATER DRAINAGES

10501.01		Cappetta scarico acqua <i>Water drain cover</i>
		WIN90STT WIN90S
10505.01		Tappi raccoglicondensa (coppia) <i>Codensation drip plugs (pair)</i>
		WIN90STT WIN90S

SCARICHI ACQUA
WATER DRAINAGES

10545.xx		Angolo stampato per fermavetri arrotondati <i>Moulded for snap-on rounded glass beading</i>
		WIN90STT WIN90S
F.9000.01		Aggancio fermavetri arrotondati <i>Rounded glass beading coupling</i>
		WIN90STT WIN90S
A.0202.BA		Angolo stampato per fermavetri arrotondati su anta 1F27015 <i>Moulded for snap-on rounded glass beading for profile 1F27015</i>
		WIN90STT
A.9931.TN		Aggancio fermavetri arrotondati per anta 1F27015 <i>Rounded glass beading coupling for profile 1F27015</i>
		WIN90STT

ACCESSORI PER SCORREVOLI
SLIDING UNIT ACCESSORIES

12001.00		Kit 4 carrelli registrabili <i>4 adjustable double roller kit</i>
		WIN90STT WIN90S
12005.00		Supporto per anta fissa per profilati tipo 1F27001 <i>Fixed wing support for profile type 1F27001</i>
		WIN90STT WIN90S

ACCESSORI PER SCORREVOLI
SLIDING UNIT ACCESSORIES













CHIUSURA MULTIPUNTO
MULTIPOINT CLOSING



Articolo Item	Immagine Picture	Descrizione Description
12010.00		Kit tappi centrali, laterali e squadrette di allineamento <i>Alignment corner joint, central and lateral plug kit</i>
		WIN90STT WIN90S
12020.01		Tappi per gocciolatoio e raccoglicondensa (coppia) <i>Drip channel and drip condensation plugs (pair)</i>
		WIN90STT WIN90S
12025.01		Fondino per montante centrale rinforzato <i>Base for reinforced mullion</i>
		WIN90STT WIN90S
12027.00		Piastrina antisollevamento 3 e 4 anta <i>3th and 4th door non-lifting plate</i>
		WIN90STT WIN90S
12031.01		Kit valvola scarico acqua <i>Water drain valve kit</i>
		WIN90STT WIN90S
12070.00		Kit di aggancio chiusura ad incasso <i>Recessed clip-on locking kit</i>
		65 x 10 mm WIN90STT WIN90S
12071.00		Blocchetti di fissaggio e maniglia e rinforzo aletta <i>Fixing and building blocks for locking on fin</i>
		WIN90STT WIN90S
12201.xx		Maniglia interna ad incasso <i>Inset internal handle for locking</i>
		WIN90STT WIN90S
12203.xx		Maniglia int./est. ad incasso <i>Inset internal/external handle for locking</i>
		WIN90STT WIN90S
12204.xx		Maniglia int./est. ad incasso con serratura <i>Inset internal/external handle with cylinder lock</i>
		WIN90STT WIN90S
12208.xx		Maniglia laterale di trascinamento in alluminio <i>Aluminium lateral drag handle</i>
		WIN90STT WIN90S
A.2200.QN		Vaschetta drenaggio acqua <i>Water drainage tank</i>
		WIN90STT WIN90S
B.0300.V1		Binario in acciaio inox, compreso profilato adattatore in alluminio ossidato argento. Lunghezza 3m da abbinarsi a A.0400.VA <i>Stainless steel rail, including aluminium profile adapter silver anodized. Length 3 meter to combined with A.0400.VA</i>
		WIN90STT
A.0400.VA		Kit 4 carrelli regolabili, portata 200 Kg da abbinarsi a B.0300.V1 <i>4 adjustable roller kit, carrying capacity 200 Kg to combined with B.0300.V1</i>
		WIN90STT

Articolo Item	Immagine Picture	Descrizione Description
A.5101.VA		Ferramenta base universale <i>Universal base fitting</i>
		WIN90STT WIN90S
A.5102.VA		Elemento quarta chiusura <i>Element fourth closing</i>
		WIN90STT WIN90S
A.5106.VA		Kit accessori per chiusura con cremone <i>Kit accessories for cremone locking</i>
		WIN90STT WIN90S
A.5107.VA		KIT accessori per chiusura con paletto Europa, meccanismo bi-direzionale, doppia maniglia con chiave <i>Kit accessories for locking with Europe pole, double-way mechanism, double handle with key</i>
		WIN90STT WIN90S
A.5108.VA		Paletto Europa senza chiave <i>Europe pole without key</i>
		WIN90STT WIN90S
A.5109.VA		Paletto Europa con chiave <i>Europe pole with key</i>
		WIN90STT WIN90S
A.5109.VA		Paletto Europa con chiave <i>Europe pole with key</i>
		WIN90STT WIN90S
A.5110.VA		Cassa manico Opera Vip senza chiave <i>Cover Opera Vip without key</i>
		WIN90STT WIN90S
A.5111.VA		Cassa manico Opera Vip con chiave <i>Cover Opera Vip with key</i>
		WIN90STT WIN90S
A.5113.VA		Doppia maniglia interna-esterna con chiave <i>Double handle internal-external with key</i>
		WIN90STT WIN90S
A.5114.VA		Meccanismo bi-direzionale per martellina <i>Double-way mechanism internal</i>
		WIN90STT WIN90S

GUARNIZIONI
WEATHERSTRIPS

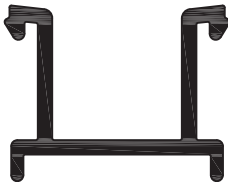

GUARNIZIONI POLIAMMIDE
POLYAMIDE WEATHERSTRIPS

Articolo Item	Immagine Picture	Descrizione Description
10821.01		Guarnizione di battuta in EPDM <i>EPDM weatherstrip of rabbet</i> WIN90STT WIN90S
10823.01		Guarnizione di battuta con piedino rigido in PVC <i>Weatherstrip of rabbet with PVC rigid foot</i> WIN90STT WIN90S
10841.01		Guarnizione vetro lato esterno in EPDM spessore 3 mm <i>EPDM weatherstrip thickness mm 3 for external glazing</i> WIN90STT WIN90S
10851.01		Guarnizione vetro lato esterno in EPDM spessore 5 mm <i>EPDM weatherstrip thickness mm 5 for external glazing</i> WIN90STT WIN90S
10852.01		Guarnizione vetro lato esterno in EPDM spessore 8 mm <i>EPDM weatherstrip thickness mm 8 for external glazing</i> WIN90STT WIN90S
G.0004.EN ^(BP)		Guarnizione vetro lato interno in EPDM spessore 3 mm <i>EPDM weatherstrip thickness mm 3 for internal glazing</i> WIN90STT WIN90S
G.0005.EN ^(BP)		Guarnizione vetro lato interno in EPDM spessore 4 mm <i>EPDM weatherstrip thickness mm 4 for internal glazing</i> WIN90STT WIN90S
10861.01		Guarnizione vetro lato interno sp. 5 mm <i>Weatherstrip internal glazing thickness 5 mm</i> EPDM WIN90STT WIN90S
10862.01		PVC WIN90STT WIN90S
10871.01		Guarnizione vetro lato interno sp. 6 mm <i>Weatherstrip internal glazing thickness 6 mm</i> EPDM WIN90STT WIN90S
10872.01		PVC WIN90STT WIN90S
G.0000.HA		Guarnizione a spazzolino <i>Protective fiber</i> WIN90STT WIN90S

Articolo Item	Immagine Picture	Descrizione Description
G.0301.QN		Coprigiunto telaio Win 90sTT <i>Joint covering frame Win 90sTT</i> WIN90STT WIN90S
G.0302.QN		Incontro centrale due ante Win 90sTT <i>Two wings striker plate Win 90sTT</i> WIN90STT

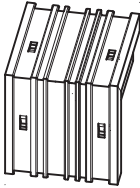

SCHEMA DI IMPIEGO: SQUADRETTE, CAVALLOTTI, ALLINEAMENTO TRAVERSI
 USE SCHEME: CORNER JOINTS, "T" JOINTS, TRANSOM ALIGNMENT

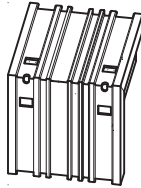
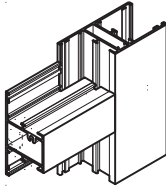
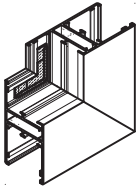
WIN 90s
SYSTEM

Profilato Section	Esterna a cianfrinare External crimping	Interna a cianfrinare Internal crimping	Avvitare Screwing	Cavallotto Allineamento trasversi "T" joint -Transom alignment	Allineamento su aletta di battuta Alignment on rabbet
					
1F22001	10011.00	10011.00	10029.00 (*)		
1F22002	10012.00	10012.00	10030.00 (*)		
1F22003		10011.00	10029.00		10040.01 o/or 10001.00
1F22004		10011.00	10029.00		10040.01 o/or 10001.00
1F22006	10008.00 (**)	10014.00	10032.00		10040.01 o/or 10001.00
1F22010	10011.00	10011.00	10029.00 (*)		
1F22011	10012.00	10012.00	10030.00 (*)		
1F22012		10011.00	10029.00		10040.01 o/or 10001.00
1F22013	10011.00	10011.00	10029.00 (*)		
1F22014	10012.00	10012.00	10030.00 (*)		

SCHEMA DI IMPIEGO: SQUADRETTE, CAVALLOTTI, ALLINEAMENTO TRAVERSI
 USE SCHEME: CORNER JOINTS, "T" JOINTS, TRANSOM ALIGNMENT

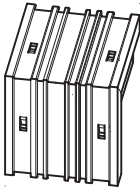
WIN 90s^{TT}
SYSTEM

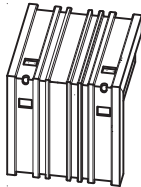
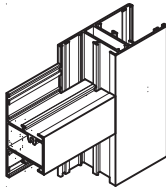
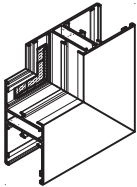



Profilato Section	Esterna a cianfrinare External crimping	Interna a cianfrinare Internal crimping	Avvitare Screwing	Cavallotto Allineamento trasversi "T" joint -Transom alignment	Allineamento su aletta di battuta Alignment on rabbet
					
1F27001	10008.00	10008.00	10026.00 (*)		
1F27002	10008.00	10008.00	10026.00 (*)		
1F27003		10008.00	10026.00		10040.01 o/or 10001.00
1F27004		10008.00	10026.00		10040.01 o/or 10001.00
1F27006	10008.00 (**)	10009.00	10027.00		10040.01 o/or 10001.00
1F27008	A.2921.AA	10009.00	10027.00		
1F27009			10026.00		10040.01 o/or 10001.00
1F27010	10008.00	10008.00	10026.00 (*)		10040.01 o/or 10001.00
1F27011	10008.00	10008.00	10026.00 (*)		
1F27012	10008.00	10008.00	10026.00 (*)		10040.01 o/or 10001.00
1F27013	10008.00	10008.00	10026.00 (*)		10040.01 o/or 10001.00
1F27014	10008.00	10008.00	10026.00 (*)		
1F27015		10008.00	10026.00		10040.01 o/or 10001.00



















(**) La squadretta esterna non puo essere cianfrinata, deve essere incollata

(**) External corner joint can not be crimped, must be glued.

(*) Va inserita anche nel tubolare esterno

(*) To be insert also on external tubular.

Articolo Item	Guarnizioni esterne External weatherstrips	Sezione Section	Articolo Item	Guarnizioni interne Internal weatherstrips	Sezione Section
10841.01	A = 3 mm		10861.01 10862.01	C = 5 mm	
10851.01	B = 5 mm		10871.01 10872.01	D = 6 mm	

Spessore vetri Glass thickness	Guarnizioni Weatherstrips	Dimensione fermavetri Glass beading size	Sezione fermavetri Glass beading section
WIN 90s ^{TT} SYSTEM	WIN 90s ^{TT} SYSTEM		
4	B+D	24,5 mm	 1F14007
5	B+C		 1F14015
6	A+D		 1F14053
7	A+C		
8	B+D	20,5 mm	 1F14006
9	B+C		 1F14014
10	A+D		 1F14052
11	A+C		
10	B+D	19 mm	 1F14068
11	B+C		
12	A+D		
13	A+C		
12	B+D	16,5 mm	 1F14005
13	B+C		 1F14013
14	A+D		 1F14051
15	A+C		
15	B+D	14,5 mm	 1F14055
16	B+C		 1F14049
17	A+D		
18	A+C		
16	B+D	12,5 mm	 1F14004
17	B+C		 1F14012
18	A+D		
19	A+C		
18	B+D	10,5 mm	 1F14062
19	B+C		
20	A+D		
21	A+C		
20	B+D	8,5 mm	 1F14003
21	B+C		 1F14065
22	A+D		
23	A+C		
24	B+D	4,5 mm	 1F14044
25	B+C		
26	A+D		
27	A+C		
26	B+D	2,5 mm	 1F14002
27	B+C		
28	A+D		
29	A+C		

N.B.: Le combinazioni sopra indicate sono state ottenute considerando le quote teoriche. Si consiglia sempre di verificare le tolleranze per applicare vetri, fermavetri e guarnizioni ottimali
The above combinations are based on theoretical dimensions. It is always best to check tolerances to apply correct glass, glass beadings and weatherstrips.

Sezione fermavetri Glass beading section		Dimensione Size
(F)	(G)	
		28,5 mm
1F14016	1F14054	
		24,5 mm
1F14015	1F14053	
		20,5 mm
1F14014	1F14052	
		16,5 mm
1F14013	1F14051	
		14,5 mm
1F14055	1F14049	

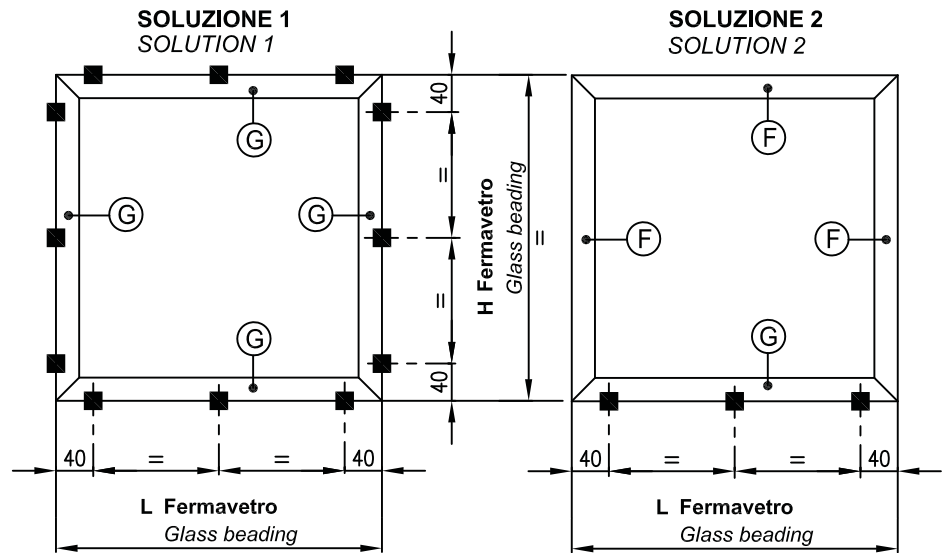

■ = Art. F.9000.01

Per L/H ≤ 1000 mm

Per L/H > 1000 mm ≤ 1500 mm

Per L/H > 1500 mm

n. 3 pz.

n. 4 pz.

n. 5 pz.

(F) = Fermavetro arrotondato a scatto

Rounded glass beading with snap mechanism





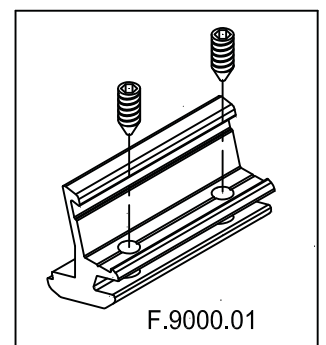
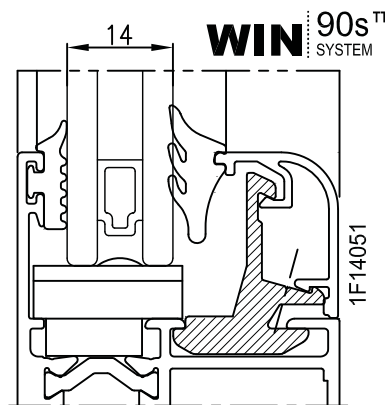
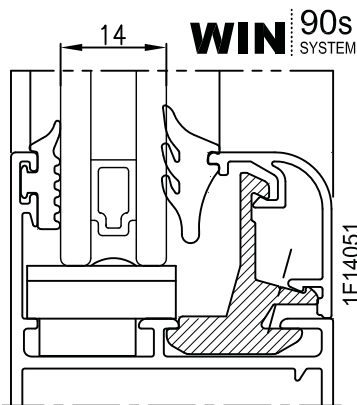

(G) = Fermavetro arrotondato con accessorio F.9000.01

















Rounded glass beading with accessory F.9000.01



INSERIMENTO GUARNIZIONI, VETRI E FERMAVETRI ANTA "1F27015"
WEATHERSTRIPS, GLASS AND GLASS BEADINGS INSERT WING "1F27015"

WIN 90s^{TT}
 SYSTEM

Articolo Item	Guarnizioni esterne External weatherstrips	Sezione Section	Articolo Item	Guarnizioni interne Internal weatherstrips	Sezione Section
10841.01	A = 3 mm		10861.01 10862.01	C = 5 mm	
10851.01	B = 5 mm		10871.01 10872.01	D = 6 mm	
WIN 90s ^{TT} SYSTEM			G.0004.EN	E = 3 mm	
			G.0005.EN	F = 4 mm	

Spessore vetri Glass thickness	Guarnizioni Weatherstrips	Dimensione fermavetri Glass beading size	Sezione Fermavetri Glass beading section			
4	A+E	26 mm				
4	B+F					
5	A+C					
5	B+E					
6	A+F					
6	A+E					
7	A+E					
7	B+D	21 mm				
8	B+C					
9	B+F					
9	A+D					
10	B+E					
10	A+C					
11	A+F					
12	A+E					
10	B+D	18 mm				
11	B+C					
12	B+F					
12	A+B					
13	B+E					
13	A+C					
14	A+F					
15	A+E					
12	B+D	16 mm				
13	B+C					
14	B+F					
14	A+D					
15	B+E					
15	A+C					
16	A+F					
17	A+E					
17	B+D	11 mm				
18	B+C					
19	B+F					
19	A+D					
20	B+E					
20	A+C					
21	A+F					
22	A+E					
25	B+D	3 mm				
26	B+C					
27	B+F					
27	A+D					
28	B+E					
28	A+C					
29	A+F					
30	A+E					

B+D	= 11
B+C	= 10
B+F	= 9
A+C / B+E	= 8
A+F	= 7
A+E	= 6

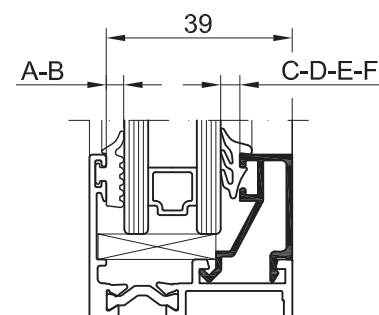











N.B.: Le combinazioni sopra indicate sono state ottenute considerando le quote teoriche. Si consiglia sempre di verificare le tolleranze per applicare vetri, fermavetri e guarnizioni ottimali

The above combinations are based on theoretical dimensions. It is always best to check tolerances to apply correct glass, glass beadings and weatherstrips.

POSIZIONAMENTO ACCESSORIO FERMAVETRO ARROTONDATO ANTA "1F27015"
ROUNDED GLASSES BEADING ACCESSORY POSITIONING WING "1F27015"

WIN 90s^{TT}
 SYSTEM

Sezione Fermavetri <i>Glass Beading Section</i>		Dimensione <i>Size</i>
ⓕ	ⓐ	
		26 mm
1A64053	1A64553	
		21 mm
1A64052	1A64552	
		18 mm
1A64246	1A64421	
		16 mm
1A64247	1A64556	
		11 mm
1A64248	1A64557	

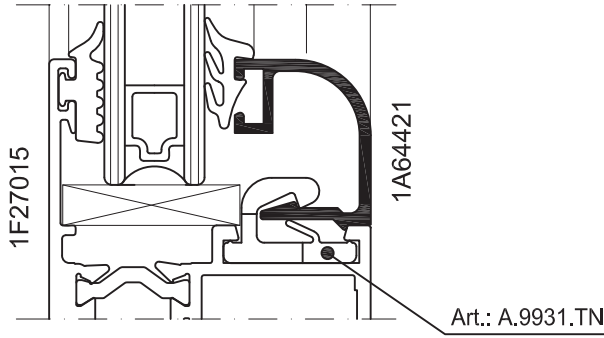
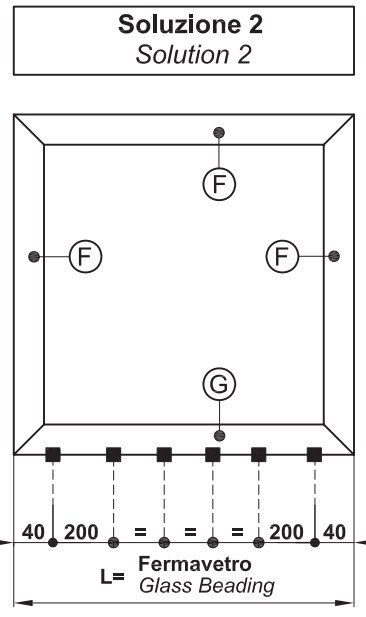
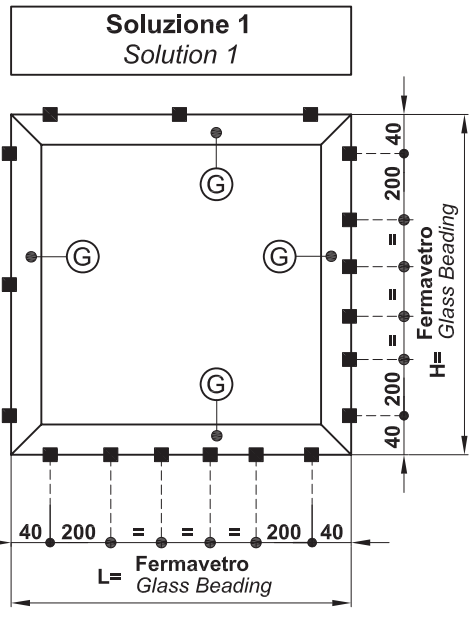







- ⓕ = Fermavetro arr. a scatto
Radiused glass beading snap
- ⓐ = Fermavetro arr. con accessorio A.9931.TN
Radiused glass beading with accessoire A.9931.TN
- = Art. A.9931.TN

INSERIMENTO GUARNIZIONI, VETRI AD INFILARE
WEATHERSTRIPS AND GLASS INSERTION

WIN 90s^{TT}
 SYSTEM

WIN 90s
 SYSTEM



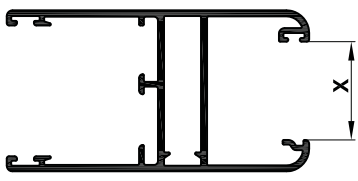
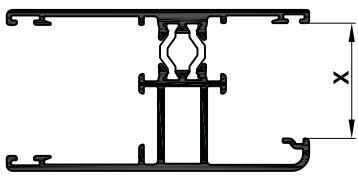

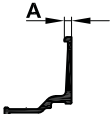
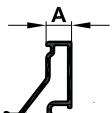
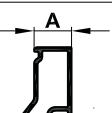
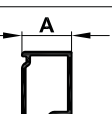
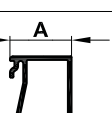
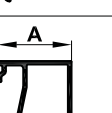
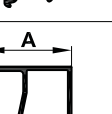
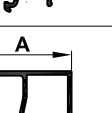
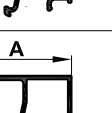
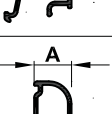
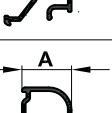
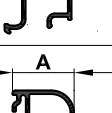
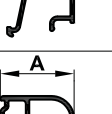

Articolo Item	Guarnizioni esterne External weatherstrips	Sezione Section	Articolo Item	Guarnizioni interne Internal weatherstrips	Sezione Section
10841.01	A = 3 mm		G.0004.EN	E = 3 mm	
10851.01	B = 5 mm		G.0005.EN	F = 4 mm	
			10861.01 10862.01	C = 5 mm	
			10871.01 10872.01	D = 6 mm	

Spessore vetri Glass thickness		Guarnizioni Weatherstrips	Dimensione Size	Sezione profilati Cross sections
WIN 90s SYSTEM	WIN 90s ^{TT} SYSTEM			
16	-	B+D	X = 26 mm	 1F22012
17	-	B+C		
18	-	B+F A+D		
19	-	B+E A+C		
20	-	A+F		
21	-	A+E		
-	20	B+D	X = 30 mm	 1F27009
-	21	B+C		
-	22	B+F A+D		
-	23	B+E A+C		
-	24	A+F		
-	25	A+E		

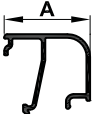
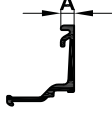



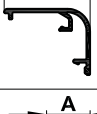
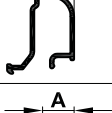
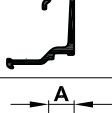
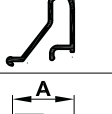
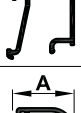
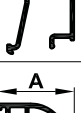
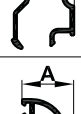



N.B.: Le combinazioni sopra indicate sono state ottenute considerando le quote teoriche. Si consiglia sempre di verificare le tolleranze per applicare vetri, fermavetri e guarnizioni ottimali

The above combinations are based on theoretical dimensions. It is always best to check tolerance to apply correct glass, glass beadings and weatherstrips.

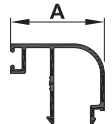
Profilato Section	Sezione Cross section 	A mm	Peso Weight Kg/m	Perimetro Perimeter mm	Superficie in vista Exposed surface m ² /m	Jx cm ⁴	Wx cm ³	Jy cm ⁴	Wy cm ³
1F14002		2,5	0,196	95	0,024	—	—	—	—
1F14003		8,5	0,236	146	0,030	—	—	—	—
1F14004		12,5	0,245	151	0,034	—	—	—	—
1F14005		16,5	0,253	156	0,038	—	—	—	—
1F14006		20,5	0,281	170	0,042	—	—	—	—
1F14007		24,5	0,297	181	0,046	—	—	—	—
1F14008		28,5	0,313	187	0,050	—	—	—	—
1F14009		32,5	0,330	195	0,054	—	—	—	—
1F14010		36,5	0,346	203	0,058	—	—	—	—
1F14012		12,5	0,235	145	0,032	—	—	—	—
1F14013		16,5	0,243	150	0,036	—	—	—	—
1F14014		20,5	0,272	165	0,040	—	—	—	—
1F14015		24,5	0,288	173	0,044	—	—	—	—

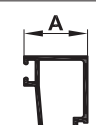

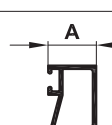
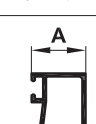

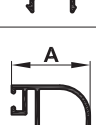
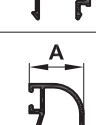
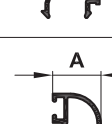
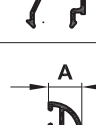
Profilato Section	Sezione Cross section 	A mm	Peso Weight Kg/m	Perimetro Perimeter mm	Superficie in vista Exposed surface m ² /m	Jx cm ⁴	Wx cm ³	Jy cm ⁴	Wy cm ³
1F14016		28,5	0,304	181	0,048	—	—	—	—
1F14044		4,5	0,222	108	0,026	—	—	—	—
1F14049		14,5	0,153	95	0,034	—	—	—	—
1F14051		16,5	0,165	103	0,036	—	—	—	—
1F14052		20,5	0,180	112	0,040	—	—	—	—
1F14053		24,5	0,202	119	0,044	—	—	—	—
1F14054		28,5	0,218	127	0,048	—	—	—	—
1F14055		14,5	0,240	148	0,034	—	—	—	—
1F14062		10,5	0,242	123	0,032	—	—	—	—
1F14065		8,5	0,226	140	0,028	—	—	—	—
1F14066		20,5	0,273	161	0,039	—	—	—	—
1F14068		19	0,259	159	0,039	—	—	—	—
1F14072		25,5	0,295	176	0,042	—	—	—	—
1F14073		17,5	0,251	149	0,034	—	—	—	—

ELENCO FERMAVETRI " PER ANTA 1F27015 "
LIST OF GLAZING BEADS " FOR WING 1F27015 "

Profilato Section	Sezione Cross section 	A mm	Peso Weight Kg/m	Perimetro Perimeter mm	Superficie in vista Exposed surface m ² /m	Jx cm ⁴	Wx cm ³	Jy cm ⁴	Wy cm ³
1A10032		26	0,311	194	0,048	—	—	—	—
1A10034		31	0,312	195	0,044	—	—	—	—
1A58948		26	0,315	198	0,048	—	—	—	—
1A58949		21	0,272	172	0,043	—	—	—	—
1A59847		11	0,252	159	0,033	—	—	—	—
1A59848		16	0,257	162	0,038	—	—	—	—
1A62167		18	0,262	165	0,040	—	—	—	—
1A64052		21	0,255	159	0,038	—	—	—	—
1A64053		26	0,296	185	0,043	—	—	—	—
1A64246		18	0,244	154	0,035	—	—	—	—
1A64247		16	0,240	151	0,033	—	—	—	—
1A64248		11	0,234	146	0,028	—	—	—	—

ELENCO FERMAVETRI " PER ANTA 1F27015 "
LIST OF GLAZING BEADS " FOR WING 1F27015 "

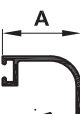
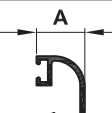
WIN 90s^{TT}
 SYSTEM

Profilato Section	Sezione Cross section 	A mm	Peso Weight Kg/m	Perimetro Perimeter mm	Superficie in vista Exposed surface m ² /m	Jx cm ⁴	Wx cm ³	Jy cm ⁴	Wy cm ³
1A64421		18	0,243	125	0,035	—	—	—	—
1A64552		21	0,256	131	0,038	—	—	—	—
1A64553		26	0,276	141	0,043	—	—	—	—
1A64556		16	0,236	121	0,033	—	—	—	—
1A64557		11	0,215	108	0,028	—	—	—	—
1A70796		3	0,181	94	0,025	—	—	—	—

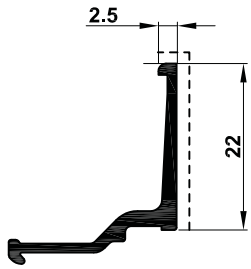

1F14002

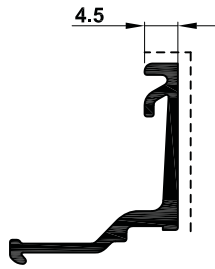

1F14044

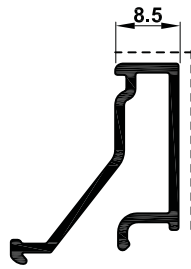

1F14003

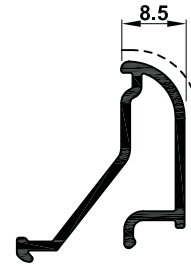

1F14065

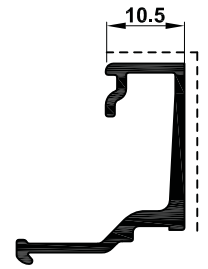

1F14062

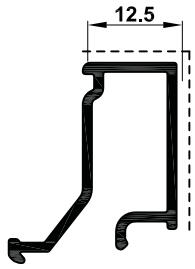

1F14004

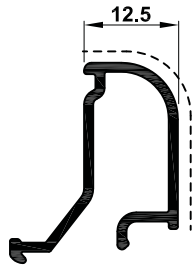

1F14012

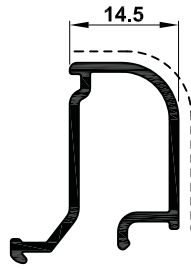

1F14055

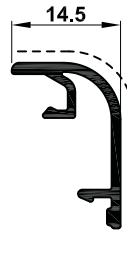

1F14049

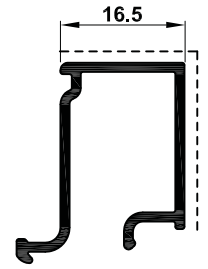

1F14005

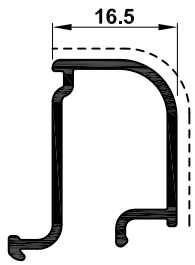

1F14013

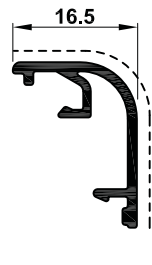

1F14051

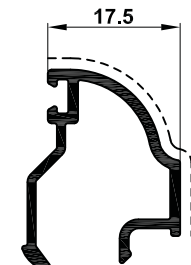

1F14073

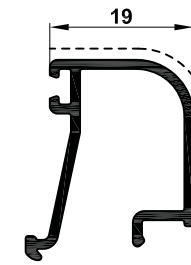

1F14068

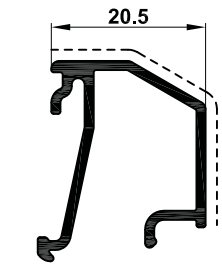

1F14066

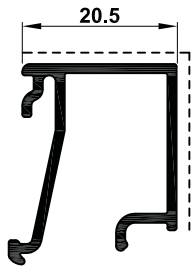

1F14006

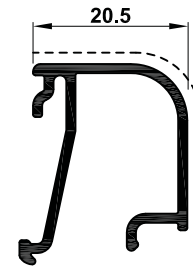

1F14014

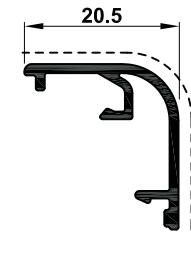

1F14052

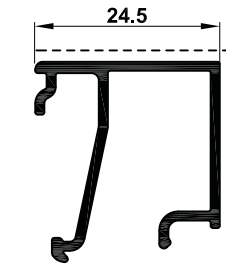

1F14007

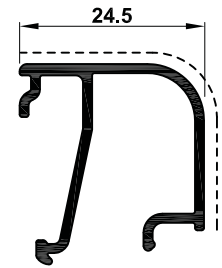

1F14015

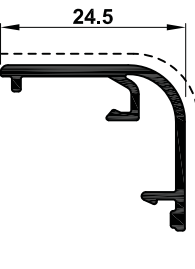

1F14053

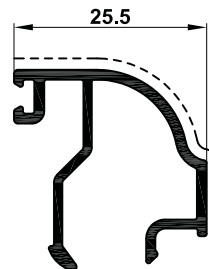

1F14072

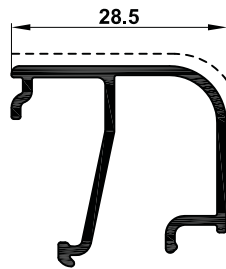

1F14016

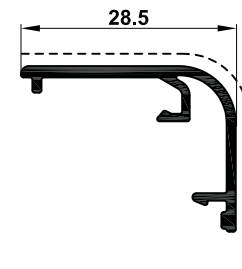

1F14054

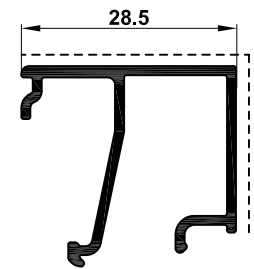

1F14008

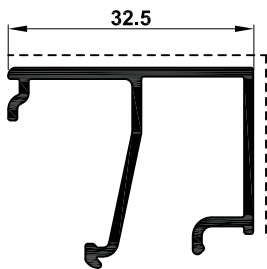

1F14009

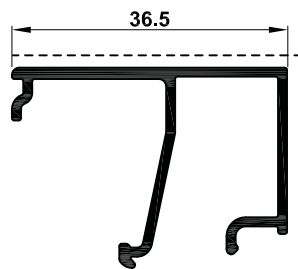

1F14010

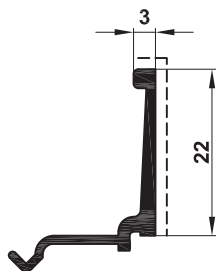

1A70796

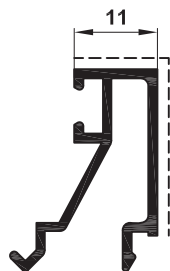

1A59847



1A64248



1A64557

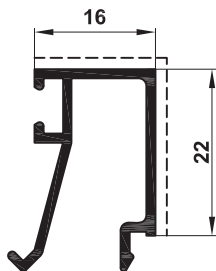

1A59848

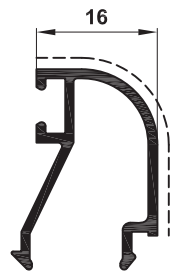

1A64247

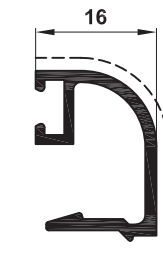

1A64556

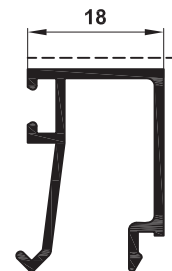

1A62167

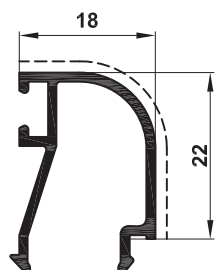

1A64246

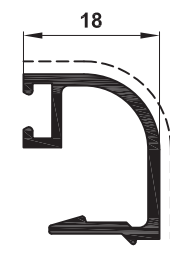

1A64421

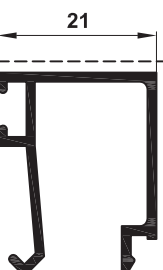

1A58949

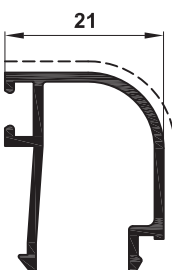

1A64052

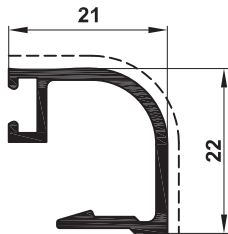

1A64552

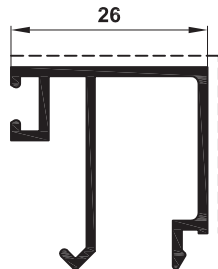

1A58948

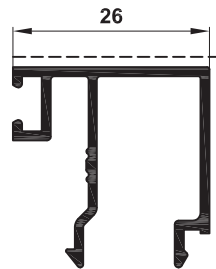

1A10032 (*)

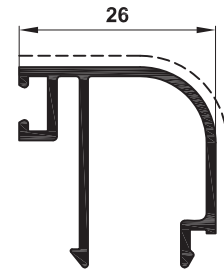

1A64053(*)

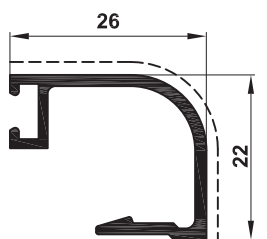

1A64553

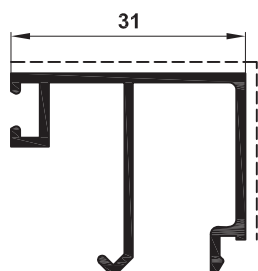

1A59849

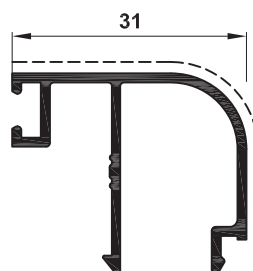

1A10034 (*)

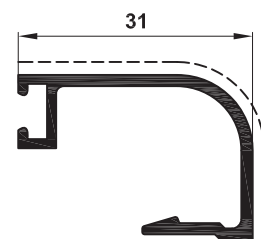

1A64554

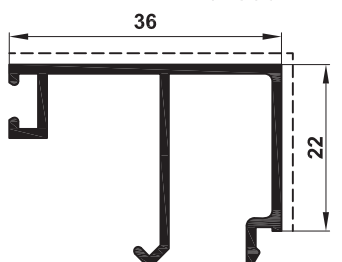

1A59850

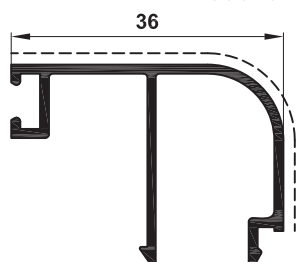

1A68137

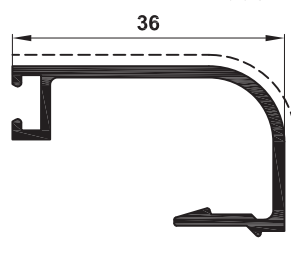











1A64555

(*) Lo scatto del fermavetro può avvenire anche con rotazione dall'interno verso l'esterno

(*) The locking of the glazing bead can also occur with rotation from the inside outwards

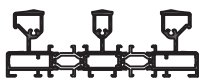
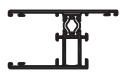
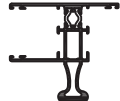

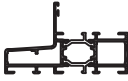

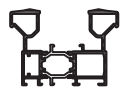
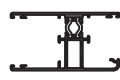
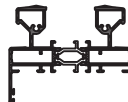



ELENCO PROFILATI
LIST OF SECTIONS

WIN 90s^{TT}
SYSTEM

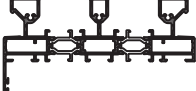
Profilato Section	Comp.ne Composition	Sezione Cross section 	Peso Weight Kg/m	Perimetro Perimeter mm	Superficie in vista Exposed surface m ² /m	Jx cm ⁴	Wx cm ²	Jy cm ⁴	Wy cm ³
1F24001			0,321	166	0,087	-	-	-	-
1F24003			0,278	143	0,055	-	-	-	-
1F24005			0,279	120	0,051	-	-	-	-
1F24006			0,150	45	0,010	-	-	-	-
1F27001	1F25001 A.0313.LN A.0313.LN 1F25001		2,254	539	0,176	17,85	6,67	63,66	14,15
1F27002	1F25001 A.0313.LN x 2 1F25006 A.0313.LN x 2 1F25001		3,389	799	0,191	25,17	9,34	221,21	31,49
1F27003	1F25005 A.0311.LN A.0311.LN 1F25002		1,302	446	0,150	13,10	5,57	15,16	3,74
1F27004	1F25005 A.0311.LN A.0311.LN 1F25003		1,821	520	0,224	40,95	10,15	16,47	3,97
1F27005	1F25007 A.0311.LN A.0311.LN 1F25008		1,344	353	0,123	10,68	4,21	12,09	2,98
1F27006	1F25009 A.0313.LN A.0313.LN 1F15005		1,605	452	0,117	40,62	8,58	6,89	1,90
1F27007	1F25010 A.0313.LN A.0313.LN 1F25010		0,872	270	0,046	7,01	2,95	0,99	0,77
1F27008	1F25013 A.0313.LN A.0313.LN 1F25012		1,959	449	0,170	20,87	7,43	41,72	10,48
1F27009	1F25005 A.0311.LN A.0311.LN 1F25011		1,420	502	0,179	14,93	6,89	19,96	4,70
1F27010	1F25014 A.0313.LN A.0313.LN 1F25001		2,360	597	0,201	22,43	5,47	70,89	15,04



ELENCO PROFILATI
LIST OF SECTIONS

WIN 90s^{TT}
SYSTEM

Profilato Section	Comp.ne Composition	Sezione Cross section 	Peso Weight Kg/m	Perimetro Perimeter mm	Superficie in vista Exposed surface m ² /m	Jx cm ⁴	Wx cm ²	Jy cm ⁴	Wy cm ³
1F27011	1F25025 A.0313.LN A.0313.LN 1F25025		1,914	470	0,154	15,50	6,08	43,95	11,04
1F27012	1F25024 A.0313.LN A.0313.LN 1F25025		2,022	529	0,180	20,39	4,69	48,37	11,57
1F27013	1F25014 A.0313.LN x 2 1F25006 A.0313.LN x 2 1F25001		3,495	856	0,216	25,17	9,34	221,21	31,49
1F27014	1F25035 A.0313.LN A.0313.LN 1F25035		2,148	573	0,156	15,48	5,77	61,15	13,59
1F27015	1F25005 A.0311.LN A.0311.LN 1F25036		1,294	455	0,148	13,02	5,51	15,10	3,71
1F27016	1F25007 A.0311.LN A.0311.LN 1F25039		1,327	340	0,123	10,47	4,10	11,88	2,93
1F27017	1F25009 A.0313.LN A.0313.LN 1F15004		1,711	506	0,142	9,92	2,60	47,17	9,40
900424			0,219	93	0,037	-	-	-	-

ELENCO BARRETTE IN POLIAMMIDE
LIST OF REINFORCED POLYAMIDE BARS

WIN 90s^{TT}
SYSTEM

Codice Code	Sezione Cross section	Peso Weight Kg/m
A.0311.LN		0,045
A.0313.LN		0,077

Scala 1:1
Scale 1:1



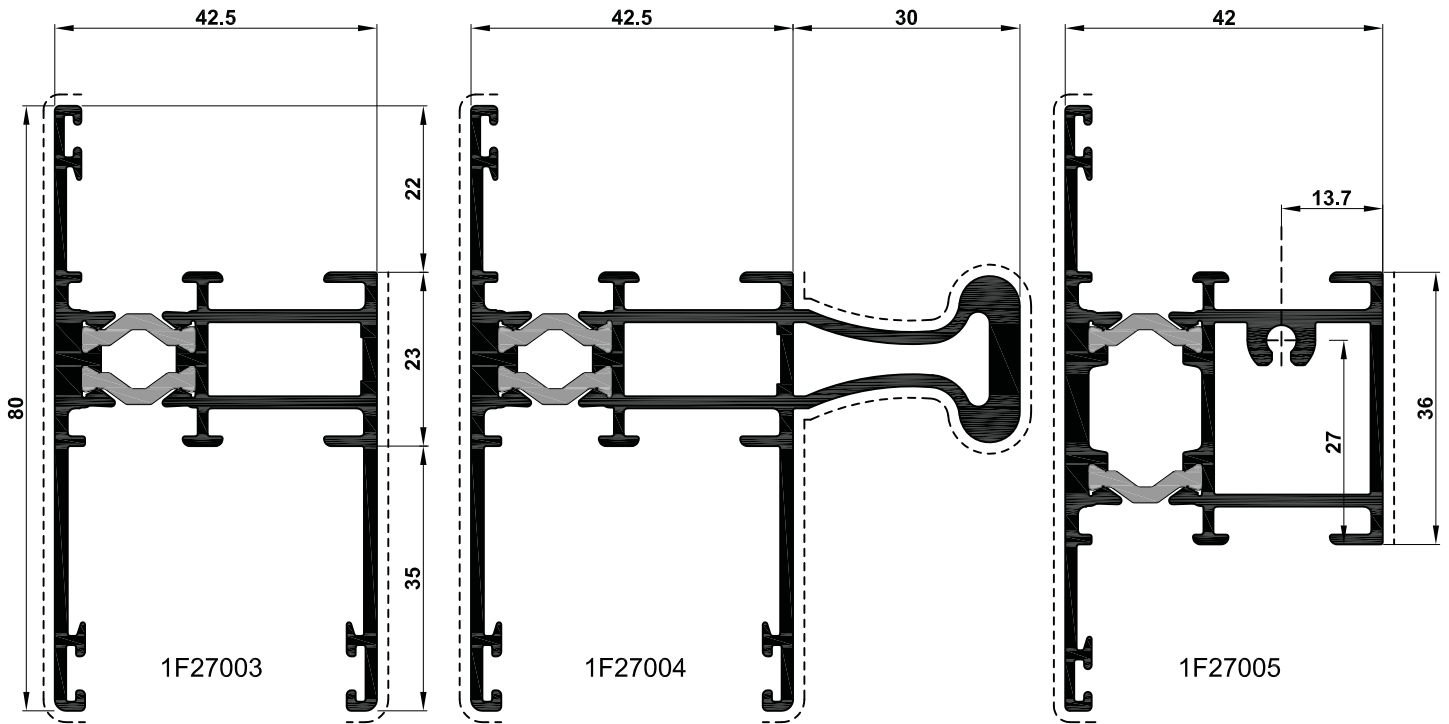

SOLUZIONE ANTA E TRAVERSO CON FERMAVETRO "ALFIL"
SOLUTIONS WING AND TRANSOM WITH GLASS BEADING "ALFIL"

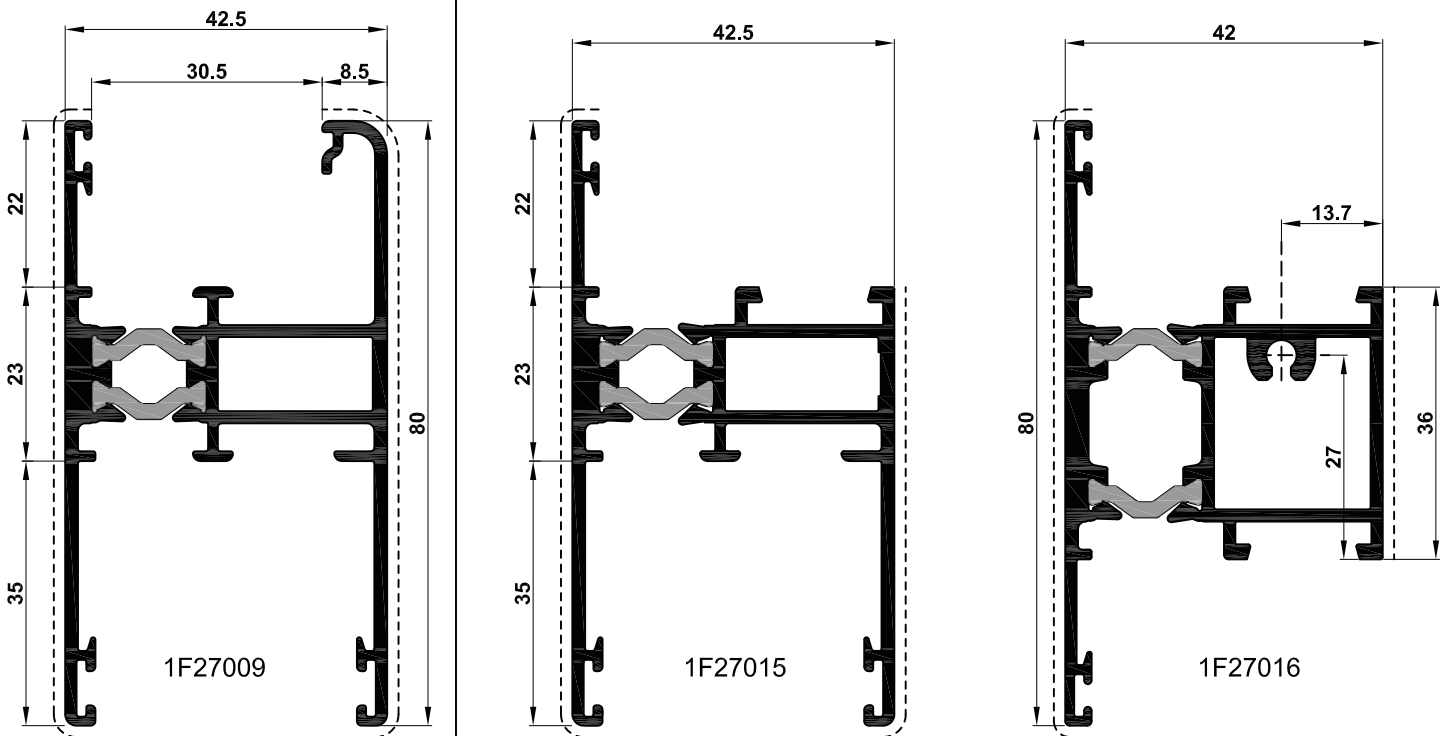

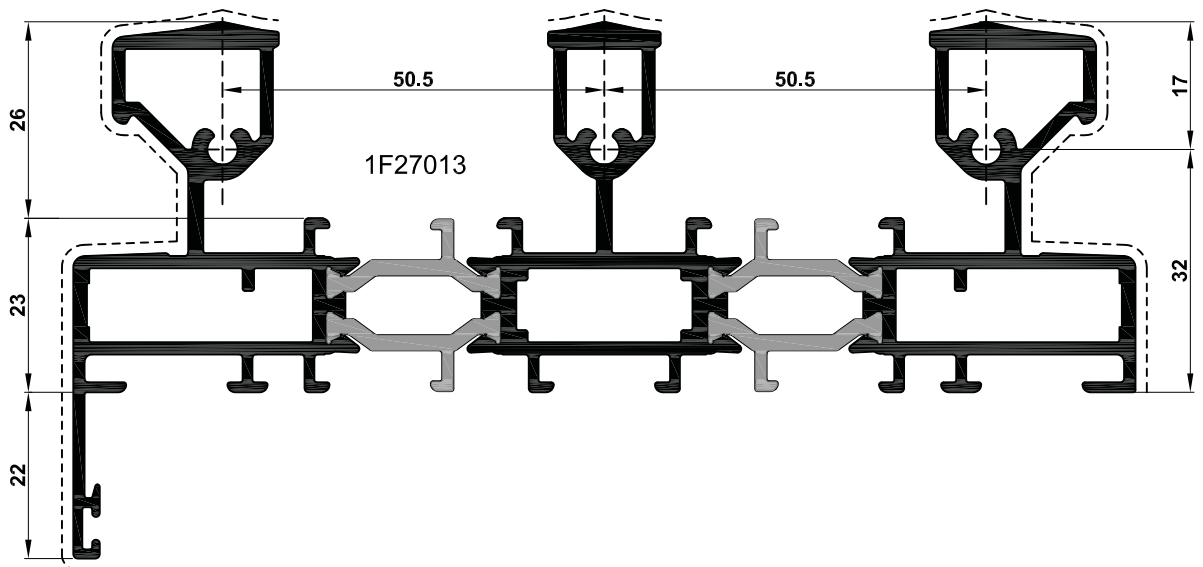
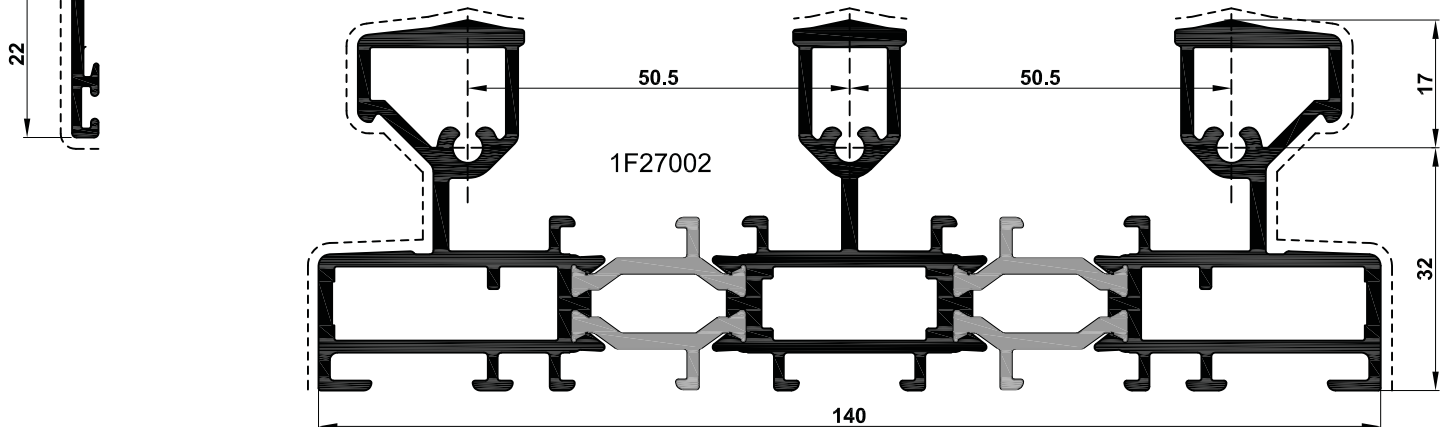
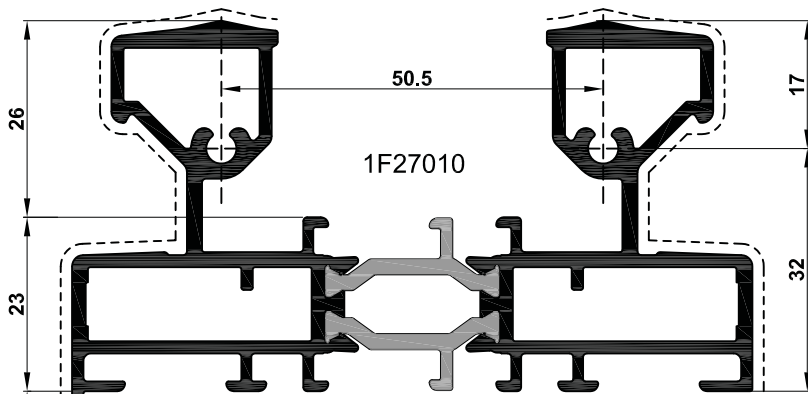
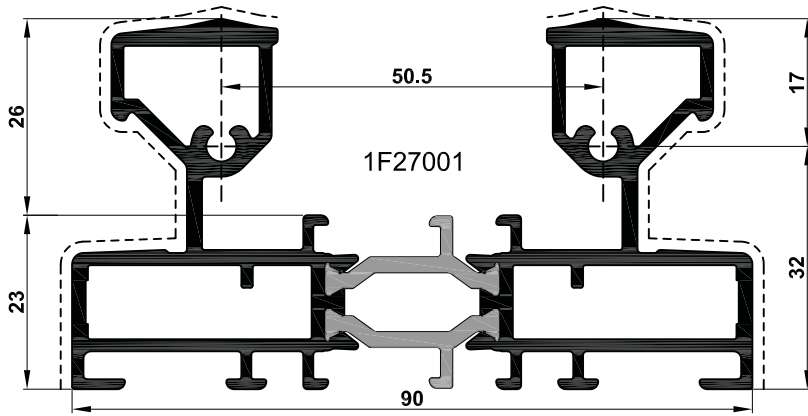

RIPORTI IN PVC - RIGIDO
FILLINGS IN PVC

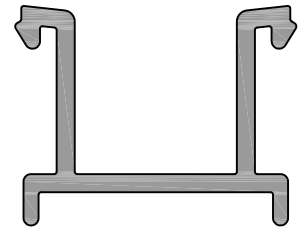

G.0301.QN

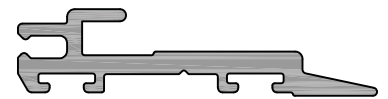

G.0302.QN

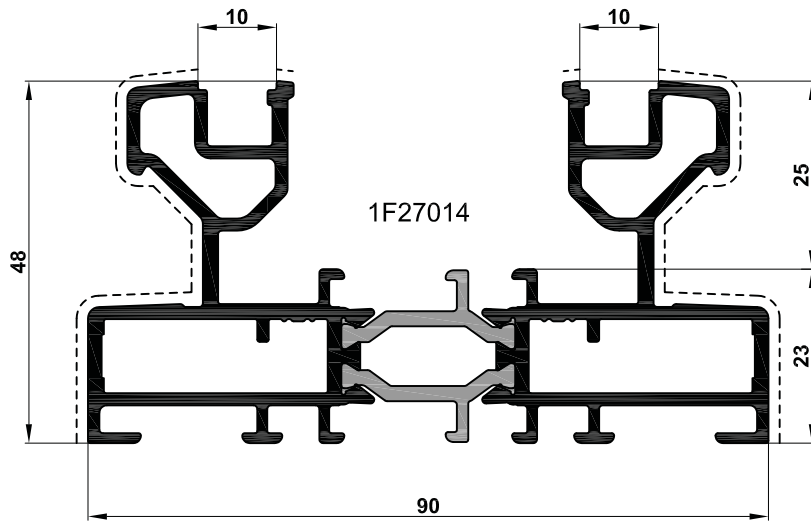

RIPORTO PER TELAIO 1F27014
FILLINGS FOR FRAME 1F27014

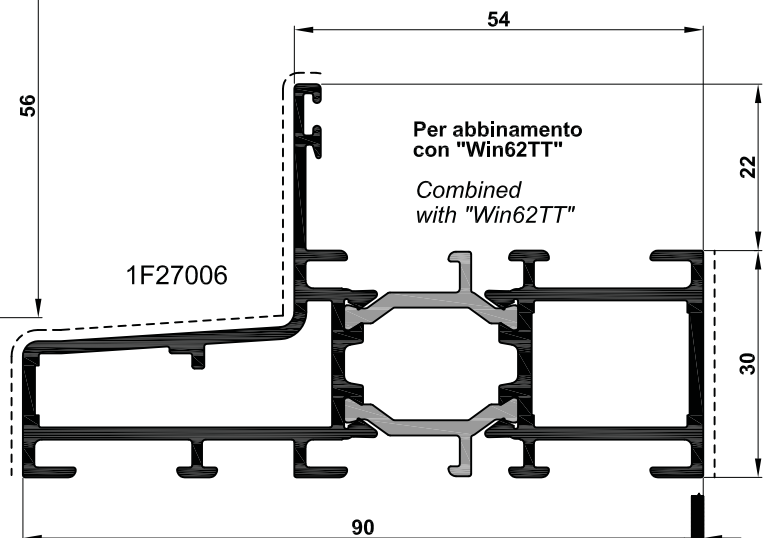
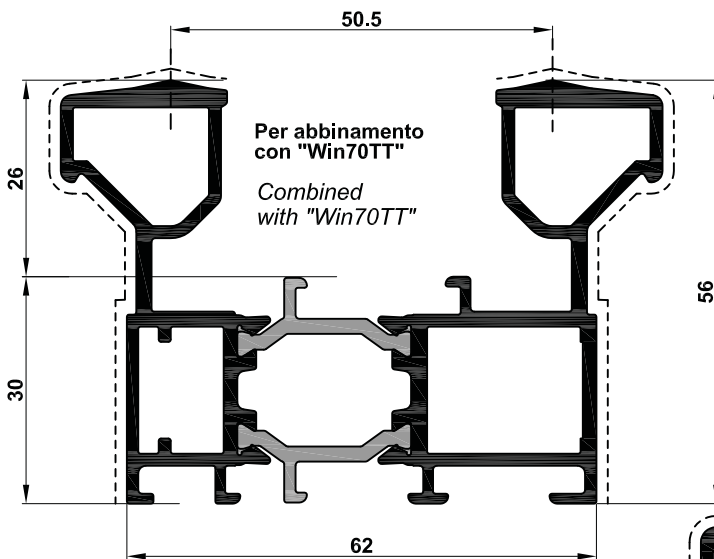
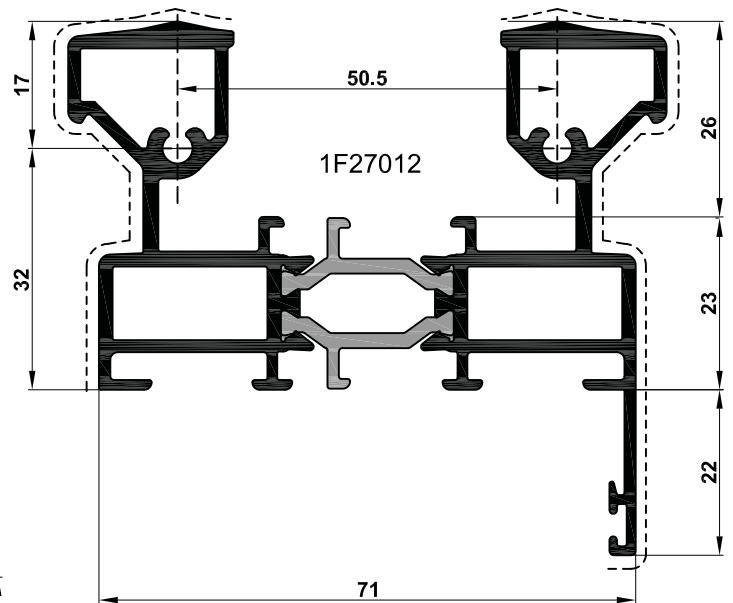
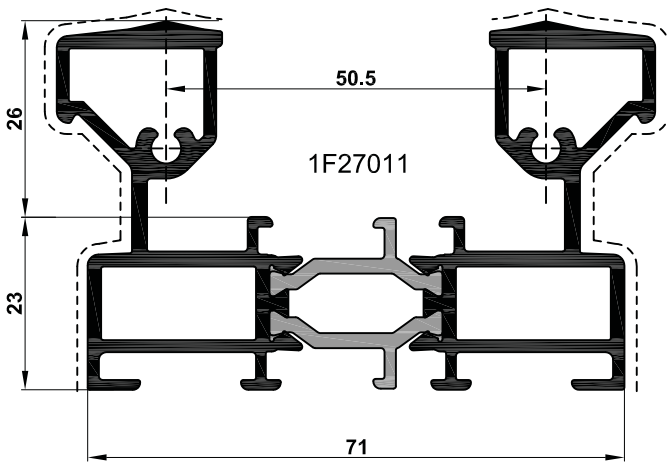
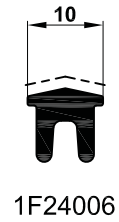

1F27017

VARI
OTHER PIECES

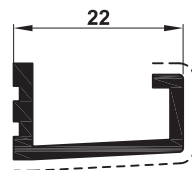
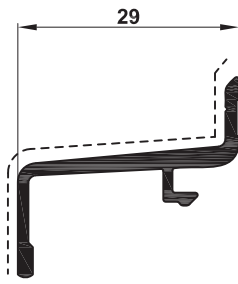
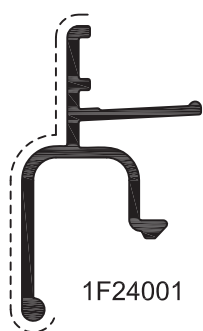

RIPORTO 3^a e 4^a ANTA
3°-4° WING FILLING

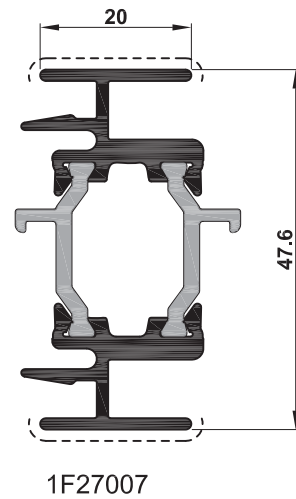

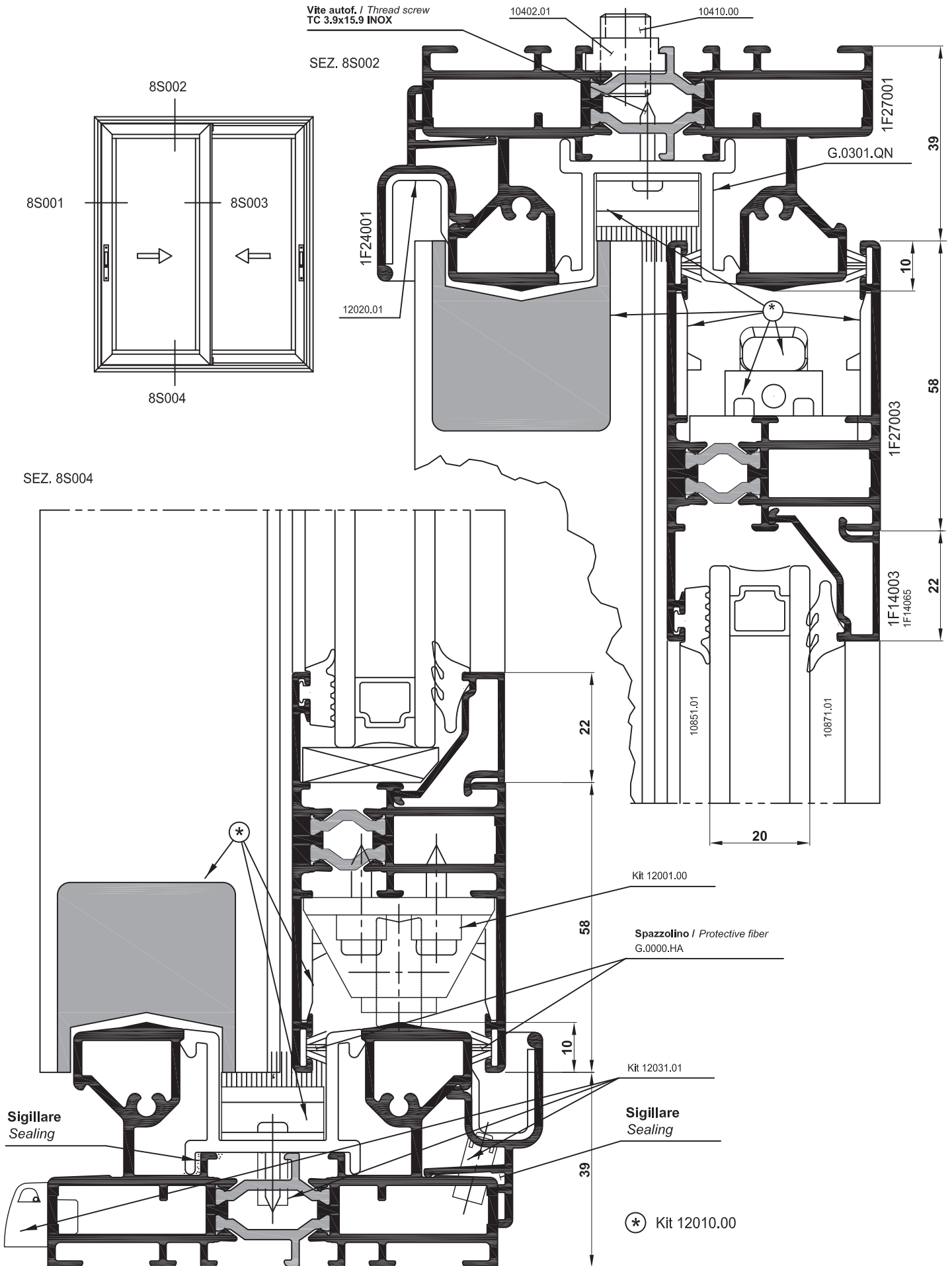

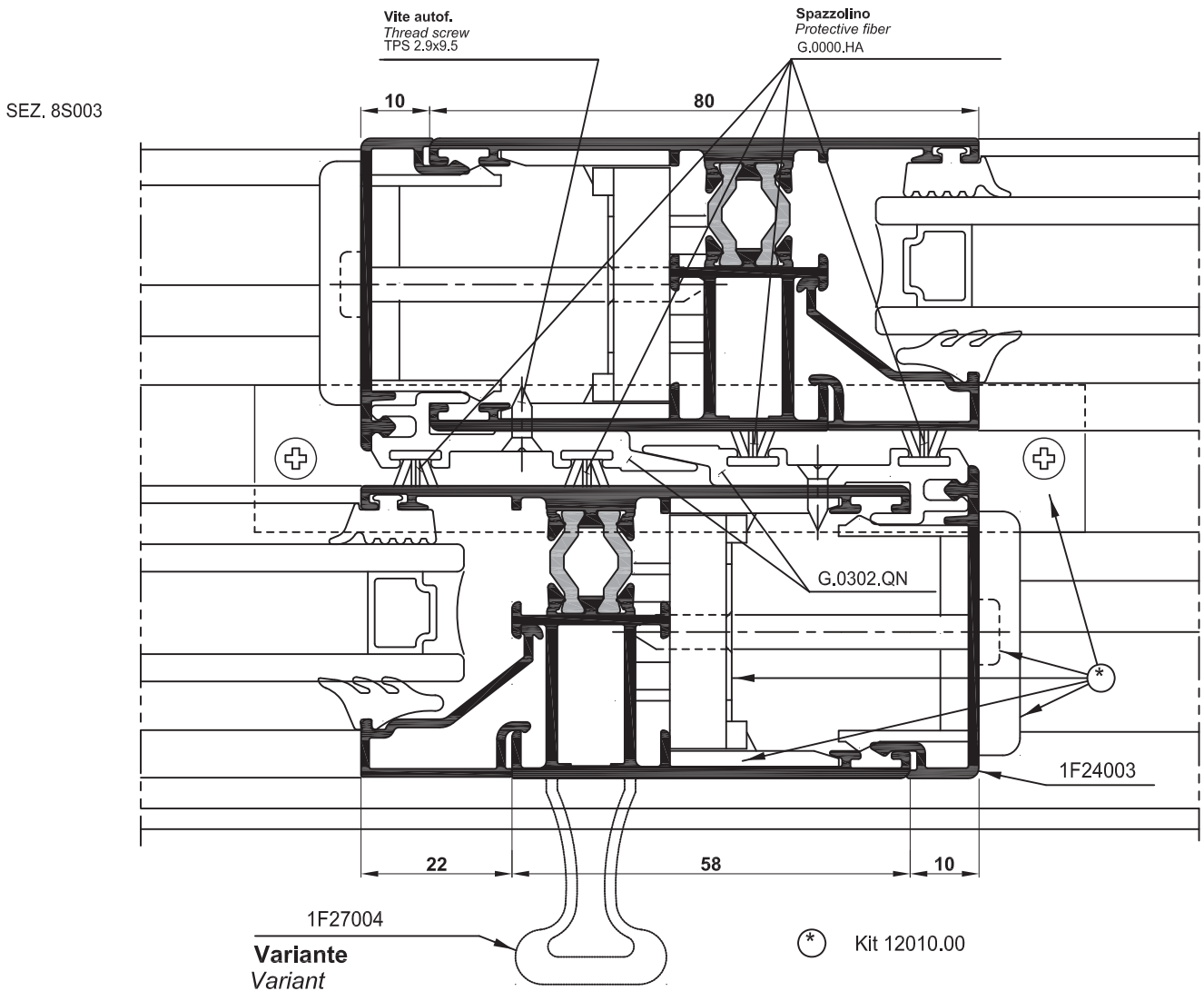
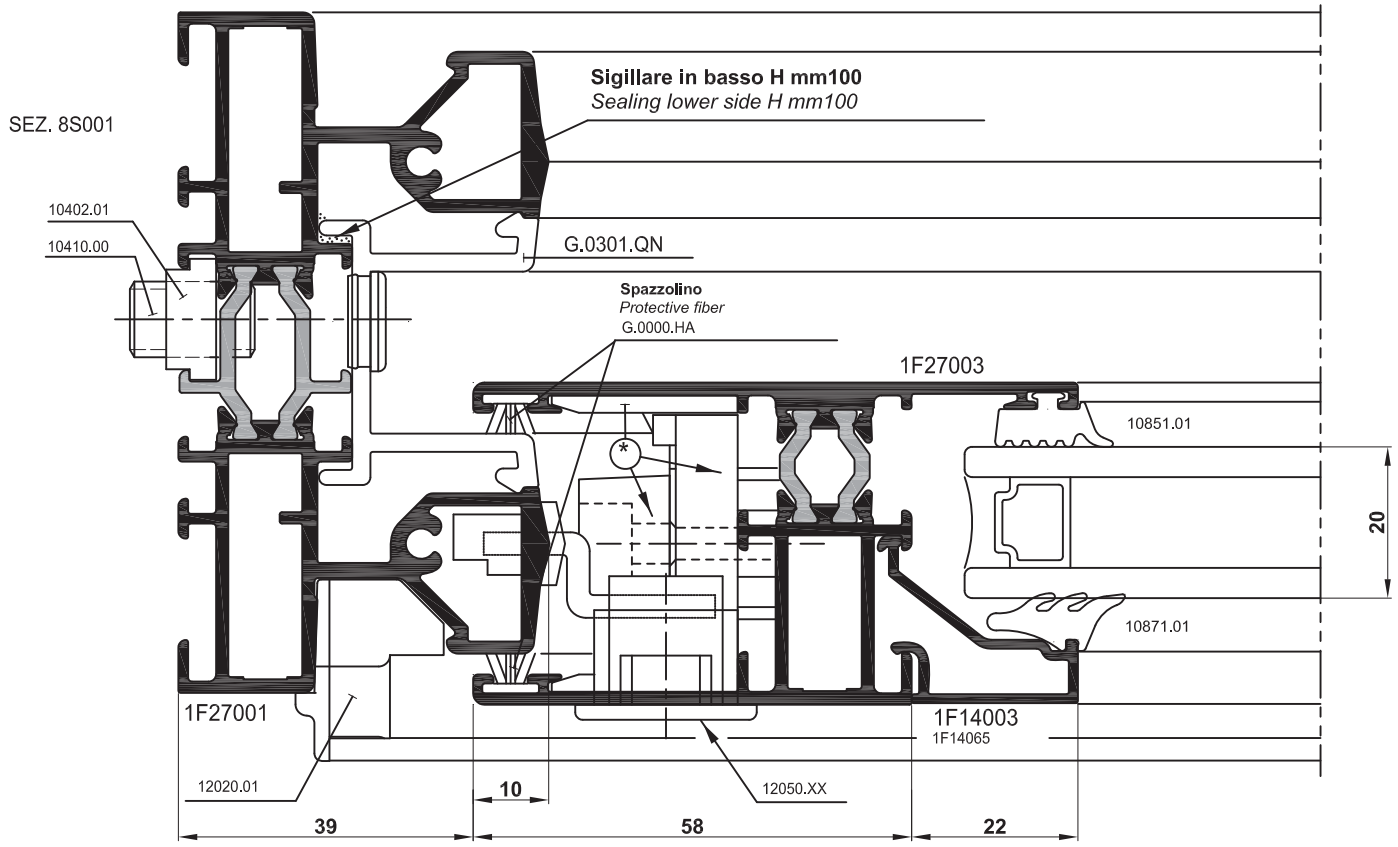

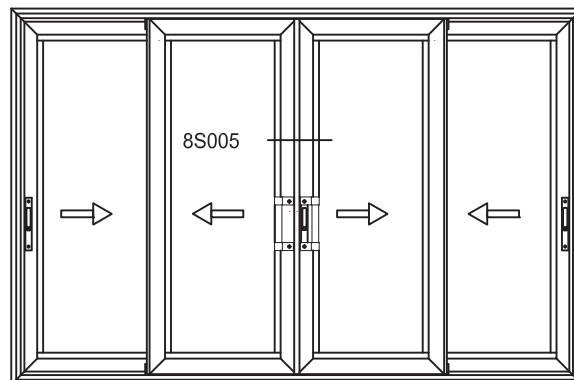
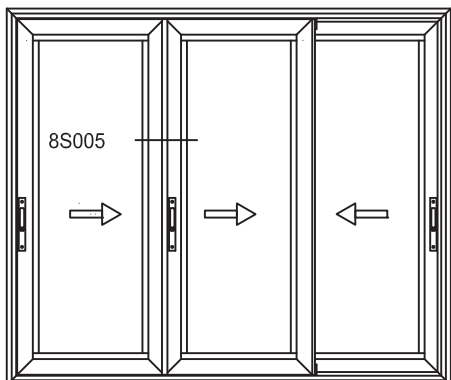

SEZ. 8S005

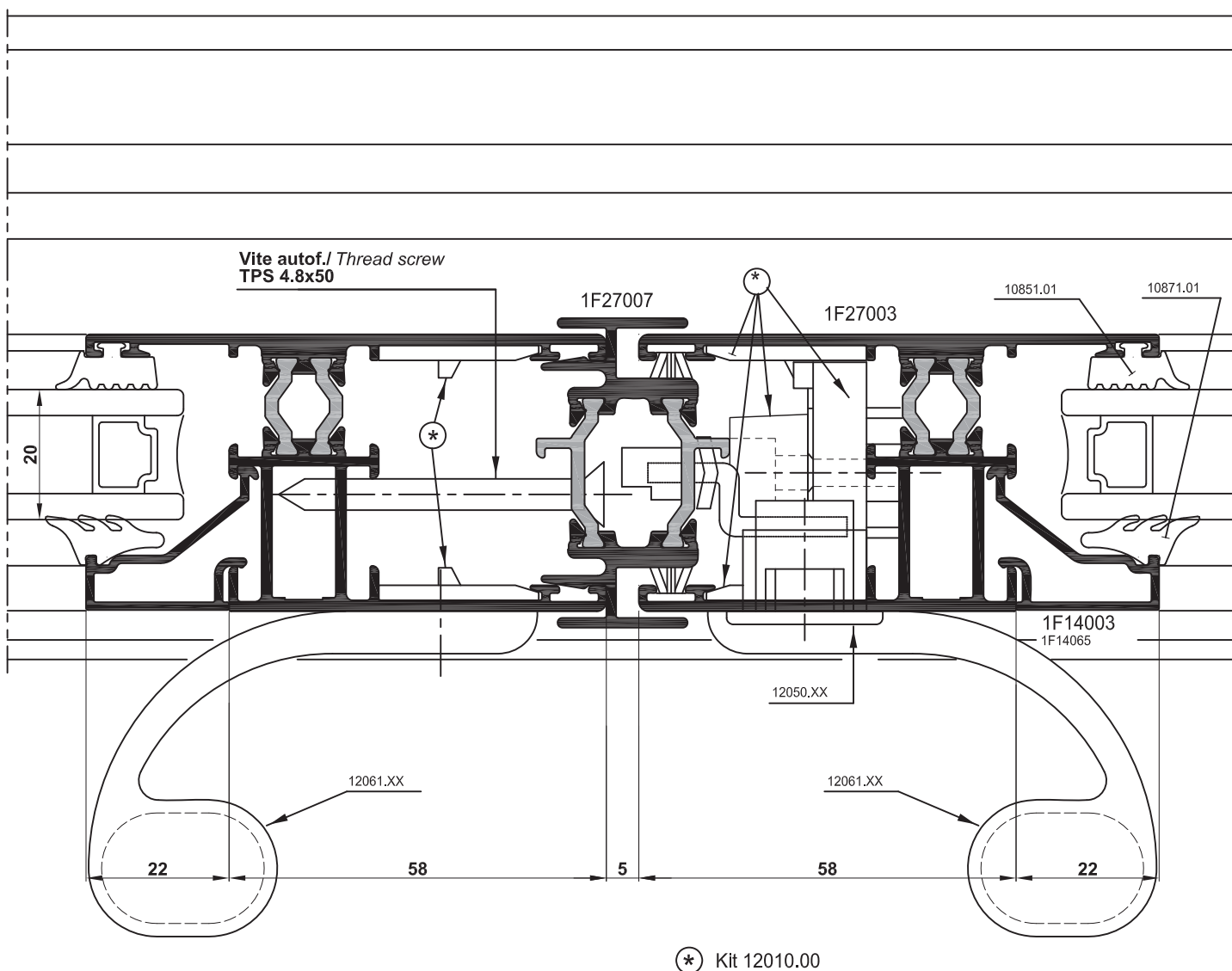

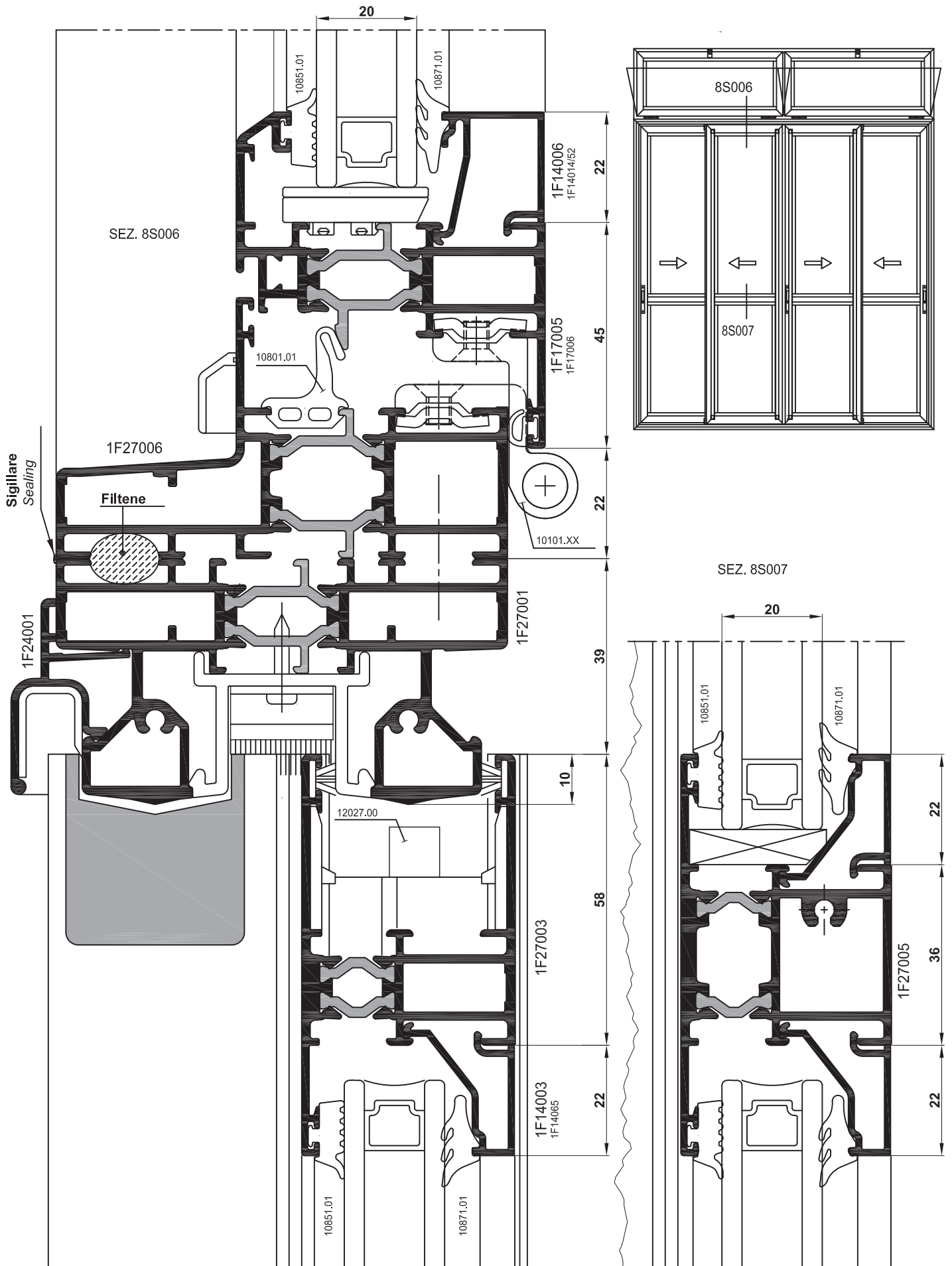

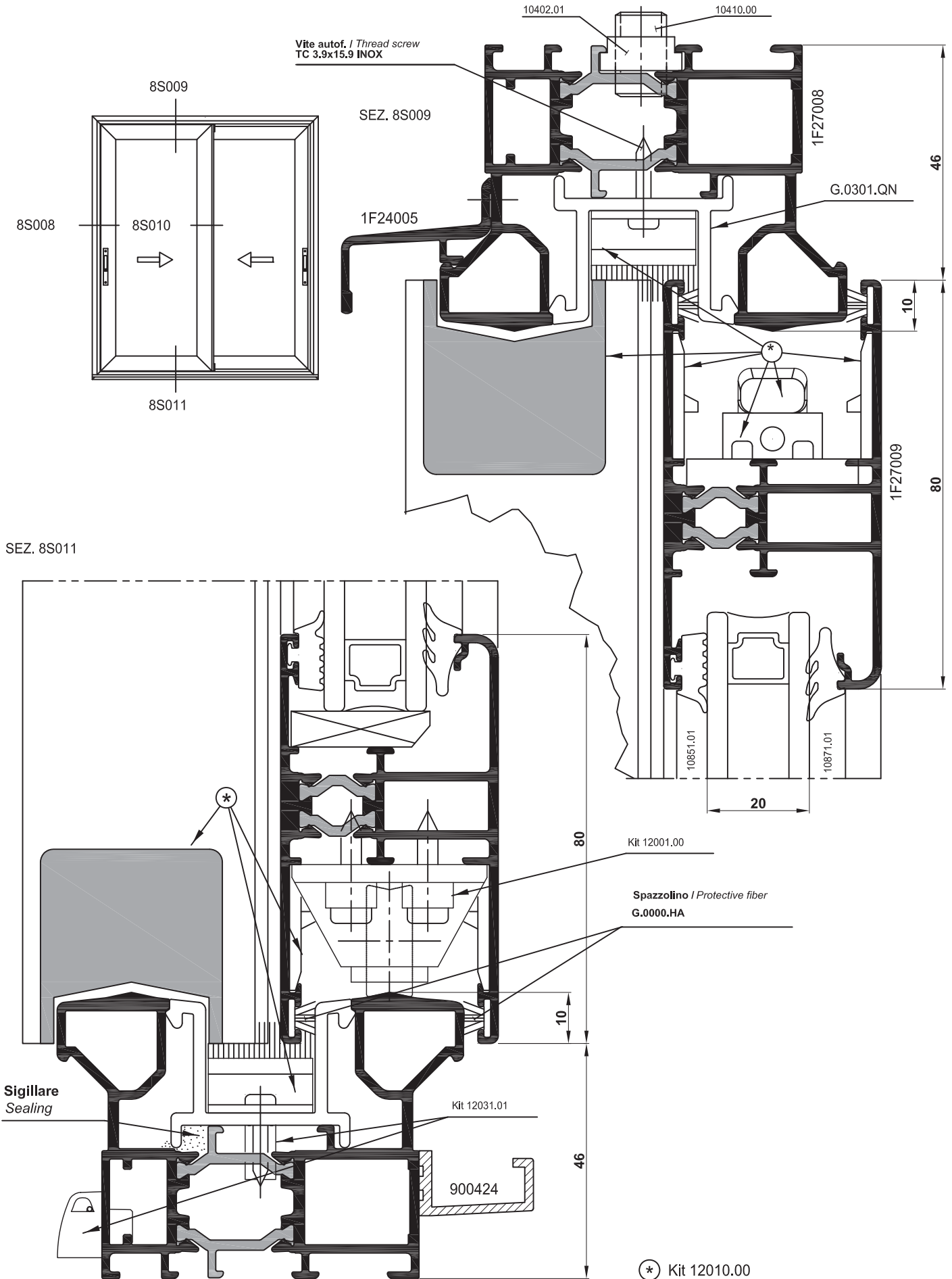

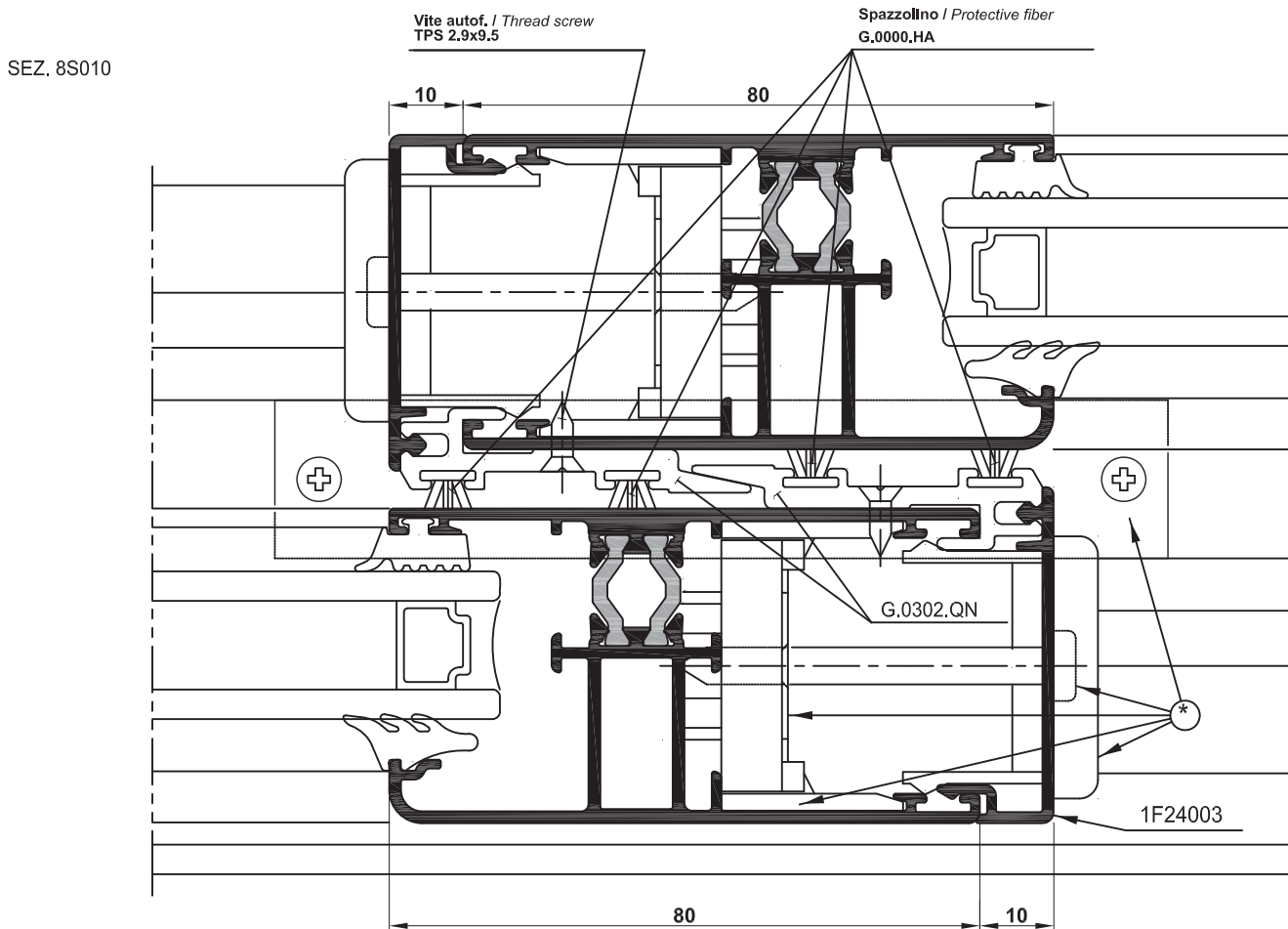
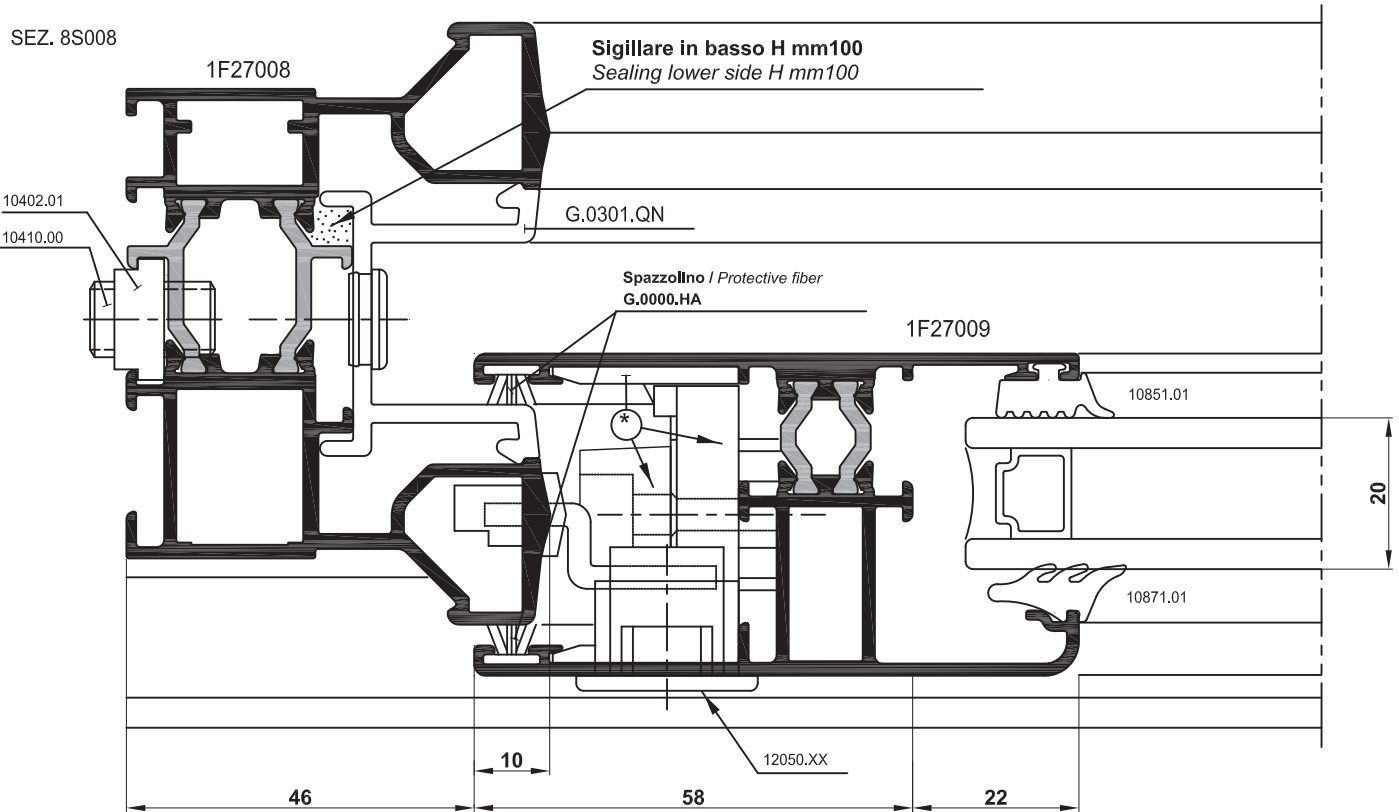

* Kit 12010.00

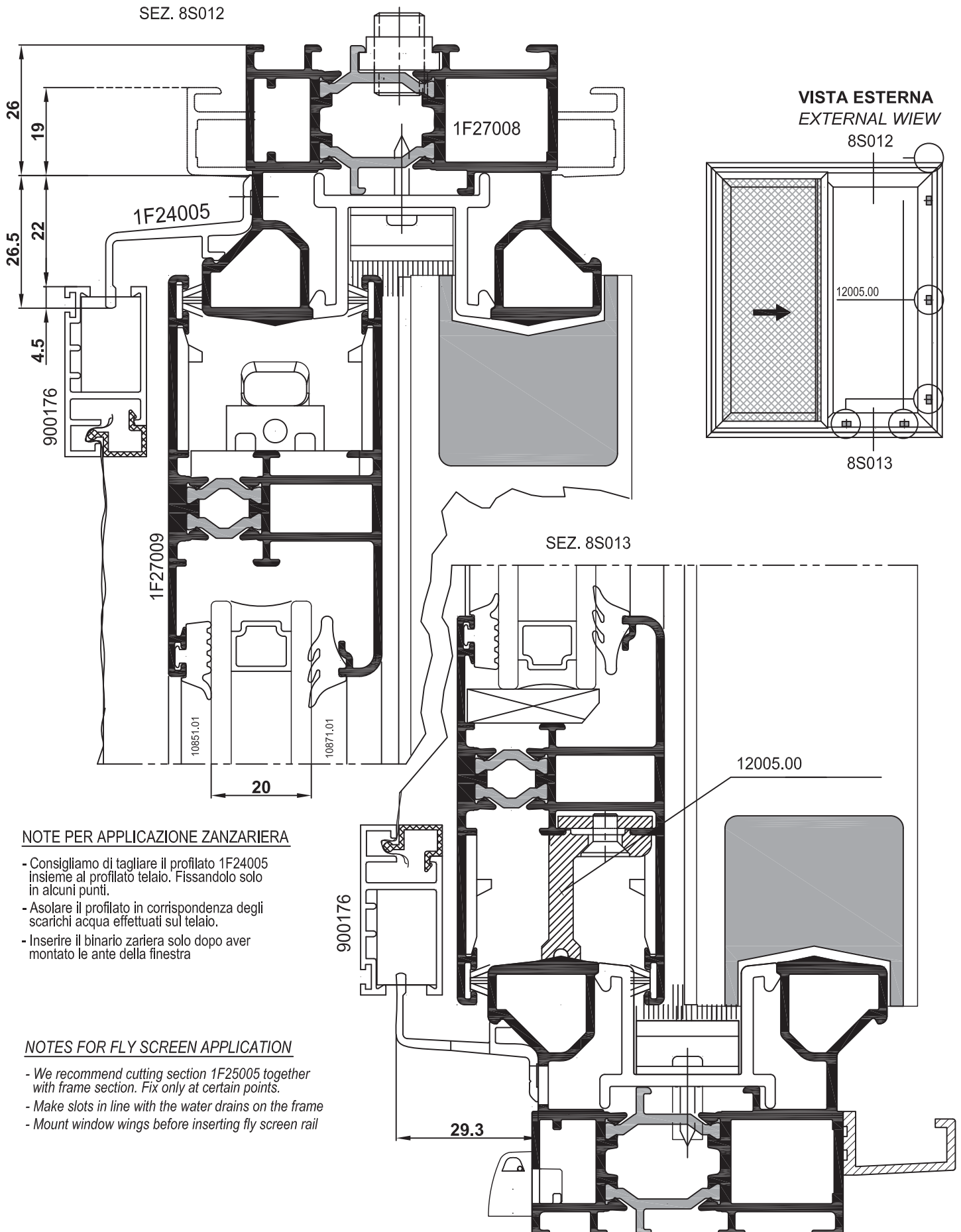

NOTE PER APPLICAZIONE ZANZARIERA

- Consigliamo di tagliare il profilato 1F24005 insieme al profilato telaio. Fissandolo solo in alcuni punti.
- Asolare il profilato in corrispondenza degli scarichi acqua effettuati sul telaio.
- Inserire il binario zanziera solo dopo aver montato le ante della finestra

NOTES FOR FLY SCREEN APPLICATION

- We recommend cutting section 1F25005 together with frame section. Fix only at certain points.
- Make slots in line with the water drains on the frame
- Mount window wings before inserting fly screen rail

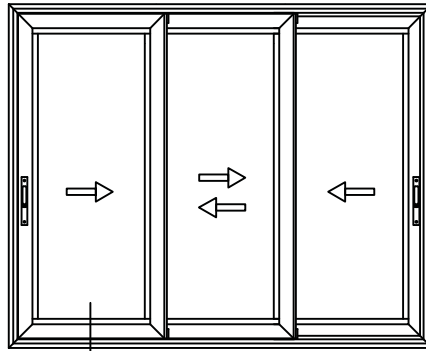

8S014

SEZ. 8S014

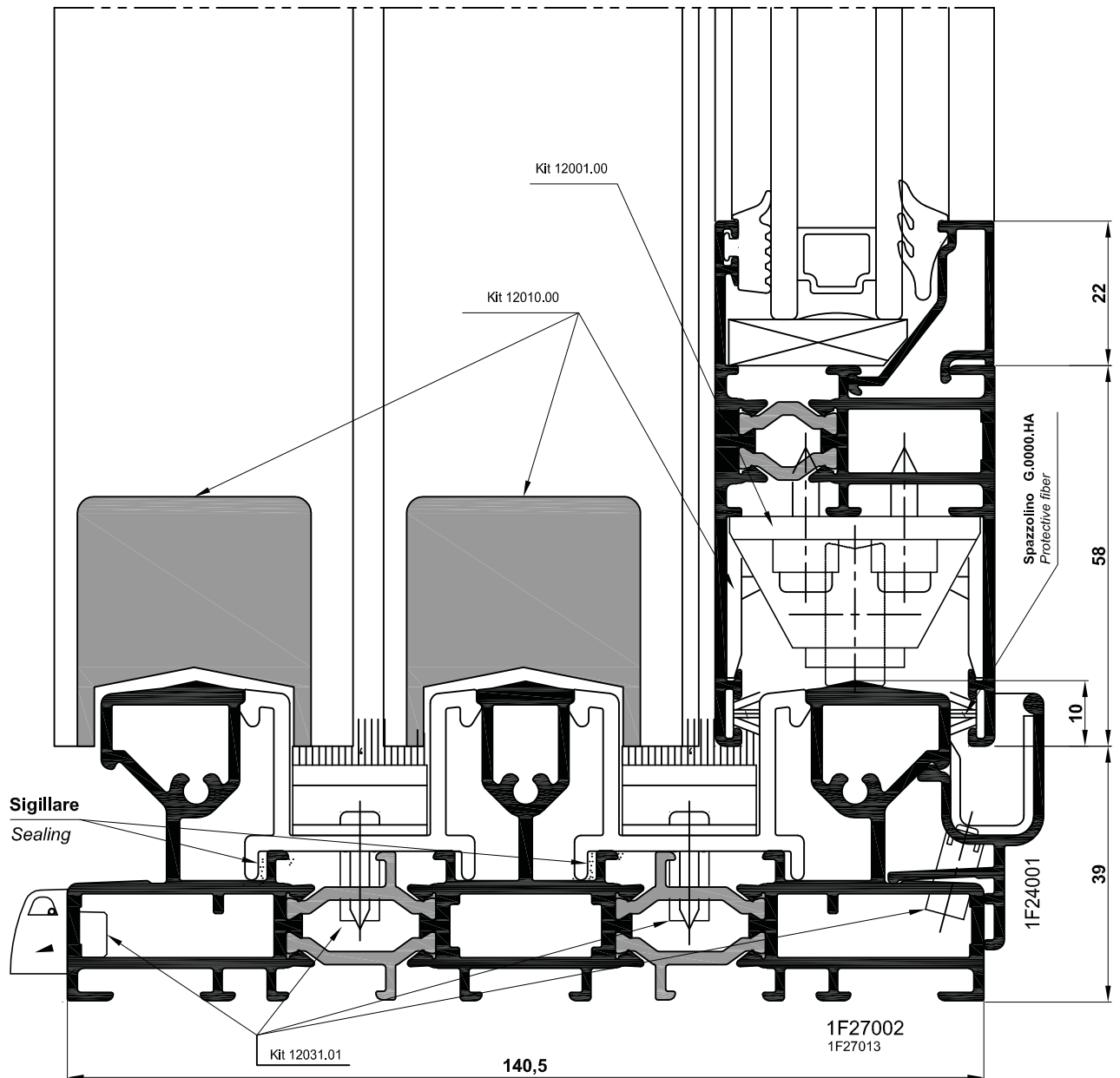

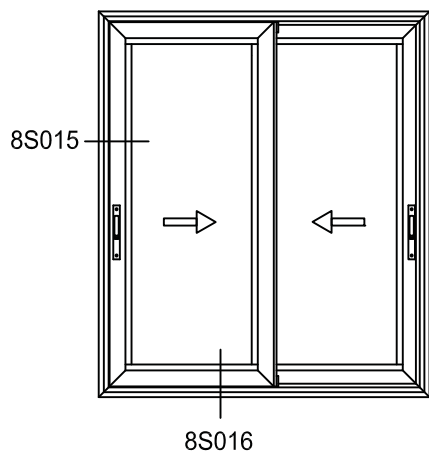

SEZ. 8S015

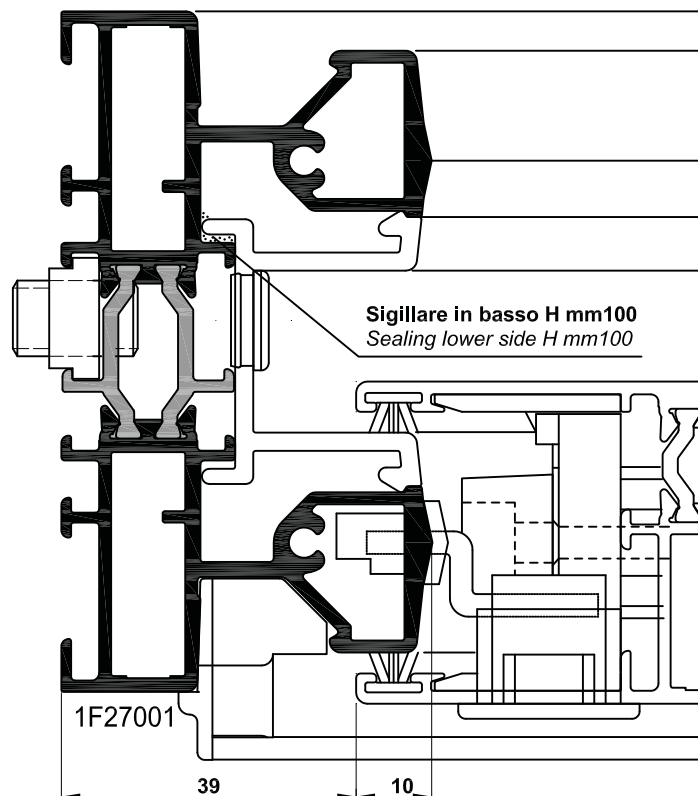

SEZ. 8S016

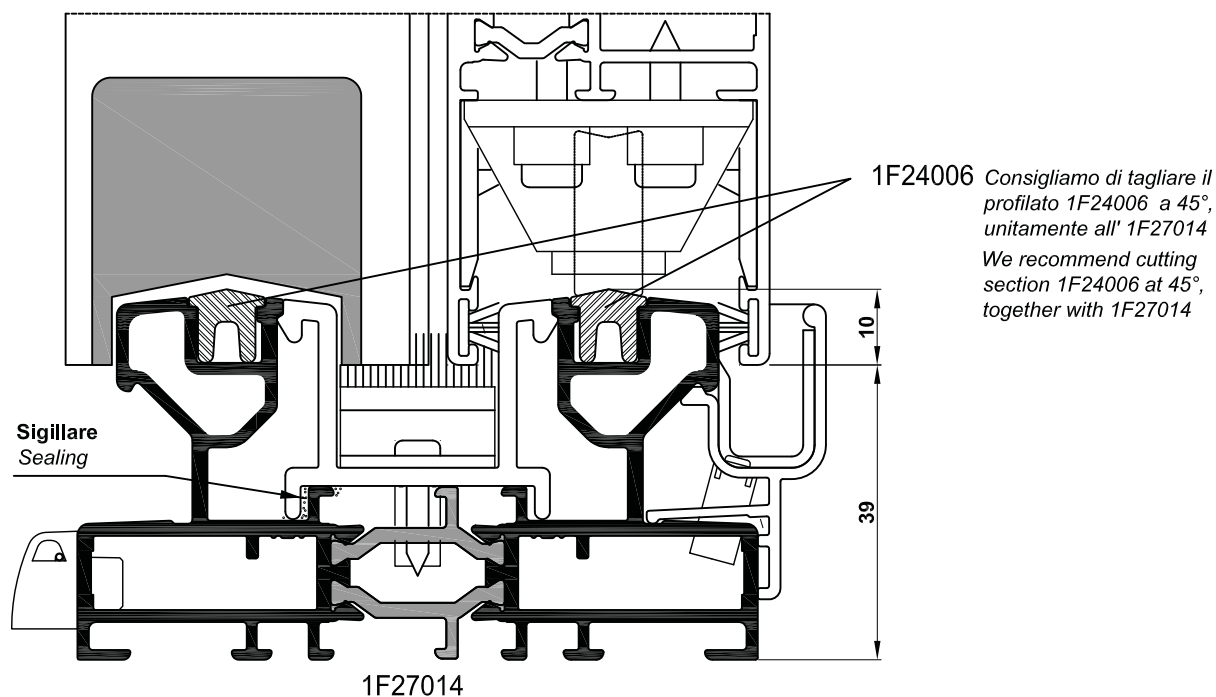

SEZ. 8S016

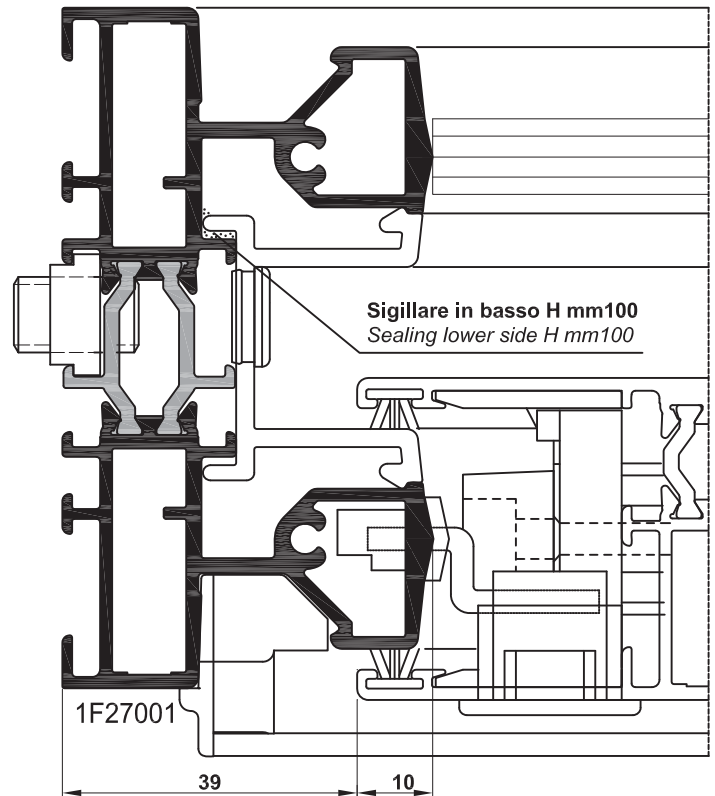
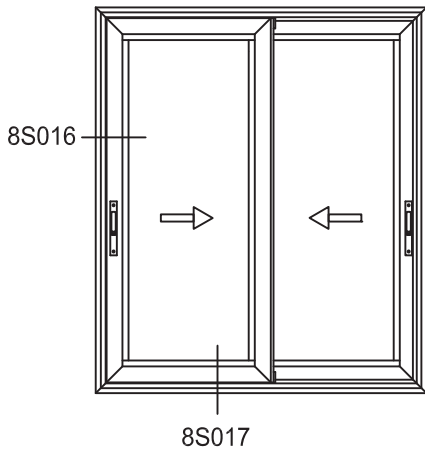







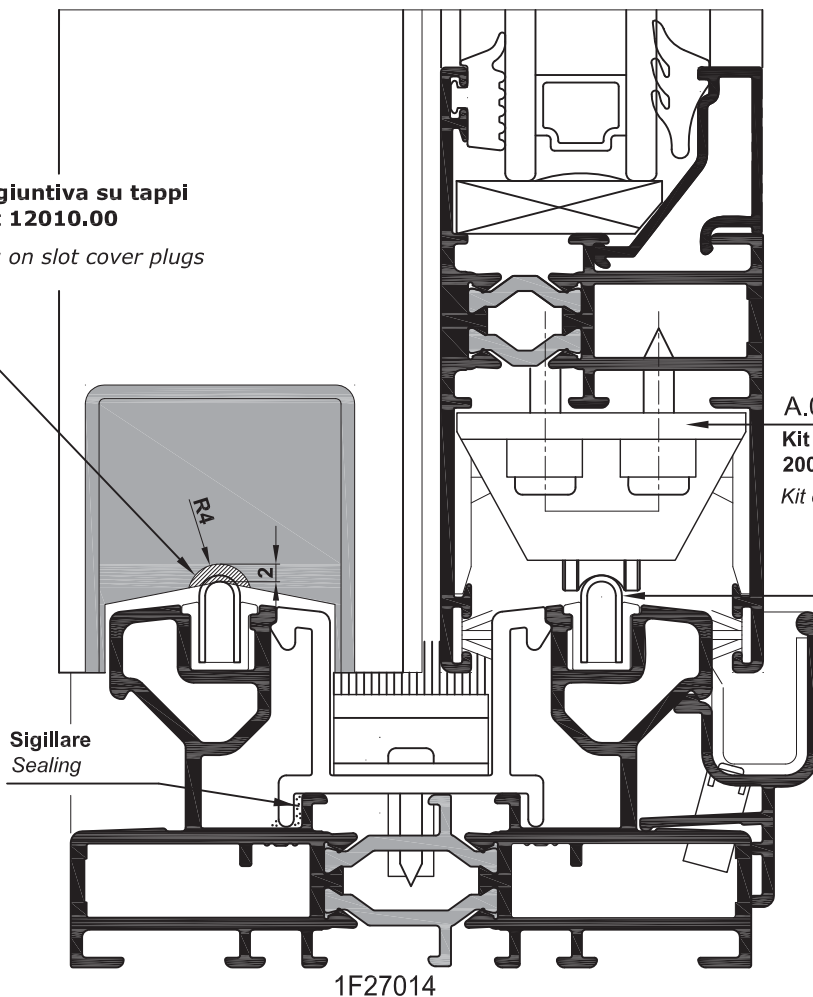

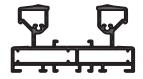

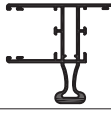
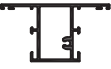
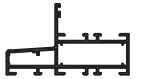

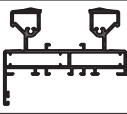

SEZ. 8S017

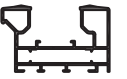
Lavorazione aggiuntiva su tappi copriferritoie Kit 12010.00

Additional tooling on slot cover plugs 12010.00 kit



Profilato Section	Sezione Cross section 	Peso Weight Kg/m	Perimetro Perimeter mm	Superficie in vista Exposed surface m ² /m	Jx cm ⁴	Wx cm ³	Jy cm ⁴	Wy cm ³
1F22001		2,166	520	0,176	18,43	6,80	62,17	13,79
1F22002		2,993	735	0,191	24,85	9,02	209,87	29,87
1F22003		1,131	440	0,150	14,89	3,63	12,40	5,41
1F22004		1,650	514	0,224	16,28	3,94	38,92	9,93
1F22005		1,044	348	0,123	9,63	3,97	11,82	2,90
1F22006		1,444	447	0,117	7,43	2,04	39,00	8,42
1F22007		0,634	231	0,077	5,96	2,51	0,95	0,71
1F22010		2,273	579	0,202	22,97	5,44	69,54	14,80
1F22011		1,858	497	0,176	21,90	5,13	48,98	10,89
1F22012		1,245	489	0,177	20,90	4,89	14,21	6,66
1F22013		2,191	461	0,245	20,18	7,45	58,60	13,02
1F22014		1,733	435	0,146	15,76	6,12	13,99	10,31
1F24001		0,328	167	0,087	-	-	-	-
1F24002		0,596	281	0,095	-	-	-	-
1F24004		0,349	215	0,078	-	-	-	-
1F24005		0,279	120	0,051	-	-	-	-
900424		0,219	93	0,037	-	-	-	-

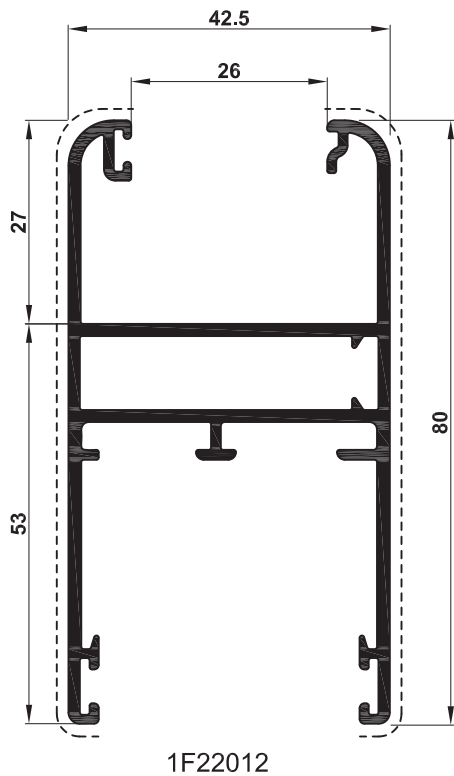
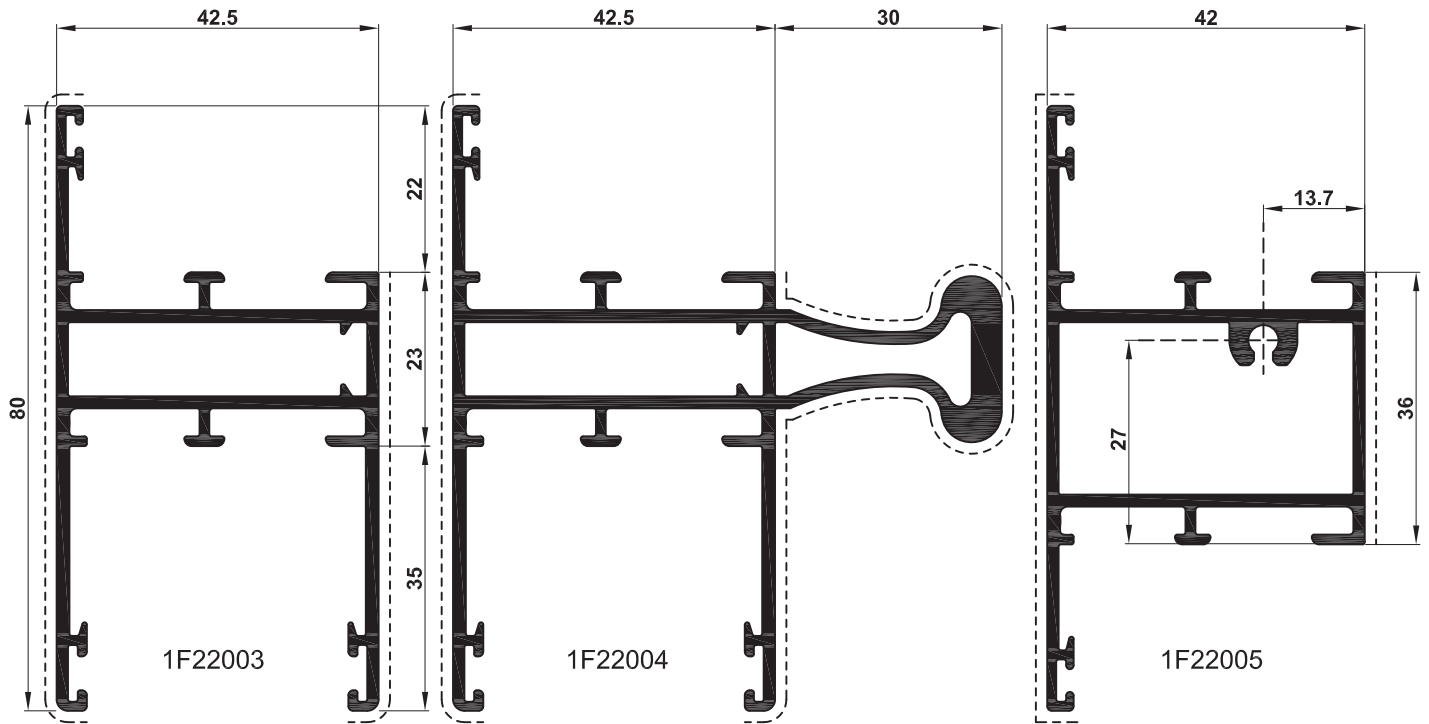

VARI
OTHER PIECES

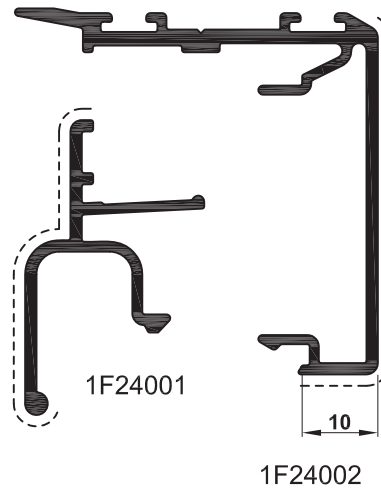

RIPORTO 3^a e 4^a ANTA
3°-4° WING FILLING

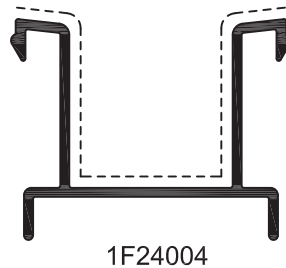
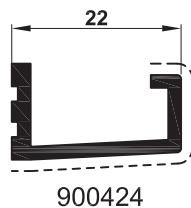
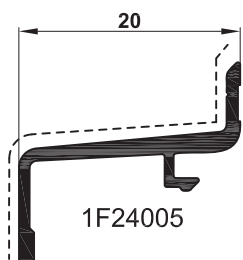
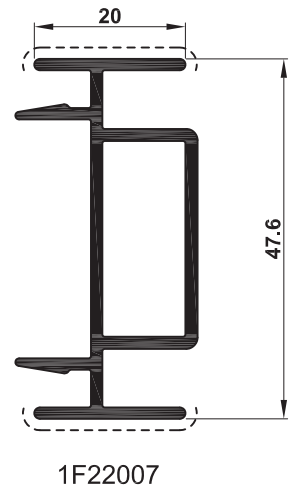

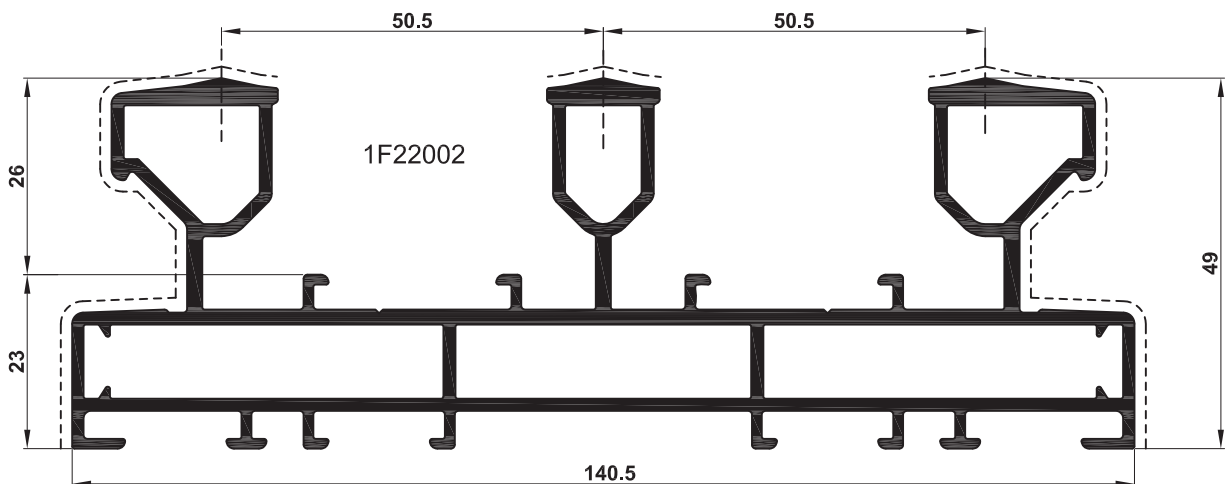
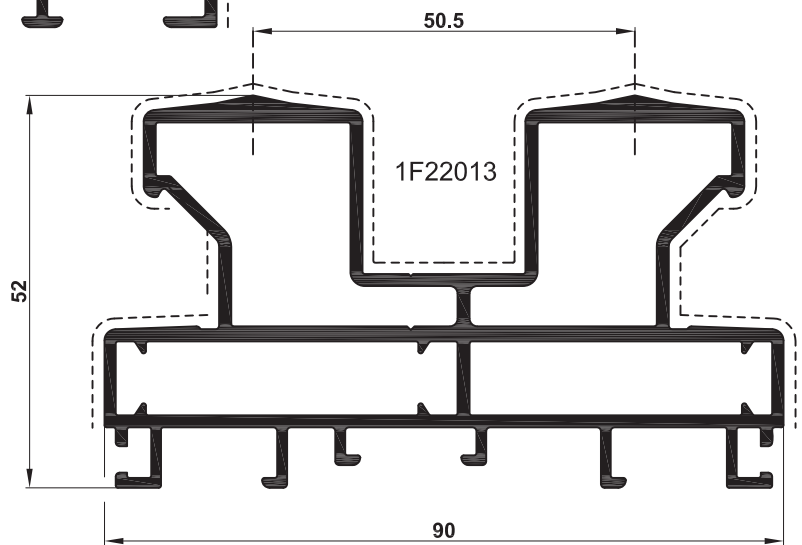
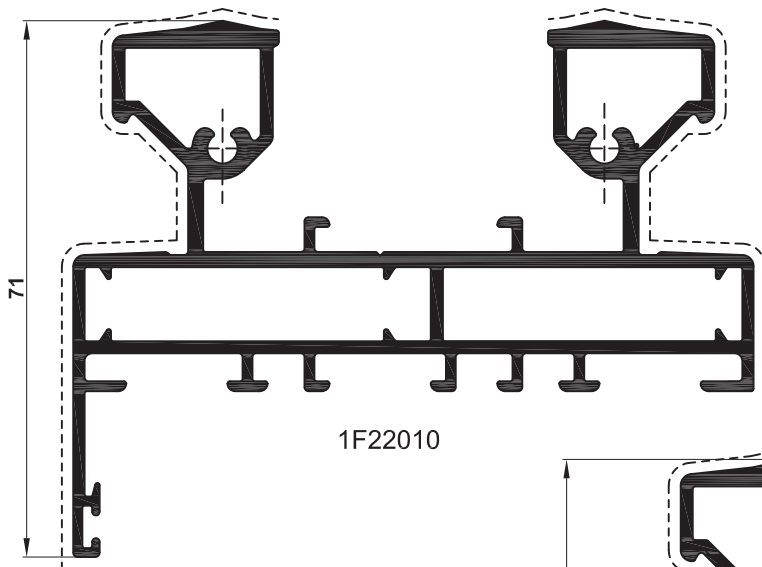
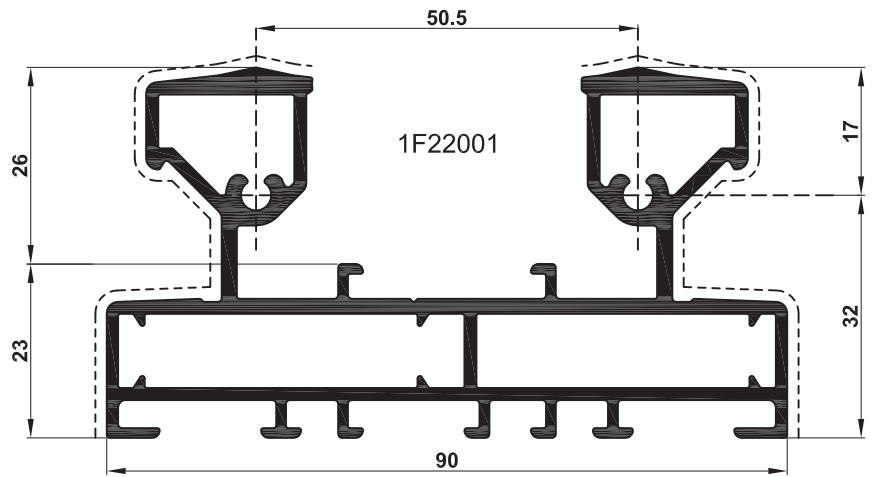

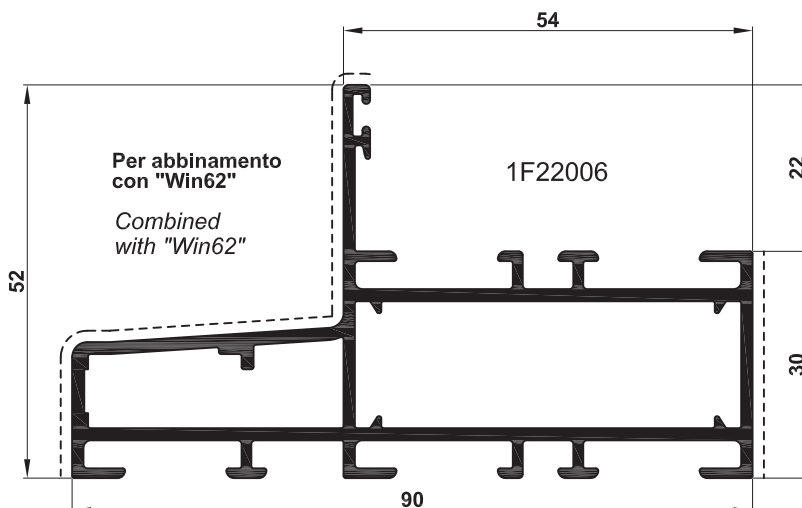
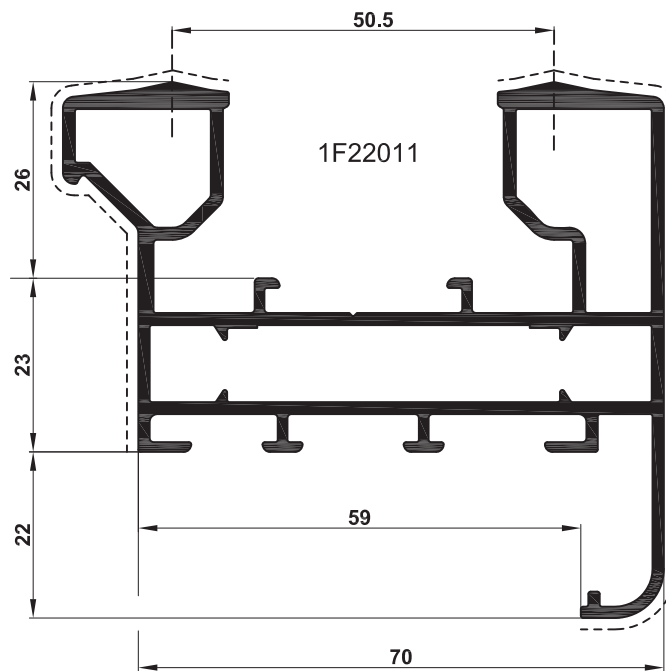
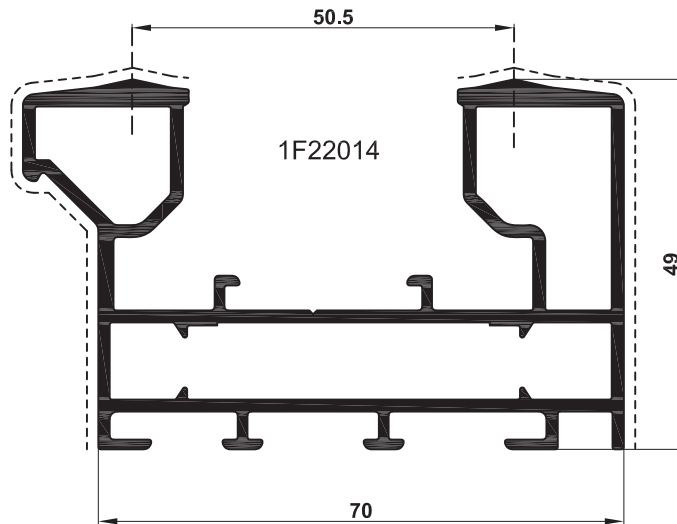

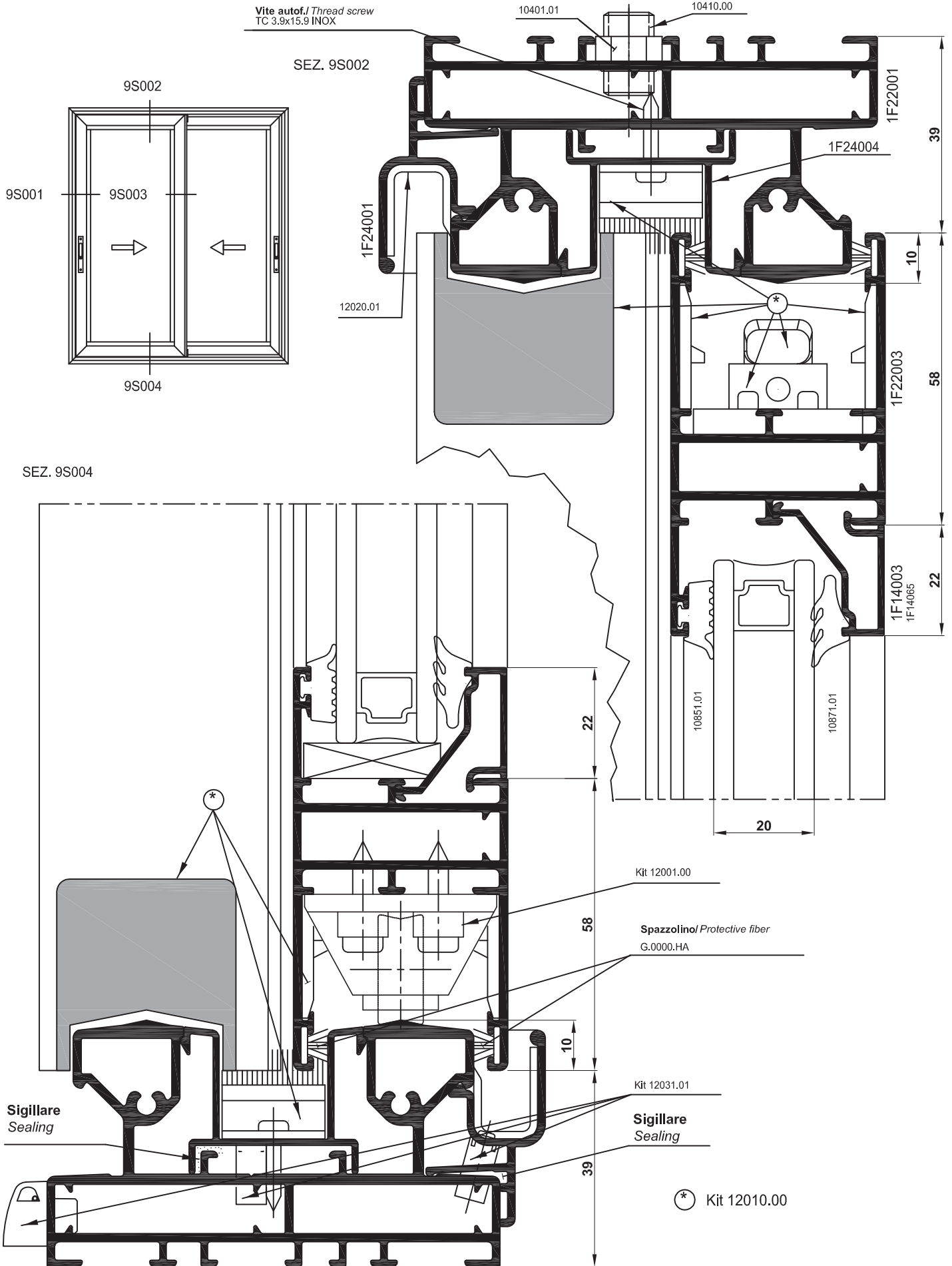

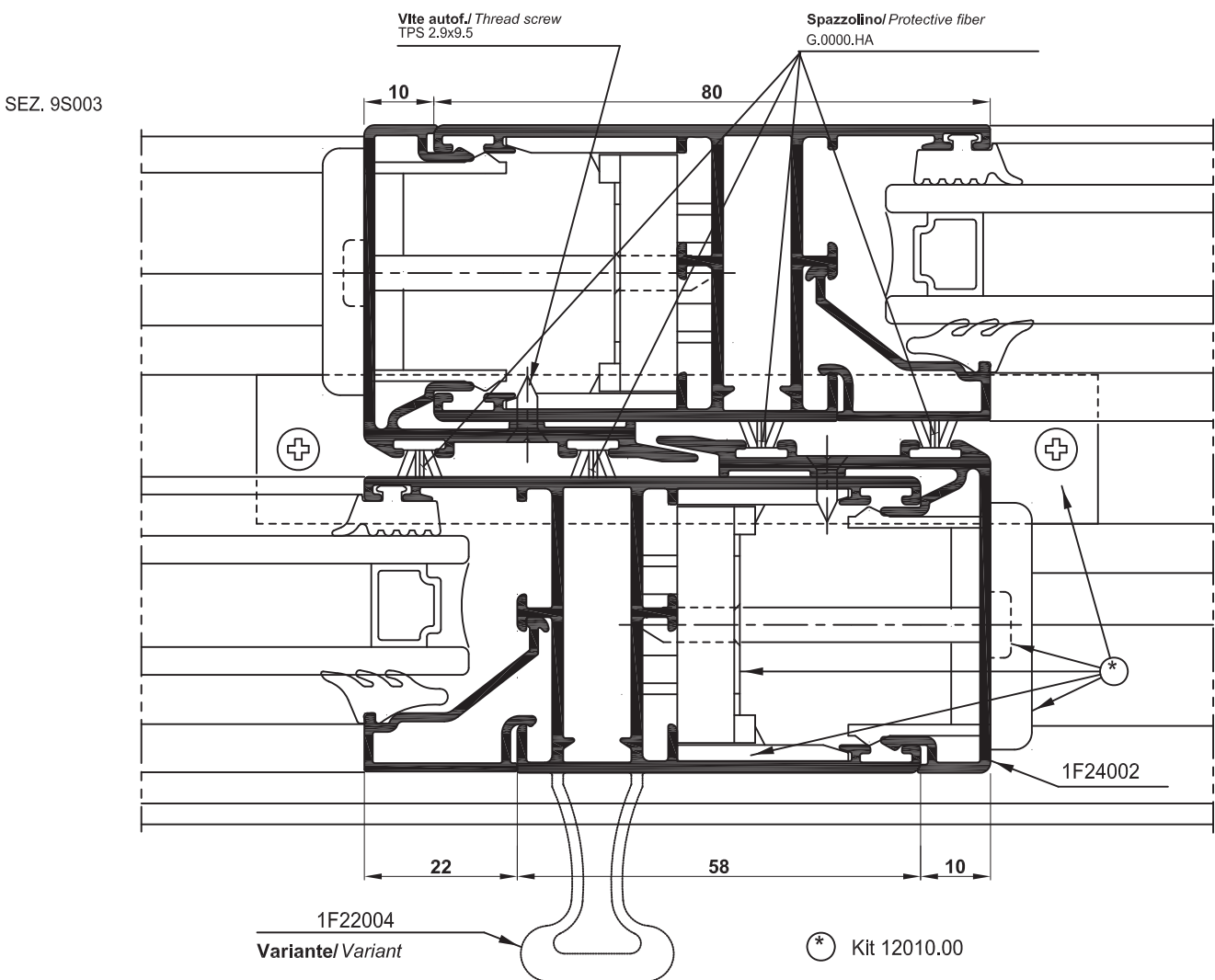
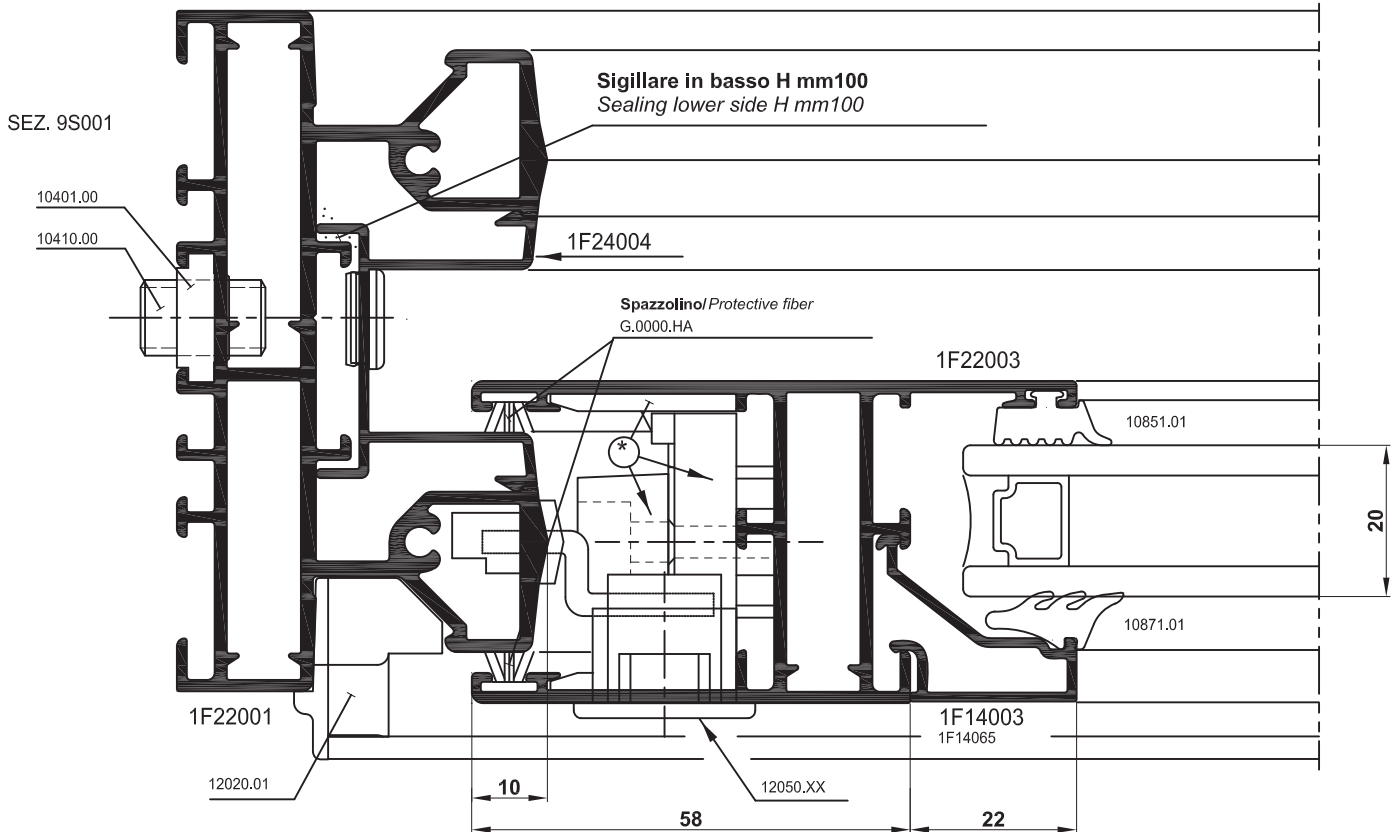

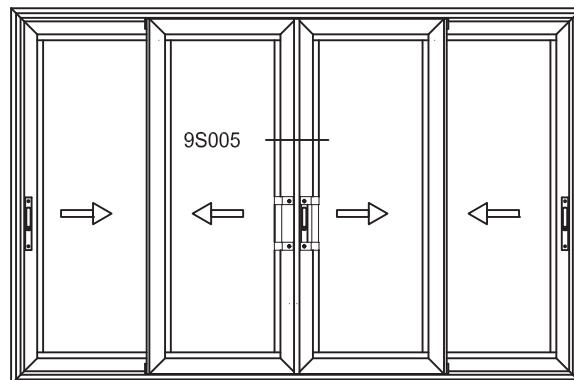
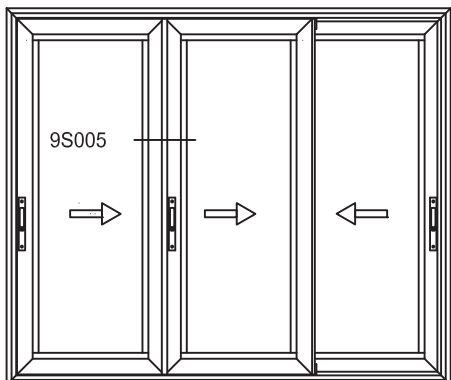

SEZ. 9S005

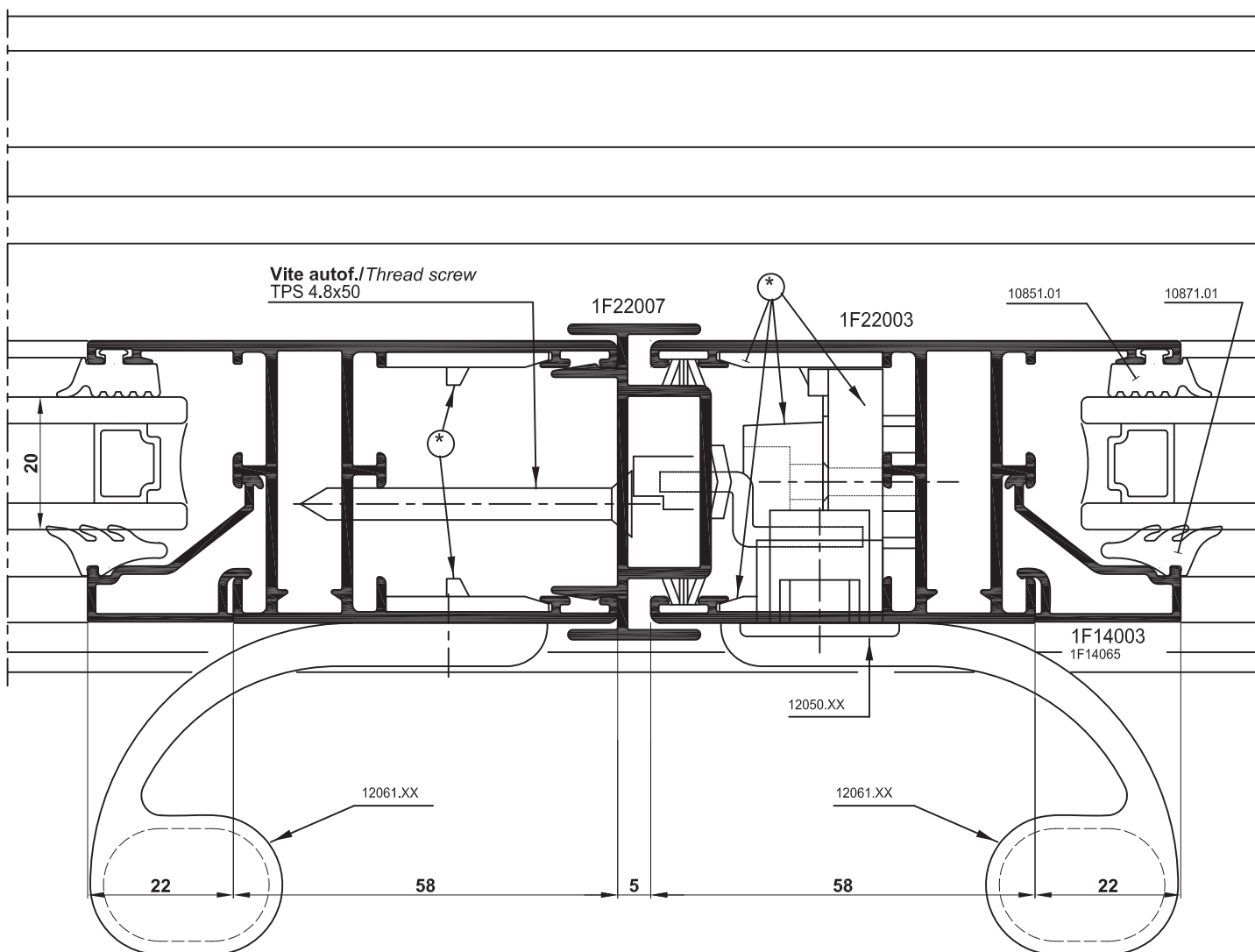

* Kit 12010.00

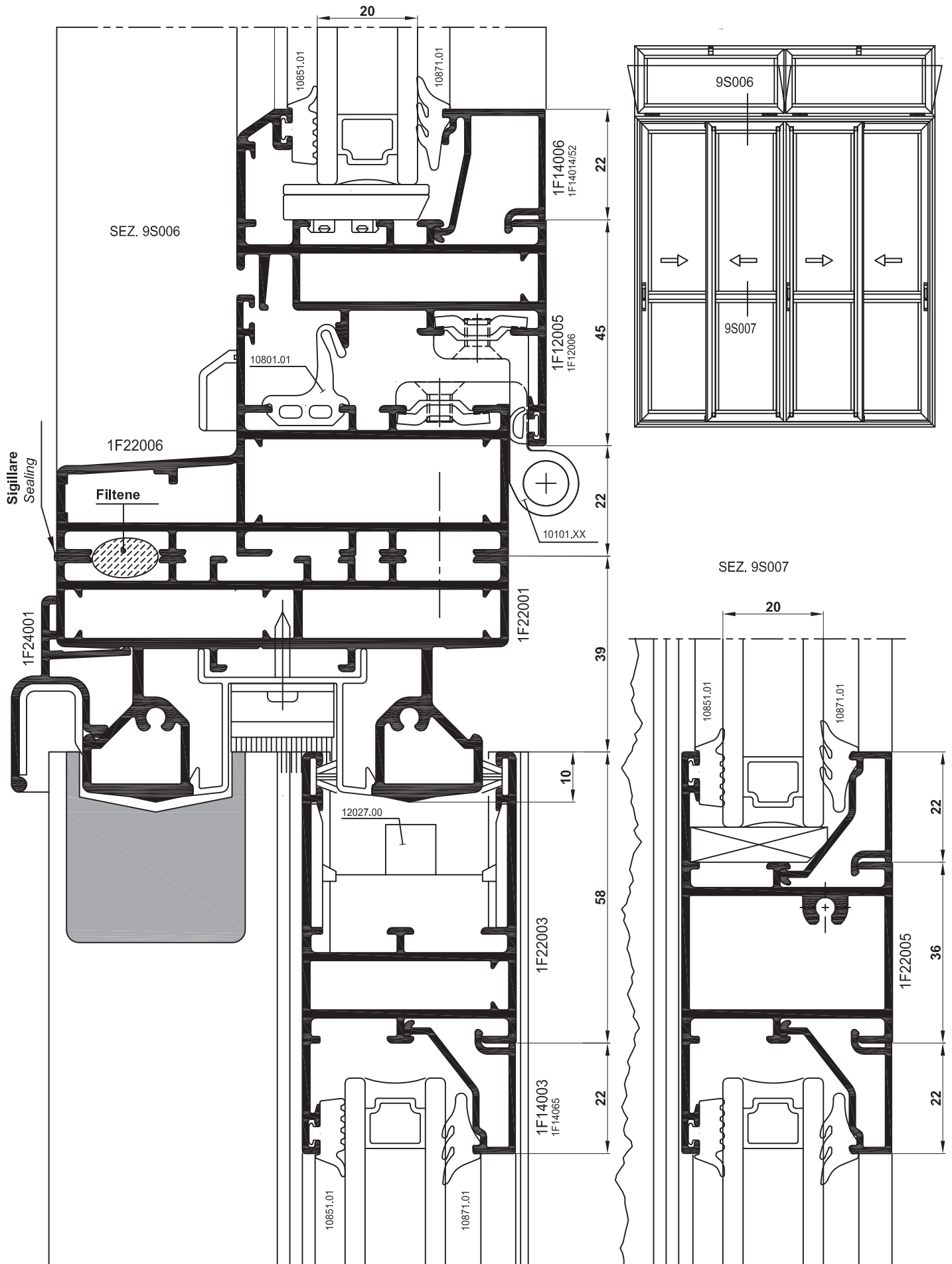

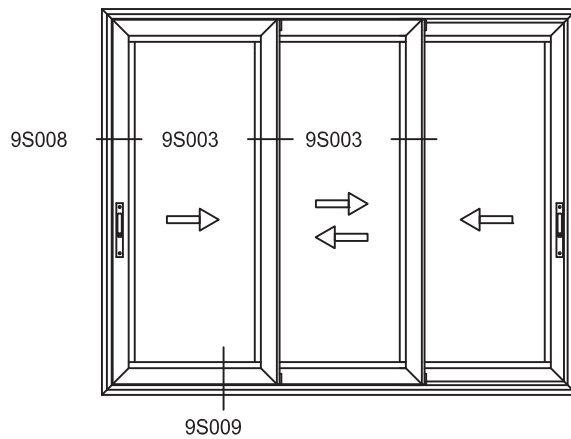

SEZ. 9S008

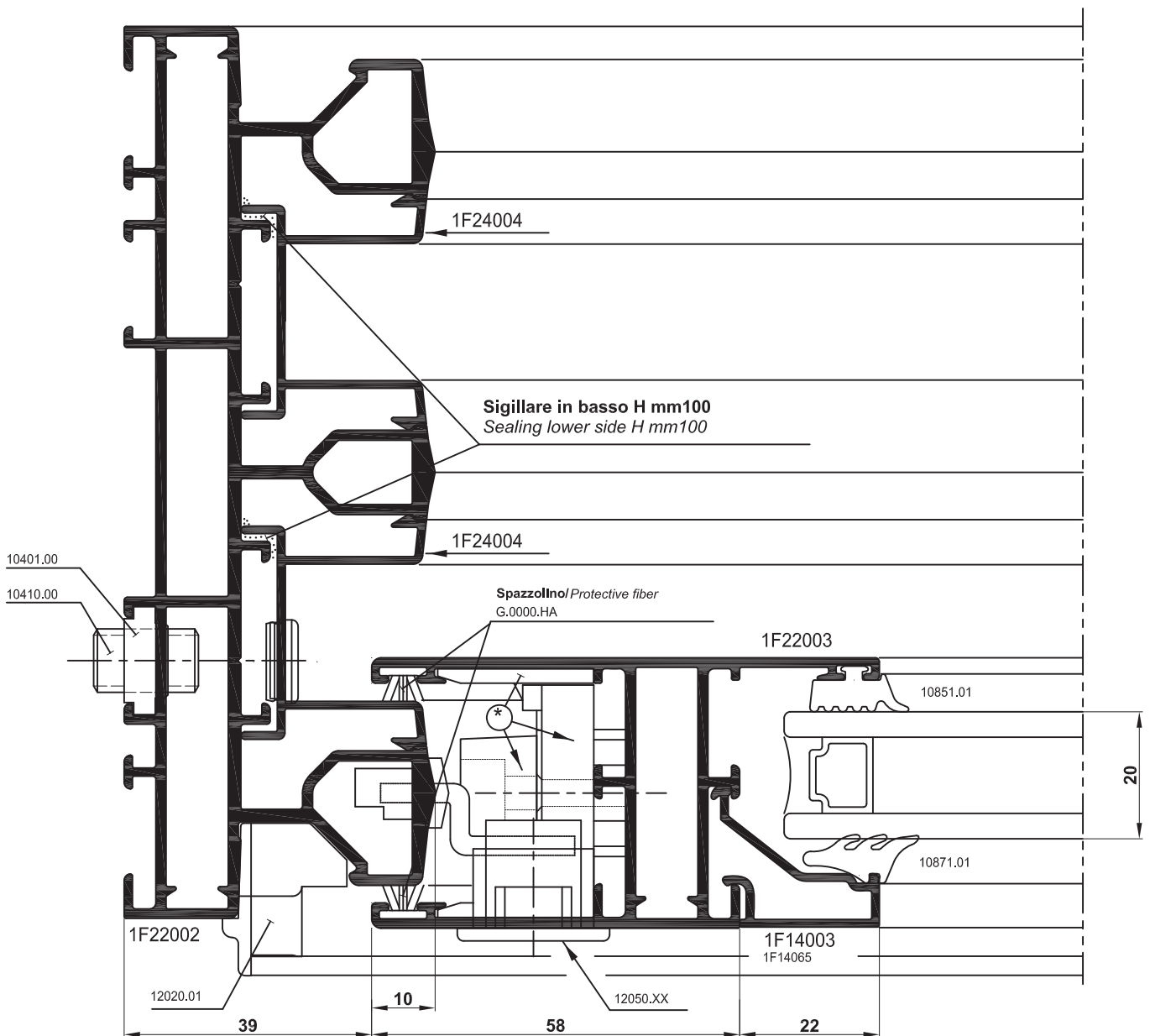

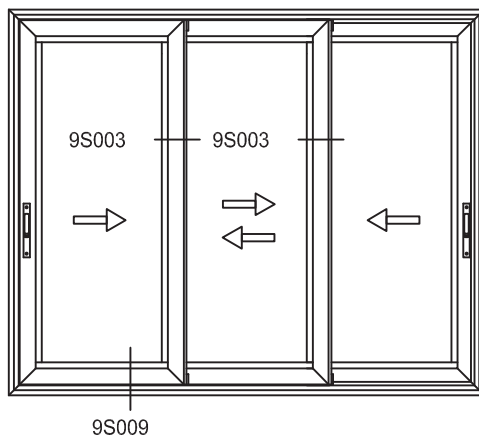

SEZ. 9S009

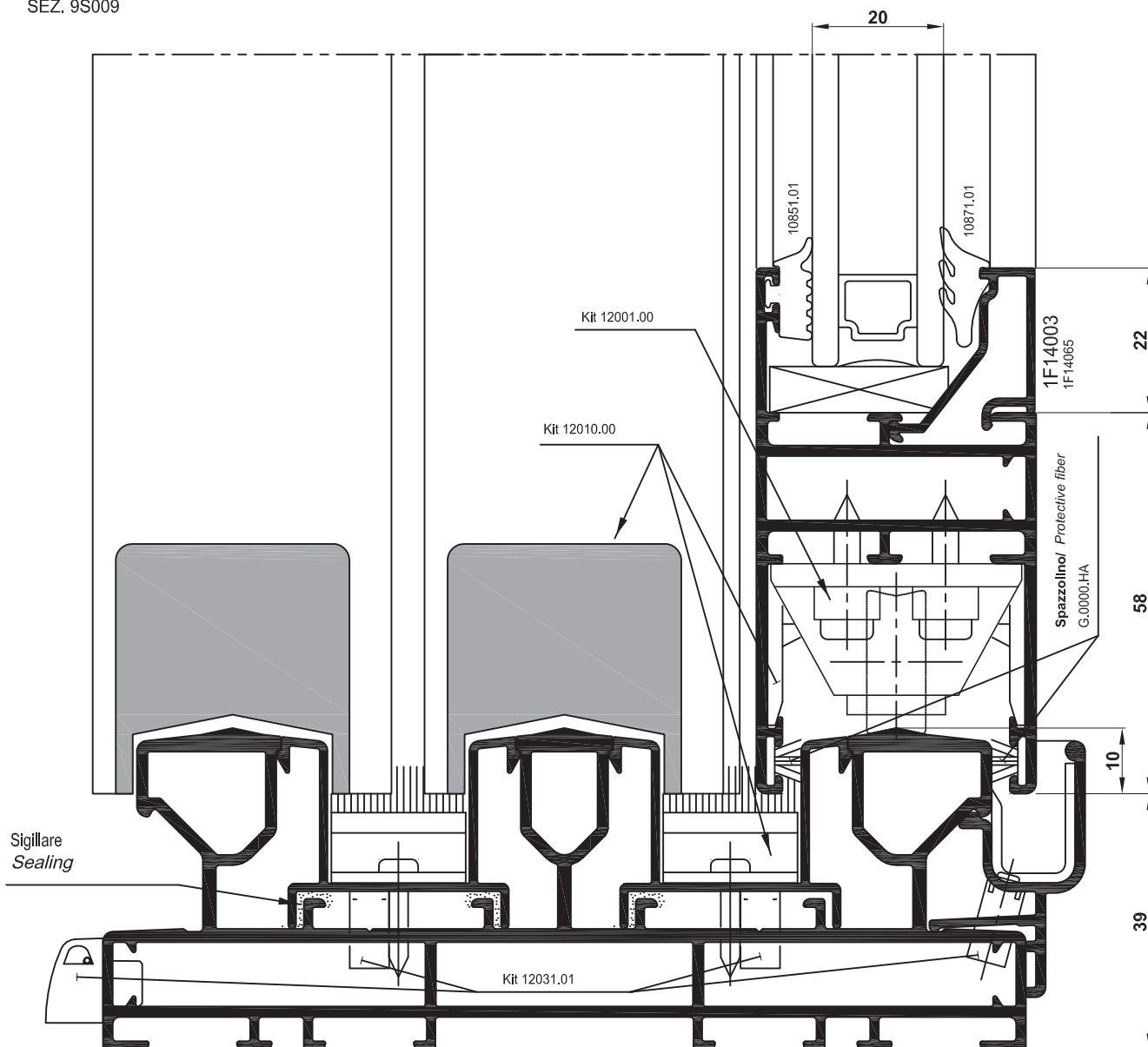

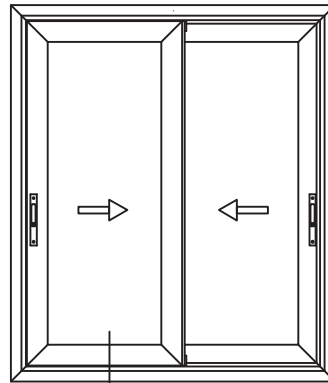

9S010

SEZ. 9S010

* Kit 12010.00

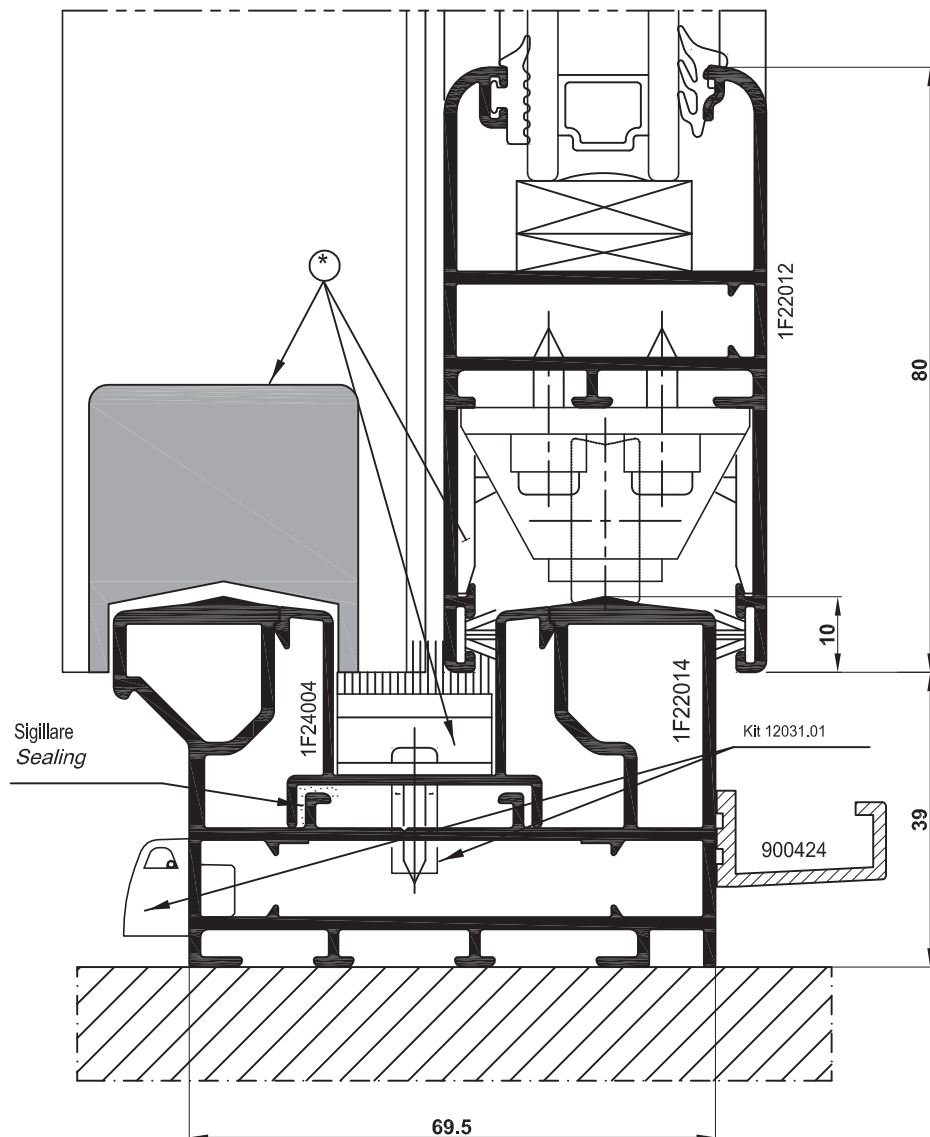

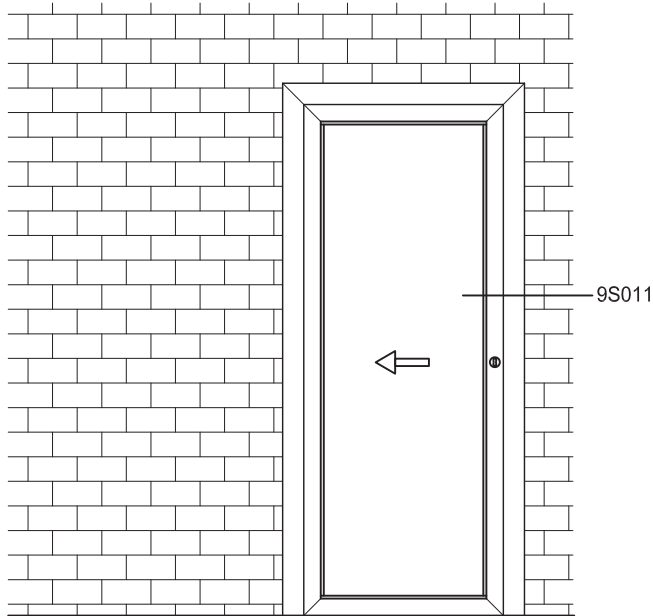

SEZ. 9S011

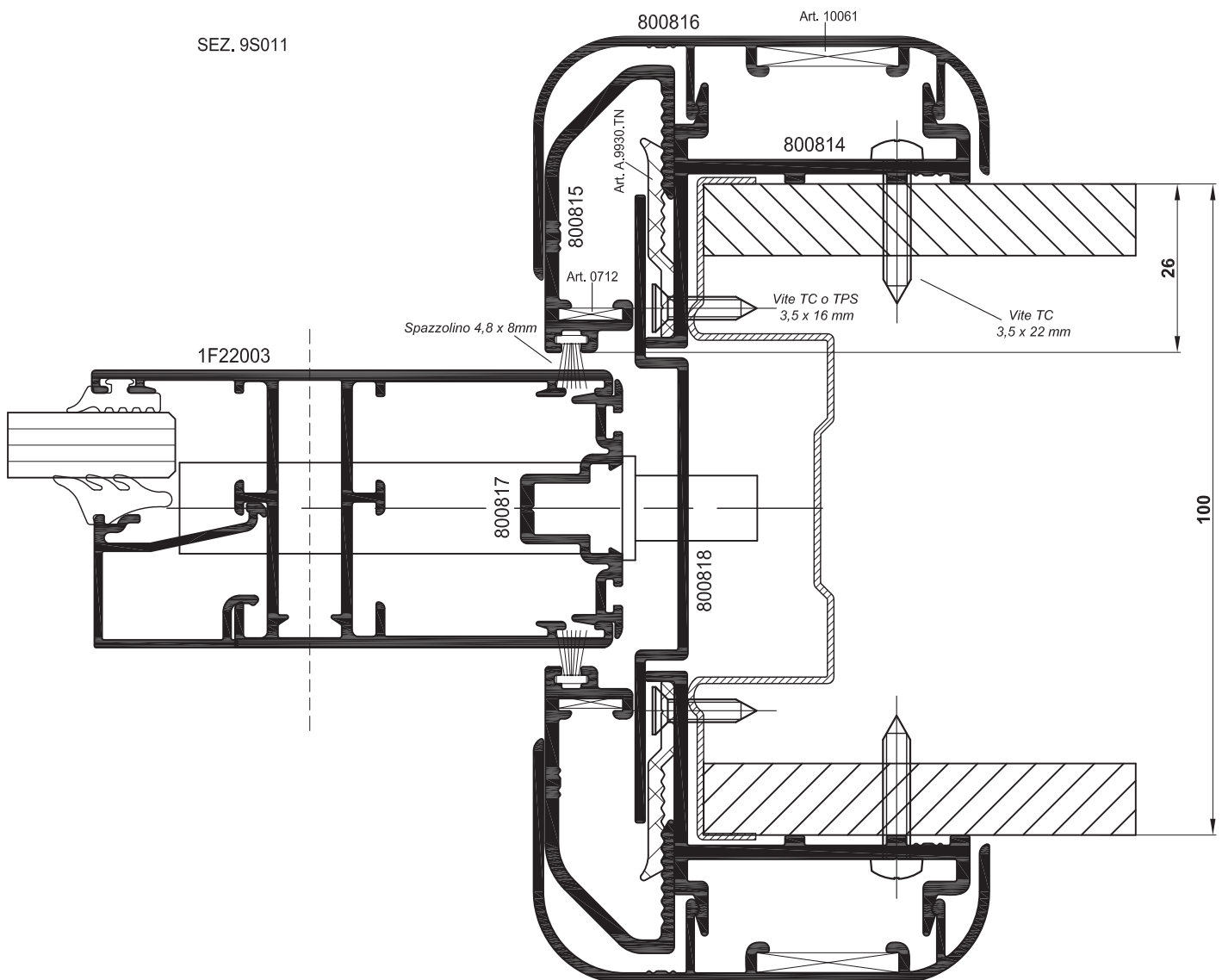

DISTINTE DI TAGLIO

CUT LIST

N.B: - Le dimensioni di taglio e di lavorazione indicate nelle pagine seguenti sono state ottenute considerando le quote teoriche.
 Pertanto è necessario verificare sempre le dimensioni del profilati prima di effettuare i tagli.
 Sapa declina ogni responsabilità per errori dovuti al mancato controllo da parte del costruttore.

SEZ. B-B



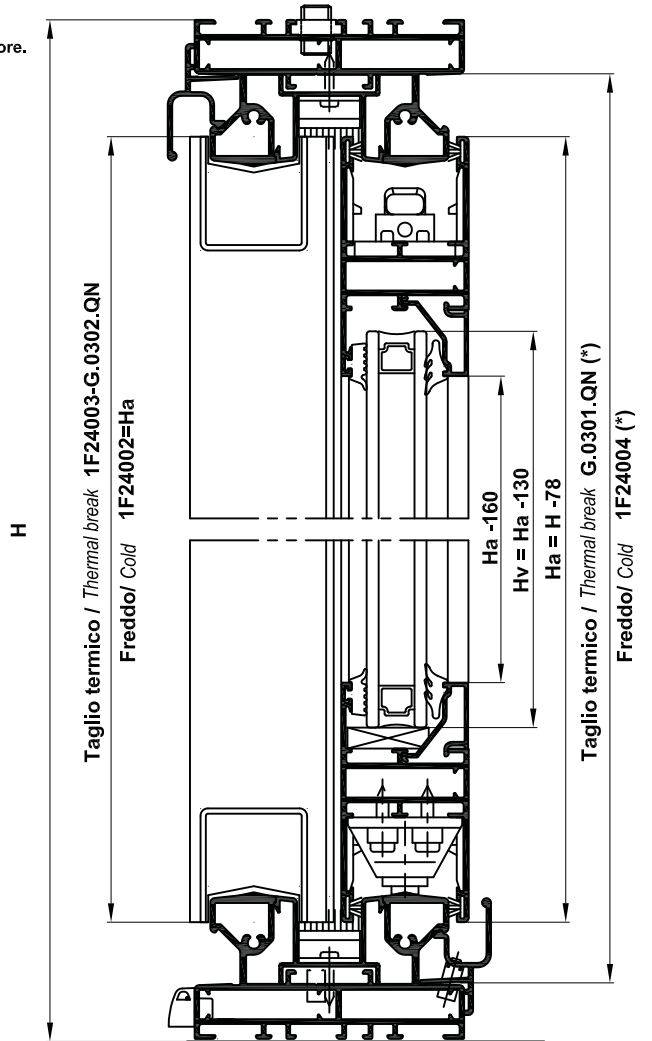
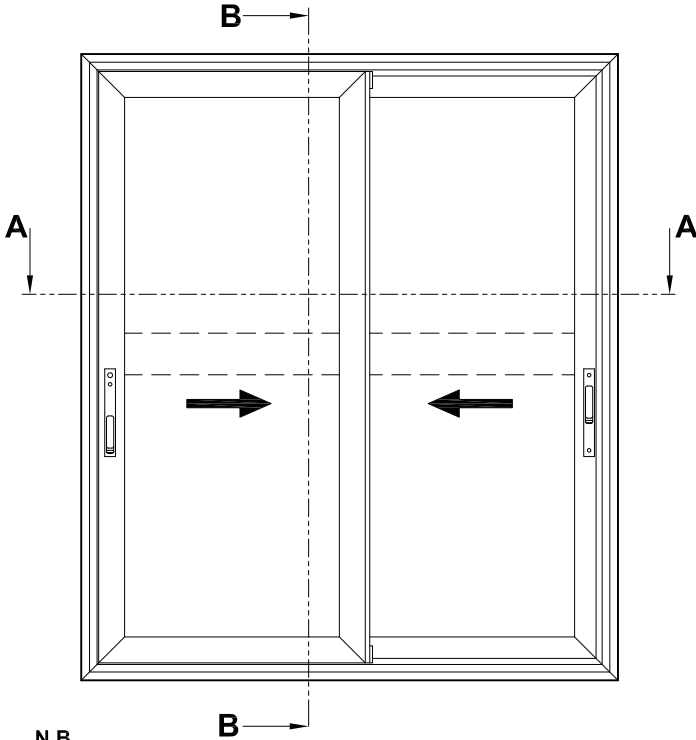





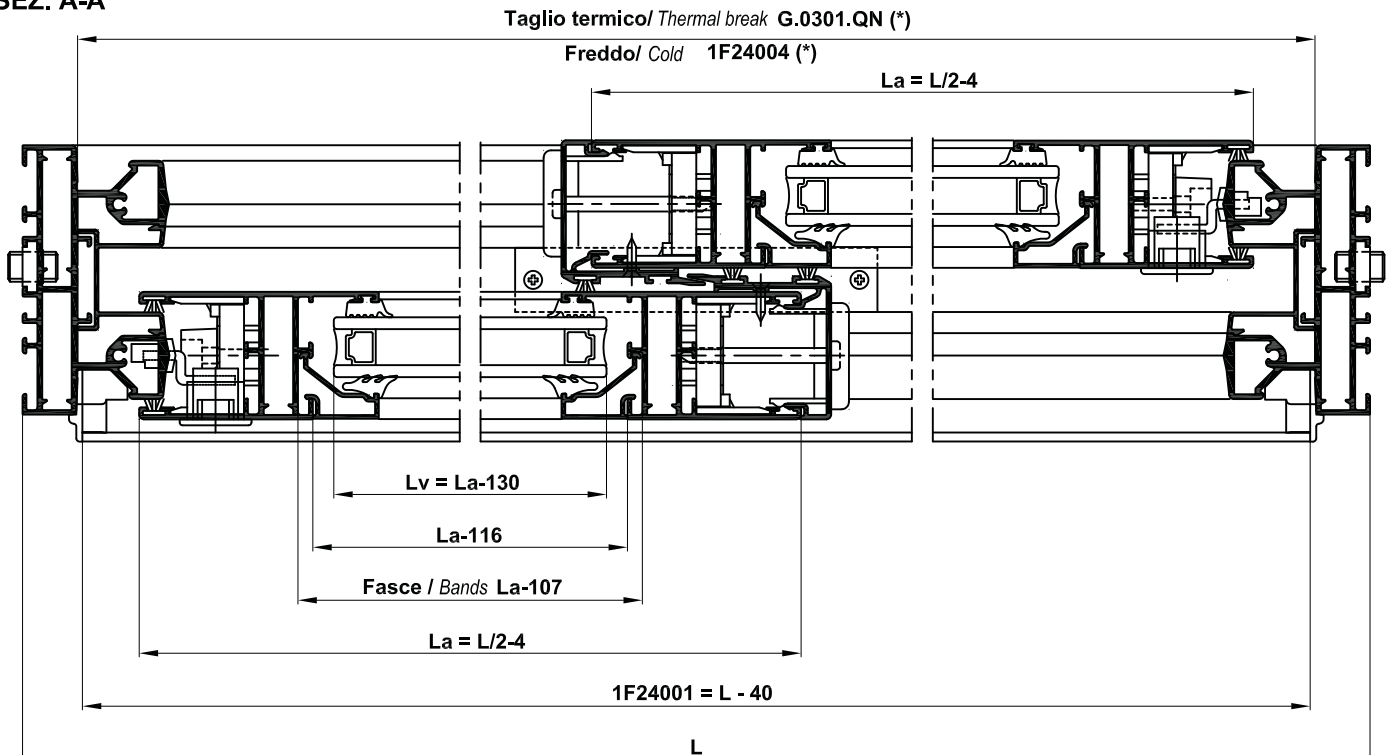

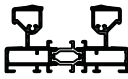
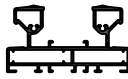

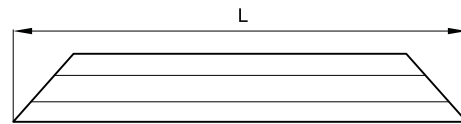
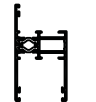
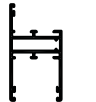
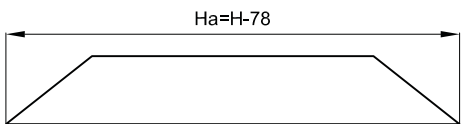
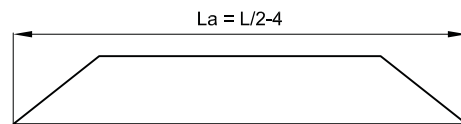
N.B: - The cutting and processing dimensions, indicated in the following pages, are obtained considering theoretical values.
 It is, therefore, always necessary to check the dimensions of the profiles before executing the cutting.
 Sapa declines any responsibility from errors caused from the missing dimensional check of the carpenter

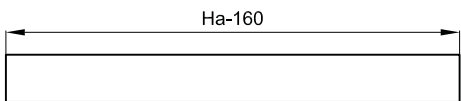
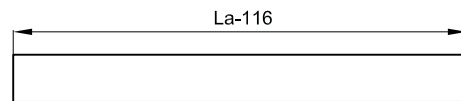

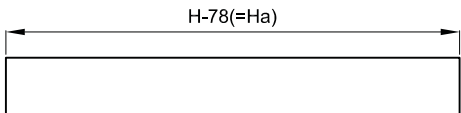
N.B.
Spessore vetro considerato 20mm
Gioco perimetrale tra profilato in alluminio e vetro 7mm
 For glass with 20mm thickness
 Space between glass and aluminium section 7mm
 (*) Si consiglia di tagliarlo accoppiato con il profilo telaio
 (*) It should be cut coupled with the frame section

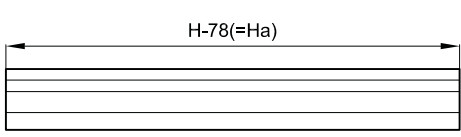
SEZ. A-A

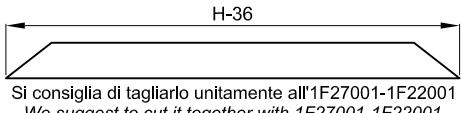
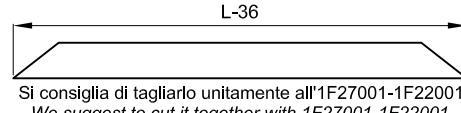

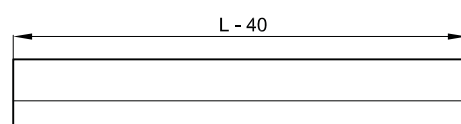
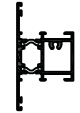
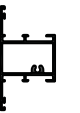
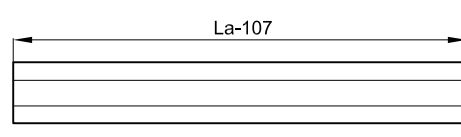
PROFILATO SECTION		N.Pz N.Pz	TAGLIO CUT	N.Pz N.Pz	TAGLIO CUT
WIN 90s ^{TT} SYSTEM	WIN 90s SYSTEM				
1F27001 	1F22001 	2		2	
1F27003 	1F22003 	4		4	
1F14003 	1F14003 	4		4	
1F24003 	1F24002 	2			
G.0302.QN 		2			
G.0301.QN 	1F24004 	2	 Si consiglia di tagliarlo unitamente all'1F27001-1F22001 We suggest to cut it together with 1F27001-1F22001	2	 Si consiglia di tagliarlo unitamente all'1F27001-1F22001 We suggest to cut it together with 1F27001-1F22001
1F24001 	1F24001 			2	
1F27005 	1F22005 			2	

ACCESSORI WIN90TT / FREDDO
ACCESSORIES WIN90TT / COLD

ARTICOLO ITEM	DESCRIZIONE DESCRIPTION	N.	ARTICOLO ITEM	DESCRIZIONE DESCRIPTION	N.	ARTICOLO ITEM	DESCRIZIONE DESCRIPTION	N.
10040.01	Squadretta allineamento aletta Alignment corner joint on fin	8	10510.01	Base tassello spessoramento vetro 5mm Glass registration dolly block 5mm	8			
10029.00	Squadretta ad avvitare (telajo - anta) Corner joint to be screwed (frame - leafs)	16	10511.01	Spessore regolazione vetro 2mm Glass registration spacer 2mm	8			
10026.00	Squadretta ad avvitare (telajo - anta TT) Corner joint to be screwed (TT frame - leafs)	16	12020.01	Tappi per gocciolatoio e raccoglicondensa (coppia) Drip channel and drip condensation plugs (pair)	2			
12001.00	Kit 4 carrelli regolabili 4 adjustable double rollers kit	1	12031.01	Kit valvola scarico acqua Water drain valve kit	1			
12010.00	Kit tappi per 2 ante Plug kit for 2 wings	1	12070.00	Kit aggancio chiusura ad incasso Recessed clip-on locking kit	2			
10403.00	Basetta per regolo mobile In alluminio Aluminium plate for adjustable fixing	8	12201.xx	Maniglia interna ad incasso Insert internal handle for locking	2			
10410.00	Grano per regolo mobile Dowel for adjustable fixing	8	12071.00	Blocchetti di fissaggio maniglia e rinforzo aletta Fixing and building blocks for locking on fin	2			
10535.01	Tappo copriforo Ø 12mm Hole plug Ø 12mm	8						

GUARNIZIONI
WEATHERSTRIPS

ARTICOLO ITEM	DESCRIZIONE DESCRIPTION	N.	ARTICOLO ITEM	DESCRIZIONE DESCRIPTION	N.	ARTICOLO ITEM	DESCRIZIONE DESCRIPTION	N.
10851.01	Guarnizione esterna vetro External weatherstrips on glass	4H - 2L	G.0000.HA	Guarnizione a spazzolino Protective fiber	8H - 4L			
10871.01	Guarnizione interna vetro Internal weatherstrips on glass	4H - 2L						

N.B. - Le dimensioni di taglio e di lavorazione indicate nelle pagine seguenti sono state ottenute considerando le quote teoriche.
 Pertanto è necessario verificare sempre le dimensioni dei profilati prima di effettuare i tagli.
 Sapa declina ogni responsabilità per errori dovuti al mancato controllo da parte del costruttore.

SEZ. B-B

N.B. - The cutting and processing dimensions, indicated in the following pages, are obtained considering theoretical values.
 It is, therefore, always necessary to check the dimensions of the profiles before executing the cutting.
 Sapa declines any responsibility from errors caused from the missing dimensional check of the carpenter

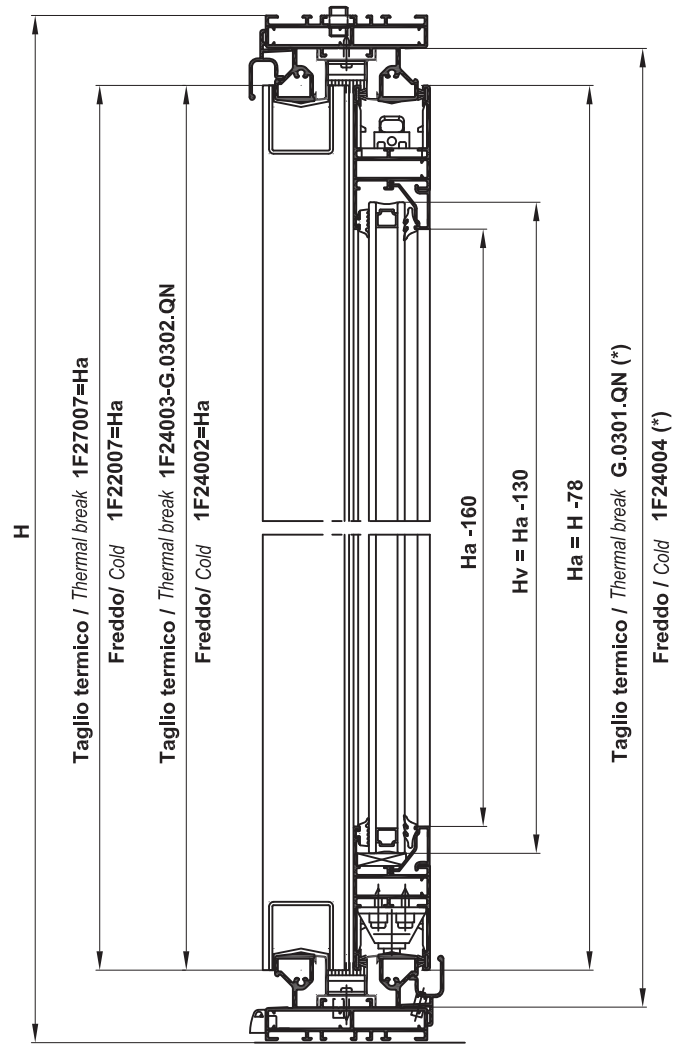
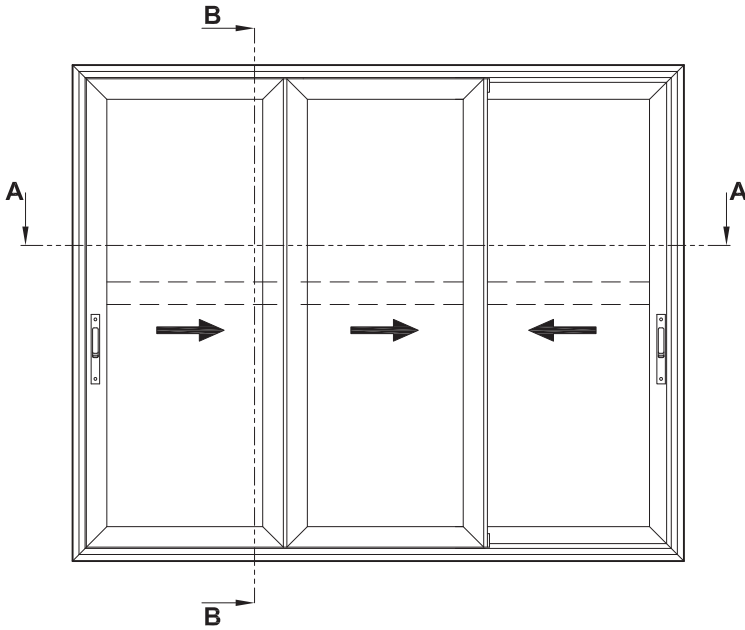







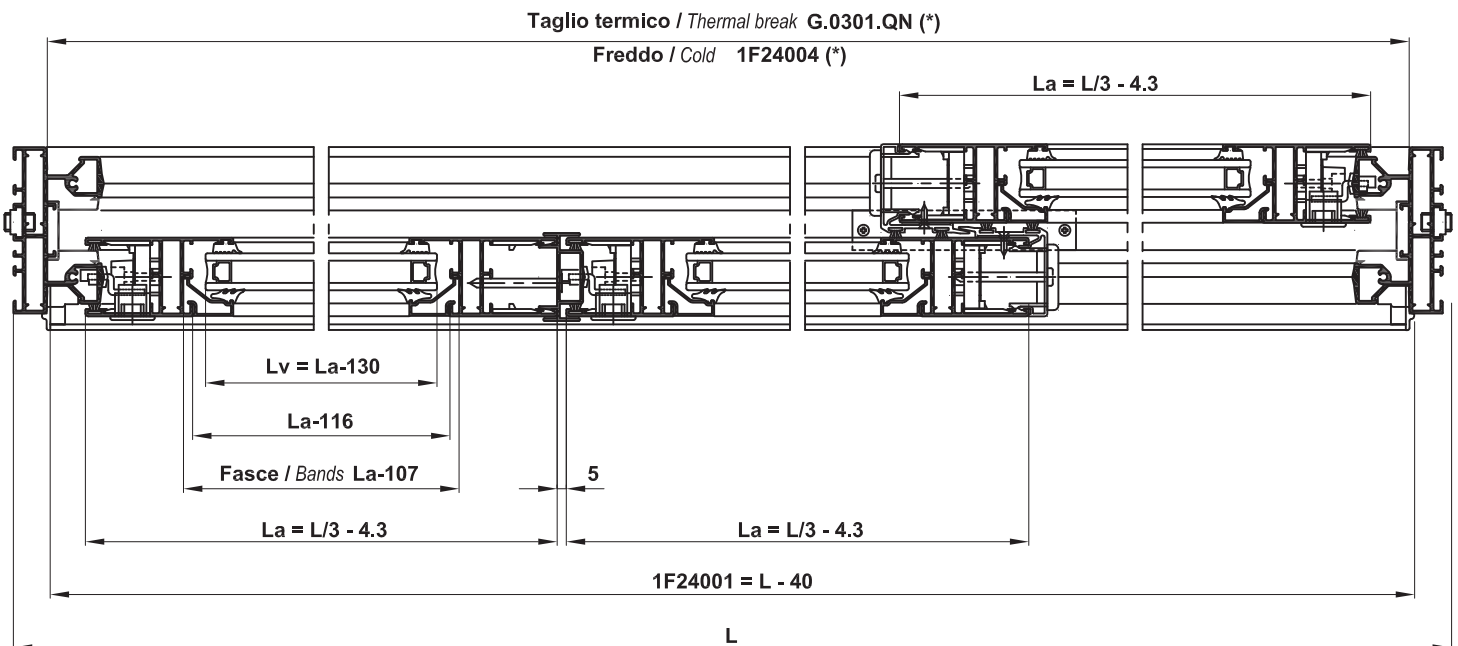

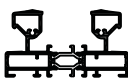
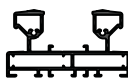

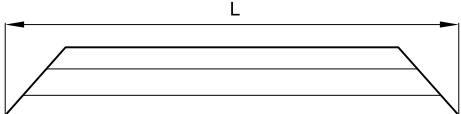
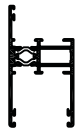
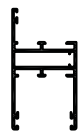
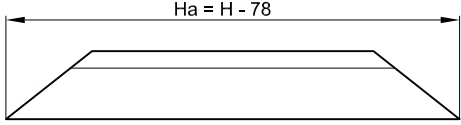
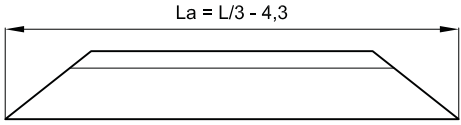

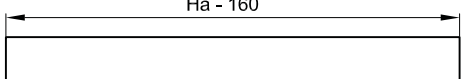
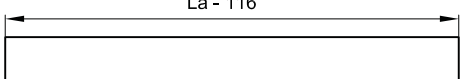

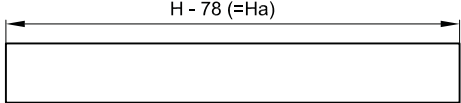
N.B.
 Spessore vetro considerato 20mm
 Gioco perimetrale tra profilato in alluminio e vetro 7mm
 For glass with 20mm thickness
 Space between glass and aluminium section 7mm

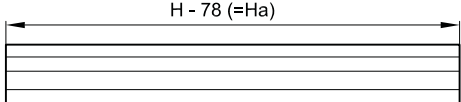
(*) Si consiglia di tagliarlo accoppiato con il profilo telaio
 (*) It should be cut coupled with the frame section

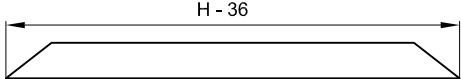
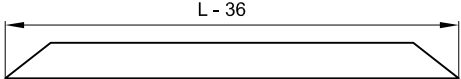
SEZ. A-A

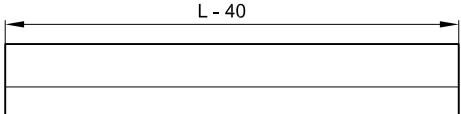

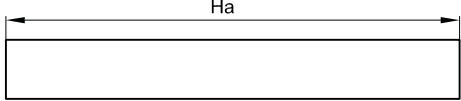
PROFILATO SECTION	N.Pz N.Pz	TAGLIO CUT	N.Pz N.Pz	TAGLIO CUT
WIN ^{90s} SYSTEM WIN ^{90s} SYSTEM				
1F27001 	1F22001 	2 	2	
1F27003 	1F22003 	6 	6	
1F14003 	1F14003 	6 	6	
1F24003 	1F24002 	2 		
G.0302.QN 		2 		
G.0301.QN 	1F24004 	2  Si consiglia di tagliarlo unitamente all'1F27001 - 1F22001 We suggest to cut it together with 1F27001 - 1F22001	2	 Si consiglia di tagliarlo unitamente all'1F27001 - 1F22001 We suggest to cut it together with 1F27001 - 1F22001
1F24001 	1F24001 		2	
1F27007 	1F22007 	1 		

ACCESSORI WIN90TT / FREDDO
ACCESSORIES WIN90TT / COLD

ARTICOLO ITEM	DESCRIZIONE DESCRIPTION	N.	ARTICOLO ITEM	DESCRIZIONE DESCRIPTION	N.	ARTICOLO ITEM	DESCRIZIONE DESCRIPTION	N.
10040.01	Squadretta allineamento aletta Alignment corner joint on fin	12	10510.01	Base tassello spessoramento vetro 5mm Glass registration dolly block 5mm	12			
10029.00	Squadretta ad avvitare (telajo - anta) Corner joint to be screwed (frame - leafs)	20	10511.01	Spessore regolazione vetro 2mm Glass registration spacer 2mm	12			
10026.00	Squadretta ad avvitare (telajo - anta TT) Corner joint to be screwed (TT frame - leafs)	20	12020.01	Tappi per gocciolatoio e raccoglicondensa (coppia) Drip channel and drip condensation plugs (pair)	2			
12001.00	Kit 4 carrelli regolabili 4 adjustable double rollers kit	2	12031.01	Kit valvola scarico acqua Water drain valve kit	2			
12010.00	Kit tappi per 2 ante Plug kit for 2 wings	2	12070.00	Kit aggancio chiusura ad incasso Recessed clip-on locking kit	3			
10403.00	Basetta per regolo mobile In alluminio Aluminium plate for adjustable fixing	8	12201.xx	Maniglia interna ad incasso Insert internal handle for locking	3			
10410.00	Grano per regolo mobile Dowel for adjustable fixing	8	12071.00	Blocchetti di fissaggio maniglia e rinforzo aletta Fixing and building blocks for locking on fin	3			
10535.01	Tappo copriforo Ø 12mm Hole plug Ø 12mm	8	12027.00	Piastrina antisollevamento 3° anta 3th door non-lifting plate	1			

GUARNIZIONI
WEATHERSTRIPS

ARTICOLO ITEM	DESCRIZIONE DESCRIPTION	N.	ARTICOLO ITEM	DESCRIZIONE DESCRIPTION	N.	ARTICOLO ITEM	DESCRIZIONE DESCRIPTION	N.
10851.01	Guarnizione esterna vetro External weatherstrips on glass	6H - 2L	G.0000.HA	Guarnizione a spazzolino Protective fiber	10H - 4L			
10871.01	Guarnizione interna vetro Internal weatherstrips on glass	6H - 2L						

N.B: - Le dimensioni di taglio e di lavorazione indicate nelle pagine seguenti sono state ottenute considerando le quote teoriche.
 Pertanto è necessario verificare sempre le dimensioni del profilato prima di effettuare i tagli.
 Sapa declina ogni responsabilità per errori dovuti al mancato controllo da parte del costruttore.

SEZ. B-B



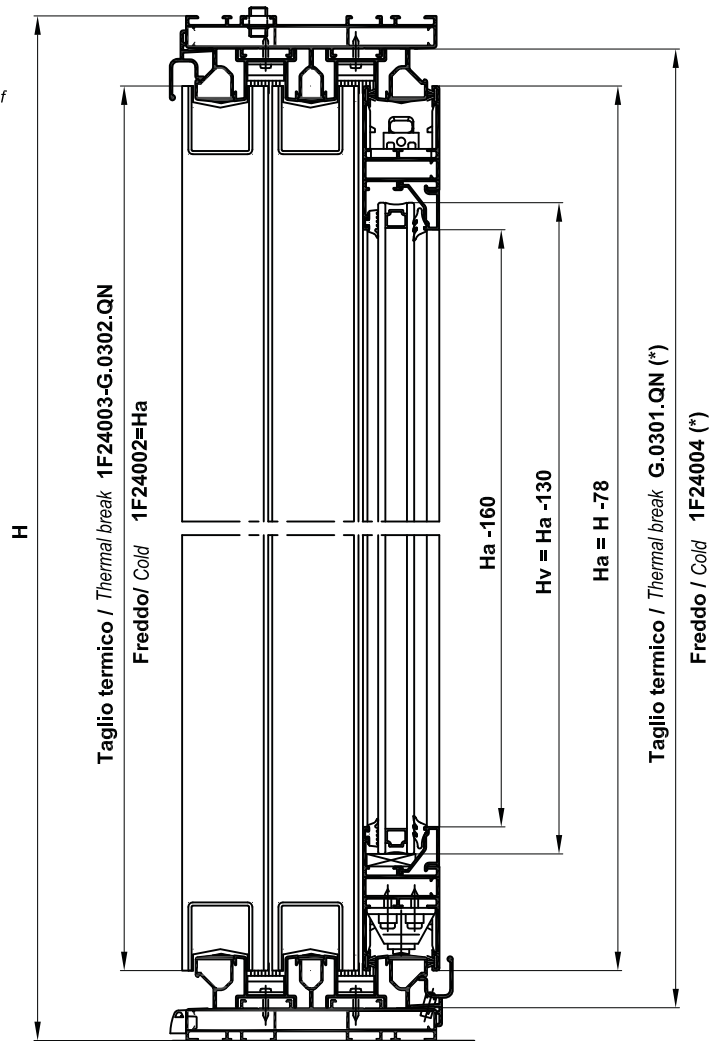
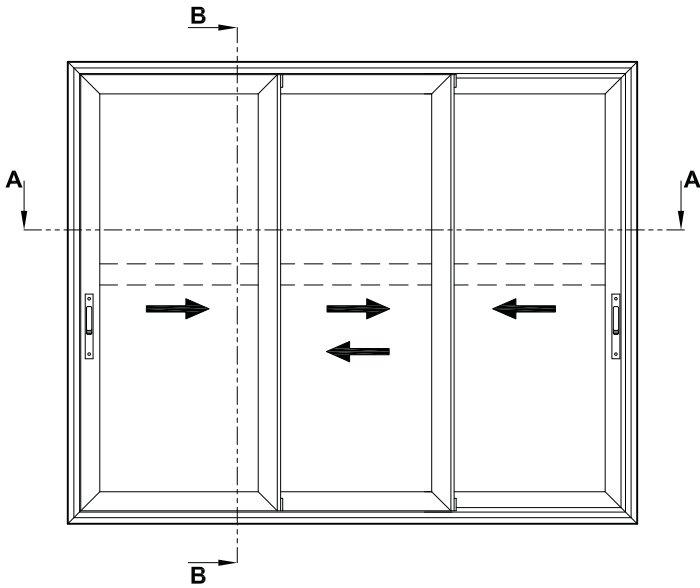





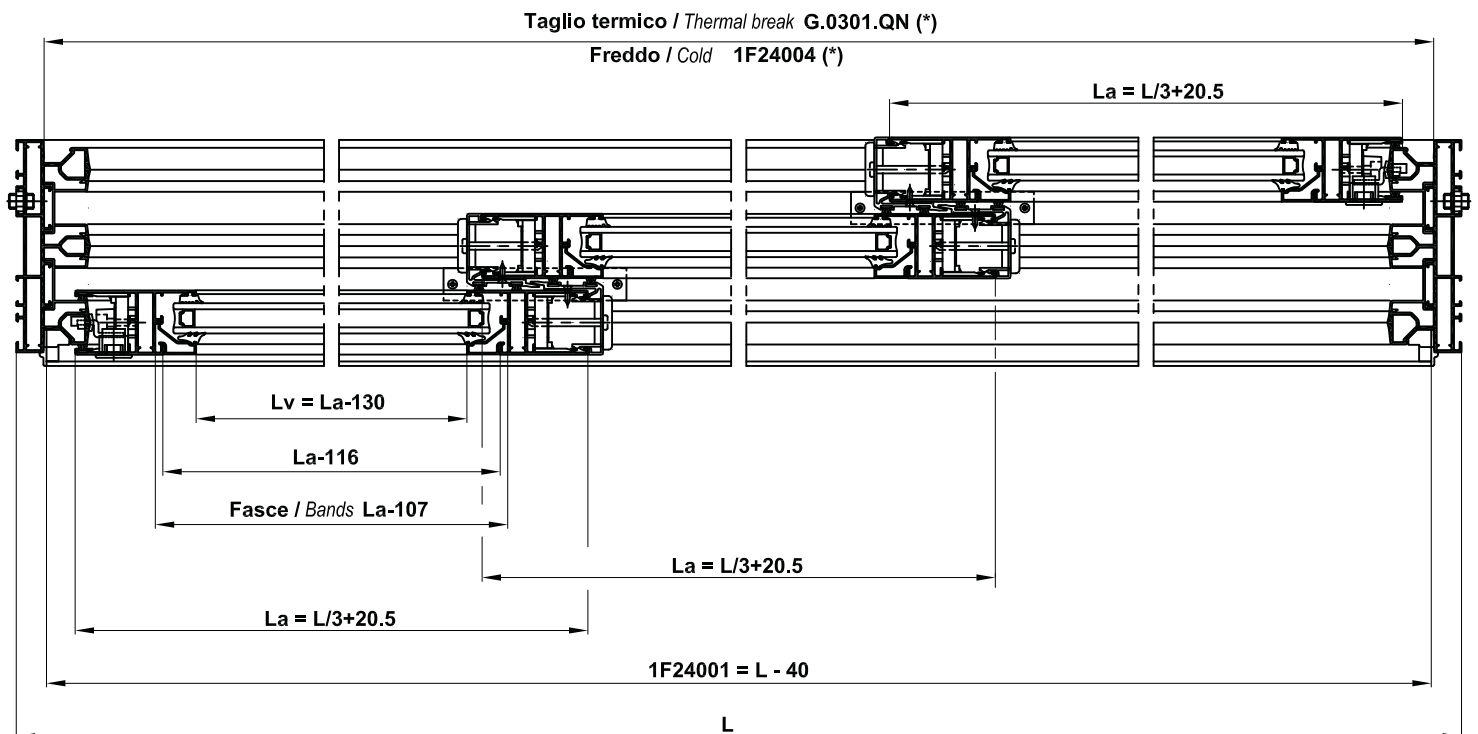



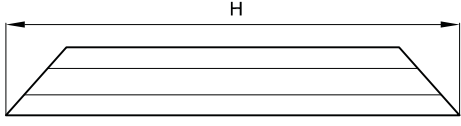
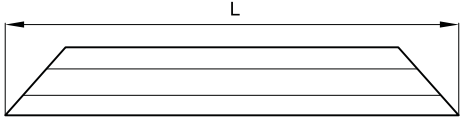
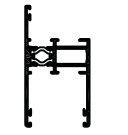
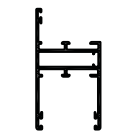
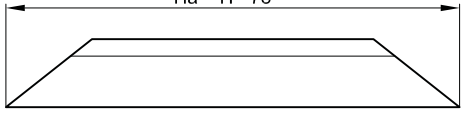
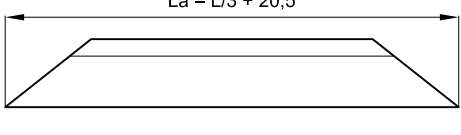

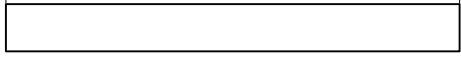
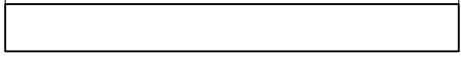
N.B: - The cutting and processing dimensions, indicated in the following pages, are obtained considering theoretical values.
 It is, therefore, always necessary to check the dimensions of the profiles before executing the cutting.
 Sapa declines any responsibility from errors caused from the missing dimensional check of the carpenter

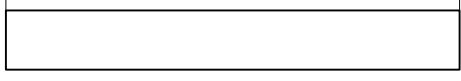

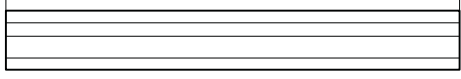
N.B.
Spessore vetro considerato 20mm
Gioco perimetrale tra profilato in alluminio e vetro 7mm
For glass with 20mm thickness
Space between glass and aluminium section 7mm
 (*) Si consiglia di tagliarlo accoppiato con il profilo telaio
 (*) It should be cut coupled with the frame section

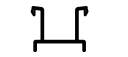
SEZ. A-A

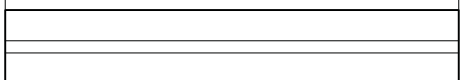
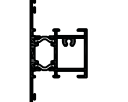
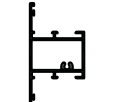
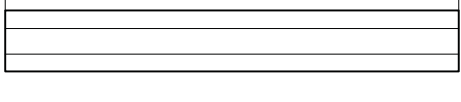

PROFILATO SECTION	N.Pz N.Pz	TAGLIO CUT	N.Pz N.Pz	TAGLIO CUT
 1F27002	 1F22002		2	
 1F27003	 1F22003		6	
 1F14003	 1F14003		6	
 1F24003	 1F24002		4	
 G.0302.QN			4	
 1F24001	 1F24001	 <p>Si consiglia di tagliarlo unitamente all'1F27002 - 1F22002 We suggest to cut it together with 1F27002 - 1F22002</p>	4	 <p>Si consiglia di tagliarlo unitamente all'1F27002 - 1F22002 We suggest to cut it together with 1F27002 - 1F22002</p>
 1F24001	 1F24001		2	
 1F27005	 1F22005		3	

ACCESSORI WIN90TT / FREDDO
ACCESSORIES WIN90TT / COLD

ARTICOLO ITEM	DESCRIZIONE DESCRIPTION	N.	ARTICOLO ITEM	DESCRIZIONE DESCRIPTION	N.	ARTICOLO ITEM	DESCRIZIONE DESCRIPTION	N.
10040.01	Squadretta allineamento aletta Alignment corner joint on fin	12	10535.01	Tappo copriforo Ø 12mm Hole plug Ø 12mm	8			
10029.00	Squadretta ad avvitare (telaio) Corner joint to be screwed (frame)	8	10510.01	Base tassello spessoramento vetro 5mm Glass registration dolly block 5mm	12			
10026.00	Squadretta ad avvitare (anta) Corner joint to be screwed (TT frame - leafs)	12	10511.01	Spessore regolazione vetro 2mm Glass registration spacer 2mm	12			
10026.00	Squadretta ad avvitare (telaio - anta TT) Corner joint to be screwed (TT frame - leafs)	20	12020.01	Tappi per gocciolatoio e raccoglicondensa (coppia) Drip channel and drip condensation plugs (pair)	2			
12001.00	Kit 4 carrelli regolabili 4 adjustable double rollers kit	2	12031.01	Kit valvola scarico acqua Water drain valve kit	3			
12010.00	Kit tappi per 2 ante Plug kit for 2 wings	2	12070.00	Kit aggancio chiusura ad incasso Recessed clip-on locking kit	2			
10403.00	Basetta per regolo mobile in alluminio Dowel for adjustable fixing	8	12201.xx	Maniglia interna ad incasso Insert internal handle for locking	2			
10410.00	Grano per regolo mobile Aluminium plate for adjustable fixing	8	12071.00	Blocchetti di fissaggio maniglia e rinforzo aletta Fixing and building blocks for locking on fin	2			

GUARNIZIONI
WEATHERSTRIPS

ARTICOLO ITEM	DESCRIZIONE DESCRIPTION	N.	ARTICOLO ITEM	DESCRIZIONE DESCRIPTION	N.	ARTICOLO ITEM	DESCRIZIONE DESCRIPTION	N.
10851.01	Guarnizione esterna vetro External weatherstrips on glass	6H - 2L	G.0000.HA	Guarnizione a spazzolino Protective fiber	12H - 4L			
10871.01	Guarnizione interna vetro Internal weatherstrips on glass	6H - 2L						

N.B: - Le dimensioni di taglio e di lavorazione indicate nelle pagine seguenti sono state ottenute considerando le quote teoriche.
 Pertanto è necessario verificare sempre le dimensioni del profilato prima di effettuare i tagli.
 Sapa declina ogni responsabilità per errori dovuti al mancato controllo da parte del costruttore.

N.B: - The cutting and processing dimensions, indicated in the following pages, are obtained considering theoretical values.
 It is, therefore, always necessary to check the dimensions of the profiles before executing the cutting.
 Sapa declines any responsibility from errors caused from the missing dimensional check of the carpenter

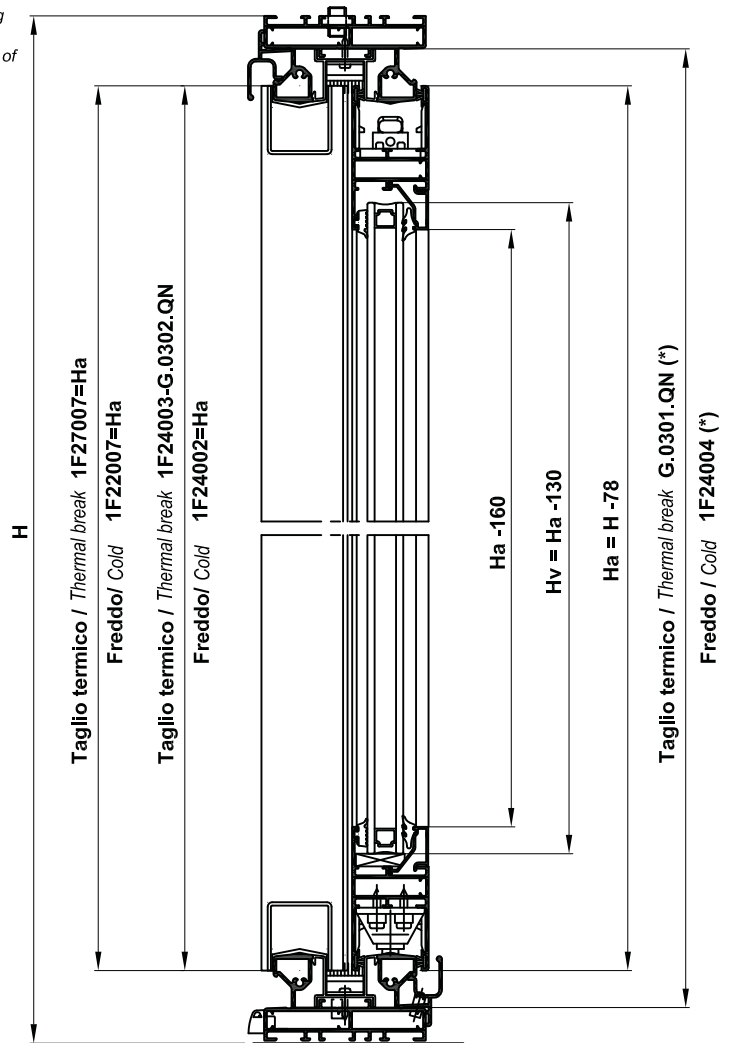
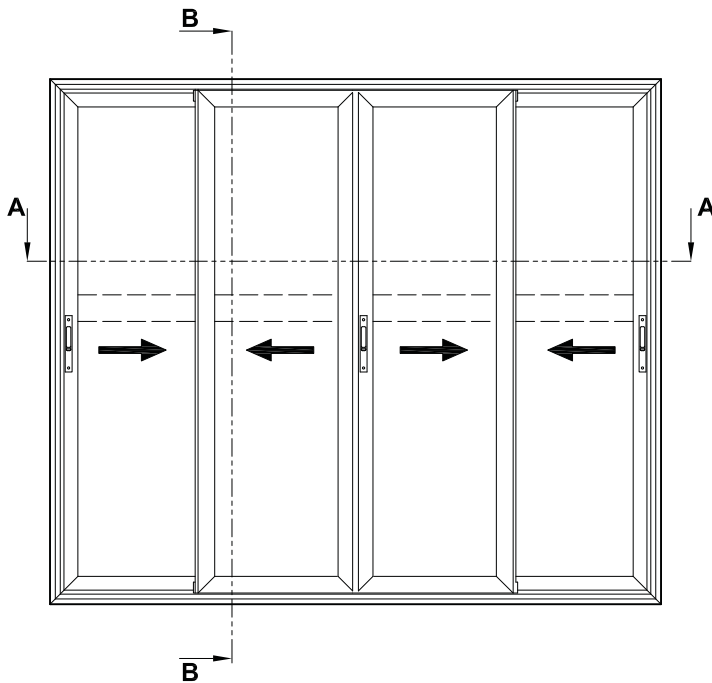









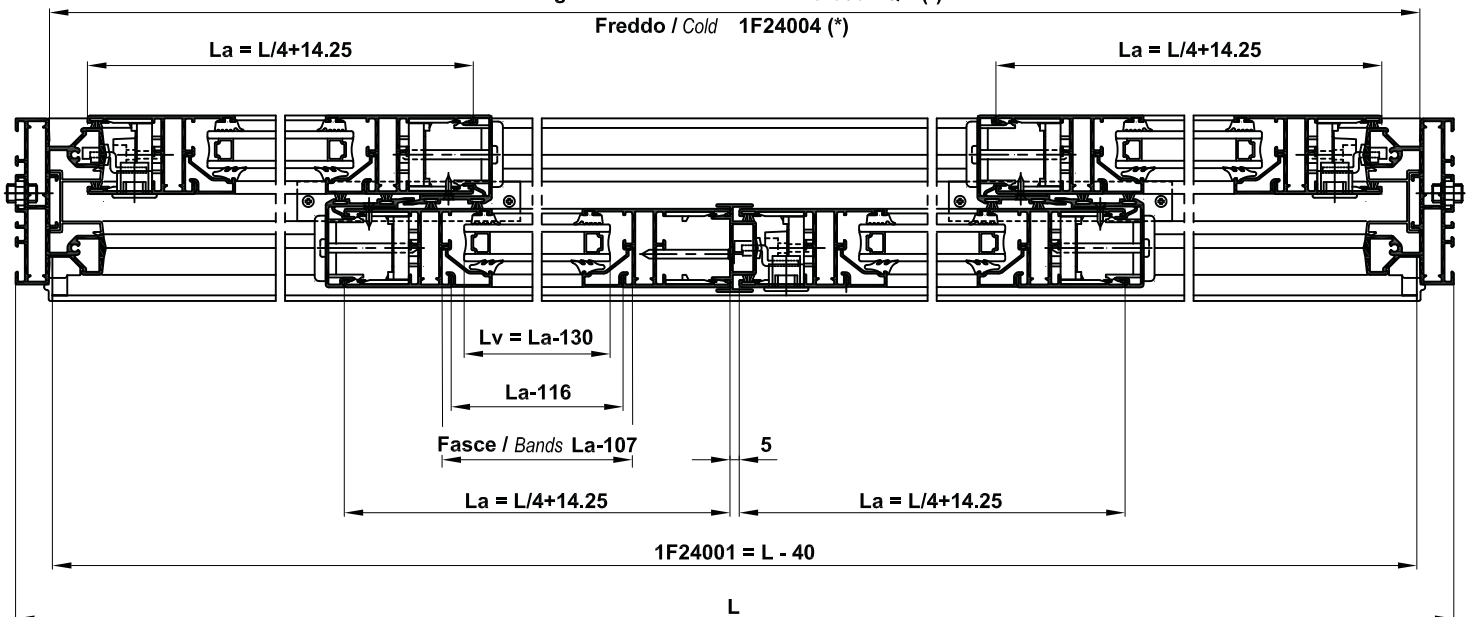





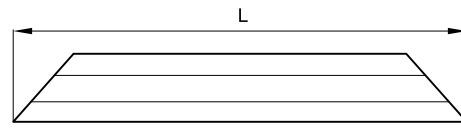
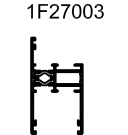
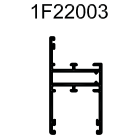
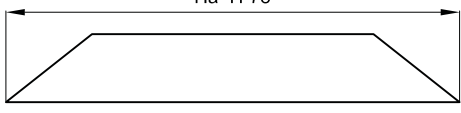
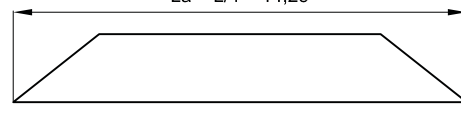

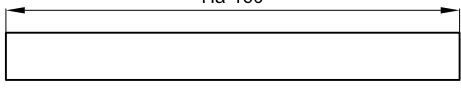
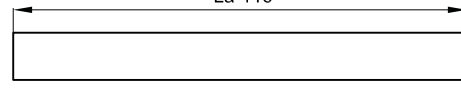
N.B.
 Spessore vetro considerato 20mm
 Gioco perimetrale tra profilato in alluminio e vetro 7mm
 For glass with 20mm thickness
 Space between glass and aluminium section 7mm

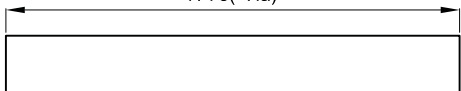
(*) Si consiglia di tagliarlo accoppiato con il profilo telaio
 (*) It should be cut coupled with the frame section

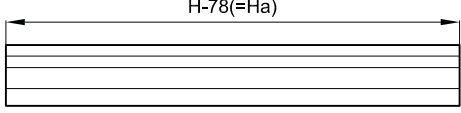
SEZ. A-A

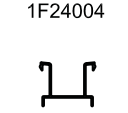
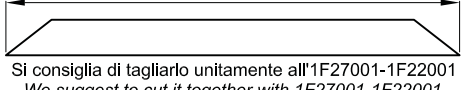
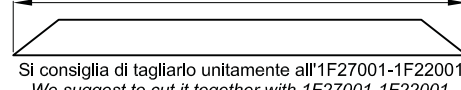
Taglio termico / Thermal break G.0301.QN (*)
Freddo / Cold 1F24004 (*)

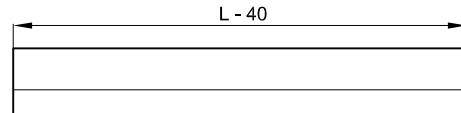

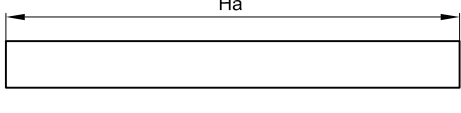
PROFILATO SECTION		N.Pz N.Pz	TAGLIO CUT	N.Pz N.Pz	TAGLIO CUT
		2		2	
		8		8	
		8		8	
		4			
		4			
		2	 Si consiglia di tagliarlo unitamente all'1F27001-1F22001 We suggest to cut it together with 1F27001-1F22001	2	 Si consiglia di tagliarlo unitamente all'1F27001-1F22001 We suggest to cut it together with 1F27001-1F22001
				2	
		1			

ACCESSORI WIN90TT / FREDDO
ACCESSORIES WIN90TT / COLD

ARTICOLO ITEM	DESCRIZIONE DESCRIPTION	N.	ARTICOLO ITEM	DESCRIZIONE DESCRIPTION	N.	ARTICOLO ITEM	DESCRIZIONE DESCRIPTION	N.
10040.01	Squadretta allineamento aletta Alignment corner joint on fin	16	10510.01	Base tassello spessoramento vetro 5mm Glass registration dolly block 5mm	16			
10029.00	Squadretta ad avvitare (telajo - anta) Corner joint to be screwed (frame - leafs)	24	10511.01	Spessore regolazione vetro 2mm Glass registration spacer 2mm	16			
10026.00	Squadretta ad avvitare (telajo - anta TT) Corner joint to be screwed (TT frame - leafs)	24	12020.01	Tappi per gocciolatoio e raccoglicondensa (coppia) Drip channel and drip condensation plugs (pair)	2			
12001.00	Kit 4 carrelli regolabili 4 adjustable double rollers kit	2	12031.01	Kit valvola scarico acqua Water drain valve kit	2			
12010.00	Kit tappi per 2 ante Plug kit for 2 wings	2	12070.00	Kit aggancio chiusura ad incasso Recessed clip-on locking kit	3			
10403.00	Basetta per regolo mobile In alluminio Aluminium plate for adjustable fixing	10	12201.xx	Maniglia interna ad incasso Insert internal handle for locking	3			
10410.00	Grano per regolo mobile Dowel for adjustable fixing	10	12071.00	Blocchetti di fissaggio maniglia e rinforzo aletta Fixing and building blocks for locking on fin	3			
10535.01	Tappo copriforo Ø 12mm Hole plug Ø 12mm	10	12027.00	Piastrina antisollevamento 4ª anta 4th door non-lifting plate	1			

GUARNIZIONI
WEATHERSTRIPS

ARTICOLO ITEM	DESCRIZIONE DESCRIPTION	N.	ARTICOLO ITEM	DESCRIZIONE DESCRIPTION	N.	ARTICOLO ITEM	DESCRIZIONE DESCRIPTION	N.
10851.01	Guarnizione esterna vetro External weatherstrips on glass	8H - 2L	G.0000.HA	Guarnizione a spazzolino Protective fiber	14H - 4L			
10871.01	Guarnizione interna vetro Internal weatherstrips on glass	8H - 2L						

SQUADRETTE AD AVVITARE
CORNER JOINTS TO BE SCREWED

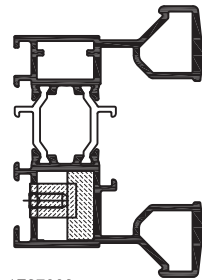
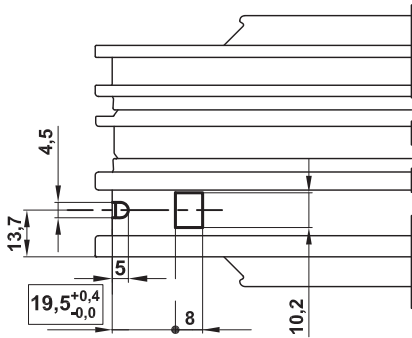

1F27008

WIN 90s^{TT}
SYSTEM

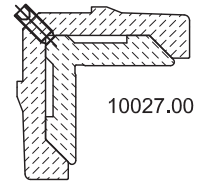

10027.00

Attrezzatura: PUNZONATRICE
Tooling: PUNCHING MACHINE

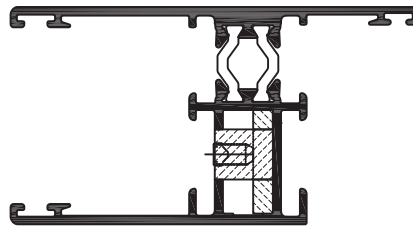
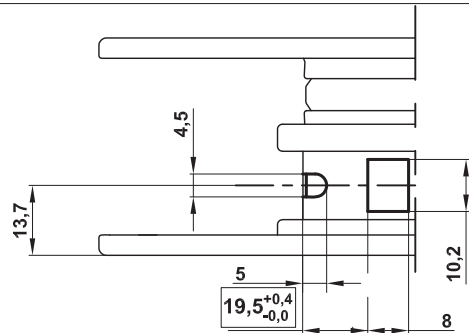

1F27003 / 1F27004 / 1F27009 / 1F27015

WIN 90s^{TT}
SYSTEM

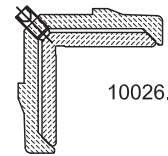

10026.00

Attrezzatura: PUNZONATRICE
Tooling: PUNCHING MACHINE

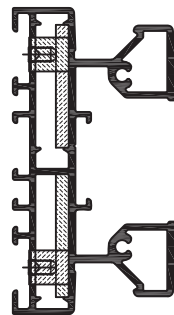
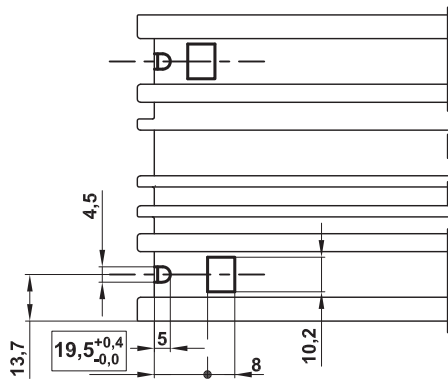

1F22001 / 1F22010

WIN 90s
SYSTEM

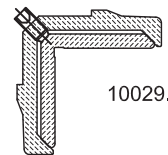

10029.00

Attrezzatura: PUNZONATRICE
Tooling: PUNCHING MACHINE

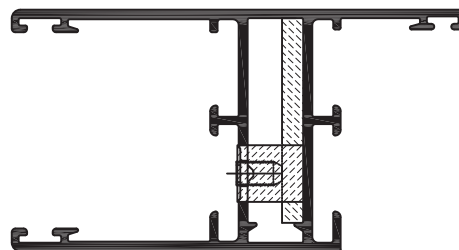
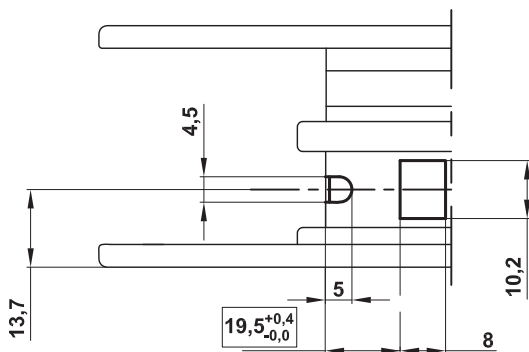

1F22003 / 1F22004 / 1F22012

WIN 90s
SYSTEM

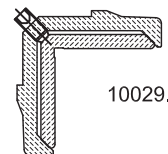

10029.00

Attrezzatura: PUNZONATRICE
Tooling: PUNCHING MACHINE

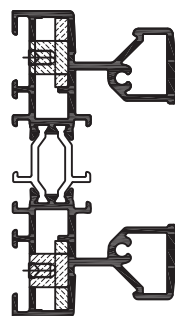
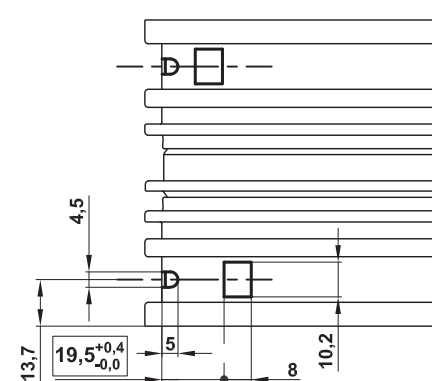

1F27001 / 1F27010 / 1F27014

WIN 90s^{TT}
SYSTEM

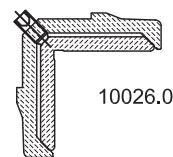

10026.00

Attrezzatura: PUNZONATRICE
Tooling: PUNCHING MACHINE

SQUADRETTE A CIANFRINARE
CORNER JOINTS TO BE CRIMPED

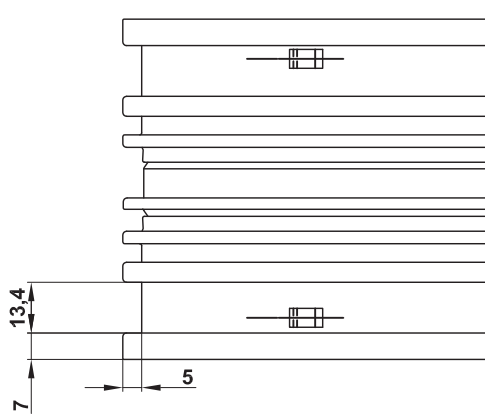

1F27001 / 1F27010 / 1F27011 / 1F27012 / 1F27014

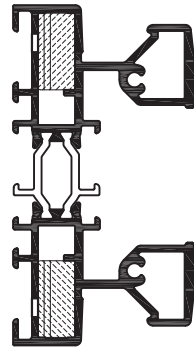

WIN 90s^{TT}
SYSTEM

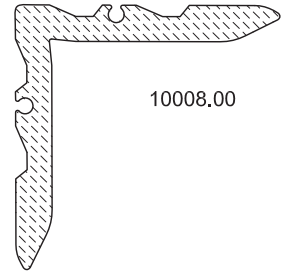

10008.00

Attrezzatura: CIANFRINATRICE
Tooling: CRIMPING MACHINE

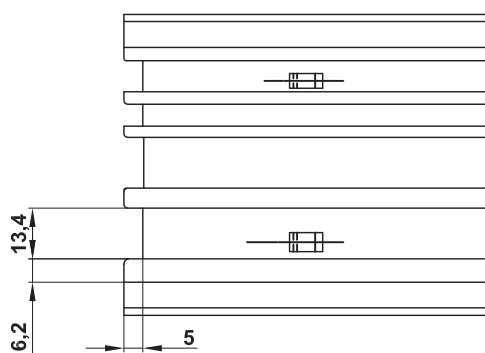

1F27008

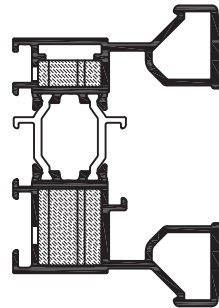

WIN 90s^{TT}
SYSTEM

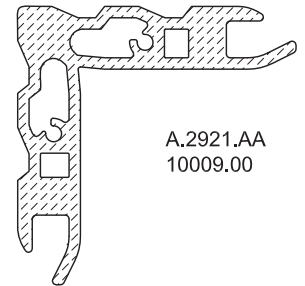

A.2921.AA
10009.00

Attrezzatura: CIANFRINATRICE
Tooling: CRIMPING MACHINE

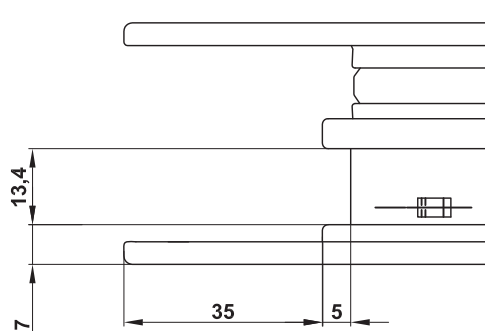

1F27003 / 1F27004 / 1F27009 / 1F270015

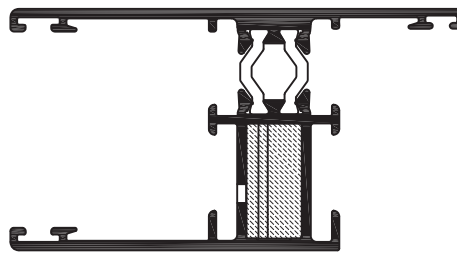

WIN 90s^{TT}
SYSTEM

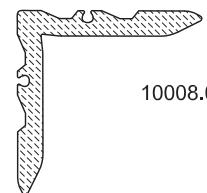

10008.00

Attrezzatura: CIANFRINATRICE
Tooling: CRIMPING MACHINE

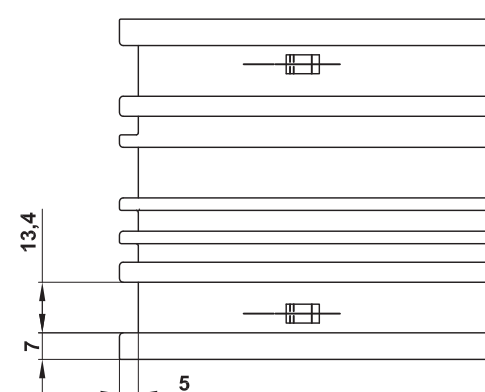

1F22001 / 1F22010

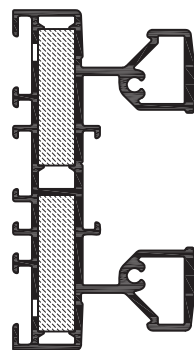

WIN 90s
SYSTEM

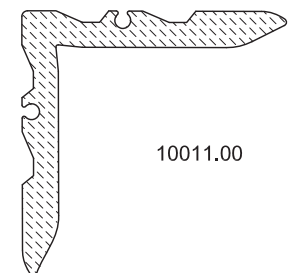

10011.00

Attrezzatura: CIANFRINATRICE
Tooling: CRIMPING MACHINE

SQUADRETTE A CIANFRINARE
CORNER JOINTS TO BE CRIMPED

WIN 90s
SYSTEM

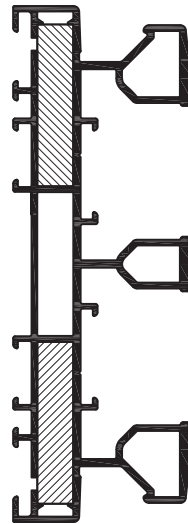
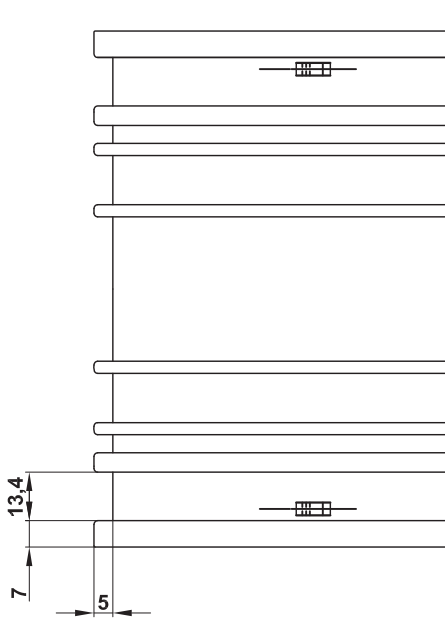

1F22002

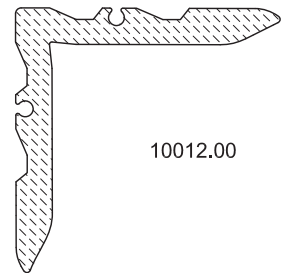

10012.00

Attrezzatura: CIANFRINATRICE
Tooling: CRIMPING MACHINE

WIN 90s
SYSTEM

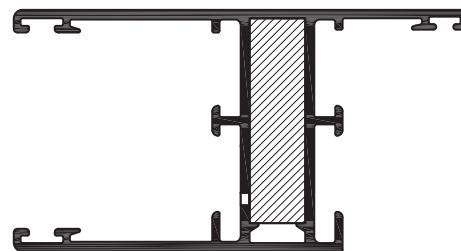
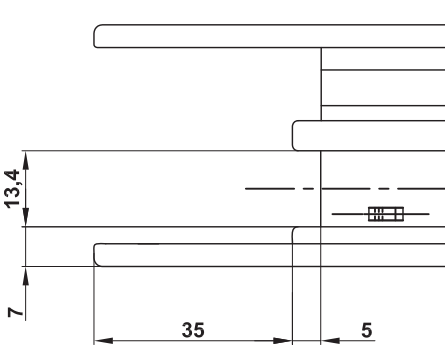

1F22003 / 1F22004 / 1F22012

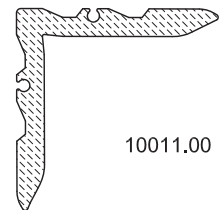

10011.00

Attrezzatura: CIANFRINATRICE
Tooling: CRIMPING MACHINE

REGOLO MOBILE
ADJUSTABLE FIXING

WIN 90s^{TT}
SYSTEM

WIN 90s
SYSTEM

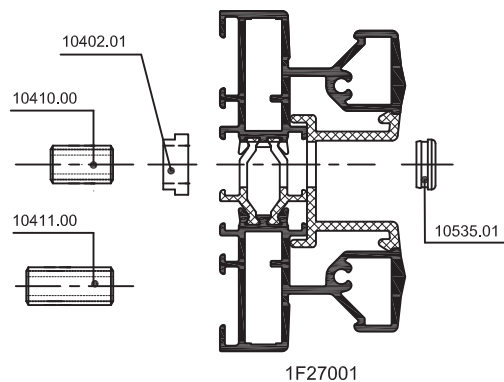
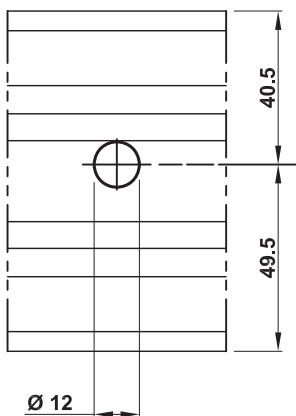

1F27001

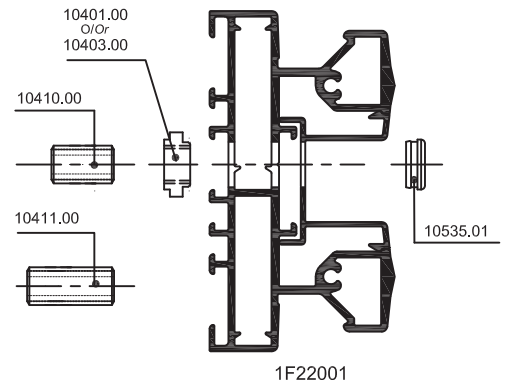

1F22001

Attrezzatura: TRAPANO
Tooling: DRILL

INTESTATURA TRAVERSI
TRANSOM BUTTING

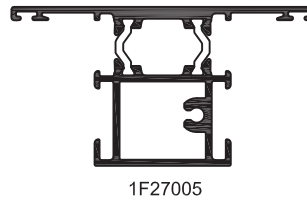
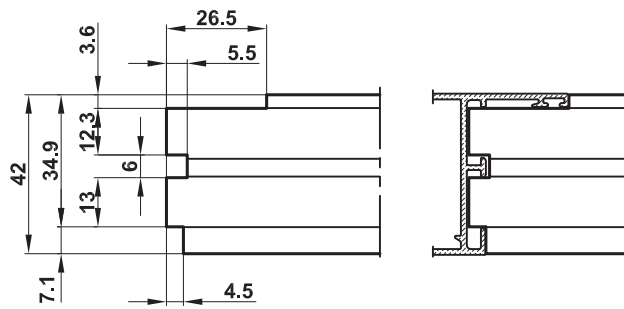

1F27005

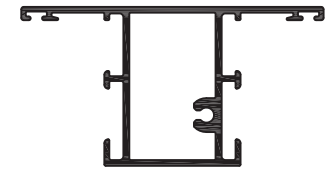

1F22005

WIN 90s^{TT}
SYSTEM

WIN 90s
SYSTEM

Attrezzatura: GRUPPO FRESE
Tooling: MILLING CUTTER GROUP

INTESTATURA TRAVERSI "1F27016"
TRANSOM BUTTING "1F27016"

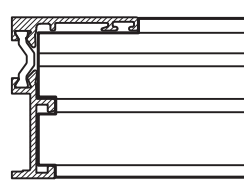
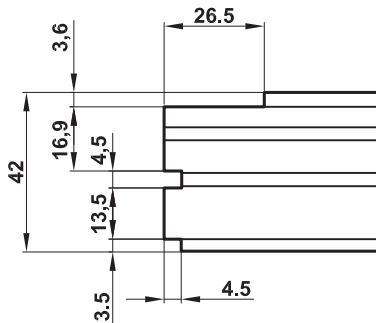

1F27015

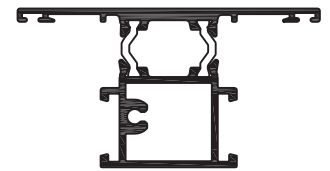

1F27016

WIN 90s^{TT}
SYSTEM

Attrezzatura: GRUPPO FRESE
Tooling: MILLING CUTTER GROUP

LAVORAZIONI PROFILATI 1F24002 - 1F24003
SECTION PROCESSING 1F24002 - 1F24003

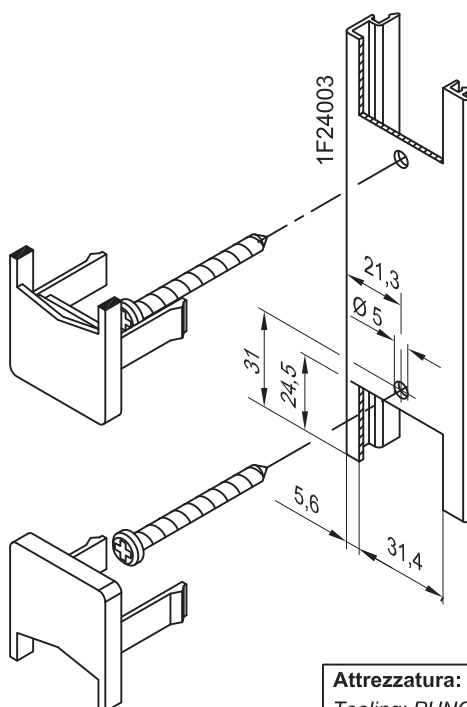

Attrezzatura: PUNZONATRICE
Tooling: PUNCHING MACHINE

Esempi applicativi
Examples applications

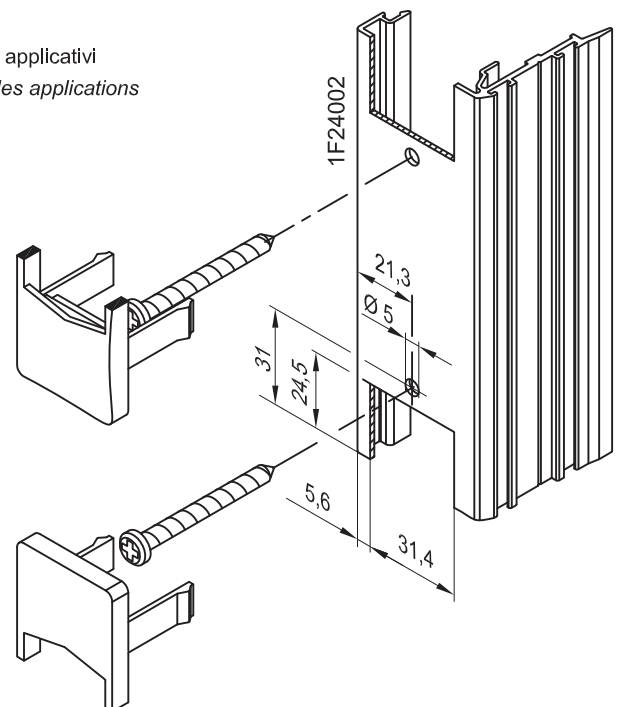

WIN 90s^{TT}
SYSTEM

WIN 90s
SYSTEM

LAVORAZIONI PROFILATO 1F22007 - 1F27007
SECTION PROCESSING 1F22007 - 1F27007

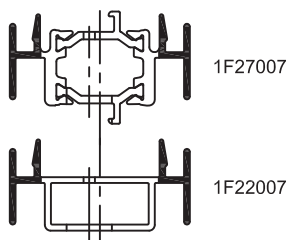
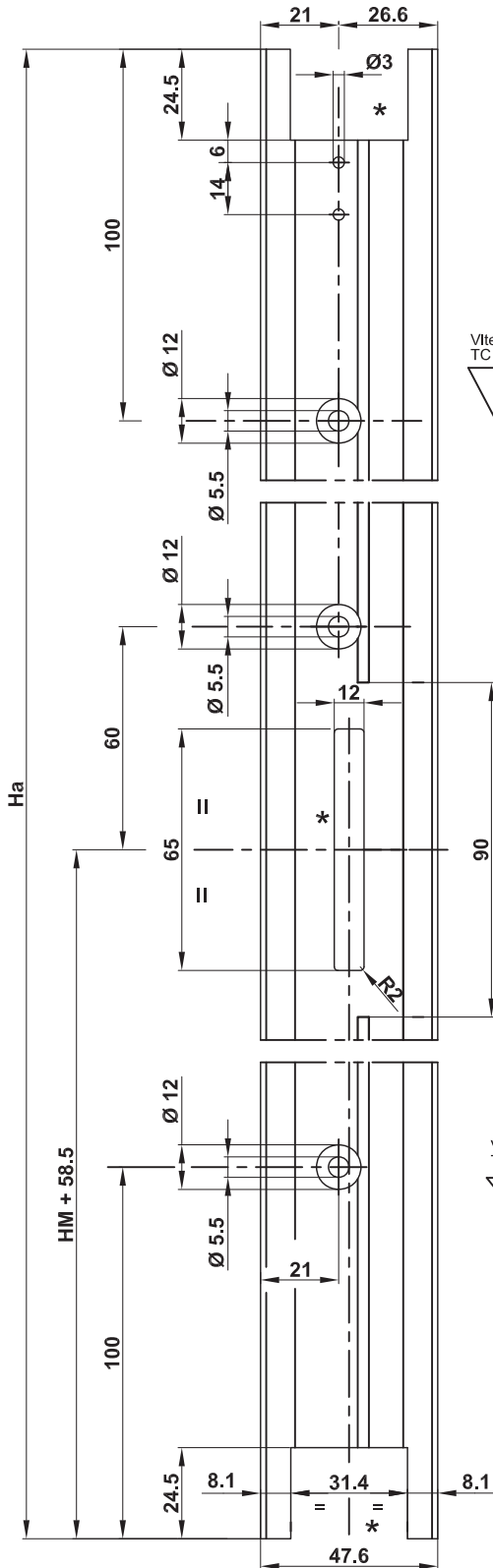

Esempi applicativi
Examples applications

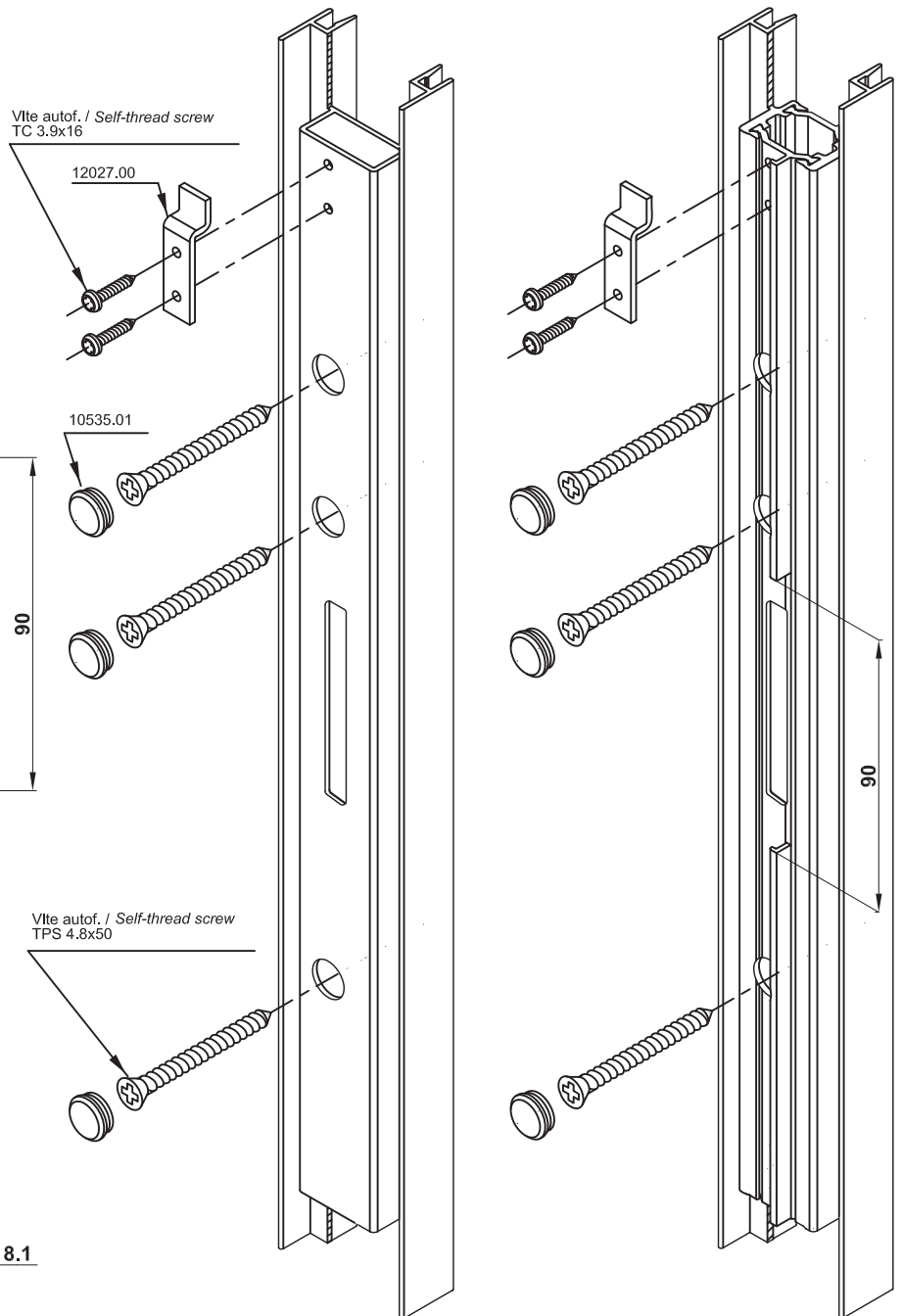

* **Attrezzatura: PANTOGRAFO**
Tooling: PANTOGRAPH

LAVORAZIONI E MONTAGGIO CHIUSURA AD INCASSO
PROCESSING AND MOUNTING EMBEDDED LOCK

Lavorazione profilato telaio
Processing frame section

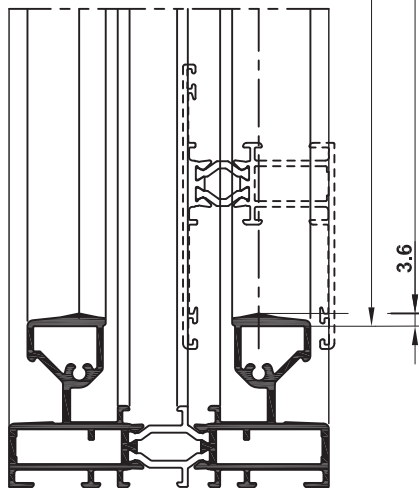
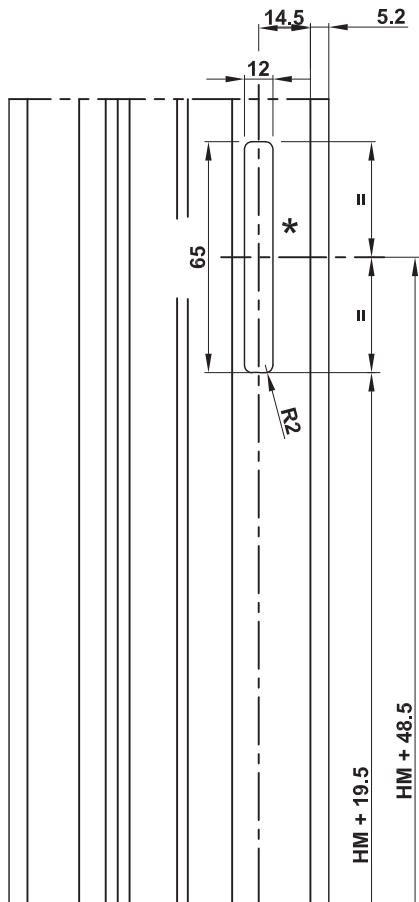

1F27001

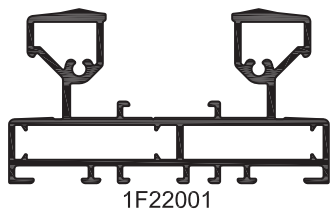

1F22001

* Attrezzatura: PANTOGRAFO
Tooling: PANTOGRAPH

Particolari di montaggio
riscontro laterale di
chiusura su telaio
Mounting details of lock side
striker plate on frame

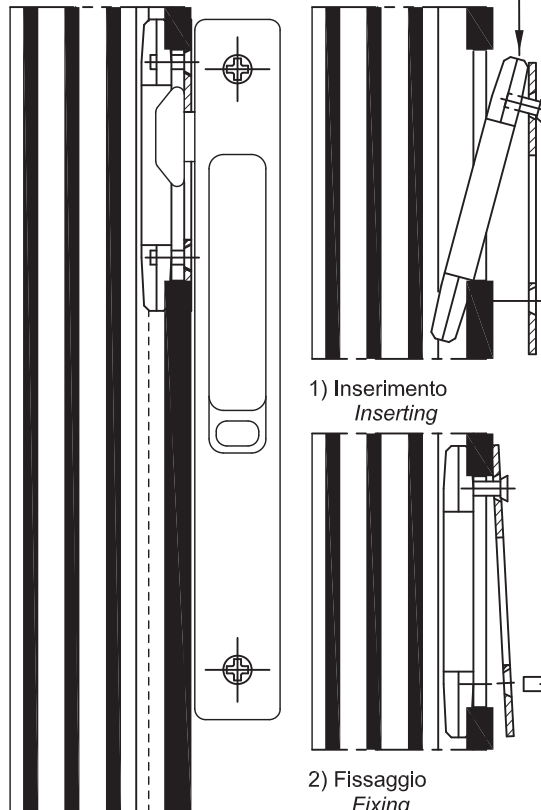

1) Inserimento
Inserting

2) Fissaggio
Fixing

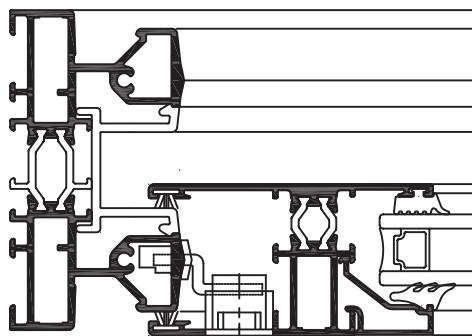
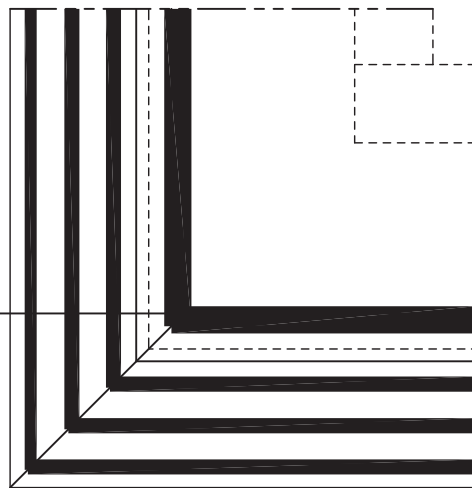

Filo anta
Wing limit

Lavorazione profilato anta
Processing wing section

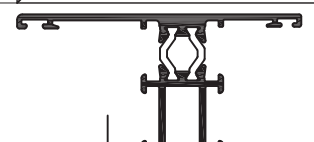
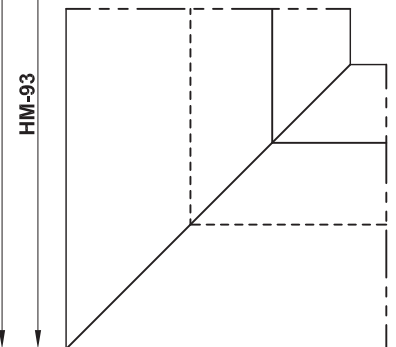
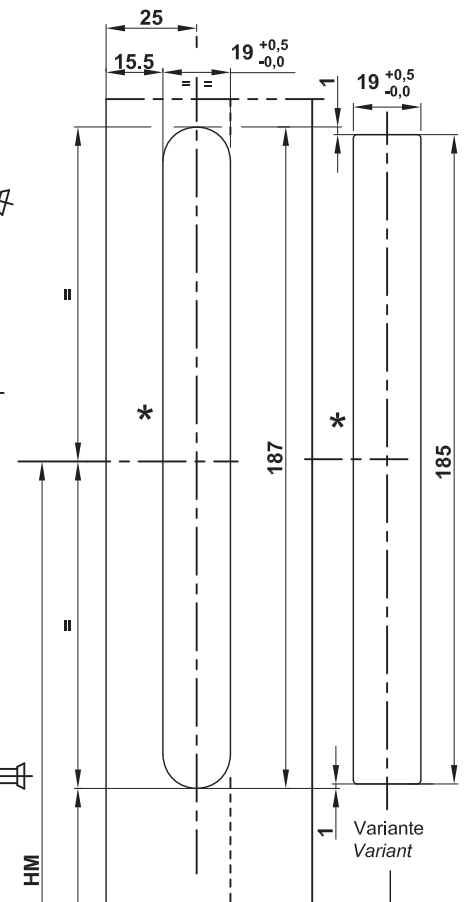

1F27003
1F27004
1F27009

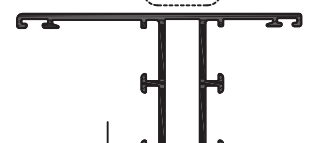

1F22003
1F22004
1F22012

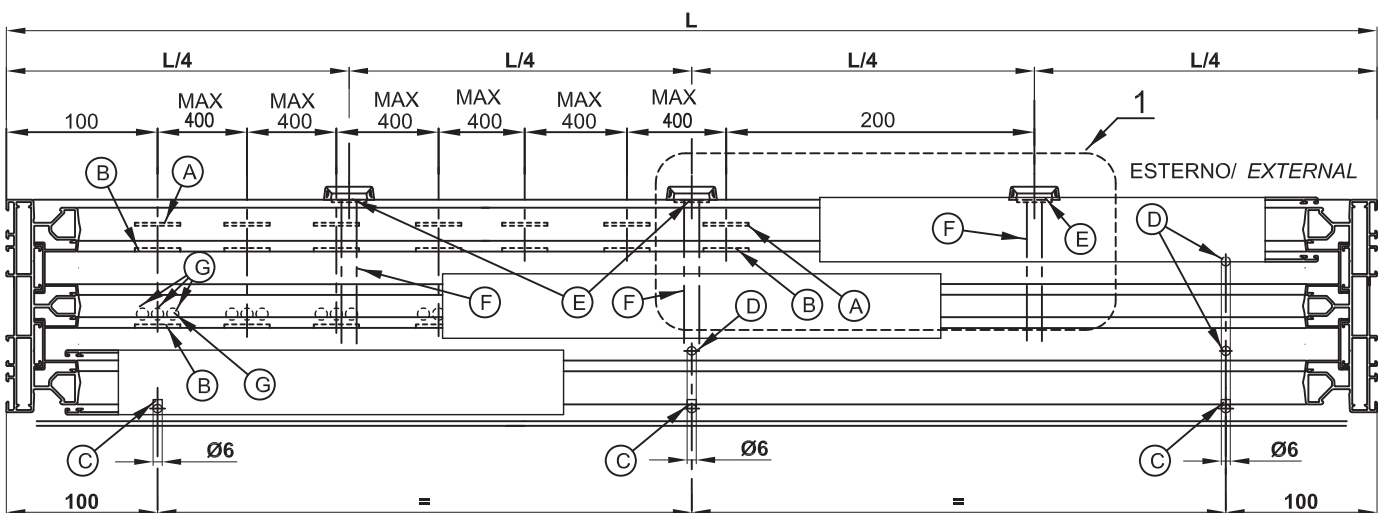
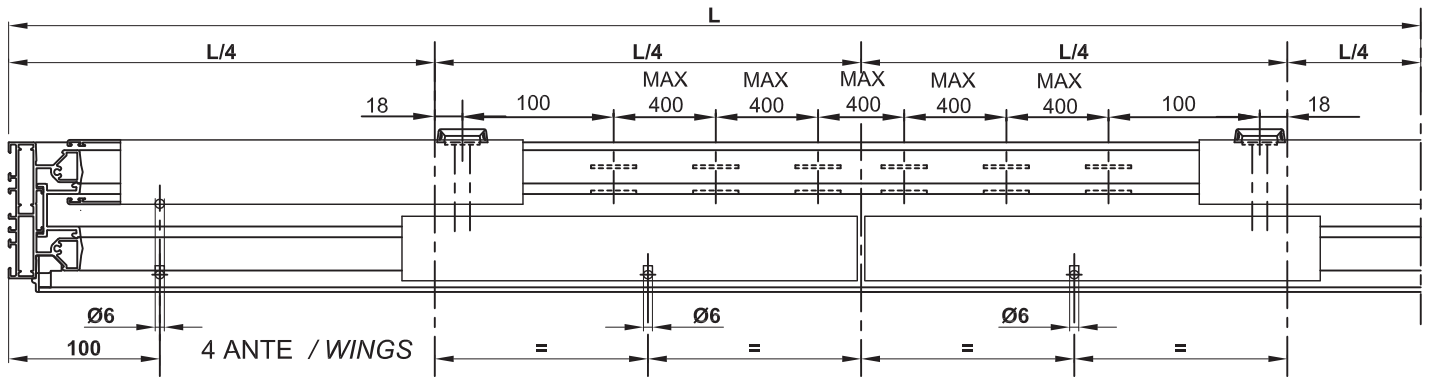
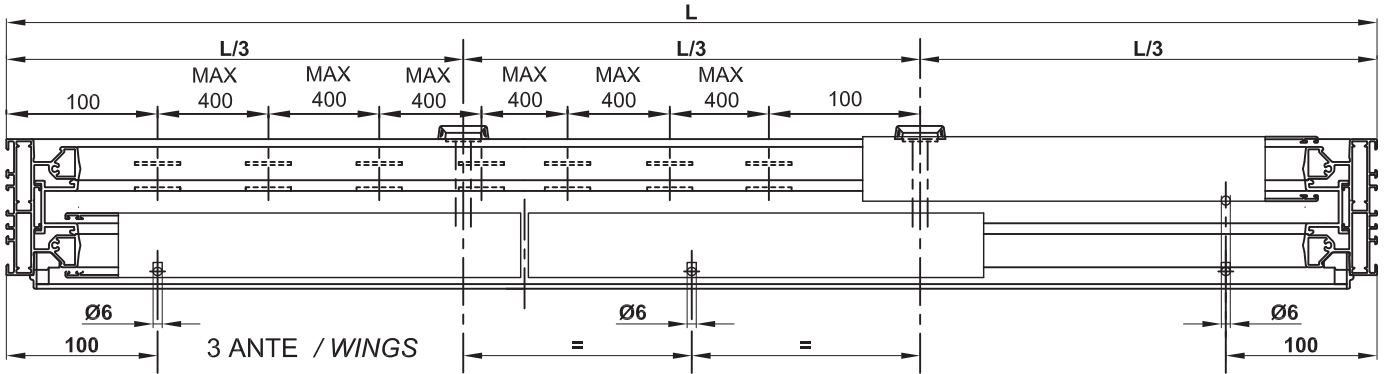
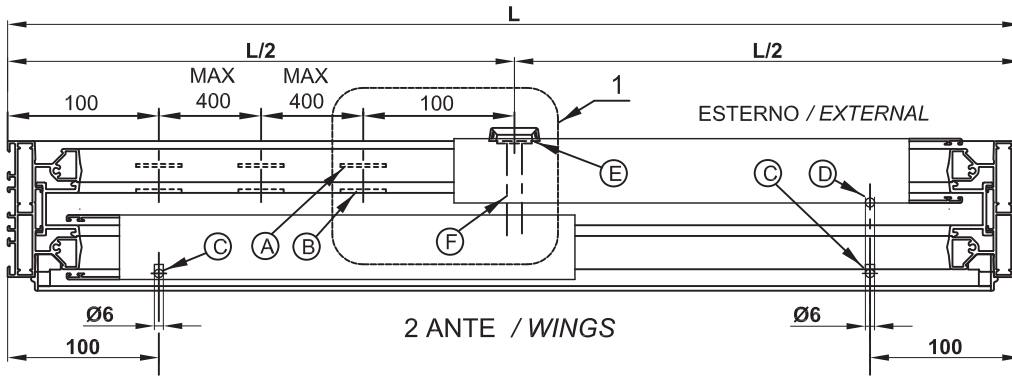

3 ANTE / WINGS

LAVORAZIONI: (A) → Attrezzatura: PUNZONATRICE
PROCESSING: Tooling: PUNCHING MACHINE

LAVORAZIONI: (D) (C) (F) (G) → Attrezzatura: TRAPANO
PROCESSING: Tooling: DRILL

LAVORAZIONI: (B) → Attrezzatura: PUNZONATRICE
PROCESSING: Tooling: PUNCHING MACHINE

LAVORAZIONI: (E) → Attrezzatura: PANTOGRAFO
PROCESSING: Tooling: PANTOGRAPH

LAVORAZIONI: PROCESSING:	(A)	Attrezzatura: PUNZONATRICE Tooling: PUNCHING MACHINE
LAVORAZIONI: PROCESSING:	(B)	Attrezzatura: PUNZONATRICE Tooling: PUNCHING MACHINE
LAVORAZIONI: PROCESSING:	(D) (C) (F)	Attrezzatura: TRAPANO Tooling: DRILL
LAVORAZIONI: PROCESSING:	(E)	Attrezzatura: PANTOGRAFO Tooling: PANTOGRAPH

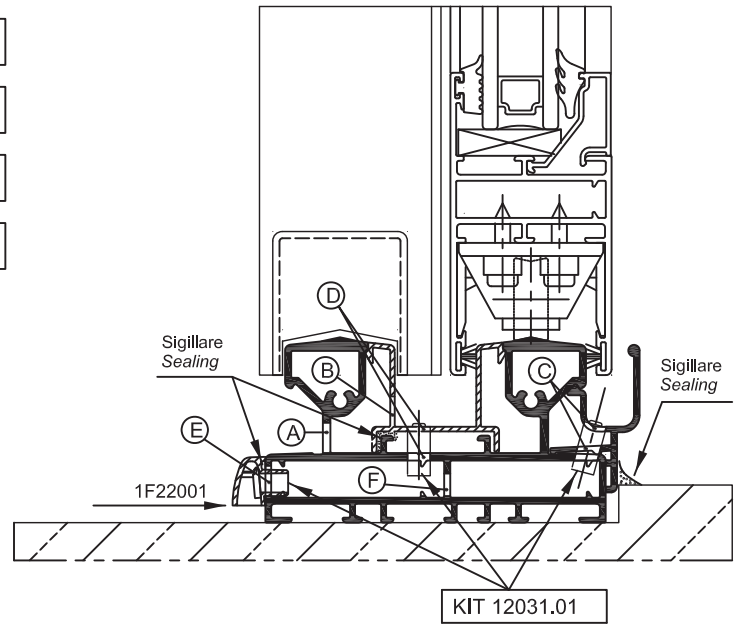
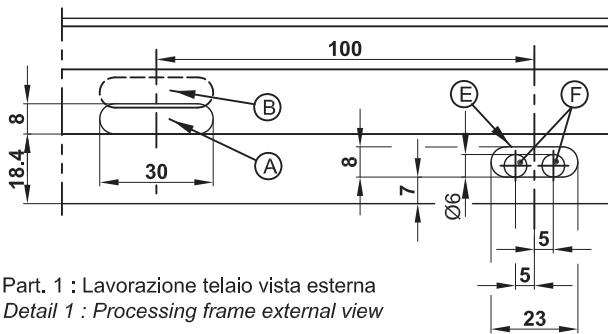

LAVORAZIONI: PROCESSING:	(A)	Attrezzatura: PUNZONATRICE Tooling: PUNCHING MACHINE
LAVORAZIONI: PROCESSING:	(B)	Attrezzatura: PUNZONATRICE Tooling: PUNCHING MACHINE
LAVORAZIONI: PROCESSING:	(D) (C) (F) (G)	Attrezzatura: TRAPANO Tooling: DRILL
LAVORAZIONI: TOOLINGS:	(E)	Attrezzatura: PANTOGRAFO Tooling: PANTOGRAPH

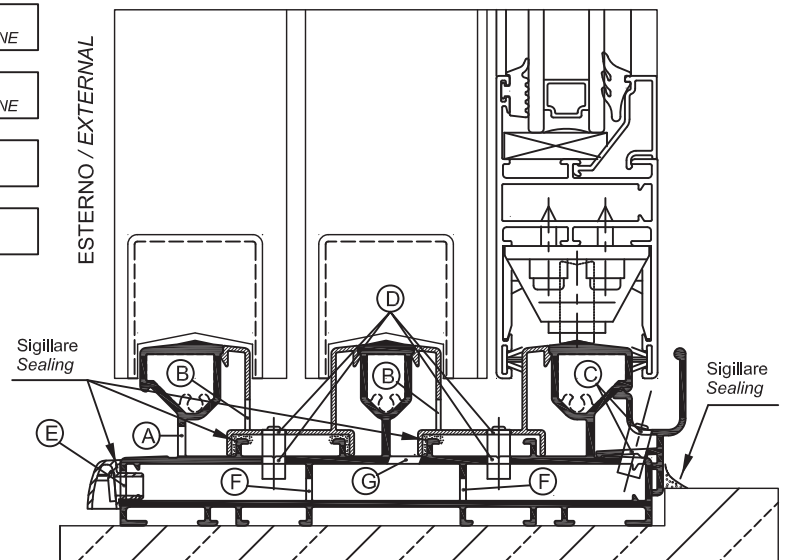
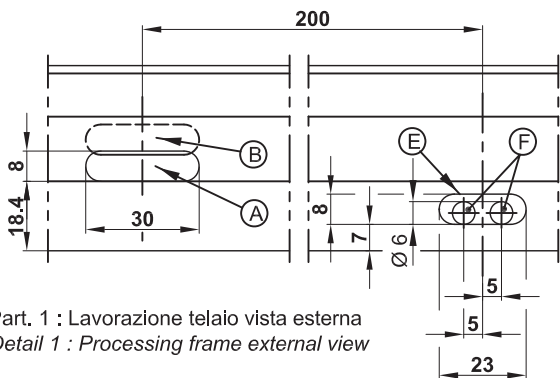

Raccomandiamo di prestare la **MASSIMA** attenzione alle sigillature del telaio di seguito elencate (già indicate a pag. F1-90s-A.03) per una buona tenuta all'acqua del serramento:

- interno tubolarità, perimetro taglio a 45° e fori tiraggio squadrette telaio 1F22001-2
- nel punto di contatto dei profilati 1F22001-2 e G.0301.QN su tutta la larghezza del telaio inferiore

We recommend to pay **MAXIMUM** attention to the here below listed sealing on the frame (as indicated at page F1-90s-A.03) to guarantee a good water tightness of the window:

- internal tubularity, 45° cut perimeter and corner joints holes on wing 1F22001-2
- at the contact point between the profiles 1F22001-2 and G.0301.QN on the whole length of the lower frame

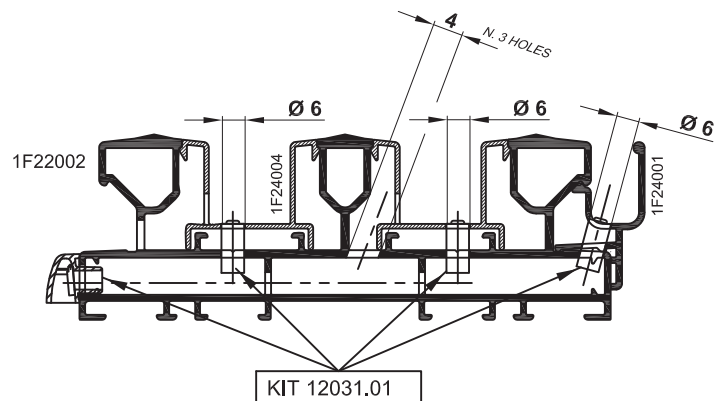

- LAVORAZIONI: PROCESSING: (A) → Attrezzatura: PUNZONATRICE Tooling: PUNCHING MACHINE
- LAVORAZIONI: PROCESSING: (B) → Attrezzatura: PUNZONATRICE Tooling: PUNCHING MACHINE
- LAVORAZIONI: PROCESSING: (D) (C) (F) → Attrezzatura: TRAPANO Tooling: DRILL
- LAVORAZIONI: PROCESSING: (E) → Attrezzatura: PANTOGRAFO Tooling: PANTOGRAPH

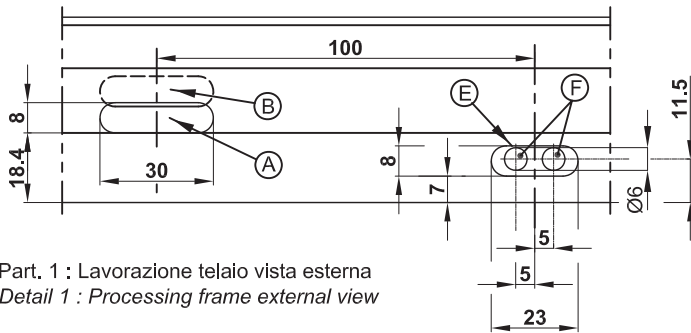

Part. 1 : Lavorazione telaio vista esterna
Detail 1 : Processing frame external view

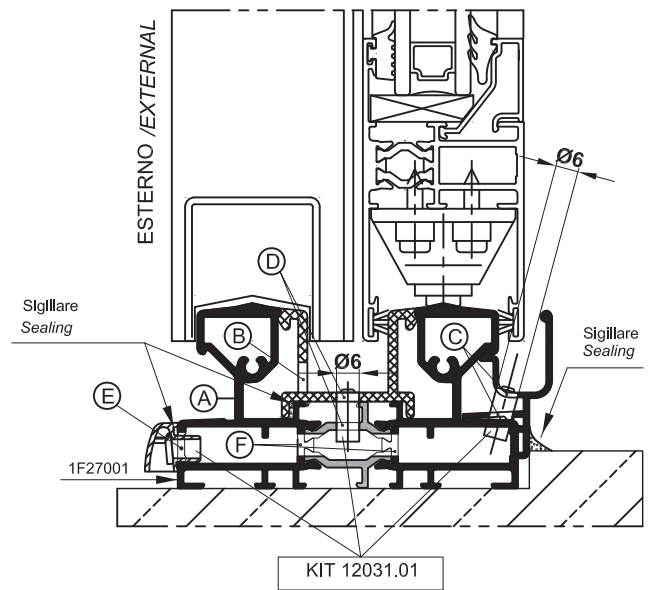

- LAVORAZIONI: PROCESSING: (A) → Attrezzatura: PUNZONATRICE Tooling: PUNCHING MACHINE
- LAVORAZIONI: PROCESSING: (B) → Attrezzatura: PUNZONATRICE Tooling: PUNCHING MACHINE
- LAVORAZIONI: PROCESSING: (D) (C) (F) (G) → Attrezzatura: TRAPANO Tooling: DRILL
- LAVORAZIONI: PROCESSING: (E) → Attrezzatura: PANTOGRAFO Tooling: PANTOGRAPH

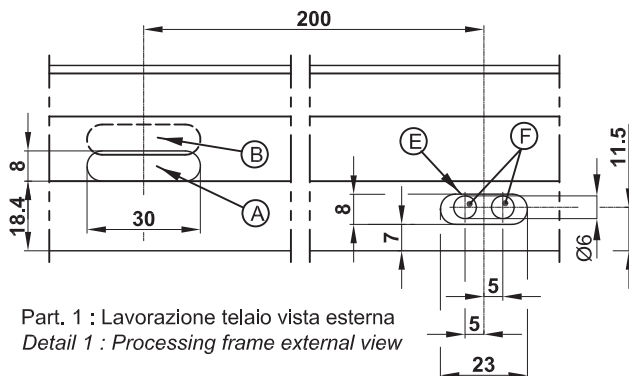

Part. 1 : Lavorazione telaio vista esterna
Detail 1 : Processing frame external view

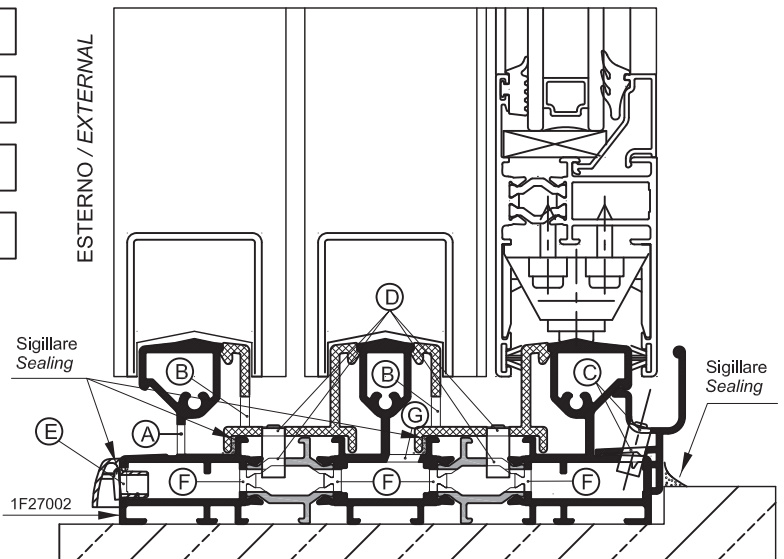

Raccomandiamo di prestare la **MASSIMA** attenzione alle sigillature del telaio di seguito elencate (già indicate a pag. F1-90s-A.03) per una buona tenuta all'acqua del serramento:

- interno tubolarità, perimetro taglio a 45° e fori tiraggio squadrette telaio 1F27001-2
 - nel punto di contatto dei profilati 1F27001-2 e G.0301.QN su tutta la lunghezza del telaio inferiore
- We recommend to pay **MAXIMUM** attention to the here below listed sealing on the frame (as indicated at page F1-90s-A.03) to guarantee a good water tightness of the window:
- internal tubularity, 45° cut perimeter and corner joints holes on wing 1F27001-2
 - at the contact point between the profiles 1F27001-2 and G.0301.QN on the whole length of the lower frame

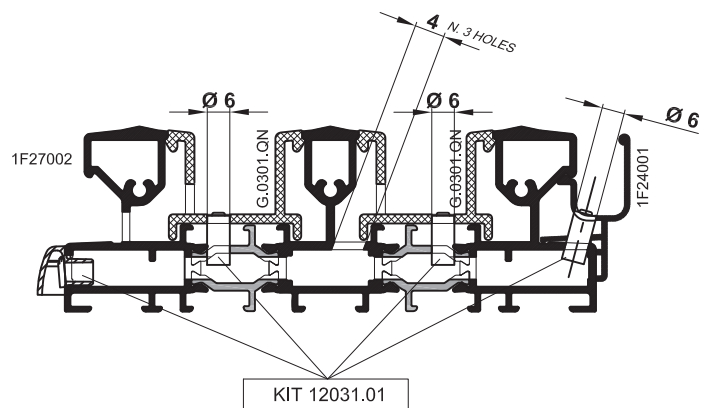

Inserimento a scatto su guida squadrette di allineamento
 Insertion by clipping on guide corner joint on fin of alignment

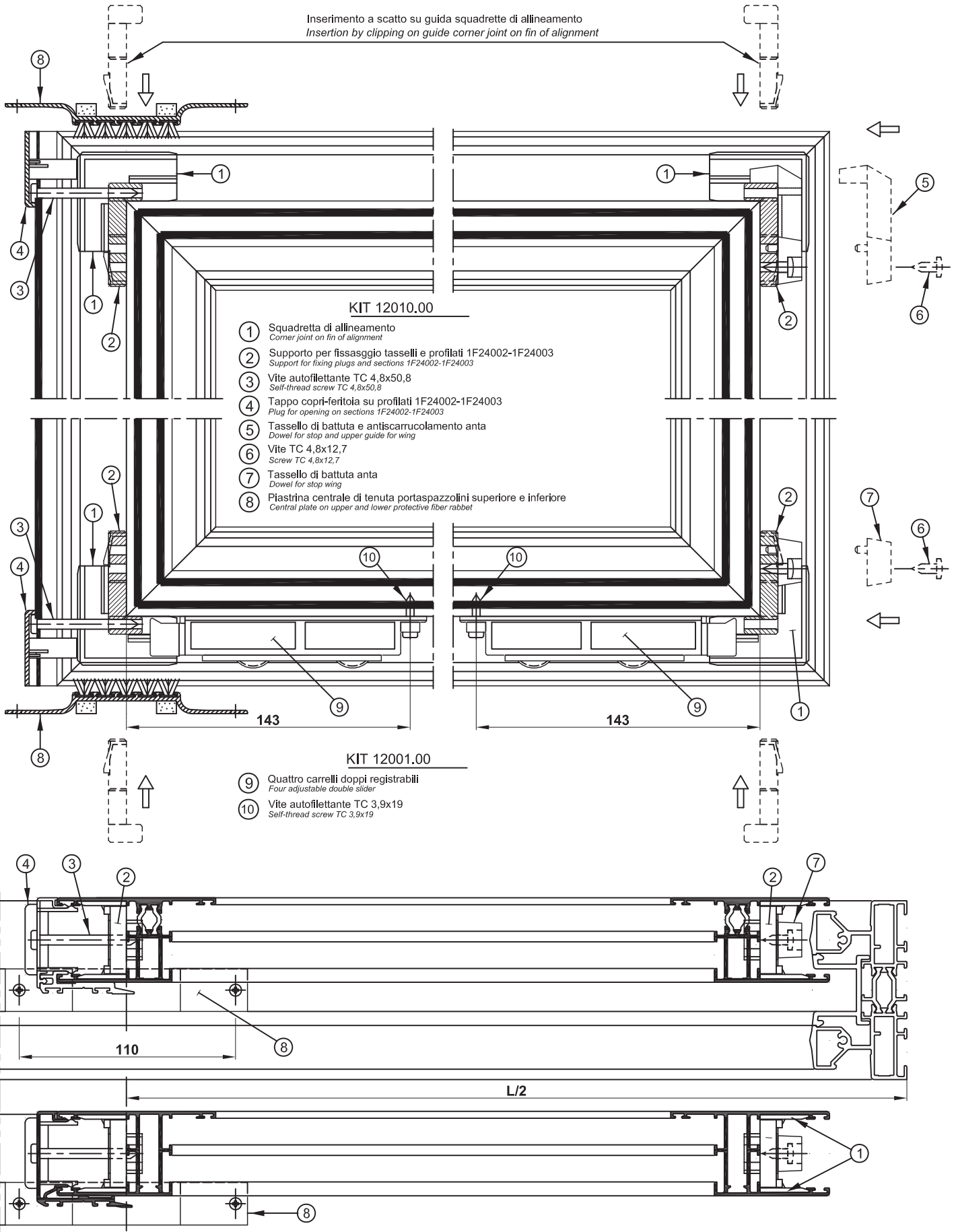

NEL CASO DI UTILIZZO SOLUZIONE "CHIUSURA MULTIPUNTO", ELIMINARE ACCESSORI N° 2 - 5 - 6 E 7
IF YOU MUST BE USED "MULTIPOINT LOCKED" SOLUTION, NOT TO BE USED ACCESSORIES N° 2 - 5 - 6 AND 7

A= DISTANZA PARTE INF.SCORREVOLE-ASSE MANIGLIA **B**= DISTANZA PARTE SUP.SCORREVOLE-ASSE MANIGLIA
TUTTE LE QUOTE E LE MISURE INDICATE SONO ESPRESSE IN mm

1 TAGLI ASTE DI COLLEGAMENTO

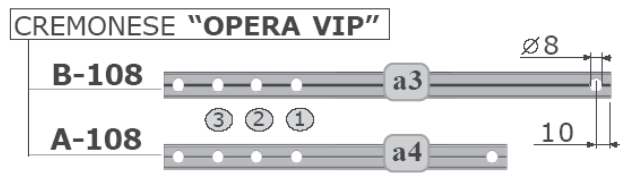
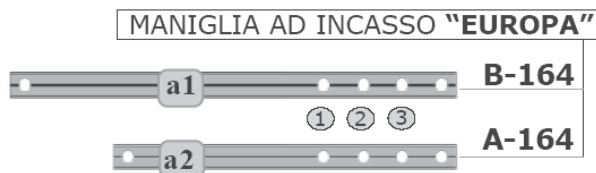

2 LAVORAZIONI SU SCORREVOLE PER INSERIMENTO MANIGLIA

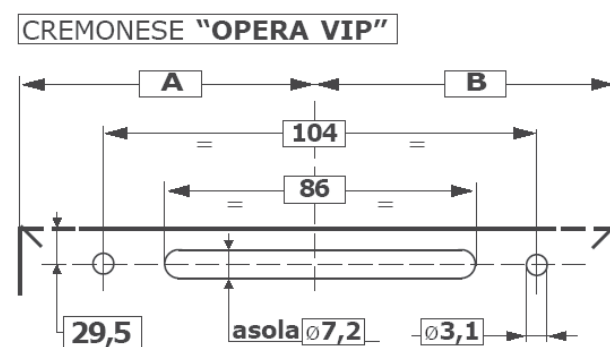
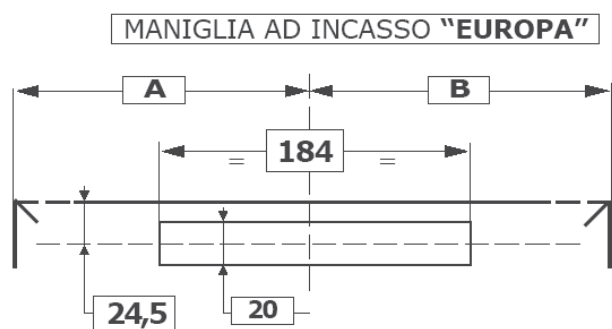

3 INSERIMENTO E FISSAGGIO COMPENSATORI (prima di assemblare l'anta)

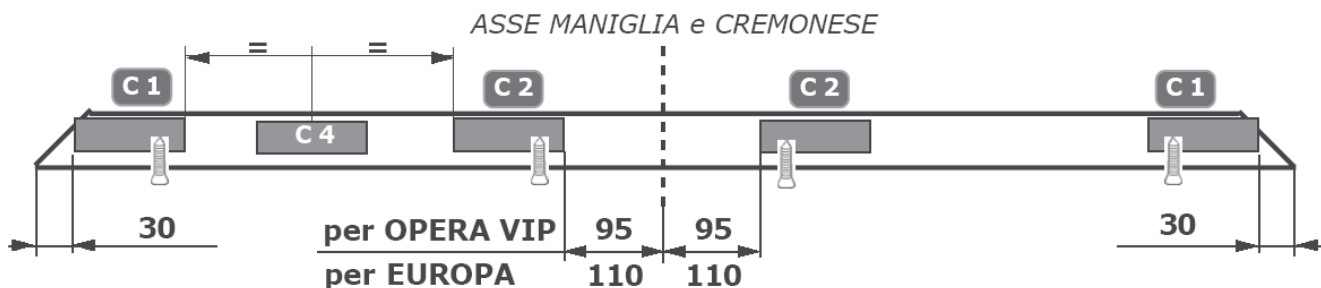

MANIGLIA AD INCASSO "EUROPA"

- 4** Fissare la maniglia EUROPA allo scorrevole.
- 5** Inserire le aste **a1** e **a2**, assemblando alle estremità, i puntali.
- 6** Fissare, con le viti (M6x14) e le staffe in dotazione, le aste alla maniglia.
- 7** Fissare la terza chiusura **C3** sull'asta **a1**, utilizzando i fori 2 e 3, vedi tagli aste. (E' possibile fissare la terza chiusura anche a infisso finito).
- 8** Ad anta ultimata e montata, regolare le "forchette" antiscarrucolamento. (vedi **C5**)

CREMONESE "OPERA VIP"

- 4** Fissare la cremonese OPERA VIP allo scorrevole, inserendo i blocchetti-giunzione.
- 5** Inserire le aste **a3** e **a4**, assemblando alle estremità i puntali.
- 6** Fissare, con i perni e i blocchetti in dotazione, le aste alla cremonese.
- 7** Fissare la terza chiusura **C3** sull'asta **a3**, utilizzando i fori 1 e 2, vedi tagli aste. (E' possibile fissare la terza chiusura anche a infisso finito).
- 8** Ad anta ultimata e montata, regolare le "forchette" antiscarrucolamento. (vedi **C5**)

PER IL MONTAGGIO DEGLI ACCESSORI NON INDICATI VEDI PAG. F9-90s-B.01
FOR ACCESSORY MOUNTING NOT INDICATED SEE PAG. F9-90s-B.01

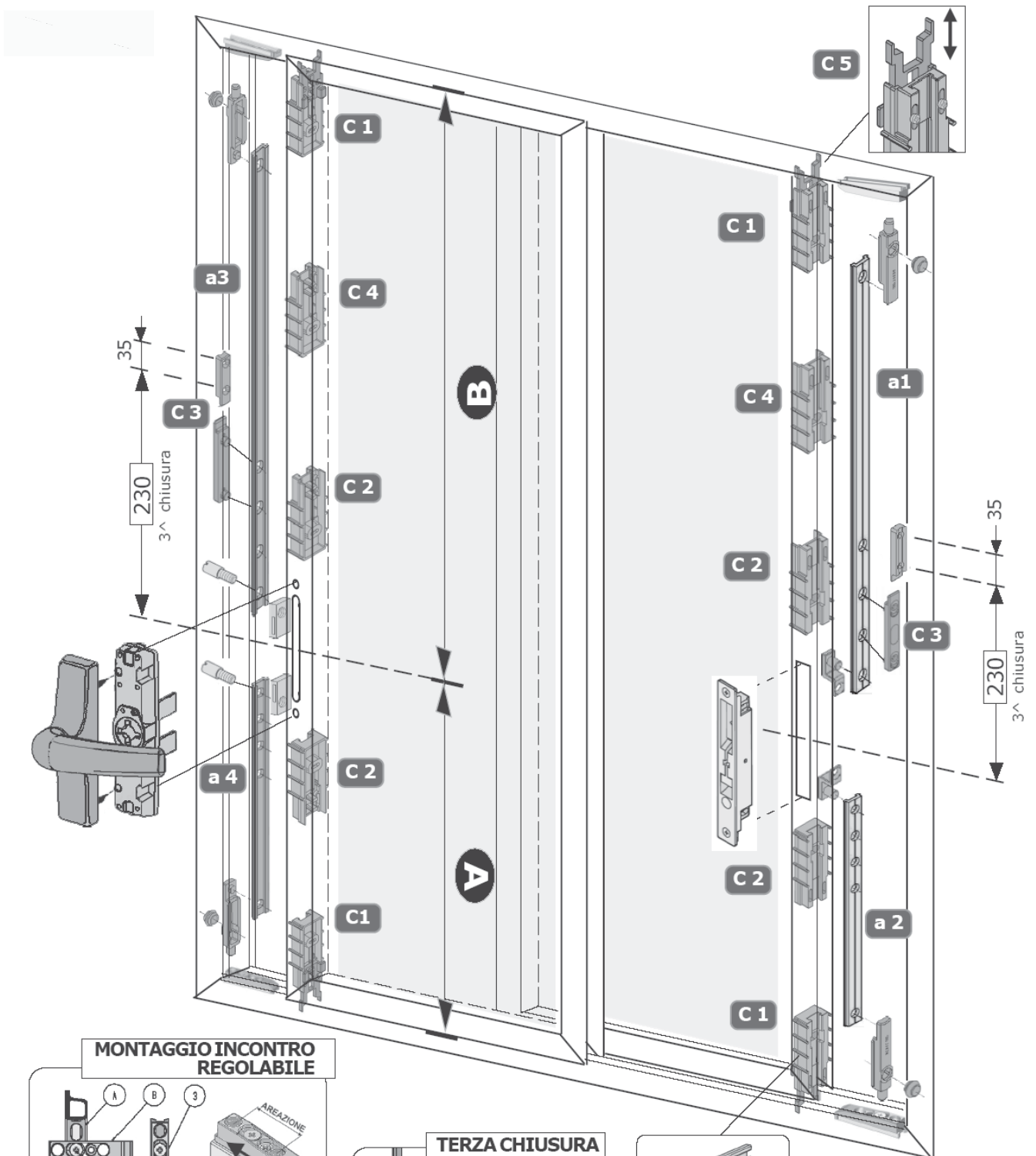

MONTAGGIO INCONTRO REGOLABILE

- 1) assemblare vite 2 con pezzi A-B
- 2) fissare con vite 1 il pezzo A al telaio
- 3) ruotare pezzo B senso freccia
- 4) regolare l'incontro B col puntale
- 5) bloccare vite 2
- 6) fissare vite 3

TERZA CHIUSURA

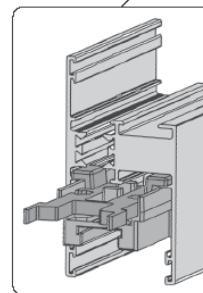

PER IL MONTAGGIO DEGLI ACCESSORI NON INDICATI VEDI PAG. F9-90s-B.01
FOR ACCESSORY MOUNTING NOT INDICATED SEE PAG. F9-90s-B.01

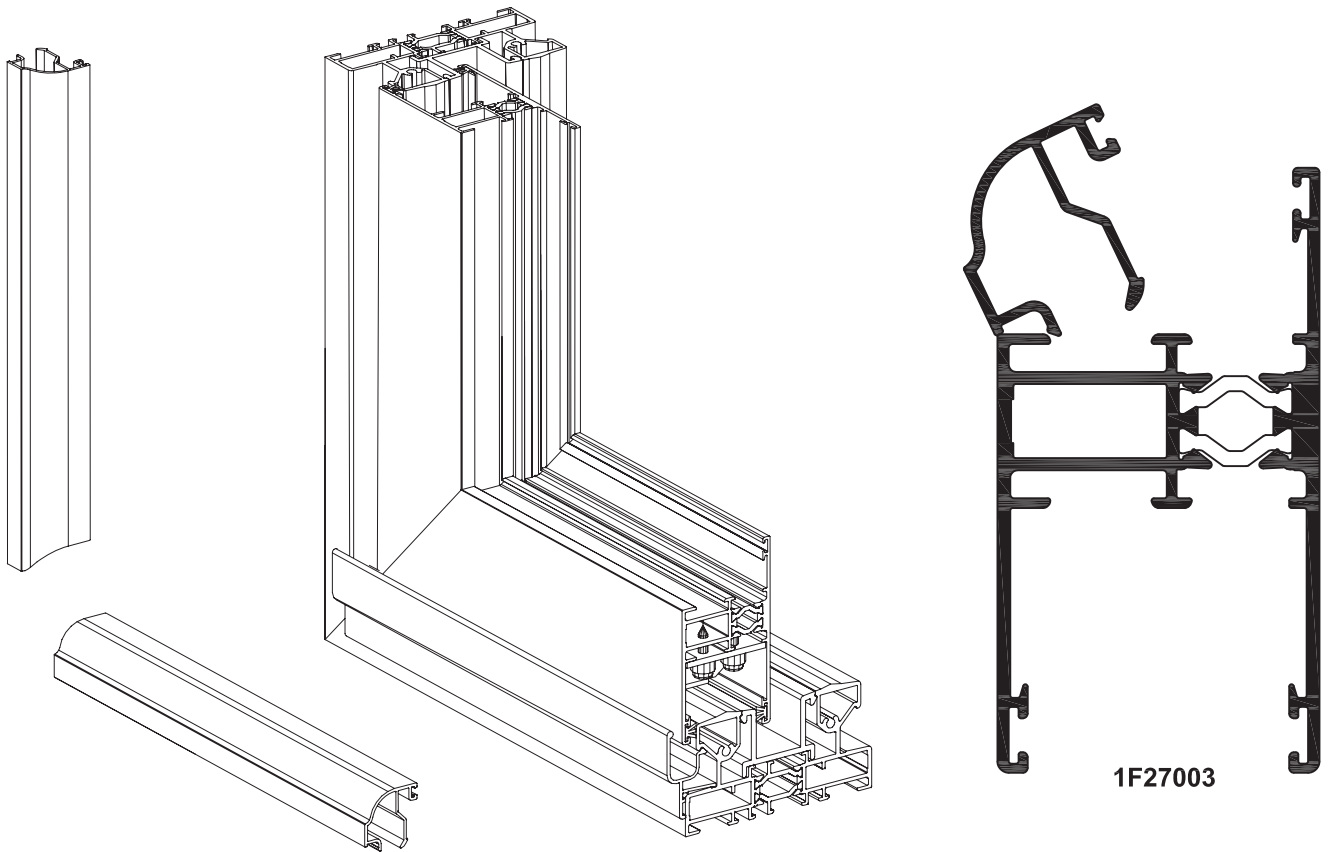

INTESTATURA FERMAVETRO "1F14072"
GLASS BEADING "1F14072" BUTTING

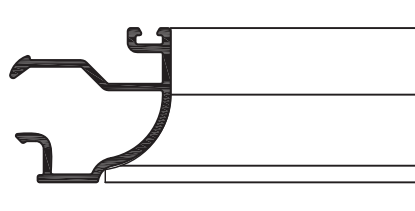
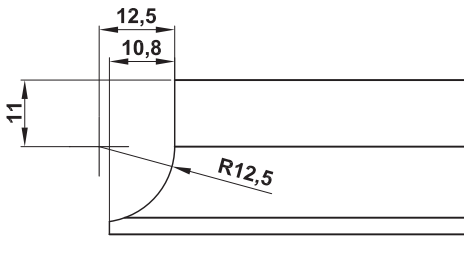

INTESTATURA FERMAVETRO "1F14073"
GLASS BEADING "1F14073" BUTTING

Attrezzatura: GRUPPO FRESE
 Tooling: MILLING CUTTER GROUP

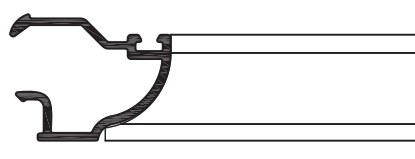
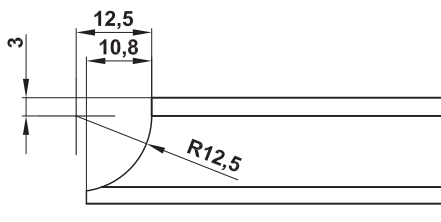

Attrezzatura: GRUPPO FRESE
 Tooling: MILLING CUTTER GROUP

APPLICAZIONE ANGOLO STAMPATO PER FERMAVETRI ARROTONDATI A SCATTO
MOULDED CORNER FOR SNAP-ON ROUNDED GLASS BEADING APPLICATION

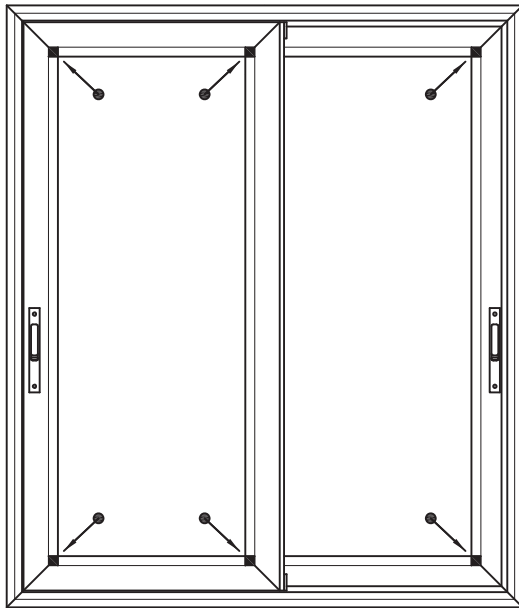

Angolo stampato per fermavetri arrotondati anta 1F27003
Moulded for snap-on rounded glass beading wing 1F27003

● ART.10545.XX



Angolo stampato per fermavetri arrotondati anta 1F27015
Moulded for snap-on rounded glass beading wing 1F27015

● ART. A.0202.BA

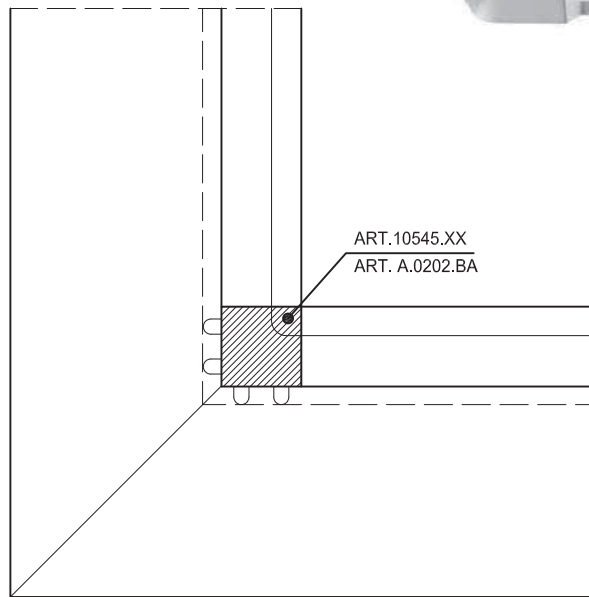
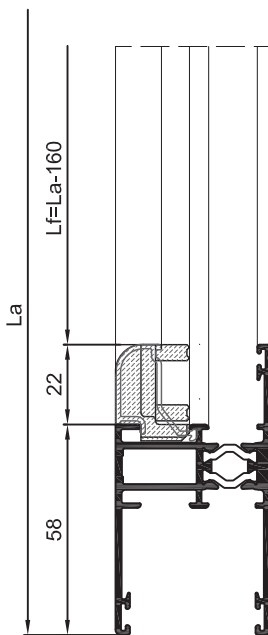

1F27003
1F27015

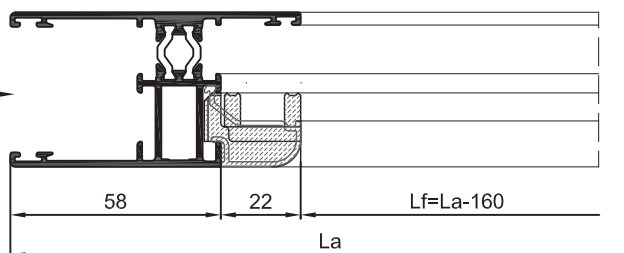

Sapa sviluppa, produce e commercializza in tutto il mondo profili a valore aggiunto. Sapa si avvale di oltre 13.000 dipendenti e centri di produzione in 30 paesi che collaborano per soddisfare tutte le esigenze dei clienti dei mercati più disparati.

Sapa Profili srl sviluppa, produce e commercializza profili per l'edilizia sempre innovativi. Original Systems garantisce una vasta e completa gamma di soluzioni residenziali e non, per rispettare le normative e per soddisfare le esigenze più complesse del mercato dell'involucro edilizio. I marchi di Original Systems, Sistema RTT, Sistema R, Teknowall, Teknowindow ed Alfil, sono distribuiti solo attraverso la rete Ufficiale di Distributori Sapa.

sapa: ... e scegli con serenità.

